



Operating the Wilson Company - Systems Division Filter Cart

- To operate the filter cart properly, insert the inlet hose into the drum or reservoir you want cleaned. The inlet hose is the hose located on the left as you face the cart. We recommend that you do not allow the wand to rest on the bottom of the drum or reservoir.
- Place the outlet hose and wand into the reservoir or drum containing the clean oil.
- Plug the filter cart into a 110 Volt grounded outlet.
- Turn the switch to the "ON" position. You will note that the indicator on the outlet filter moves. The filter indicator should move from the yellow (no element indication) to the green (cleaned element indication). This provides a positive indication that fluid is being transferred from the inlet to the outlet. Monitoring the filter indicator will ensure proper filtration.
- When the indicator gets to the *dirty element indication*, replace the element. For every two outlet elements that you replace, replace one inlet element.

Replacing the Filter Elements

To replace a filter element, follow this simple procedure:

- 1) Unplug the filter cart.
- 2) Loosen the hex head cap on cover. Turn slightly to clear cover screws and remove cover. Allow excess fluid to drain.
- 3) Remove diverter/bypass valve assembly from filter head. Filter element will follow valve assembly.
- 4) Remove element from diverter/bypass assembly. Replace the element.
- 5) Replace element on diverter/bypass valve assembly and install in filter housing. Make sure that the diverter O-ring seats properly into the head.
- 6) Check to make sure the notch on the diverter/bypass valve assembly lines up with the notch in the head.
- 7) Inspect the cover O-ring and replace it if necessary.
- 8) Replace cover and tighten hex head cap screws until they are snug. Do not over-tighten these screws.

The pump motor set does not require maintenance or service.

If you have any questions on the operation, maintenance, or care of your Filter Cart, please call:

Wilson Company - Systems Division

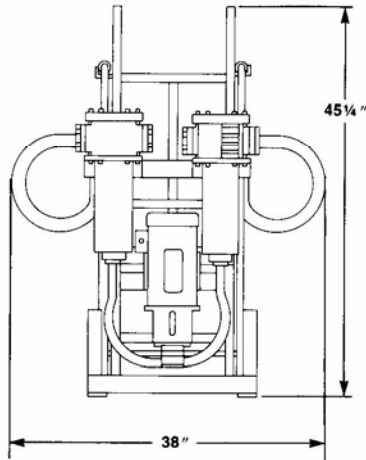

Portable Filter Cart – Model PFC-10

The PFC-10 is a heavy duty portable filter cart. Wilson designed it for use when adding or transferring hydraulic fluid to a system reservoir. The unit also conditions fluids already in a system. It saves oil and can remove free water. A 3/4 HP 1800 RPM motor produces up to a 10 GPM flow rate.

Special Features designed into the Wilson Portable Filter Cart include a heavy duty 2 wheel hand cart with a 400 pound on frame rating. The cart has 10" x 2" ball bearing wheels mounted on a heavy duty 5/8" axle. The PFC-10 has clear wire reenforced hoses that allow the user to see the fluid flow. It achieves extra quiet operation by using rubber vibration isolating motor mounts.

Wilson provides a variety of options for almost any filter cart requirement.

Specifications:

Weight: 160 pounds

Electrical Service Required: 115 volts, single phase, 60 cycles

Power Required: 10 amps

Maximum Recommended Fluid Viscosity: 2000 SUS (.85 specific gravity)

Filter Bypass Valve Settings: Inlet 3 psid (.2 bar) Outlet 25 psid (1.7 bar)

Outlet Filters: Visual Indicator on Outlet Filters

HOW TO ORDER

To determine product part number, make selections from the categories below:

PFC-10	SEALS	INLET FILTER	OUTLET FILTER	OPTIONS
EXAMPLE: PFC-10-BN-40SA-10C-O <i>(The above part number is the standard Wilson cart)</i>				
SEALS				
BN — Buna N (Nitrile) (Standard)				
F3 — Viton				
INLET FILTER				
40SA — Synthetic (Standard)				
40W — Stainless Steel Mesh				
74W — Stainless Steel Mesh				
20C — Cellulose				
OUTLET FILTER				
10C — Cellulose (BETA 10μ=5) (Standard)				
03C — Cellulose (BETA 3μ=6)				
20Q — Microglass II 75/12.5/17 Micron				
10Q — Microglass II <2/6/9 Micron				
05Q — Microglass II <2/<2/3.3 Micron				
02Q — Microglass II <2/<2/2 Micron				
WR — PAR-GEL™ Water Removal				
OPTIONS				
0 — None (Standard)				
6 — 20 Ft. Electrical Cord (Retractable Reel)				
9 — Visual Indicator on Inlet Filters				

Replacement Element Part Numbers

MEDIA CODE	BUNA SEALS	VITON SEALS
74W	924456	925043
40W	924455	925042
40SA	924448	925035
20C	924451	925038
10C	924450	925037
03C	924449	925036
20Q	933742 Q	933743 Q
10Q	924453 Q	925040 Q
05Q	924453 Q	925039 Q
02Q	933068 Q	933069 Q
WR	927584	928908

Typical Fluid Requirements:

Fluid Cleanliness Required for Typical Hydraulic Components

Component	ISO Cleanliness Level
Servo Control Valves	16/14/11
Proportional Valves	17/15/12
Vane and Piston Pumps/Motors	18/16/13
Directional & Pressure Control Valves	18/16/13
Gear Pumps/Motors	19/17/14
Flow Control Valves, Cylinders	20/18/15
New fluid	20/18/15

PFC-10 Fluid Conditioning/Filtering Performance *

Reservoir Capacity Gallons	Required Operating Time In Hours	Projected Cleanliness Level ISO
50	0.5	20/18/15
50	1.0	17/15/12
50	2.5	16/14/11
100	1.5	18/16/13
100	2.5	17/15/12
100	4.0	16/14/11
200	2.5	19/17/14
200	3.5	18/16/13
200	5.0	17/15/12

* The results in the chart are based on the following assumption: 1. Initial contamination level is 500,000 particles greater than 10 micrometers per 100 ml of fluid. (10MF cart) 2. Inlet filter fitted with 40SA element, outlet with 10C element. 3. System ingress rate equal to 1 x 10⁶ particles greater than 10 micrometers entering the system per minute.

Call us today and let one of our Systems Specialists solve your hydraulic problems.



16301 Addison Road
Addison, Texas 75001
Phone (972) 931-8666
Fax (972) 248-1177 or 248-7472