

6 Series Tube Fittings

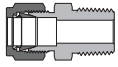

Contents

Male Connectors - CM



A-13

Bulkhead Male Connectors - BCM

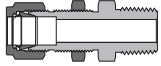

A-24

Thermocouple Connectors - TCM

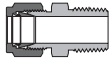

A-25

Chromatograph Fittings - U

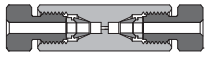

A-26

Chromatograph Fittings - TTT

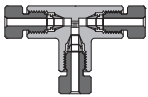

A-26

Column End Fittings - U

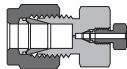

A-27

Female Connectors - CF

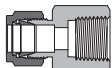

A-27

Bulkhead Female Connectors - BCF

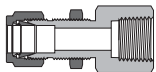

A-32

Unions - U

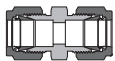

A-33

Conversion Unions - U

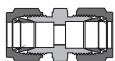

A-34

Reducing Unions - U

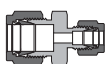

A-35

Bulkhead Unions - BU

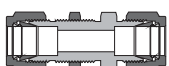

A-36

Bulkhead Reducing Unions - BU

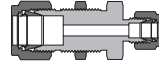

A-36

Bulkhead Conversion Unions - BU

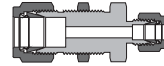

A-37

Bulkhead Locknuts - BN



A-37

Male Elbows - LM

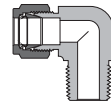

A-38

45° Male Elbows - VM

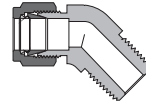

A-41

Adjustable Male Elbows - LP

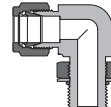

A-42

45° Adjustable Male Elbows - VP

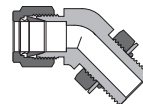

A-44

Female Elbows - LF

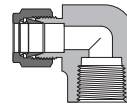

A-45

Union Elbows - LU

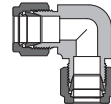

A-46

Union Reducing Elbows - LU

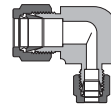

A-47

Bulkhead Union Elbows - BBLU

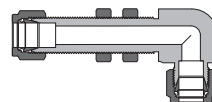

A-48

Contents

Male Branch Tees - TTM

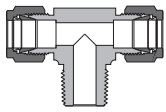

A-49

Male Run Tees - TMT

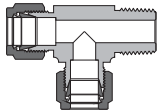

A-50

Adjustable Male Branch Tees - TTP

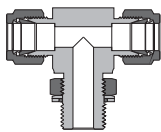

A-51

Adjustable Male Run Tees - TPT

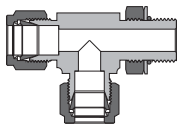

A-52

Female Branch Tees - TTF

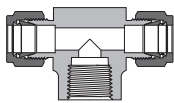

A-53

Female Run Tees - TFT

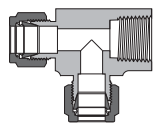

A-54

Union Tees - TTT

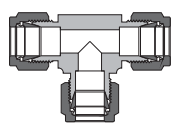

A-55

Reducing Union Tees - TTT

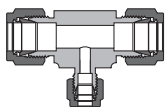

A-56

Union Crosses - C

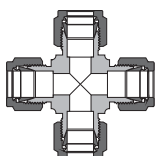

A-58

Caps - TC



A-58

Plugs - TP



A-59

Vent Protectors - VPF



A-59

Lapped Flange Connectors - LFC

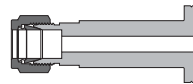

A-59

Nuts - N



A-60

Knurled Nuts



A-60

Male Nuts - MN



A-60

Front Ferrules - FF



A-61

Rear Ferrules - RF



A-61

Nuts + Ferrules - NFR



A-61

Nuts - Ferrule Sets - NFS



A-62

Ferrule Sets - FRS



A-62

Contents

Reducers - R

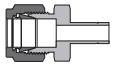

A-63

Bulkhead Reducers - BR

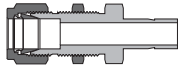

A-65

Reducer Elbows - LR

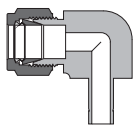

A-65

Insert for Soft Plastic Tubings - IN

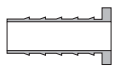

A-66

Port Connectors - P

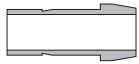

A-66

Reducing Port Connectors - P

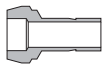

A-67

Sanitary Flange Fittings - SFF

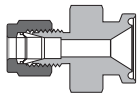

A-67

Male Adapters - AM

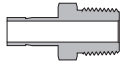

A-68

Female Adapters - AF

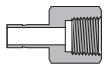

A-73

Weld Adapters - AW

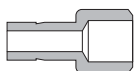

A-76

Flange Adapters - FA

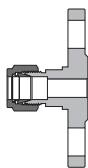

A-77

Weld Connectors - CW

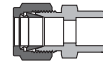

A-79

Weld Elbows - LW

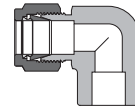

A-80

Automatic Tube Weld Connectors - CW

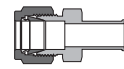

A-81

Calibration Fittings - FC

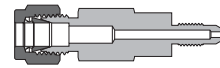

A-81

Dielectric Fittings - DF

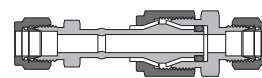

A-82

RS, RSD Gaskets - RS, RSD



A-83

RP Gaskets - RP



A-83

RG Gaskets - RG

A-84

RJ Gaskets - RJ

A-84

O-rings - VI, BN



A-85

Ordering Number Description

A-87

Features

- ⦿ Sizes range from 1/16" to 2" and 2 mm to 50 mm
- ⦿ Diverse materials and configurations are available
- ⦿ Precision machined components ensure perfect deformation of the ferrules and tubing
- ⦿ Hardened threads with smooth surface finish avoid galling and help to extend the fitting service life
- ⦿ Female nut threads are silver-plated to reduce the friction against the body threads
- ⦿ Radius junction design for elbows provides smooth flow path
- ⦿ Every fitting is marked with size, material and heat number
- ⦿ Fittings are easy to disconnect and retighten
- ⦿ 1/8" to 5/8", 3 mm to 16 mm fittings available with EC-79 certification

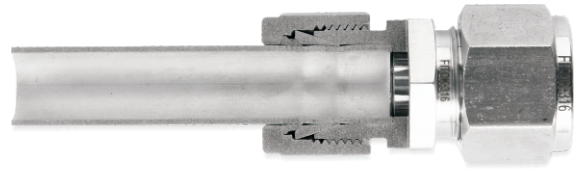

Technical Data

⦿ Thread Ends

NPT Threads (NPT)

- ⦿ Comply with ASME B1.20.1, SAE AS71051.

Thread Data						
Thread Size	Thread/in.	Dia. at Reference Plane (mm)			Handtight Engagement	
		Max. Dia.	Pitch Dia.	Min. Dia.	(mm)	Threads
1/16	27	7.894	7.142	6.389	4.064	4.32
1/8		10.242	9.489	8.737	4.102	4.36
1/4	18	13.616	12.487	11.358	5.785	4.10
3/8		17.055	15.926	14.797	6.096	4.32
1/2	14	21.224	19.772	18.321	8.128	4.48
3/4		26.569	25.117	23.666	8.618	4.75
1	11.5	33.228	31.461	29.694	10.160	4.60
1 1/4		41.985	40.218	38.451	10.668	4.83
1 1/2		48.054	46.287	44.520	10.668	4.83
2		60.092	58.325	56.558	11.065	5.01

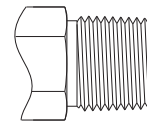

- 60° thread angle
- Pitch measured in inch
- Truncation of root and crest are parallel
- Taper 1:16
- Type of sealing: thread sealant

Working Pressures of NPT Thread Ends								
Thread Size	316 Stainless Steel and Carbon Steel				Brass			
	Male		Female		Male		Female	
	psig	bar	psig	bar	psig	bar	psig	bar
1/16	11000	757	6700	460	5500	378	3300	227
1/8	10000	690	6500	447	5000	344	3200	220
1/4	8000	551	6600	454	4000	275	3300	227
3/8	7800	537	5300	365	3900	268	2600	179
1/2	7700	530	4900	337	3800	261	2400	165
3/4	7300	502	4600	316	3600	248	2300	158
1	5300	365	4400	303	2600	179	2200	151
1 1/4	6000	410	5000	344	3000	200	2500	172
1 1/2	5000	344	4600	317	2500	172	2300	158
2	3900	268	3900	268	1900	130	1900	130

Working pressure is based on ANSI/ASME B31.3 at ambient temperature.

ISO Tapered Threads (R, R1, R2, RC, RT, PT, BSPT, ZG)

© Comply with ISO 7-1, EN 10226-1, BS 21, DIN 2999, JIS B0203.

Thread Data						
Thread Size	Thread/in.	Dia. at Reference Plane (mm)			Gauge Length	
		Max. Dia.	Pitch Dia.	Min. Dia.	(mm)	Threads
1/16	28	7.723	7.142	6.561	4.0	4.4
1/8		9.728	9.147	8.566	4.0	4.4
1/4	19	13.157	12.301	11.445	6.0	4.5
3/8		16.662	15.806	14.950	6.4	4.8
1/2	14	20.955	19.793	18.631	8.2	4.5
3/4		26.441	25.279	24.117	9.5	5.2
1	11	33.249	31.770	30.291	10.4	4.5
1 1/4		41.910	40.431	38.952	12.7	5.5
1 1/2		47.803	46.324	44.845	12.7	5.5
2		59.614	58.135	56.656	15.9	6.9

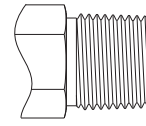

- 55° thread angle
- Pitch measured in inch
- Truncation of root and crest are round
- Taper 1:16
- Type of sealing: thread sealant

Working Pressures of ISO Tapered Thread Ends

The working pressures of ISO tapered thread ends are the same as that of the NPT thread ends.

ISO Parallel Threads (G, RP, PF, BSPP)

© Comply with ISO 228-1, DIN ISO 228-1, JIS B0202, BS 2779.

Thread Data				
Thread Size	Thread/in.	Basic Dia. (mm)		
		Max. Dia.	Pitch Dia.	Min. Dia.
1/16	28	7.723	7.142	6.561
1/8		9.728	9.147	8.566
1/4	19	13.157	12.301	11.445
3/8		16.662	15.806	14.950
1/2	14	20.955	19.793	18.631
5/8		22.911	21.749	20.587
3/4		26.441	25.279	24.117
7/8		30.201	29.039	27.877
1	11	33.249	31.770	30.291
1 1/8		37.897	36.418	34.939
1 1/4		41.910	40.431	38.952
1 1/2		47.803	46.324	44.845
1 3/4		53.746	52.267	50.788
2		59.614	58.135	56.656

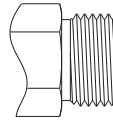

- 55° thread angle
- Pitch measured in inch
- Truncation of root and crest are round

Types of Sealing for ISO Parallel Threads

1. RS Stud End, RS Gasket and RP Port

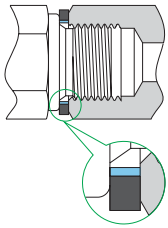

- RS stud end complies with DIN 3852-2 type A
- For RS gasket, see page A-83
- RP port complies with DIN 3852-2 type X

2. RP Stud End, RP Gasket and RP Port

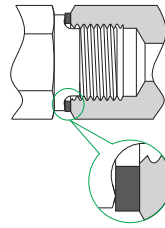

- RP stud end complies with DIN 3852-2 type B
- For RP gasket, see page A-83
- RP port complies with DIN 3852-2 type X

3. PP Stud End and RP Port

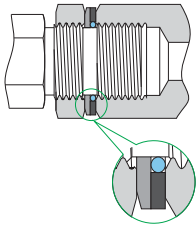

- PP Stud end complies with ISO 1179-3
- RP port complies with DIN 3852-2 type X

4. RG Port, RG Gasket and BP Stud End

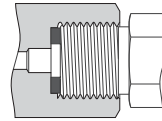

- RG port complies with EN 837-1/3
- For RG gasket, see page A-84

Working Pressures of Adjustable ISO Parallel Thread Ends (PP)

Thread Size	316 Stainless Steel and Carbon Steel	
	psig	bar
1/8	4568	315
1/4		
3/8		
1/2	2320	160
3/4		
1		

SAE/MS Straight Threads (UN, UNJ)

☉ Comply with ASME B1.1, ISO R725.

Thread Data

Thread Size	Thread/ in.	Basic Dia. (mm)		
		Max. Dia.	Pitch Dia.	Min. Dia.
5/16-24	24	7.938	7.249	6.792
3/8-24	24	9.525	8.837	8.380
7/16-20	20	11.113	10.287	9.738
1/2-20	20	12.700	11.875	11.326
9/16-18	18	14.288	13.325	12.761
3/4-16	16	19.050	18.019	17.330
7/8-14	14	22.225	21.046	20.262
1 1/16-12	12	26.988	25.613	24.719
1 3/16-12	12	30.163	28.788	27.871
1 5/16-12	12	33.338	31.963	31.046
1 5/8-12	12	41.275	39.901	38.984
1 7/8-12	12	47.625	46.251	45.324
2 1/2-12	12	63.500	62.126	61.209

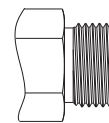

- 60° thread angle
- Pitch measured in inch
- Truncation of root and crest are parallel

Types of Sealing for SAE/MS Threads

1. ST Stud End and ISO 11926-1 Port

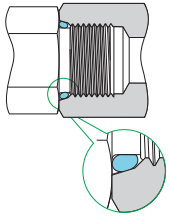

- ST stud end complies with ISO 11926-3
- For O-ring, see page A-85

2. 37° Flare (AN) Stud and Flared Tubing

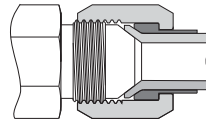

- The type of sealing complies with SAE J514

Working Pressures of SAE/MS Thread Ends

Thread Size	316 Stainless Steel and Carbon Steel			
	Non-adjustable		Adjustable	
	psig	bar	psig	bar
5/16-24	4568	315	4568	315
3/8-24				
7/16-20				
1/2-20			3626	250
9/16-18				
3/4-16	3626	250	2900	200
7/8-14				
1 1/16-12	2900	200	2320	160
1 3/16-12				
1 5/16-12				
1 5/8-12	2320	160	1813	125
1 7/8-12				
2 1/2-12	1813	125	1450	100

Working pressures are based on ISO 11926-3 at ambient temperature.

Metric Threads (M)

☉ Comply with ISO 261.

Thread Data

Thread Size	Pitch (mm)	Basic Dia. (mm)		
		Max. Dia.	Pitch Dia.	Min. Dia.
M6 x 1	1	6.000	5.350	4.917
M8 x 1		8.000	7.350	6.917
M10 x 1		10.000	9.350	8.917
M12 x 1.5	1.5	12.000	11.026	10.376
M14 x 1.5		14.000	13.026	12.376
M16 x 1.5		16.000	15.026	14.376
M18 x 1.5		18.000	17.026	16.376
M20 x 1.5		20.000	19.026	18.376
M22 x 1.5		22.000	21.026	20.376
M24 x 1.5		24.000	23.026	22.376
M27 x 2	2	27.000	25.701	24.835
M30 x 2		30.000	28.701	27.835
M33 x 2		33.000	31.701	30.835
M36 x 2		36.000	34.701	33.835
M39 x 2		39.000	37.701	36.835
M42 x 2		42.000	40.701	39.835
M45 x 2		45.000	43.701	42.835
M48 x 2		48.000	46.701	45.835

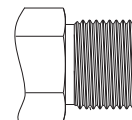

- 60° thread angle
- Pitch measured in mm
- Truncation of root and crest are parallel

Types of Sealing for Metric Threads

1. MRS Stud End, RS-M gasket and MS Port

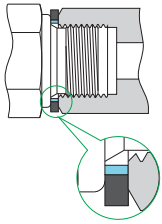

- MRS stud end complies with DIN 3852-1 type A
- For RS-M gasket, see page A-83

2. MS Stud End, RG-M gasket and MS Port

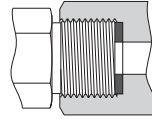

- For RG-M gasket, see page A-84

3. MST Stud End and ISO 6149-1 Port

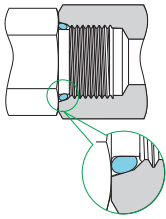

- MST stud end complies with ISO 6149-3
- For O-ring, see page A-85

Working Pressures for MST Stud Ends				
Thread Size	Stainless Steel and Carbon Steel			
	Non-adjustable		Adjustable	
	psig	bar	psig	bar
M8 x 1	5800	400	4568	315
M10 x 1				
M12 x 1.5				
M14 x 1.5				
M16 x 1.5	4568	315	3626	250
M18 x 1.5				
M20 x 1.5				
M22 x 1.5				
M27 x 2	2900	200	2320	160
M30 x 2				
M33 x 2				
M42 x 2				
M48 x 2				
M60 x 2	2320	160	1450	100

Working pressures are based on ISO 6149-3 at ambient temperature.

Working Temperatures

Thread Ends

The working temperatures of the thread ends may be limited by the Teflon tape or thread sealant or, when applicable, the gaskets or O-rings as follows:

Component	Material	Minimum Temperature	Maximum Temperature
RS gasket	Buna N	-13° F (-25° C)	230° F (110° C)
	Fluorocarbon FKM	5° F (-15° C)	400° F (204° C)
RP/RG Gasket	Copper	-325° F (-198° C)	400° F (204° C)
	Stainless Steel	-425° F (-254° C)	1000° F (538° C)
RG Gasket	PTFE	-65° F (-54° C)	450° F (232° C)
	Vulcanized Fibre	-76° F (-60° C)	221° F (105° C)
O-ring	Buna N	-22° F (-30° C)	230° F (110° C)
	Fluorocarbon FKM	-4° F (-20° C)	400° F (204° C)

⦿ Working Pressures

- ⦿ The maximum working pressures of the tube ends at ambient temperature are determined by the maximum working pressure of the FITOK Tubing that is used. Refer to *Tubing* on F-02.
- ⦿ The maximum working pressures of the thread ends at ambient temperature are stated as above.
- ⦿ To get the maximum working pressure at elevated temperature, use the maximum working pressure at ambient temperature to multiply the factors in the table of Elevated Temperature Factors on F-14.
- ⦿ The maximum working pressure of the whole fitting is determined by the end connection with the lowest pressure rating.

Materials

Material	Bar Stock	Forging	Designator
316 stainless steel	ASTM A479, ASME SA479, EN 1.4401	ASTM A182, ASME SA182, EN 1.4401	SS
316L stainless steel	ASTM A479, ASME SA479, EN 1.4404	ASTM A182, ASME SA182, EN 1.4404	6L
304 stainless steel	ASTM A479, ASME SA479, EN 1.4301	ASTM A182, ASME SA182, EN 1.4301	S4
321 stainless steel	ASTM A479, ASME SA479, EN 1.4541	ASTM A182, ASME SA182, EN 1.4541	S1
316Ti stainless steel	ASTM A479, ASME SA479, EN 1.4571	ASTM A182, ASME SA182, EN 1.4571	6T
6Mo (S31254)	ASTM A479	ASTM A182	S12
904L stainless steel	ASTM A479	ASTM A182	904L
Titanium (grade 4)	ASTM B348	ASTM B381	TI
Duplex 2205	ASTM A479	ASTM A182	D5
Super duplex 2507	ASTM A479	ASTM A182	D7
Alloy 20	ASTM A479	ASTM B462	A20
Alloy 400	ASTM B164, ASME SB164	ASTM B564, ASME SB564	M
Alloy 600	ASTM B166, ASME SB166	ASTM B564, ASME SB564	INC
Alloy 625	ASTM B446	ASTM B564, ASME SB564	A65
Alloy 718	ASTM B637	ASTM B637	A78
Alloy 825	ASTM B425	ASTM B564	A85
Alloy C-276	ASTM B574	ASTM B564	HC
Carbon steel	ASTM A108	ASTM A105	CS
Brass	ASTM B16/B453	ASTM B283	B
Nylon	ASTM D4066	/	PA
PTFE	ASTM D1710	/	T

Note: Normal materials in boldface letter can be supplied rapidly; other materials need make to order, for lead time please contact FITOK Group.

Installation Instructions

- ⊙ FITOK Tube Fittings up to 1" or 25 mm
 1. Loosen the nut 1/4 turn from finger-tight position.
 2. Insert tubing into the tube fitting, make sure that the tubing rests firmly on the shoulder of the port.
 3. Finger-tighten the nut.
 4. Tighten the nut 1 1/4 turns with wrench while holding the body of the fitting or the valve steady (Fig.1).
For small-sized fittings (1/16", 1/8" and 3/16", 2 mm, 3 mm and 4 mm), tighten the nut 3/4 turn with wrench (Fig.2).
- ⊙ FITOK Tube Fittings over 1" or 25 mm
 1. Use presetting tool to install the ferrules onto the tube, please refer to the instruction of Hydraulic Presetting Tool for details.
 2. Insert the preset tubing with ferrules and nut into the body of fitting, finger tight.
 3. Tighten the nut one-half turn with wrench.
- ⊙ Reinstallation (all sizes)
 1. Mark the tube at the back of the nut, mark a line along the nut and fitting body flats.
 2. Insert tubing with preset ferrules into the fitting body until the front ferrule seats.
 3. Then rotate the nut with a wrench to the previous pulled-up position as indicated by the marks on the tube and the flats.
 4. Tighten the nut slightly with wrench.
- ⊙ Plugs and Port Connectors
 1. Tighten the plug or port connector 1/4 turn from the finger-tight position while holding the body of the fitting steady.
For small-sized fittings (1/16", 1/8" and 3/16", 2 mm, 3 mm and 4 mm), tighten the nut 1/8 turn with wrench.
 2. Reinstallation: Tighten slightly with a wrench from the finger-tight position.
The Installation Instructions of the tube adapter end of Port Connectors are the same as the FITOK Tube Fittings.

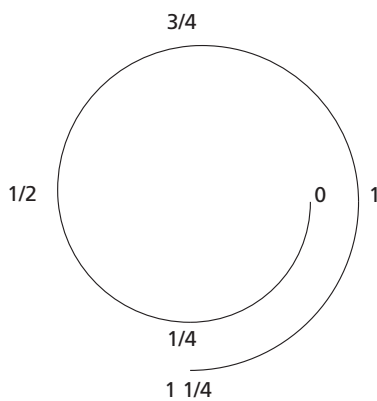

Fig.1

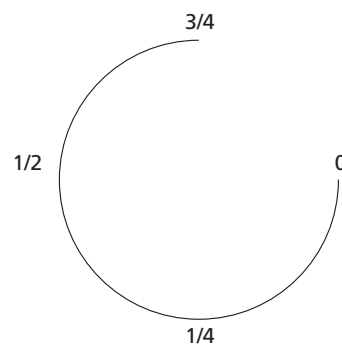

Fig.2

Cautions:

- ⊙ Do not loosen or tighten fittings when the system is pressurized.
- ⊙ Make sure that the tubing rests firmly on the shoulder of the port.
- ⊙ Always leave enough straight length of the tubing for the fittings.
- ⊙ Always use an insert for extremely soft plastic tubing.
- ⊙ Material of the metal tubing should be softer than that of the fitting. For example, stainless steel tubing should not be used with brass fittings. When tubing and fittings are made of the same material, the tubing must be fully annealed.
- ⊙ The allowable working pressure of the tube fitting is rated to the maximum working pressure of the corresponding tubing, which can be found in FITOK tubing data sheet. For those which can not be found in FITOK tubing data sheet, please contact FITOK Group or our authorized distributors for related information.
- ⊙ Keep the tubing end and surface clean and smooth.
- ⊙ Always use proper thread sealants on tapered pipe threads. Make sure that its working temperature does not exceed that of the sealants.
- ⊙ When assembling the tube fitting, hold the body with a wrench and turn the nut instead of holding the nut.
- ⊙ When installing a valve with tube fitting end, hold the valve body with a wrench and turn the nut.
- ⊙ When assembling the fitting to a valve with thread, hold the valve body with a wrench and turn the body of the fitting.

Dimensions

1. Dimensions are for reference only and are subject to change; Dimensions are shown with FITOK nuts finger-tight.
2. The E dimension refers to the smallest nominal orifice. It might be larger at tapered thread end, straight thread end and welding end.

Male Connectors

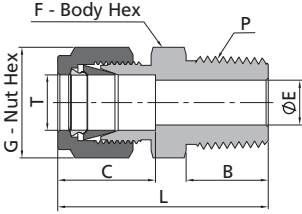

Fractional Tube			NPT Thread					
T-Tube O.D. (in.)	P-NPT Size	Basic Ordering Number	Dimensions, in. (mm)					
			L	B	C	E	G	F
1/16	1/16	-CM-FL1-NS1	0.94(23.9)	0.38(9.7)	0.34(8.6)	0.05(1.3)	0.31(7.9)	0.31(7.9)
1/16	1/8	-CM-FL1-NS2	1.03(26.2)	0.38(9.7)	0.34(8.6)	0.05(1.3)	0.31(7.9)	0.44(11.1)
1/16	1/4	-CM-FL1-NS4	1.22(31.0)	0.56(14.2)	0.34(8.6)	0.05(1.3)	0.31(7.9)	0.56(14.3)
1/8	1/16	-CM-FL2-NS1	1.17(29.7)	0.38(9.7)	0.50(12.7)	0.09(2.3)	0.44(11.1)	0.44(11.1)
1/8	1/8	-CM-FL2-NS2	1.20(30.5)	0.38(9.7)	0.50(12.7)	0.09(2.3)	0.44(11.1)	0.44(11.1)
1/8	1/4	-CM-FL2-NS4	1.40(35.6)	0.56(14.2)	0.50(12.7)	0.09(2.3)	0.44(11.1)	0.56(14.3)
1/8	3/8	-CM-FL2-NS6	1.41(35.8)	0.56(14.2)	0.50(12.7)	0.09(2.3)	0.44(11.1)	0.69(17.5)
1/8	1/2	-CM-FL2-NS8	1.66(42.2)	0.75(19.1)	0.50(12.7)	0.09(2.3)	0.44(11.1)	0.87(22.2)
3/16	1/16	-CM-FL3-NS1	1.23(31.2)	0.38(9.7)	0.54(13.7)	0.12(3.0)	0.50(12.7)	0.44(11.1)
3/16	1/8	-CM-FL3-NS2	1.23(31.2)	0.38(9.7)	0.54(13.7)	0.12(3.0)	0.50(12.7)	0.44(11.1)
3/16	1/4	-CM-FL3-NS4	1.43(36.3)	0.56(14.2)	0.54(13.7)	0.12(3.0)	0.50(12.7)	0.56(14.3)
1/4	1/16	-CM-FL4-NS1	1.29(32.8)	0.38(9.7)	0.60(15.2)	0.12(3.0)	0.56(14.3)	0.50(12.7)
1/4	1/8	-CM-FL4-NS2	1.29(32.8)	0.38(9.7)	0.60(15.2)	0.19(4.8)	0.56(14.3)	0.50(12.7)
1/4	1/4	-CM-FL4-NS4	1.49(37.8)	0.56(14.2)	0.60(15.2)	0.19(4.8)	0.56(14.3)	0.56(14.3)
1/4	3/8	-CM-FL4-NS6	1.51(38.4)	0.56(14.2)	0.60(15.2)	0.19(4.8)	0.56(14.3)	0.69(17.5)
1/4	1/2	-CM-FL4-NS8	1.76(44.7)	0.75(19.1)	0.60(15.2)	0.19(4.8)	0.56(14.3)	0.87(22.2)
1/4	3/4	-CM-FL4-NS12	1.82(46.2)	0.75(19.1)	0.60(15.2)	0.19(4.8)	0.56(14.3)	1.06(27.0)
5/16	1/8	-CM-FL5-NS2	1.34(34.0)	0.38(9.7)	0.64(16.3)	0.19(4.8)	0.63(15.9)	0.56(14.3)
5/16	1/4	-CM-FL5-NS4	1.52(38.6)	0.38(9.7)	0.64(16.3)	0.25(6.4)	0.63(15.9)	0.56(14.3)
5/16	3/8	-CM-FL5-NS6	1.54(39.1)	0.56(14.2)	0.64(16.3)	0.25(6.4)	0.63(15.9)	0.69(17.5)
5/16	1/2	-CM-FL5-NS8	1.79(45.5)	0.75(19.1)	0.64(16.3)	0.25(6.4)	0.63(15.9)	0.87(22.2)
3/8	1/8	-CM-FL6-NS2	1.39(35.3)	0.38(9.7)	0.66(16.8)	0.19(4.8)	0.69(17.5)	0.63(15.9)
3/8	1/4	-CM-FL6-NS4	1.57(39.9)	0.56(14.2)	0.66(16.8)	0.28(7.1)	0.69(17.5)	0.63(15.9)
3/8	3/8	-CM-FL6-NS6	1.57(39.9)	0.56(14.2)	0.66(16.8)	0.28(7.1)	0.69(17.5)	0.69(17.5)
3/8	1/2	-CM-FL6-NS8	1.82(46.2)	0.75(19.1)	0.66(16.8)	0.28(7.1)	0.69(17.5)	0.87(22.2)
3/8	3/4	-CM-FL6-NS12	1.88(47.8)	0.75(19.1)	0.66(16.8)	0.28(7.1)	0.69(17.5)	1.06(27.0)
3/8	1	-CM-FL6-NS16	2.14(54.4)	0.94(23.9)	0.66(16.8)	0.28(7.1)	0.69(17.5)	1.37(34.9)
1/2	1/8	-CM-FL8-NS2	1.53(38.9)	0.38(9.7)	0.90(22.9)	0.19(4.8)	0.87(22.2)	0.81(20.6)
1/2	1/4	-CM-FL8-NS4	1.71(43.4)	0.56(14.2)	0.90(22.9)	0.28(7.1)	0.87(22.2)	0.81(20.6)
1/2	3/8	-CM-FL8-NS6	1.71(43.4)	0.56(14.2)	0.90(22.9)	0.38(9.7)	0.87(22.2)	0.81(20.6)
1/2	1/2	-CM-FL8-NS8	1.93(49.0)	0.75(19.1)	0.90(22.9)	0.41(10.4)	0.87(22.2)	0.87(22.2)
1/2	3/4	-CM-FL8-NS12	1.99(50.5)	0.75(19.1)	0.90(22.9)	0.41(10.4)	0.87(22.2)	1.06(27.0)
1/2	1	-CM-FL8-NS16	2.25(57.2)	0.94(23.9)	0.90(22.9)	0.41(10.4)	0.87(22.2)	1.37(34.9)
5/8	1/4	-CM-FL10-NS4	1.74(44.2)	0.56(14.2)	0.96(24.4)	0.28(7.1)	1.00(25.4)	0.94(23.8)
5/8	3/8	-CM-FL10-NS6	1.74(44.2)	0.56(14.2)	0.96(24.4)	0.38(9.7)	1.00(25.4)	0.94(23.8)
5/8	1/2	-CM-FL10-NS8	1.93(49.0)	0.75(19.1)	0.96(24.4)	0.47(11.9)	1.00(25.4)	0.94(23.8)
5/8	3/4	-CM-FL10-NS12	1.99(50.5)	0.75(19.1)	0.96(24.4)	0.50(12.7)	1.00(25.4)	1.06(27.0)
3/4	3/8	-CM-FL12-NS6	1.80(45.7)	0.56(14.2)	0.96(24.4)	0.41(10.4)	1.13(28.6)	1.06(27.0)
3/4	1/2	-CM-FL12-NS8	1.99(50.5)	0.75(19.1)	0.96(24.4)	0.47(11.9)	1.13(28.6)	1.06(27.0)
3/4	3/4	-CM-FL12-NS12	1.99(50.5)	0.75(19.1)	0.96(24.4)	0.62(15.7)	1.13(28.6)	1.06(27.0)
3/4	1	-CM-FL12-NS16	2.25(57.2)	0.94(23.9)	0.96(24.4)	0.62(15.7)	1.13(28.6)	1.37(34.9)
7/8	1/2	-CM-FL14-NS8	1.99(50.5)	0.75(19.1)	1.02(25.9)	0.47(11.9)	1.25(31.8)	1.19(30.2)
7/8	3/4	-CM-FL14-NS12	1.99(50.5)	0.75(19.1)	1.02(25.9)	0.62(15.7)	1.25(31.8)	1.19(30.2)
7/8	1	-CM-FL14-NS16	2.25(57.2)	0.94(23.9)	1.02(25.9)	0.72(18.3)	1.25(31.8)	1.37(34.9)
1	1/2	-CM-FL16-NS8	2.26(57.4)	0.75(19.1)	1.23(31.2)	0.47(11.9)	1.50(38.1)	1.37(34.9)
1	3/4	-CM-FL16-NS12	2.26(57.4)	0.75(19.1)	1.23(31.2)	0.62(15.7)	1.50(38.1)	1.37(34.9)
1	1	-CM-FL16-NS16	2.45(62.2)	0.94(23.9)	1.23(31.2)	0.88(22.4)	1.50(38.1)	1.37(34.9)
1 1/8	1	-CM-FL18-NS16	2.45(62.2)	0.94(23.9)	1.44(36.7)	0.88(22.4)	1.75(44.5)	1.63(41.3)
1 1/4	1	-CM-FL20-NS16	3.04(77.2)	0.94(23.9)	1.62(41.1)	0.88(22.4)	1.87(47.6)	1.75(44.5)
1 1/4	1 1/4	-CM-FL20-NS20	3.04(77.2)	0.94(23.9)	1.62(41.1)	1.09(27.7)	1.87(47.6)	1.75(44.5)
1 1/2	1 1/2	-CM-FL24-NS24	3.50(88.9)	1.03(26.2)	1.97(50.0)	1.34(34.0)	2.25(57.2)	2.13(54.0)

A-14 6 Series Tube Fittings

Male Connectors

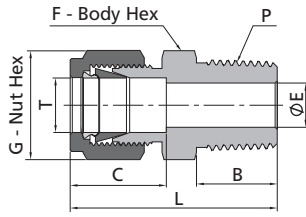

Fractional Tube			ISO Tapered Thread (RT)						
T-Tube O.D. (in.)	P-RT Size	Basic Ordering Number	Dimensions, in. (mm)						
			L	B	C	E	G	F	
1/8	1/8	-CM-FL2-RT2	1.20(30.5)	0.38(9.7)	0.50(12.7)	0.09(2.3)	0.44(11.1)	0.44(11.1)	
1/8	1/4	-CM-FL2-RT4	1.40(35.6)	0.56(14.2)	0.50(12.7)	0.09(2.3)	0.44(11.1)	0.56(14.3)	
1/4	1/8	-CM-FL4-RT2	1.29(32.8)	0.38(9.7)	0.60(15.2)	0.19(4.8)	0.56(14.3)	0.50(12.7)	
1/4	1/4	-CM-FL4-RT4	1.49(37.8)	0.56(14.2)	0.60(15.2)	0.19(4.8)	0.56(14.3)	0.56(14.3)	
1/4	3/8	-CM-FL4-RT6	1.51(38.4)	0.56(14.2)	0.60(15.2)	0.19(4.8)	0.56(14.3)	0.69(17.5)	
1/4	1/2	-CM-FL4-RT8	1.76(44.7)	0.75(19.1)	0.60(15.2)	0.19(4.8)	0.56(14.3)	0.87(22.2)	
5/16	1/8	-CM-FL5-RT2	1.34(34.0)	0.38(9.7)	0.64(16.3)	0.19(4.8)	0.63(15.9)	0.56(14.3)	
5/16	1/4	-CM-FL5-RT4	1.52(38.6)	0.56(14.2)	0.64(16.3)	0.25(6.4)	0.63(15.9)	0.56(14.3)	
3/8	1/8	-CM-FL6-RT2	1.39(35.3)	0.38(9.7)	0.66(16.8)	0.19(4.8)	0.69(17.5)	0.63(15.9)	
3/8	1/4	-CM-FL6-RT4	1.57(39.9)	0.56(14.2)	0.66(16.8)	0.28(7.1)	0.69(17.5)	0.63(15.9)	
3/8	3/8	-CM-FL6-RT6	1.57(39.9)	0.56(14.2)	0.66(16.8)	0.28(7.1)	0.69(17.5)	0.69(17.5)	
3/8	1/2	-CM-FL6-RT8	1.82(46.2)	0.75(19.1)	0.66(16.8)	0.28(7.1)	0.69(17.5)	0.87(22.2)	
3/8	3/4	-CM-FL6-RT12	1.88(47.8)	0.75(19.1)	0.66(16.8)	0.28(7.1)	0.69(17.5)	1.06(27.0)	
1/2	1/4	-CM-FL8-RT4	1.71(43.4)	0.56(14.2)	0.90(22.9)	0.28(7.1)	0.87(22.2)	0.81(20.6)	
1/2	3/8	-CM-FL8-RT6	1.71(43.4)	0.56(14.2)	0.90(22.9)	0.38(9.7)	0.87(22.2)	0.81(20.6)	
1/2	1/2	-CM-FL8-RT8	1.93(49.0)	0.75(19.1)	0.90(22.9)	0.41(10.4)	0.87(22.2)	0.87(22.2)	
1/2	3/4	-CM-FL8-RT12	1.99(50.5)	0.75(19.1)	0.90(22.9)	0.41(10.4)	0.87(22.2)	1.06(27.0)	
5/8	1/2	-CM-FL10-RT8	1.93(49.0)	0.75(19.1)	0.96(24.4)	0.47(11.9)	1.00(25.4)	0.94(23.8)	
3/4	3/4	-CM-FL12-RT12	1.99(50.5)	0.75(19.1)	0.96(24.4)	0.62(15.7)	1.13(28.6)	1.06(27.0)	
3/4	1	-CM-FL12-RT16	2.25(57.2)	0.94(23.9)	0.96(24.4)	0.62(15.7)	1.13(28.6)	1.37(34.9)	
1	3/4	-CM-FL16-RT12	2.26(57.4)	0.75(19.1)	1.23(31.2)	0.62(15.7)	1.50(38.1)	1.37(34.9)	
1	1	-CM-FL16-RT16	2.45(62.2)	0.94(23.9)	1.23(31.2)	0.88(22.4)	1.50(38.1)	1.37(34.9)	

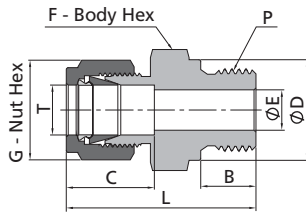

Fractional Tube			ISO Parallel Thread (RS)						
T-Tube O.D. (in.)	P-RS Size	Basic Ordering Number	Dimensions, in. (mm)						
			L	B	C	E	G	F	D
1/8	1/8	-CM-FL2-RS2	1.18(30.0)	0.28(7.1)	0.50(12.7)	0.09(2.3)	0.44(11.1)	0.56(14.3)	0.54(13.7)
1/8	1/4	-CM-FL2-RS4	1.39(35.3)	0.44(11.2)	0.50(12.7)	0.09(2.3)	0.44(11.1)	0.75(19.1)	0.71(18.0)
1/8	3/8	-CM-FL2-RS6	1.43(36.3)	0.44(11.2)	0.50(12.7)	0.09(2.3)	0.44(11.1)	0.87(22.2)	0.86(21.8)
1/4	1/8	-CM-FL4-RS2	1.27(32.3)	0.28(7.1)	0.60(15.2)	0.16(4.0)	0.56(14.3)	0.56(14.3)	0.54(13.7)
1/4	1/4	-CM-FL4-RS4	1.48(37.6)	0.44(11.2)	0.60(15.2)	0.19(4.8)	0.56(14.3)	0.75(19.1)	0.71(18.0)
1/4	3/8	-CM-FL4-RS6	1.53(38.9)	0.44(11.2)	0.60(15.2)	0.19(4.8)	0.56(14.3)	0.87(22.2)	0.86(21.8)
1/4	1/2	-CM-FL4-RS8	1.76(44.7)	0.56(14.2)	0.60(15.2)	0.19(4.8)	0.56(14.3)	1.06(27.0)	1.02(25.9)
3/8	1/8	-CM-FL6-RS2	1.49(37.8)	0.28(7.1)	0.66(16.8)	0.16(4.0)	0.69(17.5)	0.63(15.9)	0.54(13.7)
3/8	1/4	-CM-FL6-RS4	1.54(39.1)	0.44(11.2)	0.66(16.8)	0.23(5.9)	0.69(17.5)	0.75(19.1)	0.71(18.0)
3/8	3/8	-CM-FL6-RS6	1.59(40.4)	0.44(11.2)	0.66(16.8)	0.28(7.1)	0.69(17.5)	0.87(22.2)	0.86(21.8)
3/8	1/2	-CM-FL6-RS8	1.82(46.2)	0.56(14.2)	0.66(16.8)	0.28(7.1)	0.69(17.5)	1.06(27.0)	1.02(25.9)
1/2	1/4	-CM-FL8-RS4	1.68(42.7)	0.44(11.2)	0.90(22.9)	0.23(5.9)	0.87(22.2)	0.81(20.6)	0.71(18.0)
1/2	3/8	-CM-FL8-RS6	1.70(43.2)	0.44(11.2)	0.90(22.9)	0.31(7.9)	0.87(22.2)	0.87(22.2)	0.86(21.8)
1/2	1/2	-CM-FL8-RS8	1.93(49.0)	0.56(14.2)	0.90(22.9)	0.41(10.4)	0.87(22.2)	1.06(27.0)	1.02(25.9)
3/4	1/2	-CM-FL12-RS8	1.93(49.0)	0.56(14.2)	0.96(24.4)	0.47(11.9)	1.13(28.6)	1.06(27.0)	1.02(25.9)
3/4	3/4	-CM-FL12-RS12	2.08(52.9)	0.62(15.7)	0.96(24.4)	0.62(15.7)	1.13(28.6)	1.31(33.3)	1.26(32.0)
1	1/2	-CM-FL16-RS8	2.19(55.5)	0.56(14.2)	1.23(31.2)	0.47(11.9)	1.50(38.1)	1.37(34.9)	1.02(25.9)
1	3/4	-CM-FL16-RS12	2.27(57.7)	0.62(15.7)	1.23(31.2)	0.63(16.0)	1.50(38.1)	1.37(34.9)	1.26(32.0)
1	1	-CM-FL16-RS16	2.36(59.9)	0.72(18.3)	1.23(31.2)	0.78(19.8)	1.50(38.1)	1.63(41.3)	1.54(39.1)

Male Connectors

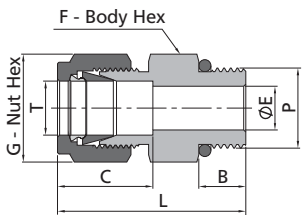
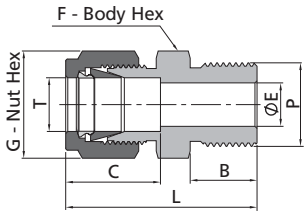
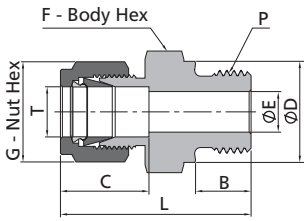

Adapt to straight thread boss of SAE J1926-1, ISO 11926-1 and MS 16142.

Fractional Tube			ISO Parallel Thread (RP)						
T-Tube O.D. (in.)	P-RP Size	Basic Ordering Number	Dimensions, in. (mm)						
			L	B	C	E	G	F	D
1/8	1/8	-CM-FL2-RP2	1.18(30.0)	0.28(7.1)	0.50(12.7)	0.09(2.3)	0.44(11.1)	0.56(14.3)	0.54(13.8)
1/8	1/4	-CM-FL2-RP4	1.39(35.3)	0.44(11.2)	0.50(12.7)	0.09(2.3)	0.44(11.1)	0.75(19.1)	0.70(17.8)
1/4	1/8	-CM-FL4-RP2	1.27(32.3)	0.28(7.1)	0.60(15.2)	0.16(4.1)	0.56(14.3)	0.56(14.3)	0.54(13.8)
1/4	1/4	-CM-FL4-RP4	1.48(37.6)	0.44(11.2)	0.60(15.2)	0.19(4.8)	0.56(14.3)	0.75(19.1)	0.70(17.8)
1/2	3/8	-CM-FL8-RP6	1.79(45.5)	0.44(11.2)	0.90(22.9)	0.31(7.9)	0.87(22.2)	0.87(22.2)	0.86(21.8)
1/2	1/2	-CM-FL8-RP8	1.93(49.0)	0.56(14.2)	0.90(22.9)	0.41(10.4)	0.87(22.2)	1.06(27.0)	1.02(25.9)
3/4	1/2	-CM-FL12-RP8	1.93(49.0)	0.56(14.2)	0.96(24.4)	0.47(11.9)	1.13(28.6)	1.06(27.0)	1.02(25.9)
3/4	3/4	-CM-FL12-RP12	2.08(52.9)	0.62(15.7)	0.96(24.4)	0.62(15.7)	1.13(28.6)	1.31(33.3)	1.26(32.0)
1	1	-CM-FL16-RP16	2.36(59.9)	0.72(18.3)	1.23(31.2)	0.78(19.8)	1.50(38.1)	1.63(41.3)	1.53(38.8)

Fractional Tube			ISO Parallel Thread (BP)					
T-Tube O.D. (in.)	P-BP Size	Basic Ordering Number	Dimensions, in. (mm)					
			L	B	C	E	G	F
1/4	3/8	-CM-FL4-BP6	1.51(38.4)	0.56(14.2)	0.60(15.2)	0.19(4.8)	0.56(14.3)	0.69(17.5)
3/8	3/8	-CM-FL6-BP6	1.57(39.9)	0.56(14.2)	0.66(16.8)	0.28(7.1)	0.69(17.5)	0.69(17.5)

Fractional Tube			SAE/MS Straight Thread					
T-Tube O.D. (in.)	P-SAE/MS Thread Size	Basic Ordering Number	Dimensions, in. (mm)					
			L	B	C	E	G	F
1/16	5/16-24	-CM-FL1-ST5	0.92(23.4)	0.30(7.6)	0.34(8.6)	0.05(1.3)	0.31(7.9)	0.44(11.1)
1/8	5/16-24	-CM-FL2-ST5	1.18(30.0)	0.30(7.6)	0.50(12.7)	0.09(2.3)	0.44(11.1)	0.44(11.1)
1/8	7/16-20	-CM-FL2-ST7	1.24(31.5)	0.36(9.1)	0.50(12.7)	0.09(2.3)	0.44(11.1)	0.56(14.3)
1/8	9/16-18	-CM-FL2-ST9	1.31(33.3)	0.39(9.9)	0.50(12.7)	0.09(2.3)	0.44(11.1)	0.69(17.5)
3/16	3/8-24	-CM-FL3-ST6	1.20(30.5)	0.30(7.6)	0.54(13.7)	0.12(3.0)	0.50(12.7)	0.50(12.7)
1/4	5/16-24	-CM-FL4-ST5	1.27(32.3)	0.30(7.6)	0.60(15.2)	0.12(3.0)	0.56(14.3)	0.50(12.7)
1/4	7/16-20	-CM-FL4-ST7	1.34(34.0)	0.36(9.1)	0.60(15.2)	0.19(4.8)	0.56(14.3)	0.56(14.3)
1/4	9/16-18	-CM-FL4-ST9	1.40(35.6)	0.39(9.9)	0.60(15.2)	0.19(4.8)	0.56(14.3)	0.69(17.5)
1/4	3/4-16	-CM-FL4-ST12	1.48(37.6)	0.44(11.2)	0.60(15.2)	0.19(4.8)	0.56(14.3)	0.87(22.2)
1/4	7/8-14	-CM-FL4-ST14	1.60(40.6)	0.50(12.7)	0.60(15.2)	0.19(4.8)	0.56(14.3)	1.00(25.4)
5/16	1/2-20	-CM-FL5-ST8	1.37(34.8)	0.36(9.1)	0.64(16.3)	0.25(6.4)	0.63(15.9)	0.63(15.9)
3/8	7/16-20	-CM-FL6-ST7	1.40(35.6)	0.36(9.1)	0.66(16.8)	0.20(5.1)	0.69(17.5)	0.63(15.9)
3/8	9/16-18	-CM-FL6-ST9	1.46(37.1)	0.39(9.9)	0.66(16.8)	0.28(7.1)	0.69(17.5)	0.69(17.5)
3/8	3/4-16	-CM-FL6-ST12	1.54(39.1)	0.44(11.2)	0.66(16.8)	0.28(7.1)	0.69(17.5)	0.87(22.2)
3/8	7/8-14	-CM-FL6-ST14	1.66(42.2)	0.50(12.7)	0.66(16.8)	0.28(7.1)	0.69(17.5)	1.00(25.4)
1/2	9/16-18	-CM-FL8-ST9	1.54(39.1)	0.39(9.9)	0.90(22.9)	0.28(7.1)	0.87(22.2)	0.81(20.6)
1/2	3/4-16	-CM-FL8-ST12	1.65(41.9)	0.44(11.2)	0.90(22.9)	0.41(10.4)	0.87(22.2)	0.87(22.2)
1/2	7/8-14	-CM-FL8-ST14	1.77(45.0)	0.50(12.7)	0.90(22.9)	0.41(10.4)	0.87(22.2)	1.00(25.4)
1/2	1 1/16-12	-CM-FL8-ST17	1.93(49.0)	0.59(15.0)	0.90(22.9)	0.41(10.4)	0.87(22.2)	1.25(31.8)
5/8	3/4-16	-CM-FL10-ST12	1.65(41.9)	0.44(11.2)	0.96(24.4)	0.42(10.7)	1.00(25.4)	0.94(23.8)
5/8	7/8-14	-CM-FL10-ST14	1.78(45.2)	0.50(12.7)	0.96(24.4)	0.50(12.7)	1.00(25.4)	1.00(25.4)
3/4	3/4-16	-CM-FL12-ST12	1.81(46.0)	0.44(11.2)	0.96(24.4)	0.42(10.7)	1.13(28.6)	1.06(27.0)
3/4	1 1/16-12	-CM-FL12-ST17	1.93(49.0)	0.59(15.0)	0.96(24.4)	0.62(15.7)	1.13(28.6)	1.25(31.8)
3/4	1 5/16-12	-CM-FL12-ST21	1.96(49.8)	0.59(15.0)	0.96(24.4)	0.63(16.0)	1.13(28.6)	1.50(38.1)
7/8	1 3/16-12	-CM-FL14-ST19	1.93(49.0)	0.59(15.0)	1.02(25.9)	0.72(18.3)	1.25(31.8)	1.37(34.9)
1	1 1/16-12	-CM-FL16-ST17	2.10(53.3)	0.59(15.0)	1.23(31.2)	0.66(16.8)	1.50(38.1)	1.37(34.9)
1	1 5/16-12	-CM-FL16-ST21	2.14(54.4)	0.59(15.0)	1.23(31.2)	0.88(22.4)	1.50(38.1)	1.50(38.1)
1 1/4	1 5/8-12	-CM-FL20-ST26	2.69(68.3)	0.59(15.0)	1.62(41.1)	1.09(27.7)	1.87(47.6)	1.87(47.6)
1 1/2	1 7/8-12	-CM-FL24-ST30	3.06(77.7)	0.59(15.0)	1.97(50.0)	1.34(34.0)	2.25(57.2)	2.13(54.0)

A-16 6 Series Tube Fittings

Male Connectors

Tube Fittings

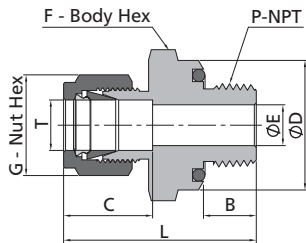
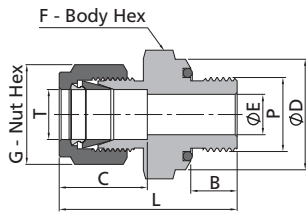
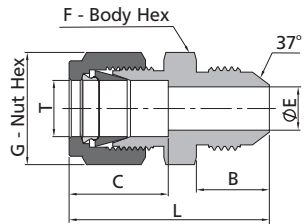
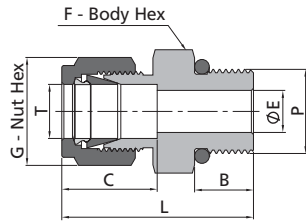

Fractional Tube			SAE/MS Straight Thread						
T-Tube O.D. (in.)	P-SAE/MS Thread Size	Basic Ordering Number	Dimensions, in. (mm)						
			L	B	C	E	G	F	
1/4	7/16-20	-CML-FL4-ST7	2.26(57.4)	0.36(9.1)	0.60(15.2)	0.19(4.8)	0.56(14.3)	0.56(14.3)	
1/2	3/4-16	-CML-FL8-ST12	3.01(76.5)	0.44(11.2)	0.90(22.9)	0.41(10.4)	0.87(22.2)	0.87(22.2)	

Fractional Tube			37° Flare (AN)						
T-Tube O.D. (in.)	AN Tube Flare Size	Basic Ordering Number	Dimensions, in. (mm)						
			L	B	C	E	G	F	
1/16	1/8	-CM-FL1-AN2	1.07(27.2)	0.45(11.4)	0.34(8.6)	0.05(1.3)	0.31(7.9)	0.44(11.1)	
1/8	1/8	-CM-FL2-AN2	1.27(32.3)	0.45(11.4)	0.50(12.7)	0.06(1.5)	0.44(11.1)	0.44(11.1)	
1/8	1/4	-CM-FL2-AN4	1.38(35.1)	0.55(14.0)	0.50(12.7)	0.09(2.3)	0.44(11.1)	0.50(12.7)	
3/16	3/16	-CM-FL3-AN3	1.32(33.5)	0.48(12.2)	0.54(13.7)	0.12(3.0)	0.50(12.7)	0.44(11.1)	
1/4	1/4	-CM-FL4-AN4	1.48(37.6)	0.55(14.0)	0.60(15.2)	0.17(4.3)	0.56(14.3)	0.50(12.7)	
5/16	5/16	-CM-FL5-AN5	1.51(38.4)	0.55(14.0)	0.64(16.2)	0.23(5.8)	0.63(15.9)	0.56(14.3)	
3/8	1/4	-CM-FL6-AN4	1.56(39.6)	0.55(14.0)	0.66(16.8)	0.17(4.3)	0.69(17.5)	0.63(15.9)	
3/8	3/8	-CM-FL6-AN6	1.56(39.6)	0.56(14.1)	0.66(16.8)	0.28(7.1)	0.69(17.5)	0.63(15.9)	
1/2	1/2	-CM-FL8-AN8	1.81(46.0)	0.66(16.7)	0.90(22.8)	0.39(9.9)	0.87(22.2)	0.81(20.6)	
5/8	5/8	-CM-FL10-AN10	1.93(49.0)	0.76(19.3)	0.96(24.5)	0.48(12.3)	1.00(25.4)	0.94(23.8)	
3/4	3/4	-CM-FL12-AN12	2.10(53.3)	0.86(21.9)	0.96(24.4)	0.61(15.5)	1.13(28.6)	1.13(28.6)	
1	1	-CM-FL16-AN16	2.42(61.5)	0.91(23.1)	1.23(31.2)	0.84(21.3)	1.50(38.1)	1.37(34.9)	

Fractional Tube			O-Seal with SAE/MS Straight Thread						
T-Tube O.D. (in.)	P-SAE/MS Thread Size	Basic Ordering Number	Dimensions, in. (mm)						
			L	B	C	E	G	F	D
1/16	5/16-24	-CM-FL1-OST5	1.05(26.7)	0.34(8.6)	0.34(8.6)	0.05(1.3)	0.31(7.9)	0.56(14.3)	0.55(14.0)
1/8	5/16-24	-CM-FL2-OST5	1.29(32.8)	0.34(8.6)	0.50(12.7)	0.09(2.3)	0.44(11.1)	0.56(14.3)	0.55(14.0)
3/16	3/8-24	-CM-FL3-OST6	1.35(34.3)	0.38(9.7)	0.54(13.7)	0.12(3.0)	0.50(12.7)	0.63(15.9)	0.62(15.7)
1/4	7/16-20	-CM-FL4-OST7	1.51(38.4)	0.41(10.4)	0.60(15.2)	0.19(4.8)	0.56(14.3)	0.75(19.1)	0.74(18.8)
5/16	1/2-20	-CM-FL5-OST8	1.60(40.6)	0.44(11.2)	0.64(16.3)	0.25(6.4)	0.63(15.9)	0.87(22.2)	0.86(21.8)
3/8	9/16-18	-CM-FL6-OST9	1.67(42.4)	0.47(11.9)	0.66(16.8)	0.28(7.1)	0.69(17.5)	0.94(23.8)	0.93(23.6)
1/2	3/4-16	-CM-FL8-OST12	1.81(46.0)	0.47(11.9)	0.90(22.9)	0.41(10.4)	0.87(22.2)	1.13(28.6)	1.12(28.4)
3/4	1 1/16-12	-CM-FL12-OST17	2.06(52.3)	0.56(14.2)	0.96(24.4)	0.62(15.7)	1.13(28.6)	1.50(38.1)	1.49(37.8)
1	1 5/16-12	-CM-FL16-OST21	2.29(58.2)	0.56(14.2)	1.23(31.2)	0.88(22.4)	1.50(38.1)	1.75(44.5)	1.74(44.2)

Fractional Tube			O-Seal with NPT Thread						
T-Tube O.D. (in.)	P-NPT Size	Basic Ordering Number	Dimensions, in. (mm)						
			L	B	C	E	G	F	D
1/8	1/8	-CM-FL2-ONS2	1.29(32.8)	0.28(7.1)	0.34(8.6)	0.09(2.3)	0.47(11.9)	0.75(19.1)	0.74(18.8)
1/4	1/8	-CM-FL4-ONS2	1.38(35.1)	0.28(7.1)	0.60(15.2)	0.19(4.8)	0.56(14.3)	0.75(19.1)	0.74(18.8)
1/4	1/4	-CM-FL4-ONS4	1.51(38.4)	0.38(9.7)	0.60(15.2)	0.19(4.8)	0.56(14.3)	0.94(23.8)	0.93(23.6)
3/8	1/4	-CM-FL6-ONS4	1.57(39.9)	0.38(9.7)	0.66(16.8)	0.28(7.1)	0.69(17.5)	0.94(23.8)	0.93(23.6)
3/8	3/8	-CM-FL6-ONS6	1.63(41.4)	0.41(10.4)	0.66(16.8)	0.28(7.1)	0.69(17.5)	1.13(28.6)	1.12(28.4)
3/8	1/2	-CM-FL6-ONS8	1.85(47.0)	0.53(13.5)	0.66(16.8)	0.28(7.1)	0.69(17.5)	1.31(33.3)	1.30(33.0)
1/2	1/2	-CM-FL8-ONS8	1.96(49.8)	0.53(13.5)	0.90(22.9)	0.41(10.4)	0.87(22.2)	1.31(33.3)	1.30(33.0)

Male Connectors

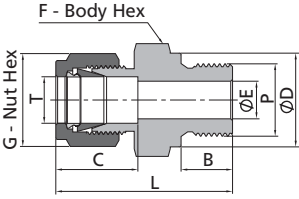

Fractional Tube			Metric Thread (MRS)							
T-Tube O.D. (in.)	P-Metric Thread Size	Basic Ordering Number	Dimensions, in. (mm)							
			L	B	C	E	G	F	D	
1/8	M14 x 1.5	-CM-FL2-MRS14	1.44(36.7)	0.47(12.0)	0.50(12.7)	0.09(2.3)	0.44(11.1)	0.75(19.1)	0.75(19.0)	
1/8	M16 x 1.5	-CM-FL2-MRS16	1.48(37.5)	0.47(12.0)	0.50(12.7)	0.09(2.3)	0.44(11.1)	0.87(22.2)	0.83(21.0)	
1/8	M18 x 1.5	-CM-FL2-MRS18	1.52(38.5)	0.47(12.0)	0.50(12.7)	0.09(2.3)	0.44(11.1)	0.94(23.8)	0.91(23.0)	
1/8	M20 x 1.5	-CM-FL2-MRS20	1.62(41.1)	0.55(14.0)	0.50(12.7)	0.09(2.3)	0.44(11.1)	1.00(25.4)	0.98(25.0)	
1/4	M14 x 1.5	-CM-FL4-MRS14	1.50(38.0)	0.47(12.0)	0.60(15.2)	0.19(4.8)	0.56(14.3)	0.75(19.1)	0.75(19.0)	
1/4	M16 x 1.5	-CM-FL4-MRS16	1.57(39.9)	0.47(12.0)	0.60(15.2)	0.19(4.8)	0.56(14.3)	0.87(22.2)	0.83(21.0)	
1/4	M18 x 1.5	-CM-FL4-MRS18	1.61(40.8)	0.47(12.0)	0.60(15.2)	0.19(4.8)	0.56(14.3)	0.94(23.8)	0.91(23.0)	
1/4	M20 x 1.5	-CM-FL4-MRS20	1.72(43.6)	0.55(14.0)	0.60(15.2)	0.19(4.8)	0.56(14.3)	1.00(25.4)	0.98(25.0)	
3/8	M14 x 1.5	-CM-FL6-MRS14	1.63(41.3)	0.47(12.0)	0.66(16.8)	0.28(7.1)	0.69(17.5)	0.75(19.1)	0.75(19.0)	
3/8	M16 x 1.5	-CM-FL6-MRS16	1.63(41.3)	0.47(12.0)	0.66(16.8)	0.28(7.1)	0.69(17.5)	0.87(22.2)	0.83(21.0)	
3/8	M18 x 1.5	-CM-FL6-MRS18	1.65(41.8)	0.47(12.0)	0.66(16.8)	0.28(7.1)	0.69(17.5)	0.94(23.8)	0.91(23.0)	
3/8	M20 x 1.5	-CM-FL6-MRS20	1.78(45.1)	0.55(14.0)	0.66(16.8)	0.28(7.1)	0.69(17.5)	1.00(25.4)	0.98(25.0)	
1/2	M16 x 1.5	-CM-FL8-MRS16	1.73(44.0)	0.47(12.0)	0.90(22.8)	0.35(9.0)	0.87(22.2)	0.87(22.2)	0.83(21.0)	
1/2	M18 x 1.5	-CM-FL8-MRS18	1.73(44.0)	0.47(12.0)	0.90(22.9)	0.39(10.0)	0.87(22.2)	0.94(23.8)	0.91(23.0)	
1/2	M20 x 1.5	-CM-FL8-MRS20	1.89(47.9)	0.55(14.0)	0.90(22.9)	0.41(10.4)	0.87(22.2)	1.00(25.4)	0.98(25.0)	
1/2	M22 x 1.5	-CM-FL8-MRS22	1.91(48.5)	0.55(14.0)	0.90(22.9)	0.41(10.4)	0.87(22.2)	1.06(27.0)	1.06(27.0)	

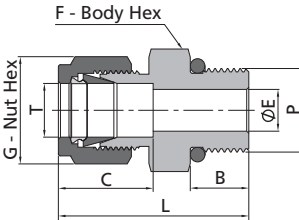

Adapt to straight thread boss of ISO 6149-1.

Fractional Tube			Metric Thread (MST)					
T-Tube O.D. (in.)	P-Metric Thread Size	Basic Ordering Number	Dimensions, in. (mm)					
			L	B	C	E	G	F
1/4	M14X1.5	-CM-FL4-MST14	1.39(35.2)	0.43(11.0)	0.60(15.2)	0.19(4.8)	0.56(14.3)	0.75(19.1)
3/8	M14X1.5	-CM-FL6-MST14	1.44(36.7)	0.43(11.0)	0.66(16.8)	0.28(7.1)	0.69(17.5)	0.75(19.1)
3/8	M20X1.5	-CM-FL6-MST20	1.62(41.2)	0.55(14.0)	0.66(16.8)	0.28(7.1)	0.69(17.5)	1.06(27.0)
1/2	M14X1.5	-CM-FL8-MST14	1.58(40.2)	0.43(11.0)	0.90(22.9)	0.30(7.5)	0.87(22.2)	0.81(20.6)
1/2	M20X1.5	-CM-FL8-MST20	1.73(44.0)	0.55(14.0)	0.90(22.9)	0.41(10.4)	0.87(22.2)	1.06(27.0)

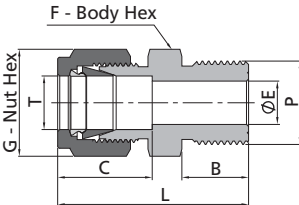

Fractional Tube			Metric Thread (MS)					
T-Tube O.D. (in.)	P-Metric Thread Size	Basic Ordering Number	Dimensions, in. (mm)					
			L	B	C	E	G	F
1/16	M5 x 0.8	-CM-FL1-MS5	0.86(21.8)	0.31(8.0)	0.34(8.6)	0.05(1.3)	0.31(7.9)	0.31(7.9)
1/8	M14 x 1.5	-CM-FL2-MS14	1.37(34.8)	0.51(13.0)	0.50(12.7)	0.09(2.3)	0.44(11.1)	0.63(15.9)
1/8	M16 x 1.5	-CM-FL2-MS16	1.41(35.8)	0.55(14.0)	0.50(12.7)	0.09(2.3)	0.44(11.1)	0.69(17.5)
1/8	M18 x 1.5	-CM-FL2-MS18	1.46(37.2)	0.59(15.0)	0.50(12.7)	0.09(2.3)	0.44(11.1)	0.75(19.1)
1/8	M20 x 1.5	-CM-FL2-MS20	1.50(38.1)	0.63(16.0)	0.50(12.7)	0.09(2.3)	0.44(11.1)	0.87(22.2)
1/4	M14 x 1.5	-CM-FL4-MS14	1.45(36.9)	0.51(13.0)	0.60(15.2)	0.19(4.8)	0.56(14.3)	0.63(15.9)
1/4	M16 x 1.5	-CM-FL4-MS16	1.50(38.1)	0.55(14.0)	0.60(15.2)	0.19(4.8)	0.56(14.3)	0.69(17.5)
1/4	M18 x 1.5	-CM-FL4-MS18	1.56(39.5)	0.59(15.0)	0.60(15.2)	0.19(4.8)	0.56(14.3)	0.75(19.1)
1/4	M20 x 1.5	-CM-FL4-MS20	1.60(40.7)	0.63(16.0)	0.60(15.2)	0.19(4.8)	0.56(14.3)	0.87(22.2)
3/8	M10 x 1.0	-CM-FL6-MS10	1.43(36.4)	0.43(11.0)	0.66(16.8)	0.19(4.8)	0.69(17.5)	0.63(15.9)
3/8	M14 x 1.5	-CM-FL6-MS14	1.55(39.3)	0.51(13.0)	0.66(16.8)	0.28(7.1)	0.69(17.5)	0.63(15.9)
3/8	M16 x 1.5	-CM-FL6-MS16	1.56(39.7)	0.55(14.0)	0.66(16.8)	0.28(7.1)	0.69(17.5)	0.69(17.5)
3/8	M18 x 1.5	-CM-FL6-MS18	1.63(41.5)	0.59(15.0)	0.66(16.8)	0.28(7.1)	0.69(17.5)	0.75(19.1)
3/8	M20 x 1.5	-CM-FL6-MS20	1.67(42.3)	0.63(16.0)	0.66(16.8)	0.28(7.1)	0.69(17.5)	0.87(22.2)
1/2	M16 x 1.5	-CM-FL8-MS16	1.70(43.2)	0.55(14.0)	0.90(22.9)	0.33(8.4)	0.87(22.2)	0.81(20.6)
1/2	M18 x 1.5	-CM-FL8-MS18	1.72(43.7)	0.59(15.0)	0.90(22.9)	0.38(9.6)	0.87(22.2)	0.81(20.6)
1/2	M20 x 1.5	-CM-FL8-MS20	1.77(44.9)	0.63(16.0)	0.90(22.9)	0.41(10.4)	0.87(22.2)	0.87(22.2)
1/2	M22 x 1.5	-CM-FL8-MS22	1.85(47.0)	0.67(17.0)	0.90(22.9)	0.41(10.4)	0.87(22.2)	0.94(23.8)

A-18 6 Series Tube Fittings

Male Connectors

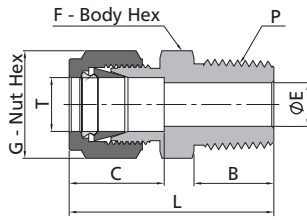

Metric Tube			NPT Thread					
T-Tube O.D. (mm)	P-NPT Size	Basic Ordering Number	Dimensions, mm (in.)					
			L	B	C	E	G	F
2	1/8	-CM-ML2-NS2	30.5(1.20)	9.7(0.38)	12.9(0.51)	1.7(0.07)	12.0(0.47)	12.0(0.47)
3	1/8	-CM-ML3-NS2	30.5(1.20)	9.7(0.38)	12.9(0.51)	2.4(0.09)	12.0(0.47)	12.0(0.47)
3	1/4	-CM-ML3-NS4	35.6(1.40)	14.2(0.56)	12.9(0.51)	2.4(0.09)	12.0(0.47)	14.0(0.55)
4	1/8	-CM-ML4-NS2	31.2(1.23)	9.7(0.38)	13.7(0.54)	2.4(0.09)	12.0(0.47)	12.0(0.47)
4	1/4	-CM-ML4-NS4	36.3(1.43)	14.2(0.56)	13.7(0.54)	2.4(0.09)	12.0(0.47)	14.0(0.55)
6	1/8	-CM-ML6-NS2	32.8(1.29)	9.7(0.38)	15.3(0.60)	4.8(0.19)	14.0(0.55)	14.0(0.55)
6	1/4	-CM-ML6-NS4	37.9(1.49)	14.2(0.56)	15.3(0.60)	4.8(0.19)	14.0(0.55)	14.0(0.55)
6	3/8	-CM-ML6-NS6	38.4(1.51)	14.2(0.56)	15.3(0.60)	4.8(0.19)	14.0(0.55)	18.0(0.71)
6	1/2	-CM-ML6-NS8	44.7(1.76)	19.1(0.75)	15.3(0.60)	4.8(0.19)	14.0(0.55)	22.0(0.87)
8	1/8	-CM-ML8-NS2	34.2(1.35)	9.7(0.38)	16.2(0.64)	4.8(0.19)	16.0(0.63)	15.0(0.59)
8	1/4	-CM-ML8-NS4	38.7(1.52)	14.2(0.56)	16.2(0.64)	6.4(0.25)	16.0(0.63)	15.0(0.59)
8	3/8	-CM-ML8-NS6	39.3(1.55)	14.2(0.56)	16.2(0.64)	6.4(0.25)	16.0(0.63)	18.0(0.71)
8	1/2	-CM-ML8-NS8	45.6(1.80)	19.1(0.75)	16.2(0.64)	6.4(0.25)	16.0(0.63)	22.0(0.87)
10	1/8	-CM-ML10-NS2	36.3(1.43)	9.7(0.38)	17.2(0.68)	4.8(0.19)	19.0(0.75)	18.0(0.71)
10	1/4	-CM-ML10-NS4	40.9(1.61)	14.2(0.56)	17.2(0.68)	7.1(0.28)	19.0(0.75)	18.0(0.71)
10	3/8	-CM-ML10-NS6	40.9(1.61)	14.2(0.56)	17.2(0.68)	7.9(0.31)	19.0(0.75)	18.0(0.71)
10	1/2	-CM-ML10-NS8	46.5(1.83)	19.1(0.75)	17.2(0.68)	7.9(0.31)	19.0(0.75)	22.0(0.87)
10	3/4	-CM-ML10-NS12	48.0(1.89)	19.1(0.75)	17.2(0.68)	7.9(0.31)	19.0(0.75)	27.0(1.06)
10	1	-CM-ML10-NS16	54.6(2.15)	23.9(0.94)	17.2(0.68)	7.9(0.31)	19.0(0.75)	35.0(1.38)
12	1/8	-CM-ML12-NS2	38.8(1.53)	9.7(0.38)	22.8(0.90)	4.8(0.19)	22.0(0.87)	22.0(0.87)
12	1/4	-CM-ML12-NS4	43.4(1.71)	14.2(0.56)	22.8(0.90)	7.1(0.28)	22.0(0.87)	22.0(0.87)
12	3/8	-CM-ML12-NS6	43.4(1.71)	14.2(0.56)	22.8(0.90)	9.5(0.37)	22.0(0.87)	22.0(0.87)
12	1/2	-CM-ML12-NS8	49.0(1.93)	19.1(0.75)	22.8(0.90)	9.5(0.37)	22.0(0.87)	22.0(0.87)
12	3/4	-CM-ML12-NS12	49.1(1.93)	19.1(0.75)	22.8(0.90)	9.5(0.37)	22.0(0.87)	27.0(1.06)
14	1/8	-CM-ML14-NS2	39.9(1.57)	9.7(0.38)	24.4(0.96)	4.8(0.19)	25.0(0.98)	24.0(0.94)
14	1/4	-CM-ML14-NS4	44.1(1.74)	14.2(0.56)	24.4(0.96)	7.1(0.28)	25.0(0.98)	24.0(0.94)
14	3/8	-CM-ML14-NS6	44.1(1.74)	14.2(0.56)	24.4(0.96)	9.5(0.37)	25.0(0.98)	24.0(0.94)
14	1/2	-CM-ML14-NS8	49.0(1.93)	19.1(0.75)	24.4(0.96)	11.1(0.44)	25.0(0.98)	24.0(0.94)
14	3/4	-CM-ML14-NS12	49.1(1.93)	19.1(0.75)	24.4(0.96)	11.1(0.44)	25.0(0.98)	27.0(1.06)
15	1/2	-CM-ML15-NS8	49.0(1.93)	19.1(0.75)	24.4(0.96)	11.9(0.47)	25.0(0.98)	24.0(0.94)
15	3/4	-CM-ML15-NS12	50.5(1.99)	19.1(0.75)	24.4(0.96)	11.9(0.47)	25.0(0.98)	27.0(1.06)
15	1	-CM-ML15-NS16	57.1(2.25)	23.9(0.94)	24.4(0.96)	11.9(0.47)	25.0(0.98)	35.0(1.38)
16	1/4	-CM-ML16-NS4	44.1(1.74)	14.2(0.56)	24.4(0.96)	7.1(0.28)	25.0(0.98)	24.0(0.94)
16	3/8	-CM-ML16-NS6	44.1(1.74)	14.2(0.56)	24.4(0.96)	9.5(0.37)	25.0(0.98)	24.0(0.94)
16	1/2	-CM-ML16-NS8	49.0(1.93)	19.1(0.75)	24.4(0.96)	11.9(0.47)	25.0(0.98)	24.0(0.94)
16	3/4	-CM-ML16-NS12	50.5(1.99)	19.1(0.75)	24.4(0.96)	12.7(0.5)	25.0(0.98)	27.0(1.06)
18	3/8	-CM-ML18-NS6	45.6(1.80)	14.2(0.56)	24.4(0.96)	9.5(0.37)	30.0(1.18)	27.0(1.06)
18	1/2	-CM-ML18-NS8	50.5(1.99)	19.1(0.75)	24.4(0.96)	11.9(0.47)	30.0(1.18)	27.0(1.06)
18	3/4	-CM-ML18-NS12	50.5(1.99)	19.1(0.75)	24.4(0.96)	15.1(0.59)	30.0(1.18)	27.0(1.06)
20	1/2	-CM-ML20-NS8	52.3(2.06)	19.1(0.75)	26.0(1.02)	11.9(0.47)	32.0(1.26)	30.0(1.18)
20	3/4	-CM-ML20-NS12	52.3(2.06)	19.1(0.75)	26.0(1.02)	15.9(0.63)	32.0(1.26)	30.0(1.18)
20	1	-CM-ML20-NS16	57.1(2.25)	23.9(0.94)	26.0(1.02)	15.9(0.63)	32.0(1.26)	35.0(1.38)
22	1/2	-CM-ML22-NS8	52.3(2.06)	19.1(0.75)	26.0(1.02)	11.9(0.47)	32.0(1.26)	30.0(1.18)
22	3/4	-CM-ML22-NS12	52.3(2.06)	19.1(0.75)	26.0(1.02)	15.9(0.63)	32.0(1.26)	30.0(1.18)
22	1	-CM-ML22-NS16	57.1(2.25)	23.9(0.94)	26.0(1.02)	18.3(0.72)	32.0(1.26)	35.0(1.38)
25	1/2	-CM-ML25-NS8	57.5(2.26)	19.1(0.75)	31.3(1.23)	11.9(0.47)	38.0(1.50)	35.0(1.38)
25	3/4	-CM-ML25-NS12	57.5(2.26)	19.1(0.75)	31.3(1.23)	15.9(0.63)	38.0(1.50)	35.0(1.38)
25	1	-CM-ML25-NS16	62.3(2.45)	23.9(0.94)	31.3(1.23)	21.8(0.86)	38.0(1.50)	35.0(1.38)
28	1	-CM-ML28-NS16	72.4(2.85)	23.9(0.94)	36.6(1.44)	21.8(0.86)	46.0(1.81)	41.0(1.61)
28	1 1/4	-CM-ML28-NS20	73.1(2.88)	23.9(0.94)	36.6(1.44)	21.8(0.86)	46.0(1.81)	46.0(1.81)
30	1 1/4	-CM-ML30-NS20	77.2(3.04)	23.9(0.94)	39.6(1.56)	26.2(1.03)	50.0(1.97)	46.0(1.81)
32	1 1/4	-CM-ML32-NS20	79.6(3.13)	23.9(0.94)	42.0(1.65)	28.6(1.13)	50.0(1.97)	46.0(1.81)
38	1 1/2	-CM-ML38-NS24	91.6(3.61)	26.2(1.03)	49.4(1.94)	33.7(1.33)	60.0(2.36)	55.0(2.17)

Male Connectors

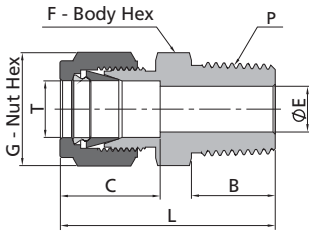

Metric Tube			ISO Tapered Thread (RT)					
T-Tube O.D. (mm)	P-RT Size	Basic Ordering Number	Dimensions, mm (in.)					
			L	B	C	E	G	F
2	1/8	-CM-ML2-RT2	30.5(1.20)	9.7(0.38)	12.9(0.51)	1.7(0.07)	12.0(0.47)	12.0(0.47)
3	1/8	-CM-ML3-RT2	30.5(1.20)	9.7(0.38)	12.9(0.51)	2.4(0.09)	12.0(0.47)	12.0(0.47)
3	1/4	-CM-ML3-RT4	35.6(1.40)	14.2(0.56)	12.9(0.51)	2.4(0.09)	12.0(0.47)	14.0(0.55)
4	1/8	-CM-ML4-RT2	31.2(1.23)	9.7(0.38)	13.7(0.54)	2.4(0.09)	12.0(0.47)	12.0(0.47)
4	1/4	-CM-ML4-RT4	36.3(1.43)	14.2(0.56)	13.7(0.54)	2.4(0.09)	12.0(0.47)	14.0(0.55)
6	1/8	-CM-ML6-RT2	32.8(1.29)	9.7(0.38)	15.3(0.60)	4.8(0.19)	14.0(0.55)	14.0(0.55)
6	1/4	-CM-ML6-RT4	37.9(1.49)	14.2(0.56)	15.3(0.60)	4.8(0.19)	14.0(0.55)	14.0(0.55)
6	3/8	-CM-ML6-RT6	38.4(1.51)	14.2(0.56)	15.3(0.60)	4.8(0.19)	14.0(0.55)	18.0(0.71)
6	1/2	-CM-ML6-RT8	44.7(1.76)	19.1(0.75)	15.3(0.60)	4.8(0.19)	14.0(0.55)	22.0(0.87)
8	1/8	-CM-ML8-RT2	34.2(1.35)	9.7(0.38)	16.2(0.64)	4.8(0.19)	16.0(0.63)	15.0(0.59)
8	1/4	-CM-ML8-RT4	38.7(1.52)	14.2(0.56)	16.2(0.64)	6.4(0.25)	16.0(0.63)	15.0(0.59)
8	3/8	-CM-ML8-RT6	39.2(1.54)	14.2(0.56)	16.2(0.64)	6.4(0.25)	16.0(0.63)	18.0(0.71)
8	1/2	-CM-ML8-RT8	45.6(1.80)	19.1(0.75)	16.2(0.64)	6.4(0.25)	16.0(0.63)	22.0(0.87)
10	1/8	-CM-ML10-RT2	36.3(1.43)	9.7(0.38)	17.2(0.68)	4.8(0.19)	19.0(0.75)	18.0(0.71)
10	1/4	-CM-ML10-RT4	40.9(1.61)	14.2(0.56)	17.2(0.68)	7.1(0.28)	19.0(0.75)	18.0(0.71)
10	3/8	-CM-ML10-RT6	40.9(1.61)	14.2(0.56)	17.2(0.68)	7.9(0.31)	19.0(0.75)	18.0(0.71)
10	1/2	-CM-ML10-RT8	46.5(1.83)	19.1(0.75)	17.2(0.68)	7.9(0.31)	19.0(0.75)	22.0(0.87)
10	3/4	-CM-ML10-RT12	48.0(1.89)	19.1(0.75)	17.2(0.68)	7.9(0.31)	19.0(0.75)	27.0(1.06)
12	1/8	-CM-ML12-RT2	38.9(1.53)	9.7(0.38)	22.8(0.90)	4.8(0.19)	22.0(0.87)	22.0(0.87)
12	1/4	-CM-ML12-RT4	43.4(1.71)	14.2(0.56)	22.8(0.90)	7.1(0.28)	22.0(0.87)	22.0(0.87)
12	3/8	-CM-ML12-RT6	43.4(1.71)	14.2(0.56)	22.8(0.90)	9.5(0.37)	22.0(0.87)	22.0(0.87)
12	1/2	-CM-ML12-RT8	49.0(1.93)	19.1(0.75)	22.8(0.90)	9.5(0.37)	22.0(0.87)	22.0(0.87)
12	3/4	-CM-ML12-RT12	50.5(1.99)	19.1(0.75)	22.8(0.90)	9.5(0.37)	22.0(0.87)	27.0(1.06)
14	1/8	-CM-ML14-RT2	39.9(1.57)	9.7(0.38)	24.4(0.96)	4.8(0.19)	25.0(0.98)	24.0(0.94)
14	1/4	-CM-ML14-RT4	44.1(1.74)	14.2(0.56)	24.4(0.96)	7.1(0.28)	25.0(0.98)	24.0(0.94)
14	3/8	-CM-ML14-RT6	44.1(1.74)	14.2(0.56)	24.4(0.96)	9.5(0.37)	25.0(0.98)	24.0(0.94)
14	1/2	-CM-ML14-RT8	49.0(1.93)	19.1(0.75)	24.4(0.96)	11.1(0.44)	25.0(0.98)	24.0(0.94)
14	3/4	-CM-ML14-RT12	50.5(1.99)	19.1(0.75)	24.4(0.96)	11.1(0.44)	25.0(0.98)	27.0(1.06)
15	1/2	-CM-ML15-RT8	49.0(1.93)	19.1(0.75)	24.4(0.96)	11.9(0.47)	25.0(0.98)	24.0(0.94)
16	1/4	-CM-ML16-RT4	44.1(1.74)	14.2(0.56)	24.4(0.96)	7.1(0.28)	25.0(0.98)	24.0(0.94)
16	3/8	-CM-ML16-RT6	44.1(1.74)	14.2(0.56)	24.4(0.96)	9.5(0.37)	25.0(0.98)	24.0(0.94)
16	1/2	-CM-ML16-RT8	49.0(1.93)	19.1(0.75)	24.4(0.96)	11.9(0.47)	25.0(0.98)	24.0(0.94)
16	3/4	-CM-ML16-RT12	50.5(1.99)	19.1(0.75)	24.4(0.96)	12.7(0.5)	25.0(0.98)	27.0(1.06)
18	1/2	-CM-ML18-RT8	50.5(1.99)	19.1(0.75)	24.4(0.96)	11.9(0.47)	30.0(1.18)	27.0(1.06)
18	3/4	-CM-ML18-RT12	50.5(1.99)	19.1(0.75)	24.4(0.96)	15.1(0.59)	30.0(1.18)	27.0(1.06)
20	1/2	-CM-ML20-RT8	52.3(2.06)	19.1(0.75)	26.0(1.02)	11.9(0.47)	32.0(1.26)	30.0(1.18)
20	3/4	-CM-ML20-RT12	52.3(2.06)	19.1(0.75)	26.0(1.02)	15.9(0.63)	32.0(1.26)	30.0(1.18)
22	3/4	-CM-ML22-RT12	52.3(2.06)	19.1(0.75)	26.0(1.02)	15.9(0.63)	32.0(1.26)	30.0(1.18)
22	1	-CM-ML22-RT16	57.1(2.25)	23.9(0.94)	26.0(1.02)	18.3(0.72)	32.0(1.26)	35.0(1.38)
25	1/2	-CM-ML25-RT8	57.5(2.26)	19.1(0.75)	31.3(1.23)	11.9(0.47)	38.0(1.50)	35.0(1.38)
25	3/4	-CM-ML25-RT12	57.5(2.26)	19.1(0.75)	31.3(1.23)	15.9(0.63)	38.0(1.50)	35.0(1.38)
25	1	-CM-ML25-RT16	62.3(2.45)	23.9(0.94)	31.3(1.23)	21.8(0.86)	38.0(1.50)	35.0(1.38)
28	1	-CM-ML28-RT16	72.4(2.85)	23.9(0.94)	36.6(1.44)	21.8(0.86)	46.0(1.81)	41.0(1.61)
28	1 1/4	-CM-ML28-RT20	73.1(2.88)	23.9(0.94)	36.6(1.44)	21.8(0.86)	46.0(1.81)	46.0(1.81)
30	1 1/4	-CM-ML30-RT20	77.2(3.04)	23.9(0.94)	39.6(1.56)	26.2(1.03)	50.0(1.97)	46.0(1.81)
32	1 1/4	-CM-ML32-RT20	79.6(3.13)	23.9(0.94)	42.0(1.65)	28.6(1.13)	50.0(1.97)	46.0(1.81)
38	1 1/2	-CM-ML38-RT24	91.6(3.61)	26.2(1.03)	49.4(1.94)	33.7(1.33)	60.0(2.36)	55.0(2.17)

A-20 6 Series Tube Fittings

Male Connectors

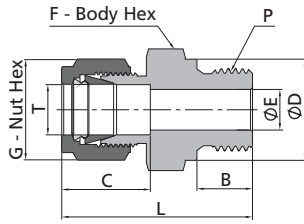

Metric Tube			ISO Parallel Thread (RS)						
T-Tube O.D. (mm)	P-RS Size	Basic Ordering Number	Dimensions, mm (in.)						
			L	B	C	E	G	F	D
2	1/8	-CM-ML2-RS2	30.0(1.18)	7.1(0.28)	12.9(0.51)	1.7(0.07)	12.0(0.47)	14.0(0.55)	13.7(0.54)
3	1/8	-CM-ML3-RS2	30.0(1.18)	7.1(0.28)	12.9(0.51)	2.4(0.09)	12.0(0.47)	14.0(0.55)	13.7(0.54)
3	1/4	-CM-ML3-RS4	35.3(1.39)	11.2(0.44)	12.9(0.51)	2.4(0.09)	12.0(0.47)	19.0(0.75)	18.0(0.71)
4	1/8	-CM-ML4-RS2	30.7(1.21)	7.1(0.28)	13.7(0.54)	2.4(0.09)	12.0(0.47)	14.0(0.55)	13.7(0.54)
4	1/4	-CM-ML4-RS4	36.0(1.42)	11.2(0.44)	13.7(0.54)	2.4(0.09)	12.0(0.47)	19.0(0.75)	18.0(0.71)
6	1/8	-CM-ML6-RS2	32.3(1.27)	7.1(0.28)	15.3(0.60)	4.0(0.16)	14.0(0.55)	14.0(0.55)	13.7(0.54)
6	1/4	-CM-ML6-RS4	37.6(1.48)	11.2(0.44)	15.3(0.60)	4.8(0.19)	14.0(0.55)	19.0(0.75)	18.0(0.71)
6	3/8	-CM-ML6-RS6	38.9(1.53)	11.2(0.44)	15.3(0.60)	4.8(0.19)	14.0(0.55)	22.0(0.87)	21.6(0.85)
6	1/2	-CM-ML6-RS8	44.7(1.76)	14.2(0.56)	15.3(0.60)	4.8(0.19)	14.0(0.55)	27.0(1.06)	25.9(1.02)
8	1/8	-CM-ML8-RS2	33.2(1.31)	7.1(0.28)	16.2(0.64)	4.0(0.16)	16.0(0.63)	15.0(0.59)	13.7(0.54)
8	1/4	-CM-ML8-RS4	38.5(1.52)	11.2(0.44)	16.2(0.64)	6.4(0.25)	16.0(0.63)	19.0(0.75)	18.0(0.71)
8	3/8	-CM-ML8-RS6	39.8(1.57)	11.2(0.44)	16.2(0.64)	6.4(0.25)	16.0(0.63)	22.0(0.87)	21.6(0.85)
8	1/2	-CM-ML8-RS8	45.6(1.80)	14.2(0.56)	16.2(0.64)	6.4(0.25)	16.0(0.63)	27.0(1.06)	25.9(1.02)
8	3/4	-CM-ML8-RS12	49.5(1.95)	15.7(0.62)	16.2(0.64)	6.4(0.25)	16.0(0.63)	35.0(1.38)	32.0(1.26)
10	1/4	-CM-ML10-RS4	39.4(1.55)	11.2(0.44)	17.2(0.68)	5.9(0.23)	19.0(0.75)	19.0(0.75)	18.0(0.71)
10	3/8	-CM-ML10-RS6	40.6(1.60)	11.2(0.44)	17.2(0.68)	7.9(0.31)	19.0(0.75)	22.0(0.87)	21.6(0.85)
10	1/2	-CM-ML10-RS8	46.5(1.83)	14.2(0.56)	17.2(0.68)	7.9(0.31)	19.0(0.75)	27.0(1.06)	25.9(1.02)
12	1/4	-CM-ML12-RS4	42.6(1.68)	11.2(0.44)	22.8(0.90)	5.9(0.23)	22.0(0.87)	22.0(0.87)	18.0(0.71)
12	3/8	-CM-ML12-RS6	43.1(1.70)	11.2(0.44)	22.8(0.90)	7.9(0.31)	22.0(0.87)	22.0(0.87)	21.6(0.85)
12	1/2	-CM-ML12-RS8	49.0(1.93)	14.2(0.56)	22.8(0.90)	9.5(0.37)	22.0(0.87)	27.0(1.06)	25.9(1.02)
12	3/4	-CM-ML12-RS12	52.8(2.08)	15.7(0.62)	22.8(0.90)	9.5(0.37)	22.0(0.87)	35.0(1.38)	32.0(1.26)
14	1/4	-CM-ML14-RS4	44.2(1.74)	11.2(0.44)	24.4(0.96)	6.4(0.25)	25.0(0.98)	24.0(0.94)	18.0(0.71)
14	3/8	-CM-ML14-RS6	43.9(1.73)	11.2(0.44)	24.4(0.96)	7.9(0.31)	25.0(0.98)	24.0(0.94)	21.6(0.85)
14	1/2	-CM-ML14-RS8	49.0(1.93)	14.2(0.56)	24.4(0.96)	11.1(0.44)	25.0(0.98)	27.0(1.06)	25.9(1.02)
14	3/4	-CM-ML14-RS12	52.8(2.08)	15.7(0.62)	24.4(0.96)	11.1(0.44)	25.0(0.98)	35.0(1.38)	32.0(1.26)
15	3/8	-CM-ML15-RS6	43.9(1.73)	11.2(0.44)	24.4(0.96)	7.9(0.31)	25.0(0.98)	24.0(0.94)	21.6(0.85)
15	1/2	-CM-ML15-RS8	49.0(1.93)	14.2(0.56)	24.4(0.96)	11.9(0.47)	25.0(0.98)	27.0(1.06)	25.9(1.02)
15	3/4	-CM-ML15-RS12	52.8(2.08)	15.7(0.62)	24.4(0.96)	11.9(0.47)	25.0(0.98)	35.0(1.38)	32.0(1.26)
16	3/8	-CM-ML16-RS6	43.9(1.73)	11.2(0.44)	24.4(0.96)	7.9(0.31)	25.0(0.98)	24.0(0.94)	21.6(0.85)
16	1/2	-CM-ML16-RS8	49.0(1.93)	14.2(0.56)	24.4(0.96)	11.9(0.47)	25.0(0.98)	27.0(1.06)	25.9(1.02)
16	3/4	-CM-ML16-RS12	52.8(2.08)	15.7(0.62)	24.4(0.96)	12.7(0.5)	25.0(0.98)	35.0(1.38)	32.0(1.26)
18	1/2	-CM-ML18-RS8	49.0(1.93)	14.2(0.56)	24.4(0.96)	11.9(0.47)	30.0(1.18)	27.0(1.06)	25.9(1.02)
18	3/4	-CM-ML18-RS12	52.8(2.08)	15.7(0.62)	24.4(0.96)	15.1(0.59)	30.0(1.18)	35.0(1.38)	32.0(1.26)
20	1/2	-CM-ML20-RS8	50.5(1.99)	14.2(0.56)	26.0(1.02)	11.9(0.47)	32.0(1.26)	30.0(1.18)	25.9(1.02)
20	3/4	-CM-ML20-RS12	52.8(2.08)	15.7(0.62)	26.0(1.02)	15.9(0.63)	32.0(1.26)	35.0(1.38)	32.0(1.26)
22	3/4	-CM-ML22-RS12	52.8(2.08)	15.7(0.62)	26.0(1.02)	15.9(0.63)	32.0(1.26)	35.0(1.38)	32.0(1.26)
22	1	-CM-ML22-RS16	55.3(2.18)	18.3(0.72)	26.0(1.02)	18.3(0.72)	32.0(1.26)	41.0(1.61)	39.1(1.54)
25	3/4	-CM-ML25-RS12	57.5(2.26)	15.7(0.62)	31.3(1.23)	15.9(0.63)	38.0(1.50)	35.0(1.38)	32.0(1.26)
25	1	-CM-ML25-RS16	60.1(2.37)	18.3(0.72)	31.3(1.23)	19.8(0.78)	38.0(1.50)	41.0(1.61)	39.1(1.54)
28	1	-CM-ML28-RS16	70.1(2.76)	18.3(0.72)	36.6(1.44)	19.8(0.78)	46.0(1.81)	41.0(1.61)	39.1(1.54)
28	1 1/4	-CM-ML28-RS20	73.9(2.91)	19.8(0.78)	36.6(1.44)	21.8(0.86)	46.0(1.81)	50.0(1.97)	49.0(1.93)
30	1 1/4	-CM-ML30-RS20	79.2(3.12)	19.8(0.78)	39.6(1.56)	26.2(1.03)	50.0(1.97)	50.0(1.97)	49.0(1.93)
32	1 1/4	-CM-ML32-RS20	78.9(3.11)	19.8(0.78)	42.0(1.65)	28.6(1.13)	50.0(1.97)	50.0(1.97)	49.0(1.93)
38	1 1/2	-CM-ML38-RS24	90.8(3.57)	20.6(0.81)	49.4(1.94)	31.8(1.25)	60.0(2.36)	55.0(2.17)	54.7(2.15)

Male Connectors

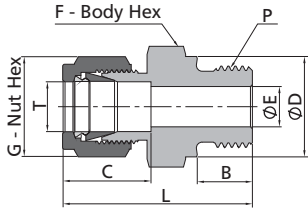

Metric Tube			ISO Parallel Thread (RP)						
T-Tube O.D. (mm)	P-RP Size	Basic Ordering Number	Dimensions, mm (in.)						
			L	B	C	E	G	F	D
3	1/8	-CM-ML3-RP2	30.0(1.18)	7.1(0.28)	12.9(0.51)	2.4(0.09)	12.0(0.47)	14.0(0.55)	13.8(0.54)
3	1/4	-CM-ML3-RP4	35.3(1.39)	11.2(0.44)	12.9(0.51)	2.4(0.09)	12.0(0.47)	19.0(0.75)	18.0(0.71)
4	1/8	-CM-ML4-RP2	30.7(1.21)	7.1(0.28)	13.7(0.54)	2.4(0.09)	12.0(0.47)	14.0(0.55)	13.8(0.54)
6	1/8	-CM-ML6-RP2	32.3(1.27)	7.1(0.28)	15.3(0.60)	4.0(0.16)	14.0(0.55)	14.0(0.55)	13.8(0.54)
6	1/4	-CM-ML6-RP4	37.6(1.48)	11.2(0.44)	15.3(0.60)	4.8(0.19)	14.0(0.55)	19.0(0.75)	18.0(0.71)
6	3/8	-CM-ML6-RP6	38.9(1.53)	11.2(0.44)	15.3(0.60)	4.8(0.19)	14.0(0.55)	22.0(0.87)	21.8(0.86)
6	1/2	-CM-ML6-RP8	44.7(1.76)	14.2(0.56)	15.3(0.60)	4.8(0.19)	14.0(0.55)	27.0(1.06)	26.0(1.02)
8	1/8	-CM-ML8-RP2	33.3(1.31)	7.1(0.28)	16.2(0.64)	4.0(0.16)	16.0(0.63)	15.0(0.59)	13.8(0.54)
8	1/4	-CM-ML8-RP4	38.5(1.52)	11.2(0.44)	16.2(0.64)	5.9(0.23)	16.0(0.63)	19.0(0.75)	18.0(0.71)
8	3/8	-CM-ML8-RP6	39.8(1.57)	11.2(0.44)	16.2(0.64)	6.4(0.25)	16.0(0.63)	22.0(0.87)	21.8(0.86)
8	1/2	-CM-ML8-RP8	45.6(1.80)	14.2(0.56)	16.2(0.64)	6.4(0.25)	16.0(0.63)	27.0(1.06)	26.0(1.02)
10	1/4	-CM-ML10-RP4	39.4(1.55)	11.2(0.44)	17.2(0.68)	5.9(0.23)	19.0(0.75)	19.0(0.75)	18.0(0.71)
10	3/8	-CM-ML10-RP6	42.8(1.69)	11.2(0.44)	17.2(0.68)	7.9(0.31)	19.0(0.75)	22.0(0.87)	21.8(0.86)
10	1/2	-CM-ML10-RP8	46.5(1.83)	14.2(0.56)	17.2(0.68)	7.9(0.31)	19.0(0.75)	27.0(1.06)	26.0(1.02)
12	1/4	-CM-ML12-RP4	42.6(1.68)	11.2(0.44)	22.8(0.90)	5.9(0.23)	22.0(0.87)	22.0(0.87)	18.0(0.71)
12	3/8	-CM-ML12-RP6	43.1(1.70)	11.2(0.44)	22.8(0.90)	7.9(0.31)	22.0(0.87)	22.0(0.87)	21.8(0.86)
12	1/2	-CM-ML12-RP8	52.1(2.05)	14.2(0.56)	22.8(0.90)	9.5(0.37)	22.0(0.87)	27.0(1.06)	26.0(1.02)
12	3/4	-CM-ML12-RP12	52.8(2.08)	15.7(0.62)	22.8(0.90)	9.5(0.37)	22.0(0.87)	35.0(1.38)	32.0(1.26)
15	1/2	-CM-ML15-RP8	47.5(1.87)	14.2(0.56)	24.4(0.96)	11.9(0.47)	25.0(0.98)	27.0(1.06)	26.0(1.02)
16	3/8	-CM-ML16-RP6	43.9(1.73)	11.2(0.44)	24.4(0.96)	7.9(0.31)	25.0(0.98)	24.0(0.94)	21.8(0.86)
16	1/2	-CM-ML16-RP8	49.0(1.93)	14.2(0.56)	24.4(0.96)	11.9(0.47)	25.0(0.98)	27.0(1.06)	26.0(1.02)
18	1/2	-CM-ML18-RP8	49.0(1.93)	14.2(0.56)	24.4(0.96)	11.9(0.47)	30.0(1.18)	27.0(1.06)	26.0(1.02)
18	3/4	-CM-ML18-RP12	52.8(2.08)	15.7(0.62)	24.4(0.96)	15.1(0.59)	30.0(1.18)	35.0(1.38)	32.0(1.26)
20	1/2	-CM-ML20-RP8	50.5(1.99)	14.2(0.56)	26.0(1.02)	11.9(0.47)	32.0(1.26)	30.0(1.18)	26.0(1.02)
20	3/4	-CM-ML20-RP12	52.8(2.08)	15.7(0.62)	26.0(1.02)	15.9(0.63)	32.0(1.26)	35.0(1.38)	32.0(1.26)
22	3/4	-CM-ML22-RP12	52.8(2.08)	15.7(0.62)	26.0(1.02)	15.9(0.63)	32.0(1.26)	35.0(1.38)	32.0(1.26)
22	1	-CM-ML22-RP16	55.3(2.18)	18.3(0.72)	26.0(1.02)	18.3(0.72)	32.0(1.26)	41.0(1.61)	39.0(1.54)
25	3/4	-CM-ML25-RP12	57.5(2.26)	15.7(0.62)	31.3(1.23)	15.9(0.63)	38.0(1.50)	35.0(1.38)	32.0(1.26)
25	1	-CM-ML25-RP16	60.1(2.37)	18.3(0.72)	31.3(1.23)	19.8(0.78)	38.0(1.50)	41.0(1.61)	39.0(1.54)
28	1	-CM-ML28-RP16	70.1(2.76)	18.3(0.72)	36.6(1.44)	19.8(0.78)	46.0(1.81)	41.0(1.61)	39.0(1.54)
28	1 1/4	-CM-ML28-RP20	73.9(2.91)	19.8(0.78)	36.6(1.44)	21.8(0.86)	46.0(1.81)	50.0(1.97)	49.0(1.93)
30	1 1/4	-CM-ML30-RP20	76.5(3.01)	19.8(0.78)	39.6(1.56)	26.2(1.03)	50.0(1.97)	50.0(1.97)	49.0(1.93)
32	1 1/4	-CM-ML32-RP20	78.9(3.11)	19.8(0.78)	42.0(1.65)	28.6(1.13)	50.0(1.97)	50.0(1.97)	49.0(1.93)
38	1 1/2	-CM-ML38-RP24	89.3(3.52)	20.6(0.81)	49.4(1.94)	31.8(1.25)	60.0(2.36)	55.0(2.17)	54.7(2.15)

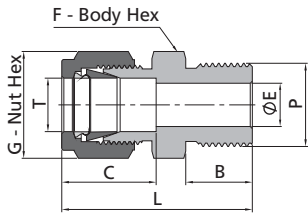

Metric Tube			ISO Parallel Thread (BP)					
T-Tube O.D. (mm)	P-BP Size	Basic Ordering Number	Dimensions, mm (in.)					
			L	B	C	E	G	F
6	1/4	-CM-ML6-BP4	36.9(1.45)	12.9(0.51)	15.3(0.60)	4.8(0.19)	14.0(0.55)	14.0(0.55)
6	3/8	-CM-ML6-BP6	39.5(1.56)	14.2(0.56)	15.3(0.60)	4.8(0.19)	14.0(0.55)	18.0(0.71)
8	1/8	-CM-ML8-BP2	33.9(1.33)	9.8(0.39)	16.2(0.64)	4.0(0.16)	16.0(0.63)	14.0(0.55)
8	1/4	-CM-ML8-BP4	37.0(1.46)	12.9(0.51)	16.2(0.64)	6.4(0.25)	16.0(0.63)	14.0(0.55)
8	3/8	-CM-ML8-BP6	39.3(1.55)	14.2(0.56)	16.2(0.64)	6.4(0.25)	16.0(0.63)	18.0(0.71)
8	1/2	-CM-ML8-BP8	45.4(1.79)	18.8(0.74)	16.2(0.64)	6.4(0.25)	16.0(0.63)	22.0(0.87)
10	1/4	-CM-ML10-BP4	39.5(1.56)	12.9(0.51)	17.2(0.68)	5.9(0.23)	19.0(0.75)	18.0(0.71)
10	1/2	-CM-ML10-BP8	46.3(1.82)	18.8(0.74)	17.2(0.68)	7.9(0.31)	19.0(0.75)	22.0(0.87)
12	3/8	-CM-ML12-BP6	44.2(1.74)	14.2(0.56)	22.8(0.90)	7.9(0.31)	22.0(0.87)	22.0(0.87)
12	1/2	-CM-ML12-BP8	52.1(2.05)	18.8(0.74)	22.8(0.90)	9.5(0.37)	22.0(0.87)	22.0(0.87)
14	1/4	-CM-ML14-BP4	42.9(1.69)	12.9(0.51)	24.4(0.96)	5.9(0.23)	25.0(0.98)	24.0(0.94)
16	3/8	-CM-ML16-BP6	43.4(1.71)	14.2(0.56)	24.4(0.96)	7.9(0.31)	25.0(0.98)	24.0(0.94)
16	1/2	-CM-ML16-BP8	47.9(1.89)	18.8(0.74)	24.4(0.96)	9.5(0.37)	25.0(0.98)	24.0(0.94)
18	1/2	-CM-ML18-BP8	49.8(1.96)	18.8(0.74)	24.4(0.96)	9.5(0.37)	30.0(1.18)	27.0(1.06)

Tube Fittings

A-22 6 Series Tube Fittings

Male Connectors

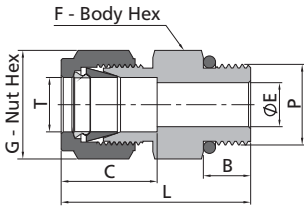

Adapt to straight thread boss of SAE J1926-1, ISO 11926-1 and MS 16142.

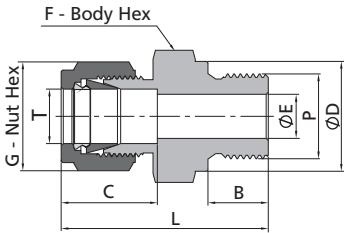

Metric Tube			SAE/MS Straight Thread					
T-Tube O.D. (mm)	P-SAE/MS Thread Size	Basic Ordering Number	Dimensions, mm (in.)					
			L	B	C	E	G	F
6	9/16-18	-CM-ML6-ST9	35.6(1.40)	9.9(0.39)	15.3(0.60)	4.8(0.19)	14.0(0.55)	18.0(0.71)
10	9/16-18	-CM-ML10-ST9	37.3(1.47)	9.9(0.39)	17.2(0.68)	7.1(0.28)	19.0(0.75)	18.0(0.71)
10	3/4-16	-CM-ML10-ST12	39.4(1.55)	11.2(0.44)	17.2(0.68)	7.9(0.31)	19.0(0.75)	22.0(0.87)
12	7/16-20	-CM-ML12-ST7	40.6(1.60)	9.1(0.36)	22.8(0.90)	5.2(0.20)	22.0(0.87)	22.0(0.87)
12	9/16-18	-CM-ML12-ST9	39.9(1.57)	9.9(0.39)	22.8(0.90)	7.1(0.28)	22.0(0.87)	22.0(0.87)

Metric Tube			Metric Thread (MRS)						
T-Tube O.D. (mm)	P-Metric Thread Size	Basic Ordering Number	Dimensions, mm (in.)						
			L	B	C	E	G	F	D
6	M8 x 1	-CM-ML6-MRS8	33.3(1.31)	8.0(0.31)	15.3(0.60)	3.0(0.12)	14.0(0.55)	14.0(0.55)	12.0(0.47)
6	M10 x 1	-CM-ML6-MRS10	33.3(1.31)	8.0(0.31)	15.3(0.60)	4.0(0.16)	14.0(0.55)	14.0(0.55)	14.0(0.55)
6	M12 x 1.5	-CM-ML6-MRS12	38.2(1.50)	12.0(0.47)	15.3(0.60)	4.8(0.19)	14.0(0.55)	18.0(0.71)	17.0(0.67)
6	M14 x 1.5	-CM-ML6-MRS14	39.7(1.56)	12.0(0.47)	15.3(0.60)	4.8(0.19)	14.0(0.55)	22.0(0.87)	19.0(0.75)
8	M8 x 1	-CM-ML8-MRS8	34.1(1.34)	8.0(0.31)	16.2(0.64)	3.0(0.12)	16.0(0.63)	14.0(0.55)	12.0(0.47)
8	M10 x 1	-CM-ML8-MRS10	34.1(1.34)	8.0(0.31)	16.2(0.64)	5.0(0.20)	16.0(0.63)	14.0(0.55)	14.0(0.55)
8	M12 x 1.5	-CM-ML8-MRS12	40.4(1.59)	12.0(0.47)	16.2(0.64)	6.0(0.24)	16.0(0.63)	18.0(0.71)	17.0(0.67)
8	M14 x 1.5	-CM-ML8-MRS14	40.4(1.59)	12.0(0.47)	16.2(0.64)	6.4(0.25)	16.0(0.63)	19.0(0.75)	19.0(0.75)
10	M12 x 1.5	-CM-ML10-MRS12	40.7(1.60)	12.0(0.47)	17.2(0.68)	6.0(0.24)	19.0(0.75)	18.0(0.71)	17.0(0.67)
10	M14 x 1.5	-CM-ML10-MRS14	39.5(1.56)	12.0(0.47)	17.2(0.68)	7.9(0.31)	19.0(0.75)	19.0(0.75)	19.0(0.75)
12	M16 x 1.5	-CM-ML12-MRS16	45.5(1.79)	12.0(0.47)	22.8(0.90)	9.0(0.35)	22.0(0.87)	22.0(0.87)	21.0(0.83)
12	M20 x 1.5	-CM-ML12-MRS20	47.2(1.86)	14.0(0.55)	22.8(0.90)	9.5(0.37)	22.0(0.87)	25.0(0.98)	25.0(0.98)
12	M22 x 1.5	-CM-ML12-MRS22	47.5(1.87)	14.0(0.55)	22.8(0.90)	9.5(0.37)	22.0(0.87)	27.0(1.06)	27.0(1.06)
14	M14 x 1.5	-CM-ML14-MRS14	44.9(1.77)	12.0(0.47)	24.4(0.96)	8.0(0.31)	25.0(0.98)	24.0(0.94)	19.0(0.75)
14	M20 x 1.5	-CM-ML14-MRS20	48.0(1.89)	14.0(0.55)	24.4(0.96)	11.1(0.44)	25.0(0.98)	27.0(1.06)	25.0(0.98)
16	M20 x 1.5	-CM-ML16-MRS20	48.0(1.89)	14.0(0.55)	24.4(0.96)	12.0(0.47)	25.0(0.98)	25.0(0.98)	25.0(0.98)
18	M20 x 1.5	-CM-ML18-MRS20	48.5(1.91)	14.0(0.55)	24.4(0.96)	12.0(0.47)	30.0(1.18)	27.0(1.06)	25.0(0.98)
20	M20 x 1.5	-CM-ML20-MRS20	50.0(1.97)	14.0(0.55)	26.0(1.02)	12.0(0.47)	32.0(1.26)	30.0(1.18)	25.0(0.98)
22	M24 x 1.5	-CM-ML22-MRS24	50.5(1.99)	14.0(0.55)	26.0(1.02)	15.0(0.59)	32.0(1.26)	30.0(1.18)	28.8(1.13)
25	M27 x 2	-CM-ML25-MRS27	57.5(2.26)	16.0(0.63)	31.3(1.23)	16.8(0.66)	38.0(1.50)	35.0(1.38)	32.0(1.26)

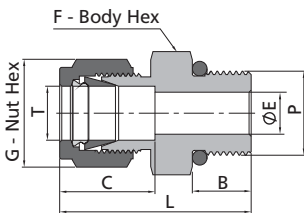

Adapt to straight thread boss of ISO 6149-1.

Metric Tube			Metric Thread (MST)					
T-Tube O.D. (mm)	P-Metric Thread Size	Basic Ordering Number	Dimensions, mm (in.)					
			L	B	C	E	G	F
6	M14 x 1.5	-CM-ML6-MST14	38.7(1.52)	11.0(0.43)	15.3(0.60)	4.8(0.19)	14.0(0.55)	19.0(0.75)
10	M14 x 1.5	-CM-ML10-MST14	40.0(1.57)	11.0(0.43)	17.2(0.68)	7.5(0.30)	19.0(0.75)	19.0(0.75)
10	M20 x 1.5	-CM-ML10-MST20	47.2(1.86)	14.0(0.55)	17.2(0.68)	7.9(0.31)	19.0(0.75)	27.0(1.06)
12	M14 x 1.5	-CM-ML12-MST14	40.2(1.58)	11.0(0.43)	22.8(0.90)	7.5(0.30)	22.0(0.87)	22.0(0.87)
12	M20 x 1.5	-CM-ML12-MST20	47.2(1.86)	14.0(0.55)	22.8(0.90)	9.5(0.37)	22.0(0.87)	27.0(1.06)

Male Connectors

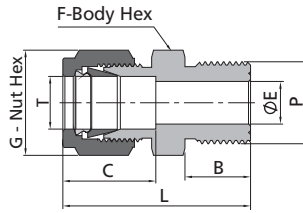

Metric Tube			Metric Thread (MS)					
T-Tube O.D. (mm)	P-Metric Thread Size	Basic Ordering Number	Dimensions, mm (in.)					
			L	B	C	E	G	F
6	M6 x 1	-CM-ML6-MS6	32.4(1.28)	8.0(0.31)	15.3(0.60)	2.0(0.08)	14.0(0.55)	14.0(0.55)
6	M8 x 1	-CM-ML6-MS8	35.3(1.39)	9.0(0.35)	15.3(0.60)	3.0(0.12)	14.0(0.55)	14.0(0.55)
6	M10 x 1	-CM-ML6-MS10	34.7(1.37)	11.0(0.43)	15.3(0.60)	4.7(0.19)	14.0(0.55)	14.0(0.55)
6	M12 x 1.5	-CM-ML6-MS12	36.4(1.43)	12.0(0.47)	15.3(0.60)	4.8(0.19)	14.0(0.55)	14.0(0.55)
6	M14 x 1.5	-CM-ML6-MS14	36.5(1.44)	13.0(0.51)	15.3(0.60)	4.8(0.19)	14.0(0.55)	16.0(0.63)
6	M16 x 1.5	-CM-ML6-MS16	38.4(1.51)	14.0(0.55)	15.3(0.60)	4.8(0.19)	14.0(0.55)	18.0(0.71)
6	M18 x 1.5	-CM-ML6-MS18	40.0(1.57)	15.0(0.59)	15.3(0.60)	4.8(0.19)	14.0(0.55)	19.0(0.75)
6	M20 x 1.5	-CM-ML6-MS20	41.7(1.64)	16.0(0.63)	15.3(0.60)	4.8(0.19)	14.0(0.55)	22.0(0.87)
8	M8 x 1	-CM-ML8-MS8	34.5(1.36)	9.0(0.35)	16.2(0.64)	3.0(0.12)	16.0(0.63)	14.0(0.55)
8	M10 x 1	-CM-ML8-MS10	36.6(1.44)	11.0(0.43)	16.2(0.64)	4.7(0.19)	16.0(0.63)	14.0(0.55)
8	M12 x 1.5	-CM-ML8-MS12	36.6(1.44)	12.0(0.47)	16.2(0.64)	6.0(0.24)	16.0(0.63)	14.0(0.55)
8	M14 x 1.5	-CM-ML8-MS14	37.7(1.48)	13.0(0.51)	16.2(0.64)	6.4(0.25)	16.0(0.63)	16.0(0.63)
8	M20 x 1.5	-CM-ML8-MS20	42.5(1.67)	16.0(0.63)	16.2(0.64)	6.4(0.25)	16.0(0.63)	22.0(0.87)
10	M12 x 1.5	-CM-ML10-MS12	38.7(1.52)	12.0(0.47)	17.2(0.68)	6.0(0.24)	19.0(0.75)	18.0(0.71)
10	M14 x 1.5	-CM-ML10-MS14	39.7(1.56)	13.0(0.51)	17.2(0.68)	7.2(0.28)	19.0(0.75)	18.0(0.71)
10	M20 x 1.5	-CM-ML10-MS20	43.5(1.71)	16.0(0.63)	17.2(0.68)	7.9(0.31)	19.0(0.75)	22.0(0.87)
12	M12 x 1.5	-CM-ML12-MS12	41.2(1.62)	12.0(0.47)	22.8(0.90)	6.0(0.24)	22.0(0.87)	22.0(0.87)
12	M16 x 1.5	-CM-ML12-MS16	43.2(1.70)	14.0(0.55)	22.8(0.90)	8.4(0.33)	22.0(0.87)	22.0(0.87)
12	M18 x 1.5	-CM-ML12-MS18	44.2(1.74)	15.0(0.59)	22.8(0.90)	9.5(0.37)	22.0(0.87)	22.0(0.87)
12	M20 x 1.5	-CM-ML12-MS20	45.2(1.78)	16.0(0.63)	22.8(0.90)	9.5(0.37)	22.0(0.87)	22.0(0.87)
14	M14 x 1.5	-CM-ML14-MS14	42.5(1.67)	13.0(0.51)	24.4(0.96)	7.2(0.28)	25.0(0.98)	24.0(0.94)
14	M16 x 1.5	-CM-ML14-MS16	43.9(1.73)	14.0(0.55)	24.4(0.96)	8.4(0.33)	25.0(0.98)	24.0(0.94)
14	M20 x 1.5	-CM-ML14-MS20	45.1(1.78)	16.0(0.63)	24.4(0.96)	10.8(0.43)	25.0(0.98)	24.0(0.94)
16	M20 x 1.5	-CM-ML16-MS20	46.1(1.81)	16.0(0.63)	24.4(0.96)	10.8(0.43)	25.0(0.98)	24.0(0.94)
18	M20 x 1.5	-CM-ML18-MS20	47.5(1.87)	16.0(0.63)	24.4(0.96)	10.8(0.43)	30.0(1.18)	27.0(1.06)
18	M22 x 1.5	-CM-ML18-MS22	48.5(1.91)	17.0(0.67)	24.4(0.96)	12.0(0.47)	30.0(1.18)	27.0(1.06)
20	M20 x 1.5	-CM-ML20-MS20	49.5(1.95)	16.0(0.63)	26.0(1.02)	10.8(0.43)	32.0(1.26)	30.0(1.18)
22	M24 x 1.5	-CM-ML22-MS24	50.5(1.99)	17.0(0.67)	26.0(1.02)	14.4(0.57)	32.0(1.26)	30.0(1.18)
25	M27 x 2	-CM-ML25-MS27	57.0(2.24)	18.0(0.71)	31.3(1.23)	16.1(0.63)	38.0(1.50)	35.0(1.38)

Bulkhead Male Connectors

Tube Fittings

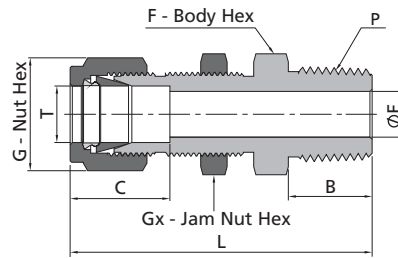

Fractional Tube			Dimensions, in. (mm)								NPT Thread	
T-Tube O.D. (in.)	P-NPT Size	Basic Ordering Number	L	B	C	E	G	F	Gx	Panel Hole Size in. (mm)	Max. Panel Thickness in. (mm)	
1/16	1/16	-BCM-FL1-NS1	1.19(30.2)	0.38(9.7)	0.34(8.6)	0.05(1.3)	0.31(7.9)	0.31(7.9)	0.31(7.9)	0.20(5.2)	0.25(6.4)	
1/16	1/8	-BCM-FL1-NS2	1.27(32.3)	0.38(9.7)	0.34(8.6)	0.05(1.3)	0.31(7.9)	0.44(11.1)	0.31(7.9)	0.20(5.2)	0.25(6.4)	
1/8	1/8	-BCM-FL2-NS2	1.83(46.5)	0.38(9.7)	0.50(12.7)	0.09(2.3)	0.44(11.1)	0.50(12.7)	0.50(12.7)	0.33(8.3)	0.50(12.7)	
3/16	1/8	-BCM-FL3-NS2	1.89(48.0)	0.38(9.7)	0.54(13.7)	0.12(3.0)	0.50(12.7)	0.56(14.3)	0.56(14.3)	0.39(9.9)	0.50(12.7)	
1/4	1/8	-BCM-FL4-NS2	1.95(49.5)	0.38(9.7)	0.60(15.2)	0.19(4.8)	0.56(14.3)	0.63(15.9)	0.63(15.9)	0.45(11.5)	0.40(10.2)	
1/4	1/4	-BCM-FL4-NS4	2.13(54.1)	0.56(14.2)	0.60(15.2)	0.19(4.8)	0.56(14.3)	0.63(15.9)	0.63(15.9)	0.45(11.5)	0.40(10.2)	
1/4	3/8	-BCM-FL4-NS6	2.16(54.9)	0.56(14.2)	0.60(15.2)	0.19(4.8)	0.63(15.9)	0.69(17.5)	0.63(15.9)	0.45(11.5)	0.40(10.2)	
1/4	1/2	-BCM-FL4-NS8	2.37(60.3)	0.75(19.1)	0.60(15.2)	0.19(4.8)	0.56(14.3)	0.87(22.2)	0.63(15.9)	0.45(11.5)	0.40(10.2)	
5/16	1/8	-BCM-FL5-NS2	2.08(52.8)	0.38(9.7)	0.64(16.3)	0.19(4.8)	0.63(15.9)	0.69(17.5)	0.69(17.5)	0.52(13.1)	0.44(11.2)	
5/16	1/4	-BCM-FL5-NS4	2.27(57.7)	0.56(14.2)	0.64(16.3)	0.25(6.4)	0.63(15.9)	0.69(17.5)	0.69(17.5)	0.52(13.1)	0.44(11.2)	
3/8	1/8	-BCM-FL6-NS2	2.08(52.9)	0.38(9.7)	0.66(16.8)	0.19(4.8)	0.69(17.5)	0.75(19.1)	0.75(19.1)	0.58(14.7)	0.44(11.2)	
3/8	1/4	-BCM-FL6-NS4	2.26(57.4)	0.56(14.2)	0.66(16.8)	0.28(7.1)	0.69(17.5)	0.75(19.1)	0.75(19.1)	0.58(14.7)	0.44(11.2)	
3/8	3/8	-BCM-FL6-NS6	2.26(57.4)	0.56(14.2)	0.66(16.8)	0.28(7.1)	0.69(17.5)	0.75(19.1)	0.75(19.1)	0.58(14.7)	0.44(11.2)	
3/8	1/2	-BCM-FL6-NS8	2.51(63.8)	0.75(19.1)	0.66(16.8)	0.28(7.1)	0.69(17.5)	0.87(22.2)	0.87(22.2)	0.58(14.7)	0.44(11.2)	
1/2	1/8	-BCM-FL8-NS2	2.31(58.7)	0.38(9.7)	0.90(22.9)	0.19(4.8)	0.87(22.2)	0.94(23.8)	0.94(23.8)	0.76(19.4)	0.50(12.7)	
1/2	1/4	-BCM-FL8-NS4	2.49(63.2)	0.56(14.2)	0.90(22.9)	0.28(7.1)	0.87(22.2)	0.94(23.8)	0.94(23.8)	0.76(19.4)	0.50(12.7)	
1/2	3/8	-BCM-FL8-NS6	2.49(63.2)	0.56(14.2)	0.90(22.9)	0.38(9.7)	0.87(22.2)	0.94(23.8)	0.87(22.2)	0.76(19.4)	0.50(12.7)	
1/2	1/2	-BCM-FL8-NS8	2.71(68.8)	0.75(19.1)	0.90(22.9)	0.41(10.4)	0.87(22.2)	0.94(23.8)	0.94(23.8)	0.76(19.4)	0.50(12.7)	
5/8	3/8	-BCM-FL10-NS6	2.63(66.7)	0.56(14.2)	0.96(24.4)	0.38(9.7)	1.00(25.4)	1.06(27.0)	1.06(27.0)	0.89(22.6)	0.59(15.1)	
5/8	1/2	-BCM-FL10-NS8	2.81(71.5)	0.75(19.1)	0.96(24.4)	0.47(11.9)	1.00(25.4)	1.06(27.0)	1.06(27.0)	0.89(22.6)	0.59(15.1)	
3/4	1/2	-BCM-FL12-NS8	3.00(76.2)	0.75(19.1)	0.96(24.4)	0.47(11.9)	1.13(28.6)	1.19(30.2)	1.19(30.2)	1.02(25.8)	0.66(16.8)	
3/4	3/4	-BCM-FL12-NS12	3.00(76.2)	0.75(19.1)	0.96(24.4)	0.62(15.7)	1.13(28.6)	1.19(30.2)	1.19(30.2)	1.02(25.8)	0.66(16.8)	
7/8	3/4	-BCM-FL14-NS12	3.31(84.1)	0.75(19.1)	1.02(25.9)	0.62(15.7)	1.25(31.8)	1.31(33.3)	1.31(33.3)	1.14(29.0)	0.75(19.1)	
1	3/4	-BCM-FL16-NS12	3.48(88.4)	0.75(19.1)	1.23(31.2)	0.62(15.7)	1.50(38.1)	1.63(41.3)	1.63(41.3)	1.33(33.7)	0.75(19.1)	
1	1	-BCM-FL16-NS16	3.67(93.2)	0.94(23.9)	1.23(31.2)	0.88(22.4)	1.50(38.1)	1.63(41.3)	1.63(41.3)	1.33(33.7)	0.75(19.1)	

Metric Tube			Dimensions, mm (in.)								NPT Thread	
T-Tube O.D. (mm)	P-NPT Size	Basic Ordering Number	L	B	C	E	G	F	Gx	Panel Hole Size mm (in.)	Max. Panel Thickness mm (in.)	
6	1/8	-BCM-ML6-NS2	49.6(1.95)	9.7(0.38)	15.3(0.60)	4.8(0.19)	14.0(0.55)	16.0(0.63)	16.0(0.63)	11.5(0.45)	10.2(0.40)	
6	1/4	-BCM-ML6-NS4	53.6(2.11)	14.2(0.56)	15.3(0.60)	4.8(0.19)	14.0(0.55)	16.0(0.63)	16.0(0.63)	11.5(0.45)	10.2(0.40)	
8	1/8	-BCM-ML8-NS2	52.3(2.06)	9.7(0.38)	16.2(0.64)	4.8(0.19)	16.0(0.63)	18.0(0.71)	18.0(0.71)	13.1(0.52)	11.2(0.44)	
8	1/4	-BCM-ML8-NS4	56.6(2.23)	14.2(0.56)	16.2(0.64)	6.4(0.25)	16.0(0.63)	18.0(0.71)	18.0(0.71)	13.1(0.52)	11.2(0.44)	
10	1/4	-BCM-ML10-NS4	58.4(2.30)	14.2(0.56)	17.2(0.68)	7.1(0.28)	19.0(0.75)	22.0(0.87)	22.0(0.87)	16.3(0.64)	11.2(0.44)	
10	3/8	-BCM-ML10-NS6	58.4(2.30)	14.2(0.56)	17.2(0.68)	7.9(0.31)	19.0(0.75)	22.0(0.87)	22.0(0.87)	16.3(0.64)	11.2(0.44)	
10	1/2	-BCM-ML10-NS8	63.1(2.48)	19.1(0.75)	17.2(0.68)	7.9(0.31)	19.0(0.75)	22.0(0.87)	22.0(0.87)	16.3(0.64)	11.2(0.44)	
12	1/4	-BCM-ML12-NS4	63.9(2.52)	14.2(0.56)	22.8(0.90)	7.1(0.28)	22.0(0.87)	24.0(0.94)	24.0(0.94)	19.5(0.77)	12.7(0.50)	
12	3/8	-BCM-ML12-NS6	63.9(2.52)	14.2(0.56)	22.8(0.90)	9.5(0.37)	22.0(0.87)	24.0(0.94)	24.0(0.94)	19.5(0.77)	12.7(0.50)	
12	1/2	-BCM-ML12-NS8	68.8(2.71)	19.1(0.75)	22.8(0.90)	9.5(0.37)	22.0(0.87)	24.0(0.94)	24.0(0.94)	19.5(0.77)	12.7(0.50)	

Bulkhead Male Connectors

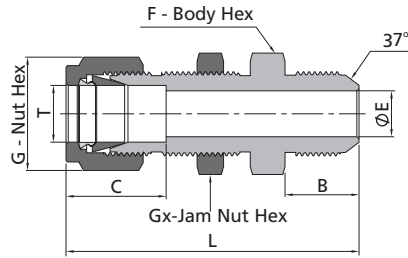

Tube Fittings

Fractional Tube			37° Flare (AN)								
T-Tube O.D. (in.)	AN Tube Flare Size	Basic Ordering Number	Dimensions, in. (mm)							Panel Hole Size in. (mm)	Max. Panel Thickness in. (mm)
			L	B	C	E	G	F	Gx		
1/8	1/8	-BCM-FL2-AN2	1.91(48.5)	0.45(11.4)	0.50(12.7)	0.06(1.5)	0.44(11.1)	0.50(12.7)	0.50(12.7)	0.33(8.3)	0.50(12.7)
1/8	1/4	-BCM-FL2-AN4	2.04(51.8)	0.55(14.0)	0.50(12.7)	0.09(2.3)	0.44(11.1)	0.63(15.9)	0.50(12.7)	0.33(8.3)	0.51(12.7)
3/16	3/16	-BCM-FL3-AN3	1.98(50.3)	0.48(12.2)	0.54(13.7)	0.12(3.0)	0.50(12.7)	0.56(14.3)	0.56(14.3)	0.39(9.9)	0.50(12.7)
1/4	1/4	-BCM-FL4-AN4	2.12(53.8)	0.55(14.0)	0.60(15.2)	0.17(4.3)	0.56(14.3)	0.63(15.9)	0.63(15.9)	0.45(11.5)	0.40(10.2)
5/16	5/16	-BCM-FL5-AN5	2.21(56.1)	0.55(14.0)	0.64(16.2)	0.23(5.8)	0.63(15.9)	0.69(17.5)	0.69(17.5)	0.52(13.1)	0.56(14.3)
3/8	1/4	-BCM-FL6-AN4	2.25(57.2)	0.55(14.0)	0.66(16.8)	0.17(4.3)	0.69(17.5)	0.75(19.1)	0.75(19.1)	0.58(14.7)	0.44(11.2)
3/8	3/8	-BCM-FL6-AN6	2.25(57.2)	0.56(14.2)	0.66(16.8)	0.28(7.1)	0.69(17.5)	0.75(19.1)	0.75(19.1)	0.58(14.7)	0.44(11.2)
1/2	1/2	-BCM-FL8-AN8	2.59(65.8)	0.66(16.8)	0.90(22.8)	0.39(9.9)	0.87(22.2)	0.94(23.8)	0.94(23.8)	0.76(19.4)	0.50(12.7)
5/8	5/8	-BCM-FL10-AN10	2.74(69.6)	0.76(19.3)	0.96(24.4)	0.48(12.3)	1.00(25.4)	1.06(27.0)	1.06(27.0)	0.89(22.6)	0.59(15.1)
3/4	3/4	-BCM-FL12-AN12	3.11(79.0)	0.86(21.8)	0.96(24.4)	0.61(15.5)	1.13(28.6)	1.19(30.2)	1.19(30.2)	1.02(25.8)	0.66(16.8)
1	1	-BCM-FL16-AN16	3.64(92.5)	0.91(23.1)	1.23(31.2)	0.84(21.3)	1.50(38.1)	1.63(41.3)	1.63(41.3)	1.33(33.7)	0.75(19.1)

Thermocouple Connectors

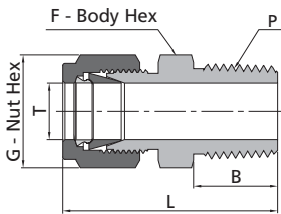

Fractional Tube			NPT Thread			
T-Tube O.D. (in.)	P-NPT Size	Basic Ordering Number	Dimensions, in. (mm)			
			L	B	G	F
1/16	1/16	-TCM-FL1-NS1	0.94(23.9)	0.38(9.7)	0.31(7.9)	0.31(7.9)
1/16	1/8	-TCM-FL1-NS2	1.03(26.2)	0.38(9.7)	0.31(7.9)	0.44(11.1)
1/16	1/4	-TCM-FL1-NS4	1.22(31.0)	0.56(14.2)	0.31(7.9)	0.56(14.3)
1/8	1/16	-TCM-FL2-NS1	1.17(29.7)	0.38(9.7)	0.44(11.1)	0.44(11.1)
1/8	1/8	-TCM-FL2-NS2	1.20(30.5)	0.38(9.7)	0.44(11.1)	0.44(11.1)
1/8	1/4	-TCM-FL2-NS4	1.40(35.6)	0.56(14.2)	0.44(11.1)	0.56(14.3)
3/16	1/8	-TCM-FL3-NS2	1.23(31.2)	0.38(9.7)	0.50(12.7)	0.44(11.1)
3/16	1/4	-TCM-FL3-NS4	1.43(36.3)	0.56(14.2)	0.50(12.7)	0.56(14.3)
1/4	1/8	-TCM-FL4-NS2	1.29(32.8)	0.38(9.7)	0.56(14.3)	0.50(12.7)
1/4	1/4	-TCM-FL4-NS4	1.49(37.8)	0.56(14.2)	0.56(14.3)	0.56(14.3)
1/4	3/8	-TCM-FL4-NS6	1.51(38.4)	0.56(14.2)	0.56(14.3)	0.69(17.5)
1/4	1/2	-TCM-FL4-NS8	1.76(44.7)	0.75(19.1)	0.56(14.3)	0.87(22.2)
5/16	1/4	-TCM-FL5-NS4	1.52(38.6)	0.56(14.2)	0.63(15.9)	0.56(14.3)
3/8	1/4	-TCM-FL6-NS4	1.57(39.9)	0.56(14.2)	0.69(17.5)	0.63(15.9)
3/8	3/8	-TCM-FL6-NS6	1.57(39.9)	0.56(14.2)	0.69(17.5)	0.69(17.5)
3/8	1/2	-TCM-FL6-NS8	1.82(46.2)	0.75(19.1)	0.69(17.5)	0.87(22.2)
3/8	3/4	-TCM-FL6-NS12	1.88(47.8)	0.75(19.1)	0.69(17.5)	1.06(27.0)
1/2	1/2	-TCM-FL8-NS8	1.93(49.0)	0.75(19.1)	0.87(22.2)	0.87(22.2)
1/2	3/4	-TCM-FL8-NS12	1.99(50.5)	0.75(19.1)	0.87(22.2)	1.06(27.0)
5/8	3/4	-TCM-FL10-NS12	1.99(50.5)	0.75(19.1)	1.00(25.4)	1.06(27.0)
3/4	3/4	-TCM-FL12-NS12	1.99(50.5)	0.75(19.1)	1.13(28.6)	1.06(27.0)
1	1	-TCM-FL16-NS16	2.45(62.2)	0.94(23.9)	1.50(38.1)	1.37(34.9)

Thermocouple Connectors

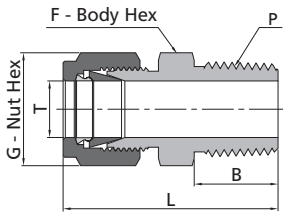

Metric Tube			NPT Thread			
T-Tube O.D. (mm)	P-NPT Size	Basic Ordering Number	Dimensions, mm (in.)			
			L	B	G	F
2	1/8	-TCM-ML2-NS2	30.5(1.20)	9.7(0.38)	12.0(0.47)	12.0(0.47)
3	1/8	-TCM-ML3-NS2	30.5(1.20)	9.7(0.38)	12.0(0.47)	12.0(0.47)
3	1/4	-TCM-ML3-NS4	35.6(1.40)	14.2(0.56)	12.0(0.47)	14.0(0.55)
4	1/8	-TCM-ML4-NS2	31.2(1.23)	9.7(0.38)	12.0(0.47)	12.0(0.47)
4	1/4	-TCM-ML4-NS4	36.3(1.43)	14.2(0.56)	12.0(0.47)	14.0(0.55)
6	1/8	-TCM-ML6-NS2	32.8(1.29)	9.7(0.38)	14.0(0.55)	14.0(0.55)
6	1/4	-TCM-ML6-NS4	37.9(1.49)	14.2(0.56)	14.0(0.55)	14.0(0.55)
6	3/8	-TCM-ML6-NS6	38.4(1.51)	14.2(0.56)	14.0(0.55)	18.0(0.71)
6	1/2	-TCM-ML6-NS8	44.7(1.76)	19.1(0.75)	14.0(0.55)	22.0(0.87)
8	1/4	-TCM-ML8-NS4	38.7(1.52)	14.2(0.56)	16.0(0.63)	15.0(0.59)
8	3/8	-TCM-ML8-NS6	39.3(1.55)	14.2(0.56)	16.0(0.63)	18.0(0.71)
8	1/2	-TCM-ML8-NS8	45.6(1.80)	19.1(0.75)	16.0(0.63)	22.0(0.87)
10	3/8	-TCM-ML10-NS6	40.9(1.61)	14.2(0.56)	19.0(0.75)	18.0(0.71)
10	1/2	-TCM-ML10-NS8	46.5(1.83)	19.1(0.75)	19.0(0.75)	22.0(0.87)
10	3/4	-TCM-ML10-NS12	48.0(1.89)	19.1(0.75)	19.0(0.75)	27.0(1.06)
10	1	-TCM-ML10-NS16	54.6(2.15)	23.9(0.94)	19.0(0.75)	35.0(1.38)
12	3/8	-TCM-ML12-NS6	43.4(1.71)	14.2(0.56)	22.0(0.87)	22.0(0.87)
12	1/2	-TCM-ML12-NS8	49.0(1.93)	19.1(0.75)	22.0(0.87)	22.0(0.87)
12	3/4	-TCM-ML12-NS12	50.5(1.99)	19.1(0.75)	22.0(0.87)	27.0(1.06)
14	1/2	-TCM-ML14-NS8	49.0(1.93)	19.1(0.75)	25.0(0.98)	24.0(0.94)
14	3/4	-TCM-ML14-NS12	50.5(1.99)	19.1(0.75)	25.0(0.98)	27.0(1.06)
15	3/4	-TCM-ML15-NS12	50.5(1.99)	19.1(0.75)	25.0(0.98)	27.0(1.06)
15	1	-TCM-ML15-NS16	57.1(2.25)	23.9(0.94)	25.0(0.98)	35.0(1.38)
18	3/4	-TCM-ML18-NS12	50.5(1.99)	19.1(0.75)	30.0(1.18)	27.0(1.06)
20	1	-TCM-ML20-NS16	57.1(2.25)	23.9(0.94)	32.0(1.26)	35.0(1.38)
22	1	-TCM-ML22-NS16	57.1(2.25)	23.9(0.94)	32.0(1.26)	35.0(1.38)

Chromatograph Fittings

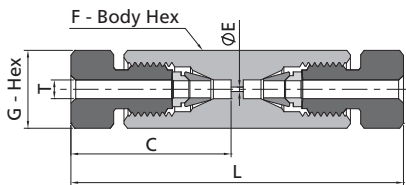

Fractional Tube							
T-Tube O.D (in.)	Basic Ordering Number	Dimensions, in. (mm)					Dead Volume
		L	C	E	G	F	
1/16	-U-NFL1	1.26(32.0)	0.61(15.5)	0.01(0.3)	0.25(6.4)	0.25(6.4)	6.6 × 10 ⁻⁵ cm ³

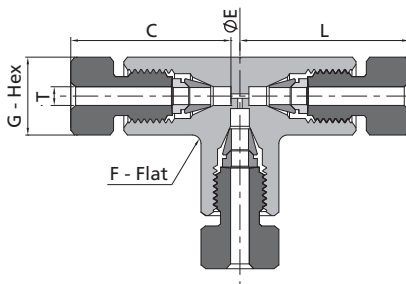

Fractional Tube							
T-Tube O.D (in.)	Basic Ordering Number	Dimensions, in. (mm)					Dead Volume
		L	C	E	G	F	
1/16	-TTT-NFL1	0.66(16.8)	0.61(15.5)	0.01(0.3)	0.25(6.4)	0.37(9.5)	2.8 × 10 ⁻⁴ cm ³

Column End Fittings

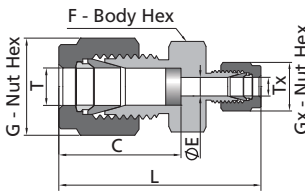
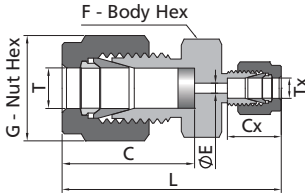
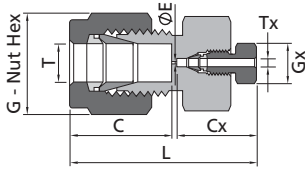

Fractional Tube										
T-Tube O.D. (in.)	Tx-Tube O.D. (in.)	Basic Ordering Number	Dimensions, in. (mm)						Dead Volume	
			L	C	Cx	E	G	Gx		
1/4	1/16	-U-FL4-NFL1	1.24(31.5)	0.60(15.2)	0.61(15.5)	0.01(0.3)	0.56(14.3)	0.25(6.4)	6.8 × 10 ⁻⁵ cm ³	
3/8	1/16	-U-FL6-NFL1	1.30(33.0)	0.66(16.8)	0.61(15.5)	0.01(0.3)	0.69(17.5)	0.25(6.4)	6.8 × 10 ⁻⁵ cm ³	

Fractional Tube										
T-Tube O.D. (in.)	Tx-Tube O.D. (in.)	Basic Ordering Number	Dimensions, in. (mm)						Dead Volume	
			L	C	Cx	G	F	E		
1/8	1/16	-U-TFL2SN7-FL1	1.22(31.0)	0.72(18.3)	0.34(8.6)	0.44(11.1)	0.44(11.1)	0.05(1.3)	5.4 × 10 ⁻³ cm ³	
1/4	1/16	-U-TFL4SN7-FL1	1.35(34.3)	0.82(20.8)	0.34(8.6)	0.56(14.3)	0.50(12.7)	0.05(1.3)	6.7 × 10 ⁻³ cm ³	
3/8	1/16	-U-TFL6SN7-FL1	1.44(36.6)	0.91(23.1)	0.34(8.6)	0.69(17.5)	0.63(15.9)	0.05(1.3)	6.5 × 10 ⁻³ cm ³	

Fractional Tube										
T-Tube O.D. (in.)	Tx-Tube O.D. (in.)	Basic Ordering Number	Dimensions, in. (mm)						Dead Volume	
			L	C	G	Gx	F	E		
1/8	1/16	-U-TFL2SN7-TFL1	1.22(31.0)	0.72(18.3)	0.44(11.1)	0.31(7.9)	0.44(11.1)	0.07(1.7)	0	
1/4	1/16	-U-TFL4SN7-TFL1	1.35(34.3)	0.82(20.8)	0.56(14.3)	0.31(7.9)	0.50(12.7)	0.07(1.7)	0	
3/8	1/16	-U-TFL6SN7-TFL1	1.44(36.6)	0.91(23.1)	0.69(17.5)	0.31(7.9)	0.63(15.9)	0.07(1.7)	0	
1/2	1/16	-U-TFL8SN7-TFL1	1.58(40.1)	1.04(26.4)	0.87(22.2)	0.31(7.9)	0.81(20.6)	0.07(1.7)	0	

Nominal pore size of SN7 Stainless steel sinter is 7 um, and other nominal pore sizes are available. Stainless steel sinters are loosely installed to facilitate removal and replacement.

Female Connectors

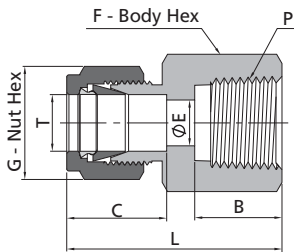

Fractional Tube			NPT Thread						
T-Tube O.D. (in.)	P-NPT Size	Basic Ordering Number	Dimensions, in. (mm)						
			L	B	C	E	G	F	
1/16	1/16	-CF-FL1-NS1	0.93(23.6)	0.39(9.9)	0.34(8.6)	0.05(1.3)	0.31(7.9)	0.44(11.1)	
1/16	1/8	-CF-FL1-NS2	0.96(24.4)	0.41(10.4)	0.34(8.6)	0.05(1.3)	0.31(7.9)	0.56(14.3)	
1/8	1/8	-CF-FL2-NS2	1.13(28.7)	0.41(10.4)	0.50(12.7)	0.09(2.3)	0.44(11.1)	0.56(14.3)	
1/8	1/4	-CF-FL2-NS4	1.32(33.5)	0.59(15.0)	0.50(12.7)	0.09(2.3)	0.44(11.1)	0.75(19.1)	
3/16	1/8	-CF-FL3-NS2	1.17(29.7)	0.41(10.4)	0.54(13.7)	0.12(3.0)	0.50(12.7)	0.56(14.3)	
1/4	1/8	-CF-FL4-NS2	1.23(31.2)	0.41(10.4)	0.60(15.2)	0.19(4.8)	0.56(14.3)	0.56(14.3)	
1/4	1/4	-CF-FL4-NS4	1.41(35.8)	0.59(15.0)	0.60(15.2)	0.19(4.8)	0.56(14.3)	0.75(19.1)	
1/4	3/8	-CF-FL4-NS6	1.48(37.6)	0.59(15.0)	0.60(15.2)	0.19(4.8)	0.56(14.3)	0.87(22.2)	
1/4	1/2	-CF-FL4-NS8	1.67(42.4)	0.78(19.8)	0.60(15.2)	16.3(4.8)	0.56(14.3)	1.06(27.0)	
5/16	1/8	-CF-FL5-NS2	1.26(32.0)	0.41(10.4)	0.64(16.3)	16.3(6.4)	0.63(15.9)	0.56(14.3)	
5/16	1/4	-CF-FL5-NS4	1.45(36.8)	0.59(15.0)	0.64(16.3)	0.25(6.4)	0.63(15.9)	0.75(19.1)	
3/8	1/8	-CF-FL6-NS2	1.29(32.8)	0.41(10.4)	0.66(16.8)	0.28(7.1)	0.69(17.5)	0.63(15.9)	
3/8	1/4	-CF-FL6-NS4	1.48(37.6)	0.59(15.0)	0.66(16.8)	0.28(7.1)	0.69(17.5)	0.75(19.1)	
3/8	3/8	-CF-FL6-NS6	1.54(39.1)	0.59(15.0)	0.66(16.8)	1.34(7.1)	0.69(17.5)	0.88(22.2)	
3/8	1/2	-CF-FL6-NS8	1.73(43.9)	0.78(19.8)	0.66(16.8)	0.28(7.1)	0.69(17.5)	1.06(27.0)	
3/8	3/4	-CF-FL6-NS12	1.88(47.8)	0.81(20.6)	0.66(16.8)	0.28(7.1)	0.69(17.5)	1.31(33.3)	
1/2	1/4	-CF-FL8-NS4	1.59(40.4)	0.59(15.0)	0.90(22.9)	0.41(10.4)	0.87(22.2)	0.81(20.6)	
1/2	3/8	-CF-FL8-NS6	1.65(41.9)	0.59(15.0)	0.90(22.9)	0.41(10.4)	0.87(22.2)	0.87(22.2)	
1/2	1/2	-CF-FL8-NS8	1.84(46.7)	0.78(19.8)	0.90(22.9)	0.41(10.4)	0.87(22.2)	1.06(27.0)	
1/2	3/4	-CF-FL8-NS12	1.90(48.3)	0.81(20.6)	0.90(22.9)	0.41(10.4)	0.87(22.2)	1.31(33.3)	
5/8	3/8	-CF-FL10-NS6	1.65(41.9)	0.59(15.0)	0.96(24.4)	0.50(12.7)	1.00(25.4)	0.94(23.8)	
5/8	1/2	-CF-FL10-NS8	1.84(46.7)	0.78(19.8)	0.96(24.4)	0.50(12.7)	1.00(25.4)	1.06(27.0)	

Female Connectors

Tube Fittings

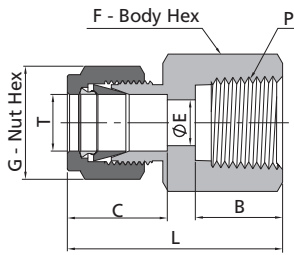

Fractional Tube			NPT Thread						
T-Tube O.D. (in.)	P-NPT Size	Basic Ordering Number	Dimensions, in. (mm)						
			L	B	C	E	G	F	
3/4	1/2	-CF-FL12-NS8	1.84(46.7)	0.78(19.8)	0.96(24.4)	0.62(15.7)	1.13(28.6)	1.06(27.0)	
3/4	3/4	-CF-FL12-NS12	1.90(48.3)	0.81(20.6)	0.96(24.4)	0.62(15.7)	1.13(28.6)	1.31(33.3)	
7/8	3/4	-CF-FL14-NS12	1.96(49.8)	0.81(20.6)	1.02(25.9)	0.72(18.3)	1.25(31.8)	1.31(33.3)	
1	3/4	-CF-FL16-NS12	2.10(53.3)	0.81(20.6)	1.23(31.2)	0.88(22.4)	1.50(38.1)	1.37(34.9)	
1	1	-CF-FL16-NS16	2.45(62.2)	1.00(25.4)	1.23(31.2)	0.88(22.4)	1.50(38.1)	1.63(41.3)	
1 1/4	1 1/4	-CF-FL20-NS20	2.94(74.7)	1.00(25.4)	1.62(41.1)	1.09(27.7)	1.87(47.6)	2.13(54.0)	
1 1/2	1 1/2	-CF-FL24-NS24	3.30(83.8)	1.09(27.7)	1.97(50.0)	1.34(34.0)	2.25(57.2)	2.37(60.3)	

Fractional Tube			ISO Tapered Thread (RT)						
T-Tube O.D. (in.)	P-RT Size	Basic Ordering Number	Dimensions, in. (mm)						
			L	B	C	E	G	F	
1/4	1/8	-CF-FL4-RT2	1.23(31.2)	0.41(10.4)	0.60(15.2)	0.19(4.8)	0.56(14.3)	0.56(14.3)	
1/4	1/4	-CF-FL4-RT4	1.41(35.8)	0.59(15.0)	0.60(15.2)	0.19(4.8)	0.56(14.3)	0.75(19.1)	
1/4	3/8	-CF-FL4-RT6	1.48(37.6)	0.59(15.0)	0.60(15.2)	0.19(4.8)	0.56(14.3)	0.87(22.2)	
1/4	1/2	-CF-FL4-RT8	1.67(42.4)	0.78(19.8)	0.60(15.2)	0.19(4.8)	0.56(14.3)	1.06(27.0)	
3/8	1/4	-CF-FL6-RT4	1.48(37.6)	0.59(15.0)	0.66(16.8)	0.28(7.1)	0.69(17.5)	0.75(19.1)	
3/8	3/8	-CF-FL6-RT6	1.54(39.1)	0.59(15.0)	0.66(16.8)	0.28(7.1)	0.69(17.5)	0.87(22.2)	
3/8	1/2	-CF-FL6-RT8	1.73(43.9)	0.78(19.8)	0.66(16.8)	0.28(7.1)	0.69(17.5)	1.06(27.0)	
1/2	1/4	-CF-FL8-RT4	1.59(40.4)	0.59(15.0)	0.90(22.9)	0.41(10.4)	0.87(22.2)	0.81(20.6)	
1/2	3/8	-CF-FL8-RT6	1.65(41.9)	0.59(15.0)	0.90(22.9)	0.41(10.4)	0.87(22.2)	0.87(22.2)	
1/2	1/2	-CF-FL8-RT8	1.84(46.7)	0.78(19.8)	0.90(22.9)	0.41(10.4)	0.87(22.2)	1.06(27.0)	

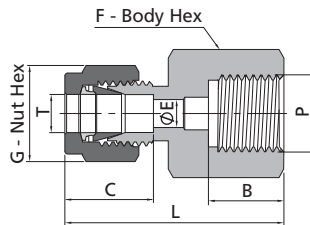

Fractional Tube			ISO Parallel Thread (RG)						
T-Tube O.D. (in.)	P-RG Size	Basic Ordering Number	Dimensions, in. (mm)						
			L	B	C	E	G	F	
1/8	1/4	-CF-FL2-RG4	1.39(35.3)	0.51(12.9)	0.50(12.7)	0.09(2.3)	0.44(11.1)	0.75(19.1)	
1/8	3/8	-CF-FL2-RG6	1.52(38.7)	0.56(14.2)	0.50(12.7)	0.09(2.3)	0.44(11.1)	0.94(23.8)	
1/4	1/4	-CF-FL4-RG4	1.48(37.6)	0.51(12.9)	0.60(15.2)	0.19(4.8)	0.56(14.3)	0.75(19.1)	
1/4	3/8	-CF-FL4-RG6	1.48(37.6)	0.56(14.2)	0.60(15.2)	0.19(4.8)	0.56(14.3)	0.94(23.8)	
1/4	1/2	-CF-FL4-RG8	1.71(43.4)	0.74(18.8)	0.60(15.2)	0.19(4.8)	0.56(14.3)	1.06(27.0)	
5/16	1/4	-CF-FL5-RG4	1.51(38.4)	0.51(12.9)	0.64(16.3)	0.22(5.6)	0.63(15.9)	0.75(19.1)	
5/16	3/8	-CF-FL5-RG6	1.45(36.9)	0.56(14.2)	0.64(16.3)	0.25(6.4)	0.63(15.9)	0.94(23.8)	
5/16	1/2	-CF-FL5-RG8	1.61(40.9)	0.74(18.8)	0.64(16.3)	0.28(7.1)	0.63(15.9)	1.06(27.0)	
3/8	1/4	-CF-FL6-RG4	1.54(39.1)	0.51(12.9)	0.66(16.8)	0.22(5.6)	0.69(17.5)	0.75(19.1)	
3/8	3/8	-CF-FL6-RG6	1.52(38.6)	0.56(14.2)	0.66(16.8)	0.25(6.4)	0.69(17.5)	0.94(23.8)	
3/8	1/2	-CF-FL6-RG8	1.65(41.9)	0.74(18.8)	0.66(16.8)	0.28(7.1)	0.69(17.5)	1.06(27.0)	
1/2	1/4	-CF-FL8-RG4	1.65(41.9)	0.51(12.9)	0.90(22.9)	0.22(5.6)	0.87(22.2)	0.87(22.2)	
1/2	3/8	-CF-FL8-RG6	1.75(44.5)	0.56(14.2)	0.90(22.9)	0.25(6.4)	0.87(22.2)	0.94(23.8)	
1/2	1/2	-CF-FL8-RG8	1.90(48.3)	0.74(18.8)	0.90(22.9)	0.28(7.1)	0.87(22.2)	1.06(27.0)	

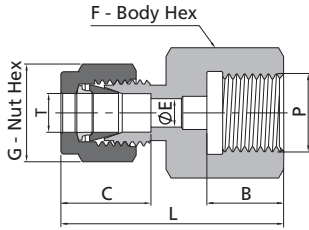

Adapt to Japanese gauge stud (JIS B7505)

Fractional Tube			ISO Parallel Thread (RJ)					
T-Tube O.D. (in.)	P-RJ Size	Basic Ordering Number	Dimensions, in. (mm)					
			L	B	C	E	G	F
1/4	1/4	-CF-FL4-RJ4	1.48(37.6)	0.51(12.9)	0.60(15.2)	0.18(4.6)	0.56(14.3)	0.75(19.1)
1/4	3/8	-CF-FL4-RJ6	1.48(37.6)	0.62(15.8)	0.60(15.2)	0.19(4.8)	0.56(14.3)	0.94(23.8)
1/4	1/2	-CF-FL4-RJ8	1.71(43.4)	0.74(18.8)	0.60(15.2)	0.19(4.8)	0.56(14.3)	1.06(27.0)
5/16	1/4	-CF-FL5-RJ4	1.51(38.4)	0.51(12.9)	0.64(16.3)	0.22(5.6)	0.63(15.9)	0.75(19.1)
5/16	1/2	-CF-FL5-RJ8	1.61(40.9)	0.74(18.8)	0.64(16.3)	0.28(7.1)	0.63(15.9)	1.06(27.0)
3/8	1/4	-CF-FL6-RJ4	1.54(39.1)	0.51(12.9)	0.66(16.8)	0.22(5.6)	0.69(17.5)	0.75(19.1)
3/8	3/8	-CF-FL6-RJ6	1.52(38.6)	0.62(15.8)	0.66(16.8)	0.25(6.4)	0.69(17.5)	0.94(23.8)
3/8	1/2	-CF-FL6-RJ8	1.65(41.9)	0.74(18.8)	0.66(16.8)	0.28(7.1)	0.69(17.5)	1.06(27.0)
1/2	1/4	-CF-FL8-RJ4	1.65(41.9)	0.51(12.9)	0.90(22.9)	0.22(5.6)	0.87(22.2)	0.81(20.6)
1/2	3/8	-CF-FL8-RJ6	1.75(44.5)	0.62(15.8)	0.90(22.9)	0.25(6.4)	0.87(22.2)	0.94(23.8)
1/2	1/2	-CF-FL8-RJ8	1.90(48.3)	0.74(18.8)	0.90(22.9)	0.28(7.1)	0.87(22.2)	1.06(27.0)

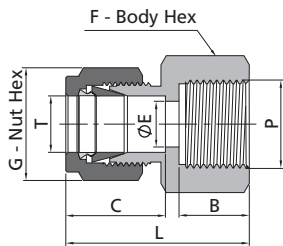

Fractional Tube			Metric Thread					
T-Tube O.D. (in.)	P-Metric Thread Size	Basic Ordering Number	Dimensions, in. (mm)					
			L	B	C	E	G	F
1/8	M14 x 1.5	-CF-FL2-MS14	1.22(31.0)	0.51(13.0)	0.50(12.7)	0.09(2.3)	0.44(11.1)	0.75(19.1)
1/8	M16 x 1.5	-CF-FL2-MS16	1.31(33.3)	0.55(14.0)	0.50(12.7)	0.09(2.3)	0.44(11.1)	0.87(22.2)
1/8	M18 x 1.5	-CF-FL2-MS18	1.35(34.3)	0.59(15.0)	0.50(12.7)	0.09(2.3)	0.44(11.1)	1.00(25.4)
1/8	M20 x 1.5	-CF-FL2-MS20	1.39(35.3)	0.63(16.0)	0.50(12.7)	0.09(2.3)	0.44(11.1)	1.06(27.0)
1/4	M16 x 1.5	-CF-FL4-MS16	1.41(35.8)	0.55(14.0)	0.60(15.2)	0.19(4.8)	0.56(14.3)	0.87(22.2)
1/4	M18 x 1.5	-CF-FL4-MS18	1.45(36.8)	0.59(15.0)	0.60(15.2)	0.19(4.8)	0.56(14.3)	1.00(25.4)
1/4	M20 x 1.5	-CF-FL4-MS20	1.49(37.8)	0.63(16.0)	0.60(15.2)	0.19(4.8)	0.56(14.3)	1.06(27.0)
3/8	M14 x 1.5	-CF-FL6-MS14	1.46(37.1)	0.51(13.0)	0.66(16.8)	0.28(7.1)	0.69(17.5)	0.75(19.1)
3/8	M16 x 1.5	-CF-FL6-MS16	1.48(37.5)	0.55(14.0)	0.66(16.8)	0.28(7.1)	0.69(17.5)	0.87(22.2)
3/8	M18 x 1.5	-CF-FL6-MS18	1.52(38.5)	0.59(15.0)	0.66(16.8)	0.28(7.1)	0.69(17.5)	1.00(25.4)
3/8	M20 x 1.5	-CF-FL6-MS20	1.56(39.5)	0.63(16.0)	0.66(16.8)	0.28(7.1)	0.69(17.5)	1.06(27.0)
1/2	M16 x 1.5	-CF-FL8-MS16	1.63(41.4)	0.55(14.0)	0.90(22.9)	0.33(8.4)	0.87(22.2)	0.87(22.2)
1/2	M18 x 1.5	-CF-FL8-MS18	1.67(42.4)	0.59(15.0)	0.90(22.9)	0.38(9.6)	0.87(22.2)	1.00(25.4)
1/2	M20 x 1.5	-CF-FL8-MS20	1.71(43.4)	0.63(16.0)	0.90(22.9)	0.41(10.4)	0.87(22.2)	1.06(27.0)
1/2	M22 x 1.5	-CF-FL8-MS22	1.65(41.9)	0.63(16.0)	0.90(22.9)	0.38(9.7)	0.87(22.2)	1.06(27.0)

Female Connectors

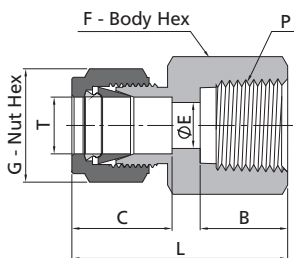

Metric Tube			NPT Thread					
T-Tube O.D. (mm)	P-NPT Size	Basic Ordering Number	Dimensions, mm (in.)					
			L	B	C	E	G	F
3	1/8	-CF-ML3-NS2	28.7(1.13)	10.4(0.41)	12.9(0.51)	2.4(0.09)	12.0(0.47)	14.0(0.55)
3	1/4	-CF-ML3-NS4	33.5(1.32)	15.0(0.59)	12.9(0.51)	2.4(0.09)	12.0(0.47)	19.0(0.75)
4	1/8	-CF-ML4-NS2	29.7(1.17)	10.4(0.41)	13.7(0.54)	2.4(0.09)	12.0(0.47)	14.0(0.55)
6	1/8	-CF-ML6-NS2	31.3(1.23)	10.4(0.41)	15.3(0.60)	4.8(0.19)	14.0(0.55)	14.0(0.55)
6	1/4	-CF-ML6-NS4	35.8(1.41)	15.0(0.59)	15.3(0.60)	4.8(0.19)	14.0(0.55)	19.0(0.75)
6	3/8	-CF-ML6-NS6	37.7(1.48)	15.0(0.59)	15.3(0.60)	4.8(0.19)	14.0(0.55)	22.0(0.87)
6	1/2	-CF-ML6-NS8	42.5(1.67)	19.8(0.78)	15.3(0.60)	4.8(0.19)	14.0(0.55)	27.0(1.06)
8	1/8	-CF-ML8-NS2	32.1(1.26)	10.4(0.41)	16.2(0.64)	6.4(0.25)	16.0(0.63)	15.0(0.59)
8	1/4	-CF-ML8-NS4	37.0(1.46)	15.0(0.59)	16.2(0.64)	6.4(0.25)	16.0(0.63)	19.0(0.75)
8	3/8	-CF-ML8-NS6	38.5(1.52)	15.0(0.59)	16.2(0.64)	6.4(0.25)	16.0(0.63)	22.0(0.87)
8	1/2	-CF-ML8-NS8	43.3(1.70)	19.8(0.78)	16.2(0.64)	6.4(0.25)	16.0(0.63)	27.0(1.06)
10	1/8	-CF-ML10-NS2	33.0(1.30)	10.4(0.41)	17.2(0.68)	7.9(0.31)	19.0(0.75)	18.0(0.71)
10	1/4	-CF-ML10-NS4	37.8(1.49)	15.0(0.59)	17.2(0.68)	7.9(0.31)	19.0(0.75)	19.0(0.75)
10	3/8	-CF-ML10-NS6	39.4(1.55)	15.0(0.59)	17.2(0.68)	7.9(0.31)	19.0(0.75)	22.0(0.87)
10	1/2	-CF-ML10-NS8	44.2(1.74)	19.8(0.78)	17.2(0.68)	7.9(0.31)	19.0(0.75)	27.0(1.06)

Female Connectors

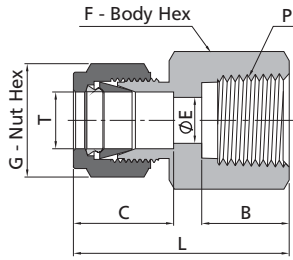

Metric Tube				NPT Thread					
T-Tube O.D. (mm)	P-NPT Size	Basic Ordering Number	Dimensions, mm (in.)						
			L	B	C	E	G	F	
12	1/4	-CF-ML12-NS4	40.3(1.59)	15.0(0.59)	22.8(0.90)	9.5(0.37)	22.0(0.87)	22.0(0.87)	
12	3/8	-CF-ML12-NS6	41.9(1.65)	15.0(0.59)	22.8(0.90)	9.5(0.37)	22.0(0.87)	22.0(0.87)	
12	1/2	-CF-ML12-NS8	46.7(1.84)	19.8(0.78)	22.8(0.90)	9.5(0.37)	22.0(0.87)	27.0(1.06)	
12	3/4	-CF-ML12-NS12	49.1(1.93)	20.6(0.81)	22.8(0.90)	9.5(0.37)	22.0(0.87)	35.0(1.38)	
14	3/4	-CF-ML14-NS12	49.7(1.96)	20.6(0.81)	24.4(0.96)	11.1(0.44)	25.0(0.98)	35.0(1.38)	
15	1/2	-CF-ML15-NS8	46.7(1.84)	19.8(0.78)	24.4(0.96)	11.9(0.47)	25.0(0.98)	27.0(1.06)	
16	3/8	-CF-ML16-NS6	41.9(1.65)	15.0(0.59)	24.4(0.96)	12.7(0.50)	25.0(0.98)	27.0(1.06)	
16	1/2	-CF-ML16-NS8	46.9(1.85)	19.8(0.78)	24.4(0.96)	12.7(0.50)	25.0(0.98)	27.0(1.06)	
20	1/2	-CF-ML20-NS8	47.9(1.89)	19.8(0.78)	26.0(1.02)	15.9(0.63)	32.0(1.26)	30.0(1.18)	
20	3/4	-CF-ML20-NS12	49.7(1.96)	20.6(0.81)	26.0(1.02)	15.9(0.63)	32.0(1.26)	35.0(1.38)	
22	3/4	-CF-ML22-NS12	49.7(1.96)	20.6(0.81)	26.0(1.02)	18.3(0.72)	32.0(1.26)	35.0(1.38)	
22	1	-CF-ML22-NS16	57.9(2.28)	25.4(1.00)	26.0(1.02)	18.3(0.72)	32.0(1.26)	41.0(1.61)	
25	3/4	-CF-ML25-NS12	53.4(2.10)	20.6(0.81)	31.3(1.23)	21.8(0.86)	38.0(1.50)	35.0(1.38)	
25	1	-CF-ML25-NS16	62.3(2.45)	25.4(1.00)	31.3(1.23)	21.8(0.86)	38.0(1.50)	41.0(1.61)	

Female Connectors

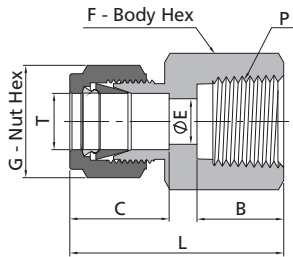

Metric Tube				ISO Tapered Thread (RT)					
T-Tube O.D. (mm)	P-RT Size	Basic Ordering Number	Dimensions, mm (in.)						
			L	B	C	E	G	F	
3	1/8	-CF-ML3-RT2	28.7(1.13)	10.4(0.41)	12.9(0.51)	2.4(0.09)	12.0(0.47)	14.0(0.55)	
6	1/8	-CF-ML6-RT2	31.3(1.23)	10.4(0.41)	15.3(0.60)	4.8(0.19)	14.0(0.55)	14.0(0.55)	
6	1/4	-CF-ML6-RT4	35.8(1.41)	15.0(0.59)	15.3(0.60)	4.8(0.19)	14.0(0.55)	19.0(0.75)	
6	3/8	-CF-ML6-RT6	37.9(1.49)	15.0(0.59)	15.3(0.60)	4.8(0.19)	14.0(0.55)	22.0(0.87)	
6	1/2	-CF-ML6-RT8	42.5(1.67)	19.8(0.78)	15.3(0.60)	4.8(0.19)	14.0(0.55)	27.0(1.06)	
8	1/8	-CF-ML8-RT2	32.1(1.26)	10.4(0.41)	16.2(0.64)	6.4(0.25)	16.0(0.63)	15.0(0.59)	
8	1/4	-CF-ML8-RT4	37.0(1.46)	15.0(0.59)	16.2(0.64)	6.4(0.25)	16.0(0.63)	19.0(0.75)	
8	3/8	-CF-ML8-RT6	38.5(1.52)	15.0(0.59)	16.2(0.64)	6.4(0.25)	16.0(0.63)	22.0(0.87)	
8	1/2	-CF-ML8-RT8	43.3(1.70)	19.8(0.78)	16.2(0.64)	6.4(0.25)	16.0(0.63)	27.0(1.06)	
10	1/8	-CF-ML10-RT2	33.0(1.30)	10.4(0.41)	17.2(0.68)	7.9(0.31)	19.0(0.75)	18.0(0.71)	
10	1/4	-CF-ML10-RT4	37.8(1.49)	15.0(0.59)	17.2(0.68)	7.9(0.31)	19.0(0.75)	19.0(0.75)	
10	3/8	-CF-ML10-RT6	39.4(1.55)	15.0(0.59)	17.2(0.68)	7.9(0.31)	19.0(0.75)	22.0(0.87)	
10	1/2	-CF-ML10-RT8	44.2(1.74)	19.8(0.78)	17.2(0.68)	7.9(0.31)	19.0(0.75)	27.0(1.06)	
12	1/8	-CF-ML12-RT2	35.5(1.40)	10.4(0.41)	22.8(0.90)	8.3(0.33)	22.0(0.87)	22.0(0.87)	
12	1/4	-CF-ML12-RT4	40.3(1.59)	15.0(0.59)	22.8(0.90)	9.5(0.37)	22.0(0.87)	22.0(0.87)	
12	3/8	-CF-ML12-RT6	41.9(1.65)	15.0(0.59)	22.8(0.90)	9.5(0.37)	22.0(0.87)	22.0(0.87)	
12	1/2	-CF-ML12-RT8	46.7(1.84)	19.8(0.78)	22.8(0.90)	9.5(0.37)	22.0(0.87)	27.0(1.06)	
12	3/4	-CF-ML12-RT12	49.0(1.93)	20.6(0.81)	22.8(0.90)	9.5(0.37)	22.0(0.87)	35.0(1.38)	
15	1/2	-CF-ML15-RT8	46.7(1.84)	19.8(0.78)	24.4(0.96)	11.9(0.47)	25.0(0.98)	27.0(1.06)	
16	1/2	-CF-ML16-RT8	48.4(1.91)	19.8(0.78)	24.4(0.96)	12.7(0.50)	25.0(0.98)	27.0(1.06)	
16	3/4	-CF-ML16-RT12	49.7(1.96)	20.6(0.81)	24.4(0.96)	12.7(0.50)	25.0(0.98)	35.0(1.38)	
20	1/2	-CF-ML20-RT8	47.9(1.89)	19.8(0.78)	26.0(1.02)	15.9(0.63)	32.0(1.26)	30.0(1.18)	
20	3/4	-CF-ML20-RT12	49.7(1.96)	20.6(0.81)	26.0(1.02)	15.9(0.63)	32.0(1.26)	35.0(1.38)	
22	3/4	-CF-ML22-RT12	49.7(1.96)	20.6(0.81)	26.0(1.02)	18.3(0.72)	32.0(1.26)	35.0(1.38)	
22	1	-CF-ML22-RT16	57.9(2.28)	25.4(1.00)	26.0(1.02)	18.3(0.72)	32.0(1.26)	41.0(1.61)	
25	3/4	-CF-ML25-RT12	53.4(2.10)	20.6(0.81)	31.3(1.23)	21.8(0.86)	38.0(1.50)	35.0(1.38)	
25	1	-CF-ML25-RT16	62.3(2.45)	25.4(1.00)	31.3(1.23)	21.8(0.86)	38.0(1.50)	41.0(1.61)	

Female Connectors

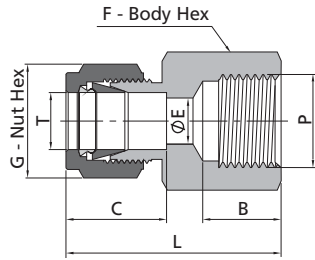

Metric Tube			ISO Parallel Thread (RP)					
T-Tube O.D. (mm)	P-RP Size	Basic Ordering Number	Dimensions, mm (in.)					
			L	B	C	E	G	F
6	1/8	-CF-ML6-RP2	33.5(1.32)	15.5(0.61)	15.3(0.60)	4.8(0.19)	14.0(0.55)	14.0(0.55)
6	1/4	-CF-ML6-RP4	39.4(1.55)	15.5(0.61)	15.3(0.60)	4.8(0.19)	14.0(0.55)	19.0(0.75)
22	3/4	-CF-ML22-RP12	53.3(2.10)	20.5(0.81)	26.0(1.02)	18.3(0.72)	32.0(1.26)	35.0(1.38)
25	1	-CF-ML25-RP16	63.9(2.52)	23.5(0.93)	31.3(1.23)	21.8(0.86)	38.0(1.50)	40.0(1.57)

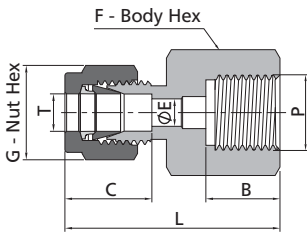

Metric Tube			ISO Parallel Thread (RG)					
T-Tube O.D. (mm)	P-RG Size	Basic Ordering Number	Dimensions, mm (in.)					
			L	B	C	E	G	F
3	1/4	-CF-ML3-RG4	35.3(1.39)	12.9(0.51)	12.9(0.51)	2.4(0.09)	12.0(0.47)	19.0(0.75)
6	1/4	-CF-ML6-RG4	37.6(1.48)	12.9(0.51)	15.3(0.60)	4.8(0.19)	14.0(0.55)	19.0(0.75)
6	3/8	-CF-ML6-RG6	37.6(1.48)	14.2(0.56)	15.3(0.60)	4.8(0.19)	14.0(0.55)	24.0(0.94)
6	1/2	-CF-ML6-RG8	43.5(1.71)	18.8(0.74)	15.3(0.60)	4.8(0.19)	14.0(0.55)	27.0(1.06)
8	1/4	-CF-ML8-RG4	38.5(1.52)	12.9(0.51)	16.2(0.64)	5.5(0.22)	16.0(0.63)	19.0(0.75)
8	3/8	-CF-ML8-RG6	36.2(1.43)	14.2(0.56)	16.2(0.64)	6.4(0.25)	16.0(0.63)	24.0(0.94)
8	1/2	-CF-ML8-RG8	41.0(1.61)	18.8(0.74)	16.2(0.64)	6.4(0.25)	16.0(0.63)	27.0(1.06)
10	1/4	-CF-ML10-RG4	39.4(1.55)	12.9(0.51)	17.2(0.68)	5.5(0.22)	19.0(0.75)	19.0(0.75)
10	3/8	-CF-ML10-RG6	38.8(1.53)	14.2(0.56)	17.2(0.68)	6.4(0.25)	19.0(0.75)	24.0(0.94)
10	1/2	-CF-ML10-RG8	42.1(1.66)	18.8(0.74)	17.2(0.68)	7.9(0.31)	19.0(0.75)	27.0(1.06)
12	1/4	-CF-ML12-RG4	41.9(1.65)	12.9(0.51)	22.8(0.90)	5.5(0.22)	22.0(0.87)	22.0(0.87)
12	3/8	-CF-ML12-RG6	44.4(1.75)	14.2(0.56)	22.8(0.90)	6.4(0.25)	22.0(0.87)	24.0(0.94)
12	1/2	-CF-ML12-RG8	48.2(1.90)	18.8(0.74)	22.8(0.90)	7.1(0.28)	22.0(0.87)	27.0(1.06)
20	1/2	-CF-ML20-RG8	54.3(2.14)	18.8(0.74)	26.0(1.02)	7.1(0.28)	32.0(1.26)	30.0(1.18)
22	1/2	-CF-ML22-RG8	54.3(2.14)	18.8(0.74)	26.0(1.02)	7.1(0.28)	32.0(1.26)	30.0(1.18)

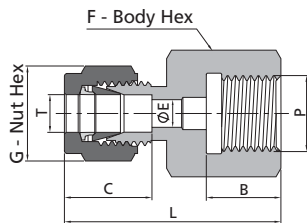

Metric Tube			ISO Parallel Thread (RJ)					
T-Tube O.D. (mm)	P-RJ Size	Basic Ordering Number	Dimensions, mm (in.)					
			L	B	C	E	G	F
6	1/4	-CF-ML6-RJ4	37.6(1.48)	12.9(0.51)	15.3(0.60)	4.8(0.19)	14.0(0.55)	19.0(0.75)
6	3/8	-CF-ML6-RJ6	37.6(1.48)	15.8(0.62)	15.3(0.60)	4.8(0.19)	14.0(0.55)	24.0(0.94)
6	1/2	-CF-ML6-RJ8	43.5(1.71)	18.8(0.74)	15.3(0.60)	4.8(0.19)	14.0(0.55)	27.0(1.06)
8	1/4	-CF-ML8-RJ4	38.5(1.52)	12.9(0.51)	16.2(0.64)	5.5(0.22)	16.0(0.63)	19.0(0.75)
8	3/8	-CF-ML8-RJ6	36.2(1.43)	15.8(0.62)	16.2(0.64)	6.5(0.26)	16.0(0.63)	24.0(0.94)
8	1/2	-CF-ML8-RJ8	41.0(1.61)	18.8(0.74)	16.2(0.64)	7.0(0.28)	16.0(0.63)	27.0(1.06)
10	1/4	-CF-ML10-RJ4	39.4(1.55)	12.9(0.51)	17.2(0.68)	5.5(0.22)	19.0(0.75)	19.0(0.75)
10	3/8	-CF-ML10-RJ6	38.8(1.53)	15.8(0.62)	17.2(0.68)	6.5(0.26)	19.0(0.75)	24.0(0.94)
10	1/2	-CF-ML10-RJ8	42.1(1.66)	18.8(0.74)	17.2(0.68)	7.0(0.28)	19.0(0.75)	27.0(1.06)
12	1/4	-CF-ML12-RJ4	41.9(1.65)	12.9(0.51)	22.8(0.90)	5.5(0.22)	22.0(0.87)	22.0(0.87)
12	3/8	-CF-ML12-RJ6	44.4(1.75)	15.8(0.62)	22.8(0.90)	6.5(0.26)	22.0(0.87)	24.0(0.94)
12	1/2	-CF-ML12-RJ8	48.2(1.90)	18.8(0.74)	22.8(0.90)	7.0(0.28)	22.0(0.87)	27.0(1.06)

Adapt to Japanese Gauge stud (JIS B7505)

A-32 6 Series Tube Fittings

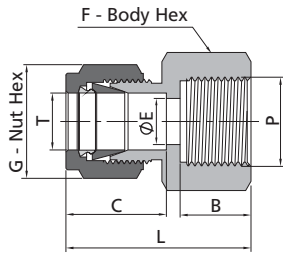

Metric Tube			Metric Thread					
T-Tube O.D. (mm)	P-Metric Thread Size	Basic Ordering Number	Dimensions, mm (in.)					
			L	B	C	E	G	F
6	M10 x 1	-CF-ML6-MS10	32.7(1.29)	11.0(0.43)	15.3(0.60)	4.7(0.19)	14.0(0.55)	16.0(0.63)
6	M14 x 1.5	-CF-ML6-MS14	36.1(1.42)	13.0(0.51)	15.3(0.60)	4.8(0.19)	14.0(0.55)	19.0(0.75)
6	M20 x 1.5	-CF-ML6-MS20	37.7(1.48)	16.0(0.63)	15.3(0.60)	4.8(0.19)	14.0(0.55)	27.0(1.06)
8	M8 x 1	-CF-ML8-MS8	31.6(1.24)	9.0(0.35)	16.2(0.64)	3.0(0.12)	16.0(0.63)	14.0(0.55)
8	M10 x 1	-CF-ML8-MS10	33.6(1.32)	11.0(0.43)	16.2(0.64)	4.0(0.16)	16.0(0.63)	16.0(0.63)
8	M14 x 1.5	-CF-ML8-MS14	35.6(1.40)	13.0(0.51)	16.2(0.64)	6.4(0.25)	16.0(0.63)	19.0(0.75)
8	M20 x 1.5	-CF-ML8-MS20	38.6(1.52)	16.0(0.63)	16.2(0.64)	6.4(0.25)	16.0(0.63)	27.0(1.06)
10	M16 x 1.5	-CF-ML10-MS16	38.1(1.50)	14.0(0.55)	17.2(0.68)	7.9(0.31)	19.0(0.75)	22.0(0.87)
12	M20 x 1.5	-CF-ML12-MS20	44.9(1.77)	16.0(0.63)	22.8(0.90)	9.5(0.37)	22.0(0.87)	27.0(1.06)
14	M10 x 1	-CF-ML14-MS10	42.5(1.67)	11.0(0.43)	24.4(0.96)	4.0(0.16)	25.0(0.98)	24.0(0.94)
14	M20 x 1.5	-CF-ML14-MS20	44.9(1.77)	16.0(0.63)	24.4(0.96)	10.8(0.43)	25.0(0.98)	27.0(1.06)
14	M22 x 1.5	-CF-ML14-MS22	45.9(1.81)	17.0(0.67)	24.4(0.96)	11.1(0.44)	25.0(0.98)	27.0(1.06)
16	M20 x 1.5	-CF-ML16-MS20	44.9(1.77)	16.0(0.63)	24.4(0.96)	10.8(0.43)	25.0(0.98)	27.0(1.06)
20	M20 x 1.5	-CF-ML20-MS20	46.5(1.83)	16.0(0.63)	26.0(1.02)	10.8(0.43)	32.0(1.26)	30.0(1.18)
25	M27 x 2	-CF-ML25-MS27	54.4(2.14)	18.0(0.71)	31.3(1.23)	16.1(0.63)	38.0(1.50)	35.0(1.38)

Bulkhead Female Connectors

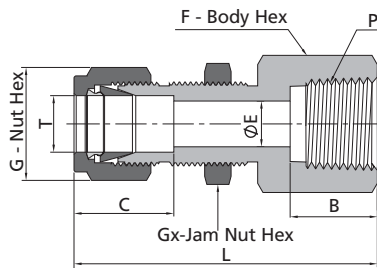

Fractional Tube			NPT Thread								
T-Tube O.D. (in.)	P-NPT Size	Basic Ordering Number	Dimensions, in. (mm)							Panel Hole Size in. (mm)	Max. Panel Thickness in. (mm)
			L	B	C	E	G	F	Gx		
1/16	1/16	-BCF-FL1-NS1	1.19(30.2)	0.39(9.9)	0.34(8.6)	0.05(1.3)	0.31(7.9)	0.44(11.1)	0.31(7.9)	0.20(5.2)	0.13(3.2)
1/16	1/8	-BCF-FL1-NS2	1.20(30.7)	0.41(10.4)	0.34(8.6)	0.05(1.3)	0.31(7.9)	0.56(14.3)	0.31(7.9)	0.20(5.2)	0.13(3.2)
1/8	1/8	-BCF-FL2-NS2	1.76(44.7)	0.41(10.4)	0.50(12.7)	0.09(2.3)	0.44(11.1)	0.56(14.3)	0.50(12.7)	0.33(8.3)	0.50(12.7)
1/8	1/4	-BCF-FL2-NS4	1.95(49.6)	0.59(15.0)	0.50(12.7)	0.09(2.3)	0.44(11.1)	0.75(19.1)	0.50(12.7)	0.33(8.3)	0.50(12.7)
3/16	1/8	-BCF-FL3-NS2	1.79(45.5)	0.41(10.4)	0.54(13.7)	0.12(3.0)	0.50(12.7)	0.56(14.3)	0.56(14.3)	0.39(9.9)	0.50(12.7)
1/4	1/8	-BCF-FL4-NS2	1.85(47.0)	0.41(10.4)	0.60(15.2)	0.19(4.8)	0.56(14.3)	0.63(15.9)	0.63(15.9)	0.45(11.5)	0.40(10.2)
1/4	1/4	-BCF-FL4-NS4	2.04(51.8)	0.59(15.0)	0.60(15.2)	0.19(4.8)	0.56(14.3)	0.75(19.1)	0.63(15.9)	0.45(11.5)	0.40(10.2)
1/4	3/8	-BCF-FL4-NS6	2.10(53.3)	0.59(15.0)	0.60(15.2)	0.19(4.8)	0.56(14.3)	0.87(22.2)	0.63(15.9)	0.45(11.5)	0.40(10.2)
1/4	1/2	-BCF-FL4-NS8	2.29(58.2)	0.78(19.8)	0.60(15.2)	0.19(4.8)	0.56(14.3)	1.06(27.0)	0.63(15.9)	0.45(11.5)	0.40(10.2)
5/16	1/8	-BCF-FL5-NS2	1.96(49.8)	0.41(10.4)	0.64(16.3)	0.25(6.4)	0.63(15.9)	0.69(17.5)	0.69(17.5)	0.52(13.1)	0.44(11.2)
5/16	1/4	-BCF-FL5-NS4	2.38(60.5)	0.59(15.0)	0.64(16.3)	0.25(6.4)	0.63(15.9)	0.75(19.1)	0.69(17.5)	0.52(13.1)	0.44(11.2)
3/8	1/8	-BCF-FL6-NS2	1.98(50.3)	0.41(10.4)	0.66(16.8)	0.28(7.1)	0.69(17.5)	0.75(19.1)	0.75(19.1)	0.58(14.7)	0.44(11.2)
3/8	1/4	-BCF-FL6-NS4	2.17(55.1)	0.59(15.0)	0.66(16.8)	0.28(7.1)	0.69(17.5)	0.75(19.1)	0.75(19.1)	0.58(14.7)	0.44(11.2)
3/8	3/8	-BCF-FL6-NS6	2.23(56.6)	0.59(15.0)	0.66(16.8)	0.28(7.1)	0.69(17.5)	0.87(22.2)	0.75(19.1)	0.58(14.7)	0.44(11.2)
3/8	1/2	-BCF-FL6-NS8	2.42(61.5)	0.78(19.8)	0.66(16.8)	0.28(7.1)	0.69(17.5)	1.06(27.0)	0.75(19.1)	0.58(14.7)	0.44(11.2)
3/8	3/4	-BCF-FL6-NS12	2.57(65.3)	0.81(20.6)	0.66(16.8)	0.28(7.1)	0.69(17.5)	1.31(33.3)	0.75(19.1)	0.58(14.7)	0.44(11.2)
1/2	1/4	-BCF-FL8-NS4	2.37(60.2)	0.59(15.0)	0.90(22.9)	0.41(10.4)	0.87(22.2)	0.94(23.8)	0.94(23.8)	0.76(19.4)	0.50(12.7)
1/2	3/8	-BCF-FL8-NS6	2.43(61.7)	0.59(15.0)	0.90(22.9)	0.41(10.4)	0.87(22.2)	0.94(23.8)	0.94(23.8)	0.76(19.4)	0.50(12.7)
1/2	1/2	-BCF-FL8-NS8	2.62(66.5)	0.78(19.8)	0.90(22.9)	0.41(10.4)	0.87(22.2)	1.06(27.0)	0.94(23.8)	0.76(19.4)	0.50(12.7)
1/2	3/4	-BCF-FL8-NS12	2.68(68.1)	0.81(20.6)	0.90(22.9)	0.41(10.4)	0.87(22.2)	1.31(33.3)	0.94(23.8)	0.76(19.4)	0.50(12.7)

Bulkhead Female Connectors

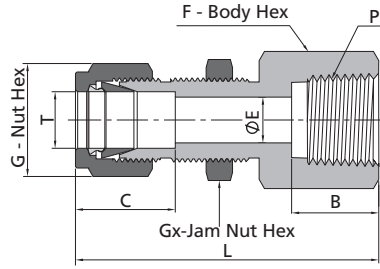

Fractional Tube			NPT Thread								
T-Tube O.D. (in.)	P-NPT Size	Basic Ordering Number	Dimensions, in. (mm)							Panel Hole Size in. (mm)	Max. Panel Thickness in. (mm)
			L	B	C	E	G	F	Gx		
5/8	3/8	-BCF-FL10-NS6	2.46(62.5)	0.59(15.0)	0.96(24.4)	0.50(12.7)	1.00(25.4)	1.06(27.0)	1.06(27.0)	0.89(22.6)	0.59(15.1)
5/8	1/2	-BCF-FL10-NS8	2.65(67.3)	0.78(19.8)	0.96(24.4)	0.50(12.7)	1.00(25.4)	1.06(27.0)	1.06(27.0)	0.89(22.6)	0.59(15.1)
3/4	1/2	-BCF-FL12-NS8	2.84(72.2)	0.78(19.8)	0.96(24.4)	0.62(15.7)	1.13(28.6)	1.19(30.2)	1.19(30.2)	1.02(25.8)	0.78(19.8)
3/4	3/4	-BCF-FL12-NS12	2.90(73.7)	0.81(20.6)	0.96(24.4)	0.62(15.7)	1.13(28.6)	1.31(33.3)	1.19(30.2)	1.02(25.8)	0.78(19.8)
7/8	3/4	-BCF-FL14-NS12	3.18(80.8)	0.81(20.6)	1.02(25.9)	0.72(18.3)	1.25(31.8)	1.31(33.3)	1.31(33.3)	1.14(29.0)	0.94(23.8)
1	3/4	-BCF-FL16-NS12	3.33(84.7)	0.81(20.6)	1.23(31.2)	0.88(22.4)	1.50(38.1)	1.63(41.3)	1.63(41.3)	1.33(33.7)	0.94(23.8)
1	1	-BCF-FL16-NS16	3.68(93.5)	1.00(25.4)	1.23(31.2)	0.88(22.4)	1.50(38.1)	1.63(41.3)	1.63(41.3)	1.33(33.7)	0.94(23.8)

Metric Tube			NPT Thread								
T-Tube O.D. (mm)	P-NPT Size	Basic Ordering Number	Dimensions, mm (in.)							Panel Hole Size mm (in.)	Max. Panel Thickness mm (in.)
			L	B	C	E	G	F	Gx		
6	1/8	-BCF-ML6-NS2	47.2(1.86)	10.4(0.41)	15.3(0.60)	4.8(0.19)	14.0(0.55)	16.0(0.63)	16.0(0.63)	11.5(0.45)	10.2(0.40)
6	1/4	-BCF-ML6-NS4	51.8(2.04)	15.0(0.59)	15.3(0.60)	4.8(0.19)	14.0(0.55)	19.0(0.75)	16.0(0.63)	11.5(0.45)	10.2(0.40)
8	1/8	-BCF-ML8-NS2	49.6(1.95)	10.4(0.41)	16.2(0.64)	6.4(0.25)	16.0(0.63)	18.0(0.71)	18.0(0.71)	13.1(0.52)	11.2(0.44)
10	1/4	-BCF-ML10-NS4	55.2(2.17)	15.0(0.59)	17.2(0.68)	7.9(0.31)	19.0(0.75)	22.0(0.87)	22.0(0.87)	16.3(0.64)	11.2(0.44)
12	3/8	-BCF-ML12-NS6	62.9(2.48)	15.0(0.59)	22.8(0.90)	9.5(0.37)	22.0(0.87)	24.0(0.94)	24.0(0.94)	19.5(0.77)	12.7(0.50)
12	1/2	-BCF-ML12-NS8	66.5(2.62)	19.8(0.78)	22.8(0.90)	9.5(0.37)	22.0(0.87)	27.0(1.06)	24.0(0.94)	19.5(0.77)	12.7(0.50)

Unions

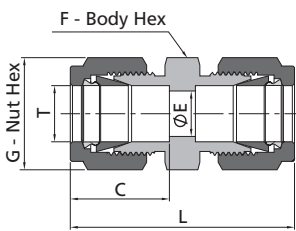

Fractional Tube		NPT Thread				
T-Tube O.D. (in.)	Basic Ordering Number	Dimensions, in. (mm)				
		L	C	G	F	E
1/16	-U-FL1	0.99(25.1)	0.34(8.6)	0.31(7.9)	0.31(7.9)	0.05(1.3)
1/8	-U-FL2	1.40(35.6)	0.50(12.7)	0.44(11.1)	0.44(11.1)	0.09(2.3)
3/16	-U-FL3	1.47(37.3)	0.54(13.7)	0.50(12.7)	0.50(12.7)	0.12(3.0)
1/4	-U-FL4	1.61(40.9)	0.60(15.2)	0.56(14.3)	0.50(12.7)	0.19(4.8)
5/16	-U-FL5	1.69(42.9)	0.64(16.2)	0.63(15.9)	0.56(14.3)	0.25(6.4)
3/8	-U-FL6	1.77(45.0)	0.66(16.8)	0.69(17.5)	0.63(15.9)	0.28(7.1)
1/2	-U-FL8	2.02(51.3)	0.90(22.9)	0.87(22.2)	0.81(20.6)	0.41(10.4)
5/8	-U-FL10	2.05(52.1)	0.96(24.4)	1.00(25.4)	0.94(23.9)	0.50(12.7)
3/4	-U-FL12	2.11(53.6)	0.96(24.4)	1.13(28.6)	1.06(27.0)	0.62(15.7)
7/8	-U-FL14	2.19(55.7)	1.02(25.9)	1.25(31.8)	1.19(30.2)	0.72(18.3)
1	-U-FL16	2.55(64.8)	1.23(31.2)	1.5(38.1)	1.37(34.9)	0.88(22.4)
1 1/8	-U-FL18	3.47(88.2)	1.44(36.7)	1.75(44.5)	1.63(41.3)	0.97(24.6)
1 1/4	-U-FL20	3.63(92.2)	1.62(41.1)	1.87(47.6)	1.75(44.5)	1.09(27.7)
1 1/2	-U-FL24	4.25(108.0)	1.97(50.0)	2.25(57.2)	2.13(54.0)	1.34(34.0)

Unions

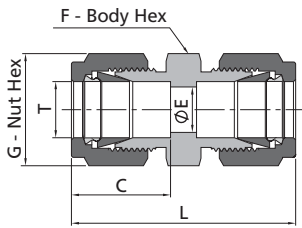

Metric Tube						
T-Tube O.D. (mm)	Basic Ordering Number	Dimensions, mm (in.)				
		L	C	G	F	E
2	-U-ML2	35.6(1.40)	12.9(0.51)	12.0(0.47)	12.0(0.47)	1.7(0.07)
3	-U-ML3	35.3(1.39)	12.9(0.51)	12.0(0.47)	12.0(0.47)	2.4(0.09)
4	-U-ML4	37.3(1.47)	13.7(0.54)	12.0(0.47)	12.0(0.47)	2.4(0.09)
6	-U-ML6	41.0(1.61)	15.3(0.60)	14.0(0.55)	14.0(0.55)	4.8(0.19)
8	-U-ML8	43.2(1.70)	16.2(0.64)	16.0(0.63)	15.0(0.59)	6.4(0.25)
10	-U-ML10	46.2(1.82)	17.2(0.68)	19.0(0.75)	18.0(0.71)	7.9(0.31)
12	-U-ML12	51.2(2.02)	22.8(0.90)	22.0(0.87)	22.0(0.87)	9.5(0.37)
14	-U-ML14	52.0(2.05)	24.4(0.96)	25.0(0.98)	24.0(0.94)	11.1(0.44)
15	-U-ML15	52.0(2.05)	24.4(0.96)	25.0(0.98)	24.0(0.94)	11.9(0.47)
16	-U-ML16	52.0(2.05)	24.4(0.96)	25.0(0.98)	24.0(0.94)	12.7(0.50)
18	-U-ML18	53.5(2.11)	24.4(0.96)	30.0(1.18)	27.0(1.06)	15.1(0.59)
20	-U-ML20	55.0(2.17)	26.0(1.02)	32.0(1.26)	30.0(1.18)	15.9(0.63)
22	-U-ML22	55.0(2.17)	26.0(1.02)	32.0(1.26)	30.0(1.18)	18.3(0.72)
25	-U-ML25	65.0(2.56)	31.3(1.23)	38.0(1.50)	35.0(1.38)	21.8(0.86)
28	-U-ML28	85.0(3.35)	36.6(1.44)	46.0(1.81)	41.0(1.61)	21.8(0.86)
30	-U-ML30	92.7(3.65)	39.6(1.56)	50.0(1.97)	46.0(1.81)	26.2(1.03)
32	-U-ML32	97.3(3.83)	42.0(1.65)	50.0(1.97)	46.0(1.81)	28.6(1.13)
38	-U-ML38	113.6(4.47)	49.4(1.94)	60.0(2.36)	55.0(2.17)	33.7(1.33)

Conversion Unions

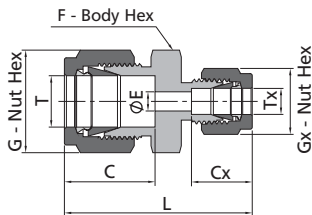

Fractional Tube									
T-Tube O.D. (in.)	Tx-Tube O.D. (mm)	Basic Ordering Number	Dimensions, in. (mm)						
			L	C	G	F	E	Cx	Gx
1/8	3	-U-FL2-ML3	1.39(35.2)	0.50(12.7)	0.44(11.1)	0.47(12.0)	0.09(2.3)	0.51(12.9)	0.47(12.0)
1/4	4	-U-FL4-ML4	1.55(39.4)	0.60(15.2)	0.56(14.3)	0.55(14.0)	0.09(2.4)	0.54(13.7)	0.47(12.0)
1/4	6	-U-FL4-ML6	1.62(41.2)	0.60(15.2)	0.56(14.3)	0.55(14.0)	0.19(4.8)	0.60(15.3)	0.55(14.0)
3/8	6	-U-FL6-ML6	1.72(43.7)	0.66(16.8)	0.69(17.5)	0.63(16.0)	0.19(4.8)	0.60(15.3)	0.55(14.0)
3/8	8	-U-FL6-ML8	1.75(44.5)	0.66(16.8)	0.69(17.5)	0.63(16.0)	0.25(6.4)	0.64(16.2)	0.63(16.0)
1/2	6	-U-FL8-ML6	1.88(47.7)	0.90(22.9)	0.87(22.2)	0.87(22.0)	0.19(4.8)	0.60(15.3)	0.55(14.0)
1/2	10	-U-FL8-ML10	1.93(48.9)	0.90(22.9)	0.87(22.2)	0.87(22.0)	0.31(7.9)	0.68(17.2)	0.75(19.0)
1/2	12	-U-FL8-ML12	2.02(51.4)	0.90(22.9)	0.87(22.2)	0.87(22.0)	0.37(9.5)	0.90(22.8)	0.87(22.0)
3/4	12	-U-FL12-ML12	2.13(54.2)	0.96(24.4)	1.13(28.6)	1.06(27.0)	0.37(9.5)	0.90(22.8)	0.87(22.0)
3/4	16	-U-FL12-ML16	2.12(53.9)	0.96(24.4)	1.13(28.6)	1.06(27.0)	0.50(12.7)	0.96(24.4)	0.98(25.0)
3/4	18	-U-FL12-ML18	2.11(53.6)	0.96(24.4)	1.13(28.6)	1.06(27.0)	0.59(15.1)	0.96(24.4)	1.18(30.0)
1	25	-U-FL16-ML25	2.65(67.4)	1.23(31.2)	1.50(38.1)	1.38(35.0)	0.86(21.8)	1.23(31.3)	1.50(38.0)

Metric Tube			Fractional Tube							
T-Tube O.D. (mm)	Tx-Tube O.D. (in.)	Basic Ordering Number	Dimensions, mm (in.)							
			L	C	G	F	E	Cx	Gx	
4	1/8	-U-ML4-FL2	36.5(1.44)	13.7(0.54)	12.0(0.47)	12.0(0.47)	2.4(0.09)	12.7(0.50)	11.1(0.44)	
6	1/8	-U-ML6-FL2	38.5(1.52)	15.3(0.60)	14.0(0.55)	14.0(0.55)	2.4(0.09)	12.7(0.50)	11.1(0.44)	
8	1/4	-U-ML8-FL4	42.3(1.67)	16.2(0.64)	16.0(0.63)	15.0(0.59)	4.8(0.19)	15.2(0.60)	14.3(0.56)	
10	1/8	-U-ML10-FL2	41.8(1.65)	17.2(0.68)	19.0(0.75)	18.0(0.71)	2.4(0.09)	12.7(0.50)	11.1(0.44)	
10	1/4	-U-ML10-FL4	44.5(1.75)	17.2(0.68)	19.0(0.75)	18.0(0.71)	4.8(0.19)	15.2(0.60)	14.3(0.56)	
10	5/16	-U-ML10-FL5	45.1(1.78)	17.2(0.68)	19.0(0.75)	18.0(0.71)	6.4(0.25)	16.2(0.64)	15.9(0.63)	
10	3/8	-U-ML10-FL6	45.9(1.81)	17.2(0.68)	19.0(0.75)	18.0(0.71)	7.1(0.28)	16.8(0.66)	17.5(0.69)	
12	5/16	-U-ML12-FL5	47.8(1.88)	22.8(0.90)	22.0(0.87)	22.0(0.87)	6.4(0.25)	16.2(0.64)	15.9(0.63)	
12	3/8	-U-ML12-FL6	48.4(1.91)	22.8(0.90)	22.0(0.87)	22.0(0.87)	7.1(0.28)	16.8(0.66)	17.5(0.69)	
15	1/2	-U-ML15-FL8	52.0(2.05)	24.4(0.96)	25.0(0.98)	24.0(0.94)	10.4(0.41)	22.9(0.90)	22.2(0.87)	
16	5/8	-U-ML16-FL10	52.0(2.05)	24.4(0.96)	25.0(0.98)	24.0(0.94)	12.7(0.50)	24.4(0.96)	25.4(1.00)	
20	1/2	-U-ML20-FL8	55.0(2.17)	26.0(1.02)	32.0(1.26)	30.0(1.18)	10.4(0.41)	22.9(0.90)	22.2(0.87)	

Reducing Unions

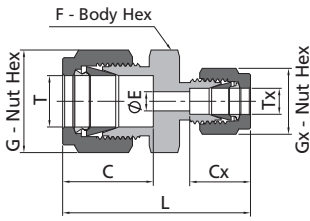

Fractional Tube			Dimensions, in. (mm)							
T-Tube O.D. (in.)	Tx-Tube O.D. (in.)	Basic Ordering Number	L	C	G	F	E	Cx	Gx	
1/8	1/16	-U-FL2-FL1	1.22(31.0)	0.50(12.7)	0.44(11.1)	0.44(11.1)	0.05(1.3)	0.34(8.6)	0.31(7.9)	
3/16	1/16	-U-FL3-FL1	1.27(32.3)	0.54(13.7)	0.50(12.7)	0.44(11.1)	0.05(1.3)	0.34(8.6)	0.31(7.9)	
3/16	1/8	-U-FL3-FL2	1.44(36.6)	0.54(13.7)	0.50(12.7)	0.44(11.1)	0.09(2.3)	0.50(12.7)	0.44(11.1)	
1/4	1/16	-U-FL4-FL1	1.35(34.3)	0.60(15.2)	0.56(14.3)	0.50(12.7)	0.05(1.3)	0.34(8.6)	0.31(7.9)	
1/4	1/8	-U-FL4-FL2	1.52(38.6)	0.60(15.2)	0.56(14.3)	0.50(12.7)	0.09(2.3)	0.50(12.7)	0.44(11.1)	
1/4	3/16	-U-FL4-FL3	1.55(39.4)	0.60(15.2)	0.56(14.3)	0.50(12.7)	0.12(3.0)	0.54(13.7)	0.50(12.7)	
5/16	1/8	-U-FL5-FL2	1.56(39.6)	0.64(16.2)	0.63(15.9)	0.56(14.3)	0.09(2.3)	0.50(12.7)	0.44(11.1)	
5/16	1/4	-U-FL5-FL4	1.66(42.2)	0.64(16.2)	0.63(15.9)	0.56(14.3)	0.19(4.8)	0.60(15.2)	0.56(14.3)	
3/8	1/16	-U-FL6-FL1	1.44(36.6)	0.66(16.8)	0.69(17.5)	0.63(15.9)	0.05(1.3)	0.34(8.6)	0.31(7.9)	
3/8	1/8	-U-FL6-FL2	1.61(40.9)	0.66(16.8)	0.69(17.5)	0.63(15.9)	0.09(2.3)	0.50(12.7)	0.44(11.1)	
3/8	1/4	-U-FL6-FL4	1.70(43.2)	0.66(16.8)	0.69(17.5)	0.63(15.9)	0.19(4.8)	0.60(15.2)	0.56(14.3)	
3/8	5/16	-U-FL6-FL5	1.74(44.2)	0.66(16.8)	0.69(17.5)	0.63(15.9)	0.25(6.4)	0.64(16.2)	0.63(15.9)	
1/2	1/8	-U-FL8-FL2	1.78(45.2)	0.90(22.8)	0.87(22.2)	0.81(20.6)	0.09(2.3)	0.50(12.7)	0.44(11.1)	
1/2	1/4	-U-FL8-FL4	1.85(47.0)	0.90(22.8)	0.87(22.2)	0.81(20.6)	0.19(4.8)	0.60(15.2)	0.56(14.3)	
1/2	3/8	-U-FL8-FL6	1.91(48.5)	0.90(22.8)	0.87(22.2)	0.81(20.6)	0.28(7.1)	0.66(16.8)	0.69(17.5)	
5/8	3/8	-U-FL10-FL6	1.94(49.3)	0.96(24.4)	1.00(25.4)	0.94(23.9)	0.28(7.1)	0.66(16.8)	0.69(17.5)	
5/8	1/2	-U-FL10-FL8	2.05(52.1)	0.96(24.4)	1.00(25.4)	0.94(23.9)	0.41(10.4)	0.90(22.8)	0.87(22.2)	
3/4	1/4	-U-FL12-FL4	1.94(49.3)	0.96(24.4)	1.13(28.6)	1.06(27.0)	0.19(4.8)	0.60(15.2)	0.56(14.3)	
3/4	3/8	-U-FL12-FL6	2.00(50.8)	0.96(24.4)	1.13(28.6)	1.06(27.0)	0.28(7.1)	0.66(16.8)	0.69(17.5)	
3/4	1/2	-U-FL12-FL8	2.11(53.6)	0.96(24.4)	1.13(28.6)	1.06(27.0)	0.41(10.4)	0.90(22.8)	0.87(22.2)	
3/4	5/8	-U-FL12-FL10	2.11(53.6)	0.96(24.4)	1.13(28.6)	1.06(27.0)	0.50(12.7)	0.96(24.4)	1.00(25.4)	
1	1/2	-U-FL16-FL8	2.38(60.5)	1.23(31.2)	1.50(38.1)	1.37(34.9)	0.41(10.4)	0.90(22.8)	0.87(22.2)	
1	3/4	-U-FL16-FL12	2.38(60.5)	1.23(31.2)	1.50(38.1)	1.37(34.9)	0.62(15.7)	0.96(24.4)	1.13(28.6)	

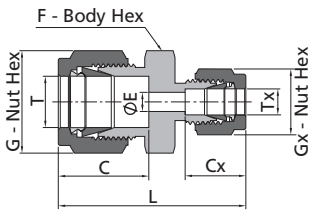

Metric Tube			Dimensions, mm (in.)							
T-Tube O.D. (mm)	Tx-Tube O.D. (mm)	Basic Ordering Number	L	C	G	F	E	Cx	Gx	
3	2	-U-ML3-ML2	35.3(1.39)	12.9(0.51)	12.0(0.47)	12.0(0.47)	1.7(0.07)	12.9(0.51)	12.0(0.47)	
6	2	-U-ML6-ML2	38.6(1.52)	15.3(0.60)	14.0(0.55)	14.0(0.55)	1.7(0.07)	12.9(0.51)	12.0(0.47)	
6	3	-U-ML6-ML3	38.6(1.52)	15.3(0.60)	14.0(0.55)	14.0(0.55)	2.4(0.09)	12.9(0.51)	12.0(0.47)	
6	4	-U-ML6-ML4	39.4(1.55)	15.3(0.60)	14.0(0.55)	14.0(0.55)	2.4(0.09)	13.7(0.54)	12.0(0.47)	
8	6	-U-ML8-ML6	42.3(1.67)	16.3(0.64)	16.0(0.63)	15.0(0.59)	4.8(0.19)	15.3(0.60)	14.0(0.55)	
10	6	-U-ML10-ML6	44.5(1.75)	17.2(0.68)	19.0(0.75)	18.0(0.71)	4.8(0.19)	15.3(0.60)	14.0(0.55)	
10	8	-U-ML10-ML8	45.1(1.78)	17.2(0.68)	19.0(0.75)	18.0(0.71)	6.4(0.25)	16.3(0.64)	16.0(0.63)	
12	6	-U-ML12-ML6	47.0(1.85)	22.8(0.90)	22.0(0.87)	22.0(0.87)	4.8(0.19)	15.3(0.60)	14.0(0.55)	
12	8	-U-ML12-ML8	47.8(1.88)	22.8(0.90)	22.0(0.87)	22.0(0.87)	6.4(0.25)	16.3(0.64)	16.0(0.63)	
12	10	-U-ML12-ML10	48.7(1.92)	22.8(0.90)	22.0(0.87)	22.0(0.87)	7.9(0.31)	17.2(0.68)	19.0(0.75)	
16	10	-U-ML16-ML10	49.5(1.95)	24.4(0.96)	25.0(0.98)	24.0(0.94)	7.9(0.31)	17.2(0.68)	19.0(0.75)	
16	12	-U-ML16-ML12	52.0(2.05)	24.4(0.96)	25.0(0.98)	24.0(0.94)	9.5(0.37)	22.8(0.90)	22.0(0.87)	
18	12	-U-ML18-ML12	53.5(2.11)	24.4(0.96)	30.0(1.18)	27.0(1.06)	9.5(0.37)	22.8(0.90)	22.0(0.87)	
25	18	-U-ML25-ML18	61.0(2.40)	31.3(1.23)	38.0(1.50)	35.0(1.38)	15.1(0.59)	24.4(0.96)	30.0(1.18)	
25	20	-U-ML25-ML20	62.3(2.45)	31.3(1.23)	38.0(1.50)	35.0(1.38)	15.9(0.63)	26.0(1.02)	32.0(1.26)	
30	18	-U-ML30-ML18	75.4(2.97)	39.6(1.56)	50.0(1.97)	46.0(1.81)	15.1(0.59)	24.4(0.96)	30.0(1.18)	
30	20	-U-ML30-ML20	75.4(2.97)	39.6(1.56)	50.0(1.97)	46.0(1.81)	15.9(0.63)	26.0(1.02)	32.0(1.26)	
30	25	-U-ML30-ML25	80.1(3.15)	39.6(1.56)	50.0(1.97)	46.0(1.81)	21.8(0.86)	31.3(1.23)	38.0(1.50)	
32	18	-U-ML32-ML18	77.8(3.06)	42.0(1.65)	50.0(1.97)	46.0(1.81)	15.1(0.59)	24.4(0.96)	30.0(1.18)	
32	20	-U-ML32-ML20	77.8(3.06)	42.0(1.65)	50.0(1.97)	46.0(1.81)	15.9(0.63)	26.0(1.02)	32.0(1.26)	
32	25	-U-ML32-ML25	82.3(3.24)	42.0(1.65)	50.0(1.97)	46.0(1.81)	21.8(0.86)	31.3(1.23)	38.0(1.50)	
38	20	-U-ML38-ML20	87.5(3.44)	49.4(1.94)	60.0(2.36)	55.0(2.17)	15.9(0.63)	26.0(1.02)	32.0(1.26)	
38	25	-U-ML38-ML25	92.0(3.62)	49.4(1.94)	60.0(2.36)	55.0(2.17)	21.8(0.86)	31.3(1.23)	38.0(1.50)	
38	30	-U-ML38-ML30	104.6(4.12)	49.4(1.94)	60.0(2.36)	55.0(2.17)	26.2(1.03)	39.6(1.56)	50.0(1.97)	

Tube Fittings

Bulkhead Unions

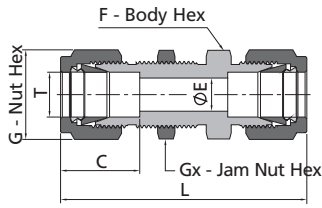

Fractional Tube		Dimensions, in. (mm)							Panel Hole Size in. (mm)	Max. Panel Thickness in. (mm)
Tx-Tube O.D. (in.)	Basic Ordering Number	L	C	E	G	F	Gx			
1/16	-BU-FL1	1.24(31.5)	0.34(8.6)	0.05(1.3)	0.31(7.9)	0.31(7.9)	0.31(7.9)	0.20(5.2)	0.12(3.0)	
1/8	-BU-FL2	2.02(51.3)	0.50(12.7)	0.09(2.3)	0.44(11.1)	0.50(12.7)	0.50(12.7)	0.33(8.3)	0.50(12.7)	
3/16	-BU-FL3	2.11(53.6)	0.54(13.7)	0.12(3.0)	0.50(12.7)	0.56(14.3)	0.56(14.3)	0.39(9.9)	0.50(12.7)	
1/4	-BU-FL4	2.27(57.7)	0.60(15.2)	0.19(4.8)	0.56(14.3)	0.63(15.9)	0.63(15.9)	0.45(11.5)	0.40(10.2)	
5/16	-BU-FL5	2.39(60.7)	0.64(16.3)	0.25(6.4)	0.63(15.9)	0.69(17.5)	0.69(17.5)	0.52(13.1)	0.44(11.2)	
3/8	-BU-FL6	2.45(62.2)	0.66(16.8)	0.28(7.1)	0.69(17.5)	0.75(19.1)	0.75(19.1)	0.58(14.7)	0.44(11.2)	
1/2	-BU-FL8	2.80(71.1)	0.90(22.9)	0.41(10.4)	0.87(22.2)	0.94(23.8)	0.94(23.8)	0.76(19.4)	0.50(12.7)	
5/8	-BU-FL10	2.86(72.6)	0.96(24.4)	0.50(12.7)	1.00(25.4)	1.06(27.0)	1.06(27.0)	0.89(22.6)	0.50(12.7)	
3/4	-BU-FL12	3.11(79.0)	0.96(24.4)	0.62(15.7)	1.13(28.6)	1.19(30.2)	1.19(30.2)	1.02(25.8)	0.66(16.8)	
7/8	-BU-FL14	3.35(85.2)	1.02(25.9)	0.72(18.3)	1.25(31.8)	1.38(34.9)	1.37(34.9)	1.14(29.0)	0.75(19.1)	
1	-BU-FL16	3.77(95.8)	1.23(31.2)	0.88(22.4)	1.50(38.1)	1.63(41.3)	1.63(41.3)	1.33(33.7)	0.75(19.1)	
1 1/4	-BU-FL20	4.85(123.2)	1.62(41.1)	1.09(27.8)	1.87(47.6)	1.87(47.6)	1.87(47.6)	1.64(41.7)	0.75(19.1)	
1 1/2	-BU-FL24	5.48(139.2)	1.97(50.0)	1.34(34.0)	2.25(57.2)	2.25(57.2)	2.25(57.2)	1.95(49.6)	0.75(19.1)	

Metric Tube		Dimensions, mm (in.)							Panel Hole Size mm (in.)	Max. Panel Thickness mm (in.)
Tx-Tube O.D. (mm)	Basic Ordering Number	L	C	E	G	F	Gx			
3	-BU-ML3	51.3(2.02)	12.9(0.51)	2.4(0.09)	12.0(0.47)	14.0(0.55)	14.0(0.55)	8.3(0.33)	12.7(0.50)	
4	-BU-ML4	53.6(2.11)	13.7(0.54)	2.4(0.09)	12.0(0.47)	14.0(0.55)	14.0(0.55)	9.9(0.39)	12.7(0.50)	
6	-BU-ML6	57.7(2.27)	15.3(0.60)	4.8(0.19)	14.0(0.55)	16.0(0.63)	16.0(0.63)	11.5(0.45)	10.2(0.40)	
8	-BU-ML8	61.0(2.40)	16.2(0.64)	6.4(0.25)	16.0(0.63)	18.0(0.71)	18.0(0.71)	13.1(0.52)	11.2(0.44)	
10	-BU-ML10	63.7(2.51)	17.2(0.68)	7.9(0.31)	19.0(0.75)	22.0(0.87)	22.0(0.87)	16.3(0.64)	11.2(0.44)	
12	-BU-ML12	71.0(2.80)	22.8(0.90)	9.5(0.37)	22.0(0.87)	24.0(0.94)	24.0(0.94)	19.5(0.77)	12.7(0.50)	
14	-BU-ML14	72.5(2.85)	24.4(0.96)	11.1(0.44)	25.0(0.98)	27.0(1.06)	27.0(1.06)	22.5(0.89)	12.7(0.50)	
15	-BU-ML15	72.5(2.85)	24.4(0.96)	11.9(0.47)	25.0(0.98)	27.0(1.06)	27.0(1.06)	22.8(0.90)	12.7(0.50)	
16	-BU-ML16	72.5(2.85)	24.4(0.96)	12.7(0.50)	25.0(0.98)	27.0(1.06)	27.0(1.06)	22.8(0.90)	12.7(0.50)	
18	-BU-ML18	78.9(3.11)	24.4(0.96)	15.1(0.59)	30.0(1.18)	30.0(1.18)	30.0(1.18)	26.0(1.02)	16.8(0.66)	
20	-BU-ML20	84.5(3.33)	26.0(1.02)	15.9(0.63)	32.0(1.26)	35.0(1.38)	35.0(1.38)	29.0(1.14)	19.0(0.75)	
25	-BU-ML25	96.0(3.78)	31.3(1.23)	21.8(0.86)	38.0(1.5)	41.0(1.61)	41.0(1.61)	34.0(1.34)	19.0(0.75)	
30	-BU-ML30	124.0(4.88)	39.6(1.56)	26.2(1.03)	50.0(1.97)	50.0(1.97)	50.0(1.97)	40.5(1.59)	19.0(0.75)	
32	-BU-ML32	128.0(5.04)	42.0(1.65)	28.6(1.13)	50.0(1.97)	50.0(1.97)	50.0(1.97)	42.5(1.67)	19.0(0.75)	
38	-BU-ML38	145.0(5.71)	49.4(1.94)	33.7(1.33)	60.0(2.36)	60.0(2.36)	60.0(2.36)	50.5(1.99)	19.0(0.75)	

Bulkhead Reducing Unions

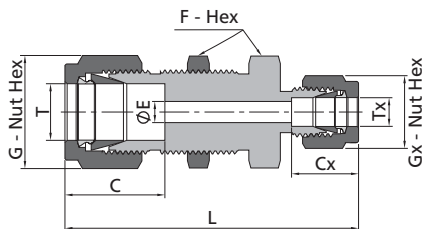

Fractional Tube			Dimensions, in. (mm)							Panel Hole Size in. (mm)	Max. Panel Thickness in. (mm)
T-Tube O.D. (in.)	Tx-Tube O.D. (in.)	Basic Ordering Number	L	C	E	G	F	Cx	Gx		
1/4	1/8	-BU-FL4-FL2	2.17(55.1)	0.60(15.2)	0.09(2.3)	0.56(14.3)	0.63(15.9)	0.50(12.7)	0.44(11.1)	0.45(11.5)	0.40(10.2)
3/8	1/4	-BU-FL6-FL4	2.39(60.7)	0.66(16.8)	0.19(4.8)	0.69(17.5)	0.75(19.1)	0.60(15.2)	0.56(14.3)	0.58(14.7)	0.44(11.2)
1/2	1/4	-BU-FL8-FL4	2.63(66.8)	0.90(22.9)	0.19(4.8)	0.87(22.2)	0.94(23.8)	0.60(15.2)	0.56(14.3)	0.76(19.4)	0.50(12.7)

Bulkhead Reducing Unions

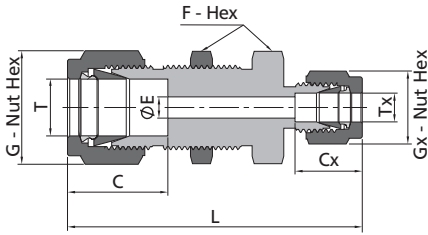

Metric Tube												
T-Tube O.D. (mm)	Tx-Tube O.D. (mm)	Basic Ordering Number	Dimensions, mm (in.)							Panel Hole Size mm (in.)	Max. Panel Thickness mm (in.)	
			L	C	E	G	F	Cx	Gx			
6	3	-BU-ML6-ML3	55.1(2.17)	15.3(0.60)	2.4(0.09)	14.0(0.55)	16.0(0.63)	12.9(0.51)	12.0(0.47)	11.5(0.45)	10.2(0.40)	
8	6	-BU-ML8-ML6	60.1(2.37)	16.2(0.64)	4.8(0.19)	16.0(0.63)	18.0(0.71)	15.3(0.60)	14.0(0.55)	13.1(0.52)	11.2(0.44)	
12	8	-BU-ML12-ML8	67.6(2.66)	22.8(0.90)	6.4(0.25)	22.0(0.87)	24.0(0.94)	16.2(0.64)	16.0(0.63)	19.5(0.77)	12.7(0.50)	

Bulkhead Conversion Unions

Fractional Tube										Metric Tube	
T-Tube O.D. (in.)	Tx-Tube O.D. (mm)	Basic Ordering Number	Dimensions, in. (mm)							Panel Hole Size in. (mm)	Max. Panel Thickness in. (mm)
			L	C	E	G	F	Cx	Gx		
1/4	6	-BU-FL4-ML6	2.27(57.7)	0.60(15.2)	0.19(4.8)	0.56(14.3)	0.63(15.9)	0.60(15.3)	0.55(14.0)	0.45(11.5)	0.40(10.2)

Metric Tube										Fractional Tube	
T-Tube O.D. (mm)	Tx-Tube O.D. (in.)	Basic Ordering Number	Dimensions, mm (in.)							Panel Hole Size mm (in.)	Max. Panel Thickness mm (in.)
			L	C	E	G	F	Cx	Gx		
6	1/8	-BU-ML6-FL2	55.1(2.17)	15.3(0.60)	2.3(0.09)	14.0(0.55)	16.0(0.63)	12.7(0.5)	11.0(0.43)	11.5(0.45)	10.2(0.40)
6	1/4	-BU-ML6-FL4	57.7(2.27)	15.3(0.60)	4.8(0.19)	14.0(0.55)	16.0(0.63)	15.2(0.6)	14.3(0.56)	11.5(0.45)	10.2(0.40)

Bulkhead Locknuts



Fractional Tube	
T-Tube O.D. (in.)	Basic Ordering Number
1/16	-BN-FL1
1/8	-BN-FL2
3/16	-BN-FL3
1/4	-BN-FL4
5/16	-BN-FL5
3/8	-BN-FL6
1/2	-BN-FL8
5/8	-BN-FL10
3/4	-BN-FL12
7/8	-BN-FL14
1	-BN-FL16
1 1/4	-BN-FL20
1 1/2	-BN-FL24

Metric Tube	
T-Tube O.D. (mm)	Basic Ordering Number
3	-BN-ML3
4	-BN-ML4
6	-BN-ML6
8	-BN-ML8
10	-BN-ML10
12	-BN-ML12
14	-BN-ML14
18	-BN-ML18
20	-BN-ML20
22	-BN-ML22
25	-BN-ML25
28	-BN-ML28
30	-BN-ML30
32	-BN-ML32
38	-BN-ML38

A-38 6 Series Tube Fittings

Male Elbows

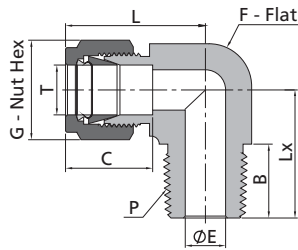

Tube Fittings

Fractional Tube			NPT Thread						
T-Tube O.D. (in.)	P-NPT Size	Basic Ordering Number	Dimensions, in. (mm)						
			L	C	G	F	E	B	Lx
1/16	1/16	-LM-FL1-NS1	0.75(19.1)	0.34(8.6)	0.31(7.9)	0.44(11.1)	0.05(1.3)	0.38(9.7)	0.70(17.8)
1/16	1/8	-LM-FL1-NS2	0.75(19.1)	0.34(8.6)	0.31(7.9)	0.44(11.1)	0.05(1.3)	0.38(9.7)	0.70(17.8)
1/8	1/16	-LM-FL2-NS1	0.93(23.6)	0.50(12.7)	0.44(11.1)	0.44(11.1)	0.09(2.4)	0.38(9.7)	0.70(17.8)
1/8	1/8	-LM-FL2-NS2	0.93(23.6)	0.50(12.7)	0.44(11.1)	0.44(11.1)	0.09(2.4)	0.38(9.7)	0.70(17.8)
1/8	1/4	-LM-FL2-NS4	0.97(24.6)	0.50(12.7)	0.44(11.1)	0.50(12.7)	0.09(2.4)	0.56(14.2)	0.92(23.4)
3/16	1/8	-LM-FL3-NS2	1.00(25.4)	0.54(13.7)	0.50(12.7)	0.50(12.7)	0.12(3.0)	0.38(9.7)	0.74(18.8)
3/16	1/4	-LM-FL3-NS4	1.00(25.4)	0.54(13.7)	0.50(12.7)	0.50(12.7)	0.12(3.0)	0.56(14.2)	0.92(23.4)
1/4	1/16	-LM-FL4-NS1	1.06(26.9)	0.60(15.2)	0.56(14.3)	0.50(12.7)	0.12(3.0)	0.38(9.7)	0.74(18.8)
1/4	1/8	-LM-FL4-NS2	1.06(26.9)	0.60(15.2)	0.56(14.3)	0.50(12.7)	0.19(4.8)	0.38(9.7)	0.74(18.8)
1/4	1/4	-LM-FL4-NS4	1.06(26.9)	0.60(15.2)	0.56(14.3)	0.50(12.7)	0.19(4.8)	0.56(14.2)	0.92(23.4)
1/4	3/8	-LM-FL4-NS6	1.17(29.7)	0.60(15.2)	0.56(14.3)	0.69(17.5)	0.19(4.8)	0.56(14.2)	1.03(26.2)
1/4	1/2	-LM-FL4-NS8	1.25(31.8)	0.60(15.2)	0.56(14.3)	0.81(20.6)	0.19(4.8)	0.75(19.1)	1.30(33.0)
5/16	1/8	-LM-FL5-NS2	1.13(28.7)	0.64(16.3)	0.63(15.9)	0.56(14.3)	0.19(4.8)	0.38(9.7)	0.78(19.8)
5/16	1/4	-LM-FL5-NS4	1.13(28.7)	0.64(16.3)	0.63(15.9)	0.56(14.3)	0.25(6.4)	0.56(14.2)	0.96(24.4)
5/16	3/8	-LM-FL5-NS6	1.20(30.5)	0.64(16.3)	0.63(15.9)	0.69(17.5)	0.25(6.4)	0.56(14.2)	1.03(26.2)
3/8	1/8	-LM-FL6-NS2	1.20(30.5)	0.66(16.8)	0.69(17.5)	0.63(15.9)	0.19(4.8)	0.38(9.7)	0.82(20.8)
3/8	1/4	-LM-FL6-NS4	1.20(30.5)	0.66(16.8)	0.69(17.5)	0.63(15.9)	0.28(7.1)	0.56(14.2)	1.00(25.4)
3/8	3/8	-LM-FL6-NS6	1.23(31.2)	0.66(16.8)	0.69(17.5)	0.69(17.5)	0.28(7.1)	0.56(14.2)	1.03(26.2)
3/8	1/2	-LM-FL6-NS8	1.31(33.3)	0.66(16.8)	0.69(17.5)	0.81(20.6)	0.28(7.1)	0.75(19.1)	1.30(33.0)
3/8	3/4	-LM-FL6-NS12	1.46(37.1)	0.66(16.8)	0.69(17.5)	1.06(27.0)	0.28(7.1)	0.75(19.1)	1.45(36.8)
1/2	1/4	-LM-FL8-NS4	1.42(36.1)	0.90(22.9)	0.87(22.2)	0.81(20.6)	0.28(7.1)	0.56(14.2)	1.11(28.2)
1/2	3/8	-LM-FL8-NS6	1.42(36.1)	0.90(22.9)	0.87(22.2)	0.81(20.6)	0.38(9.7)	0.56(14.2)	1.11(28.2)
1/2	1/2	-LM-FL8-NS8	1.42(36.1)	0.90(22.9)	0.87(22.2)	0.81(20.6)	0.41(10.4)	0.75(19.1)	1.30(33.0)
1/2	3/4	-LM-FL8-NS12	1.57(39.9)	0.90(22.9)	0.87(22.2)	1.06(27.0)	0.41(10.4)	0.75(19.1)	1.45(36.8)
5/8	3/8	-LM-FL10-NS6	1.50(38.1)	0.96(24.4)	1.00(25.4)	0.94(23.8)	0.38(9.7)	0.56(14.2)	1.19(30.2)
5/8	1/2	-LM-FL10-NS8	1.50(38.1)	0.96(24.4)	1.00(25.4)	0.94(23.8)	0.47(11.9)	0.75(19.1)	1.38(35.1)
5/8	3/4	-LM-FL10-NS12	1.57(39.9)	0.96(24.4)	1.00(25.4)	1.06(27.0)	0.50(12.7)	0.75(19.1)	1.45(36.8)
3/4	1/2	-LM-FL12-NS8	1.57(39.9)	0.96(24.4)	1.13(28.6)	1.06(27.0)	0.47(11.9)	0.75(19.1)	1.45(36.8)
3/4	3/4	-LM-FL12-NS12	1.57(39.9)	0.96(24.4)	1.13(28.6)	1.06(27.0)	0.62(15.7)	0.75(19.1)	1.45(36.8)
7/8	3/4	-LM-FL14-NS12	1.76(44.7)	1.02(25.9)	1.25(31.8)	1.37(34.9)	0.62(15.7)	0.75(19.1)	1.64(41.7)
1	3/4	-LM-FL16-NS12	1.93(49.0)	1.23(31.2)	1.50(38.1)	1.37(34.9)	0.62(15.7)	0.75(19.1)	1.64(41.7)
1	1	-LM-FL16-NS16	1.93(49.0)	1.23(31.2)	1.50(38.1)	1.37(34.9)	0.88(22.4)	0.94(23.9)	1.83(46.5)
1 1/4	1 1/4	-LM-FL20-NS20	2.62(66.5)	1.62(41.1)	1.87(47.6)	1.69(42.9)	1.09(27.7)	0.94(23.9)	2.06(52.4)
1 1/2	1 1/2	-LM-FL24-NS24	3.07(78.0)	1.97(50.0)	2.25(57.2)	2.00(50.8)	1.34(34.0)	1.03(26.2)	2.38(60.5)

Fractional Tube			ISO Tapered Thread (RT)						
T-Tube O.D. (in.)	P-RT Size	Basic Ordering Number	Dimensions, in. (mm)						
			L	C	G	F	E	B	Lx
1/8	1/8	-LM-FL2-RT2	0.93(23.6)	0.50(12.7)	0.44(11.1)	0.44(11.1)	0.09(2.4)	0.38(9.7)	0.87(22.2)
1/8	1/4	-LM-FL2-RT4	0.97(24.6)	0.50(12.7)	0.44(11.1)	0.50(12.7)	0.09(2.4)	0.56(14.2)	0.92(23.4)
1/4	1/8	-LM-FL4-RT2	1.06(26.9)	0.60(15.2)	0.56(14.3)	0.50(12.7)	0.19(4.8)	0.38(9.7)	0.74(18.8)
1/4	1/4	-LM-FL4-RT4	1.06(26.9)	0.60(15.2)	0.56(14.3)	0.50(12.7)	0.19(4.8)	0.56(14.2)	0.92(23.4)
1/4	3/8	-LM-FL4-RT6	1.17(29.7)	0.60(15.2)	0.56(14.3)	0.69(17.5)	0.19(4.8)	0.56(14.2)	1.03(26.2)
1/4	1/2	-LM-FL4-RT8	1.25(31.8)	0.60(15.2)	0.56(14.3)	0.81(20.6)	0.19(4.8)	0.75(19.1)	1.30(33.0)
5/16	1/4	-LM-FL5-RT4	1.13(28.7)	0.64(16.3)	0.63(15.9)	0.56(14.3)	0.25(6.4)	0.56(14.2)	0.96(24.4)
3/8	1/8	-LM-FL6-RT2	1.20(30.5)	0.66(16.8)	0.69(17.5)	0.63(15.9)	0.19(4.8)	0.38(9.7)	0.82(20.8)
3/8	1/4	-LM-FL6-RT4	1.20(30.5)	0.66(16.8)	0.69(17.5)	0.63(15.9)	0.28(7.1)	0.56(14.2)	1.00(25.4)
3/8	3/8	-LM-FL6-RT6	1.23(31.2)	0.66(16.8)	0.69(17.5)	0.69(17.5)	0.28(7.1)	0.56(14.2)	1.03(26.2)
1/2	3/8	-LM-FL8-RT6	1.42(36.1)	0.90(22.9)	0.87(22.2)	0.81(20.6)	0.38(9.7)	0.56(14.2)	1.11(28.2)
1/2	1/2	-LM-FL8-RT8	1.42(36.1)	0.90(22.9)	0.87(22.2)	0.81(20.6)	0.41(10.4)	0.75(19.1)	1.30(33.0)
3/4	1/2	-LM-FL12-RT8	1.57(39.9)	0.96(24.4)	1.13(28.6)	1.06(27.0)	0.37(9.5)	0.75(19.1)	1.45(36.8)
1	1	-LM-FL16-RT16	1.93(49.0)	1.23(31.2)	1.50(38.1)	1.37(34.9)	0.88(22.4)	0.94(23.9)	1.83(46.5)

Male Elbows

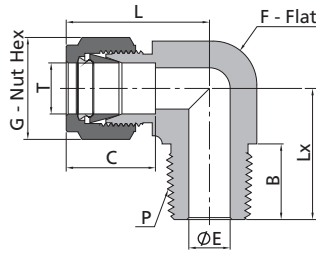

Tube Fittings

Metric Tube			NPT Thread							
T-Tube O.D. (mm)	P-NPT Size	Basic Ordering Number	Dimensions, mm (in.)							
			L	C	G	F	E	B	Lx	
3	1/8	-LM-ML3-NS2	23.6(0.93)	12.9(0.51)	12.0(0.47)	11.1(0.44)	2.4(0.09)	9.7(0.38)	17.8(0.70)	
3	1/4	-LM-ML3-NS4	24.6(0.97)	12.9(0.51)	12.0(0.47)	12.7(0.50)	2.4(0.09)	14.2(0.56)	23.4(0.92)	
4	1/8	-LM-ML4-NS2	25.4(1.00)	13.7(0.54)	12.0(0.47)	12.7(0.50)	2.4(0.09)	9.7(0.38)	18.8(0.74)	
4	1/4	-LM-ML4-NS4	25.4(1.00)	13.7(0.54)	12.0(0.47)	12.7(0.50)	2.4(0.09)	14.2(0.56)	23.4(0.92)	
6	1/8	-LM-ML6-NS2	27.0(1.06)	15.3(0.60)	14.0(0.55)	12.7(0.50)	4.8(0.19)	9.7(0.38)	18.8(0.74)	
6	1/4	-LM-ML6-NS4	27.0(1.06)	15.3(0.60)	14.0(0.55)	12.7(0.50)	4.8(0.19)	14.2(0.56)	23.4(0.92)	
6	3/8	-LM-ML6-NS6	29.8(1.17)	15.3(0.60)	14.0(0.55)	17.5(0.69)	4.8(0.19)	14.2(0.56)	26.2(1.03)	
6	1/2	-LM-ML6-NS8	31.8(1.25)	15.3(0.60)	14.0(0.55)	20.6(0.81)	4.8(0.19)	19.1(0.75)	33.0(1.30)	
8	1/8	-LM-ML8-NS2	28.8(1.13)	16.2(0.64)	16.0(0.63)	14.3(0.56)	4.8(0.19)	9.7(0.38)	19.8(0.78)	
8	1/4	-LM-ML8-NS4	28.8(1.13)	16.2(0.64)	16.0(0.63)	14.3(0.56)	6.4(0.25)	14.2(0.56)	24.4(0.96)	
8	3/8	-LM-ML8-NS6	30.6(1.20)	16.2(0.64)	16.0(0.63)	17.5(0.69)	6.4(0.25)	14.2(0.56)	26.2(1.03)	
8	1/2	-LM-ML8-NS8	32.6(1.28)	16.2(0.64)	16.0(0.63)	20.6(0.81)	6.4(0.25)	19.1(0.75)	33.0(1.30)	
10	1/8	-LM-ML10-NS2	31.5(1.24)	17.2(0.68)	19.0(0.75)	17.5(0.69)	4.8(0.19)	9.7(0.38)	21.6(0.85)	
10	1/4	-LM-ML10-NS4	31.5(1.24)	17.2(0.68)	19.0(0.75)	17.5(0.69)	7.1(0.28)	14.2(0.56)	26.2(1.03)	
10	3/8	-LM-ML10-NS6	31.5(1.24)	17.2(0.68)	19.0(0.75)	17.5(0.69)	7.9(0.31)	14.2(0.56)	26.2(1.03)	
10	1/2	-LM-ML10-NS8	33.5(1.32)	17.2(0.68)	19.0(0.75)	20.6(0.81)	7.9(0.31)	19.1(0.75)	33.0(1.30)	
12	1/8	-LM-ML12-NS2	36.0(1.42)	22.8(0.90)	22.0(0.87)	20.6(0.81)	4.8(0.19)	9.7(0.38)	23.6(0.93)	
12	1/4	-LM-ML12-NS4	36.0(1.42)	22.8(0.90)	22.0(0.87)	20.6(0.81)	7.1(0.28)	14.2(0.56)	28.2(1.11)	
12	3/8	-LM-ML12-NS6	36.0(1.42)	22.8(0.90)	22.0(0.87)	20.6(0.81)	9.5(0.37)	14.2(0.56)	28.2(1.11)	
12	1/2	-LM-ML12-NS8	36.0(1.42)	22.8(0.90)	22.0(0.87)	20.6(0.81)	9.5(0.37)	19.1(0.75)	33.0(1.30)	
12	3/4	-LM-ML12-NS12	39.8(1.57)	22.8(0.90)	22.0(0.87)	27.0(1.06)	9.5(0.37)	19.1(0.75)	36.8(1.45)	
15	1/2	-LM-ML15-NS8	38.0(1.50)	24.4(0.96)	25.0(0.98)	23.8(0.94)	11.9(0.47)	19.1(0.75)	35.1(1.38)	
16	1/4	-LM-ML16-NS4	38.0(1.50)	24.4(0.96)	25.0(0.98)	23.8(0.94)	7.1(0.28)	14.2(0.56)	30.2(1.19)	
16	3/8	-LM-ML16-NS6	38.0(1.50)	24.4(0.96)	25.0(0.98)	23.8(0.94)	9.5(0.37)	14.2(0.56)	30.2(1.19)	
16	1/2	-LM-ML16-NS8	38.0(1.50)	24.4(0.96)	25.0(0.98)	23.8(0.94)	11.9(0.47)	19.1(0.75)	35.1(1.38)	
16	3/4	-LM-ML16-NS12	39.8(1.57)	24.4(0.96)	25.0(0.98)	27.0(1.06)	12.7(0.50)	19.1(0.75)	36.8(1.45)	
18	1/2	-LM-ML18-NS8	39.8(1.57)	24.4(0.96)	30.0(1.18)	27.0(1.06)	11.9(0.47)	19.1(0.75)	36.8(1.45)	
18	3/4	-LM-ML18-NS12	39.8(1.57)	24.4(0.96)	30.0(1.18)	27.0(1.06)	15.1(0.59)	19.1(0.75)	36.8(1.45)	
20	1/2	-LM-ML20-NS8	44.6(1.76)	26.0(1.02)	32.0(1.26)	34.9(1.37)	11.9(0.47)	19.1(0.75)	41.7(1.64)	
20	3/4	-LM-ML20-NS12	44.6(1.76)	26.0(1.02)	32.0(1.26)	34.9(1.37)	15.9(0.63)	19.1(0.75)	41.7(1.64)	
22	3/4	-LM-ML22-NS12	44.6(1.76)	26.0(1.02)	32.0(1.26)	34.9(1.37)	15.9(0.63)	19.1(0.75)	41.7(1.64)	
22	1	-LM-ML22-NS16	44.6(1.76)	26.0(1.02)	32.0(1.26)	34.9(1.37)	18.3(0.72)	23.9(0.94)	46.5(1.83)	
25	3/4	-LM-ML25-NS12	49.1(1.93)	31.3(1.23)	38.0(1.50)	34.9(1.37)	15.9(0.63)	19.1(0.75)	41.7(1.64)	
25	1	-LM-ML25-NS16	49.1(1.93)	31.3(1.23)	38.0(1.50)	34.9(1.37)	21.8(0.86)	23.9(0.94)	46.5(1.83)	
30	1 1/4	-LM-ML30-NS20	69.9(2.75)	39.6(1.56)	50.0(1.97)	42.9(1.69)	26.2(1.03)	23.9(0.94)	53.1(2.09)	
32	1 1/4	-LM-ML32-NS20	72.3(2.85)	42.0(1.65)	50.0(1.97)	42.9(1.69)	27.8(1.09)	23.9(0.94)	53.1(2.09)	
38	1 1/2	-LM-ML38-NS24	84.0(3.31)	49.4(1.94)	60.0(2.36)	50.8(2.00)	33.7(1.33)	26.2(1.03)	60.4(2.38)	

Male Elbows

Tube Fittings

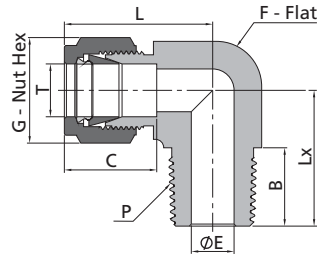

Metric Tube			ISO Tapered Thread (RT)						
T-Tube O.D. (mm)	P-RT Size	Basic Ordering Number	Dimensions, mm (in.)						
			L	C	G	F	E	B	Lx
3	1/8	-LM-ML3-RT2	23.6(0.93)	12.9(0.51)	12.0(0.47)	11.1(0.44)	2.4(0.09)	9.7(0.38)	17.8(0.70)
3	1/4	-LM-ML3-RT4	24.6(0.97)	12.9(0.51)	12.0(0.47)	12.7(0.50)	2.4(0.09)	14.2(0.56)	23.4(0.92)
4	1/8	-LM-ML4-RT2	25.4(1.00)	13.7(0.54)	12.0(0.47)	12.7(0.50)	2.4(0.09)	9.7(0.38)	18.8(0.74)
4	1/4	-LM-ML4-RT4	25.4(1.00)	13.7(0.54)	12.0(0.47)	12.7(0.50)	2.4(0.09)	14.2(0.56)	23.4(0.92)
6	1/8	-LM-ML6-RT2	27.0(1.06)	15.3(0.60)	14.0(0.55)	12.7(0.50)	4.8(0.19)	9.7(0.38)	18.8(0.74)
6	1/4	-LM-ML6-RT4	27.0(1.06)	15.3(0.60)	14.0(0.55)	12.7(0.50)	4.8(0.19)	14.2(0.56)	23.4(0.92)
6	3/8	-LM-ML6-RT6	29.8(1.17)	15.3(0.60)	14.0(0.55)	17.5(0.69)	4.8(0.19)	14.2(0.56)	26.2(1.03)
6	1/2	-LM-ML6-RT8	31.8(1.25)	15.3(0.60)	14.0(0.55)	20.6(0.81)	4.8(0.19)	19.1(0.75)	33.0(1.30)
8	1/8	-LM-ML8-RT2	28.8(1.13)	16.2(0.64)	16.0(0.63)	14.3(0.56)	4.8(0.19)	9.7(0.38)	19.8(0.78)
8	1/4	-LM-ML8-RT4	28.8(1.13)	16.2(0.64)	16.0(0.63)	14.3(0.56)	6.4(0.25)	14.2(0.56)	24.4(0.96)
8	3/8	-LM-ML8-RT6	30.6(1.20)	16.2(0.64)	16.0(0.63)	17.5(0.69)	6.4(0.25)	14.2(0.56)	26.2(1.03)
8	1/2	-LM-ML8-RT8	32.6(1.28)	16.2(0.64)	16.0(0.63)	20.6(0.81)	6.4(0.25)	19.1(0.75)	33.0(1.30)
10	1/8	-LM-ML10-RT2	31.5(1.24)	17.2(0.68)	19.0(0.75)	17.5(0.69)	4.8(0.19)	9.7(0.38)	21.6(0.85)
10	1/4	-LM-ML10-RT4	31.5(1.24)	17.2(0.68)	19.0(0.75)	17.5(0.69)	7.1(0.28)	14.2(0.56)	26.2(1.03)
10	3/8	-LM-ML10-RT6	31.5(1.24)	17.2(0.68)	19.0(0.75)	17.5(0.69)	7.9(0.31)	14.2(0.56)	26.2(1.03)
10	1/2	-LM-ML10-RT8	33.5(1.32)	17.2(0.68)	19.0(0.75)	20.6(0.81)	7.9(0.31)	19.1(0.75)	33.0(1.30)
12	1/8	-LM-ML12-RT2	36.0(1.42)	22.8(0.90)	22.0(0.87)	20.6(0.81)	4.8(0.19)	9.7(0.38)	23.6(0.93)
12	1/4	-LM-ML12-RT4	36.0(1.42)	22.8(0.90)	22.0(0.87)	20.6(0.81)	7.1(0.28)	14.2(0.56)	28.2(1.11)
12	3/8	-LM-ML12-RT6	36.0(1.42)	22.8(0.90)	22.0(0.87)	20.6(0.81)	9.5(0.37)	14.2(0.56)	28.2(1.11)
12	1/2	-LM-ML12-RT8	36.0(1.42)	22.8(0.90)	22.0(0.87)	20.6(0.81)	9.5(0.37)	19.1(0.75)	33.0(1.30)
12	3/4	-LM-ML12-RT12	39.8(1.57)	22.8(0.90)	22.0(0.87)	27.0(1.06)	9.5(0.37)	19.1(0.75)	36.8(1.45)
14	1/2	-LM-ML14-RT8	38.1(1.50)	24.4(0.96)	25.0(0.98)	23.8(0.94)	11.1(0.44)	19.1(0.75)	35.1(1.38)
15	1/2	-LM-ML15-RT8	38.1(1.50)	24.4(0.96)	25.0(0.98)	23.8(0.94)	11.9(0.47)	19.1(0.75)	35.1(1.38)
16	1/4	-LM-ML16-RT4	38.0(1.50)	24.4(0.96)	25.0(0.98)	23.8(0.94)	7.1(0.28)	14.2(0.56)	30.2(1.19)
16	3/8	-LM-ML16-RT6	38.0(1.50)	24.4(0.96)	25.0(0.98)	23.8(0.94)	9.5(0.37)	14.2(0.56)	30.2(1.19)
16	1/2	-LM-ML16-RT8	38.0(1.50)	24.4(0.96)	25.0(0.98)	23.8(0.94)	11.9(0.47)	19.1(0.75)	35.1(1.38)
16	3/4	-LM-ML16-RT12	39.8(1.57)	24.4(0.96)	25.0(0.98)	27.0(1.06)	12.7(0.50)	19.1(0.75)	36.8(1.45)
18	1/2	-LM-ML18-RT8	39.8(1.57)	24.4(0.96)	30.0(1.18)	27.0(1.06)	11.9(0.47)	19.1(0.75)	36.8(1.45)
18	3/4	-LM-ML18-RT12	39.8(1.57)	24.4(0.96)	30.0(1.18)	27.0(1.06)	15.1(0.59)	19.1(0.75)	36.8(1.45)
20	1/2	-LM-ML20-RT8	44.6(1.76)	26.0(1.02)	32.0(1.26)	34.9(1.37)	11.9(0.47)	19.1(0.75)	41.7(1.64)
20	3/4	-LM-ML20-RT12	44.6(1.76)	26.0(1.02)	32.0(1.26)	34.9(1.37)	15.9(0.63)	19.1(0.75)	41.7(1.64)
22	3/4	-LM-ML22-RT12	44.6(1.76)	26.0(1.02)	32.0(1.26)	34.9(1.37)	15.9(0.63)	19.1(0.75)	41.7(1.64)
22	1	-LM-ML22-RT16	44.6(1.76)	26.0(1.02)	32.0(1.26)	34.9(1.37)	18.3(0.72)	23.9(0.94)	46.5(1.83)
25	3/4	-LM-ML25-RT12	49.1(1.93)	31.3(0.90)	38.0(1.50)	34.9(1.37)	15.9(0.63)	19.1(0.75)	41.7(1.64)
25	1	-LM-ML25-RT16	49.1(1.93)	31.3(0.90)	38.0(1.50)	34.9(1.37)	21.8(0.86)	23.9(0.94)	46.5(1.83)
28	1	-LM-ML28-RT16	64.0(2.52)	36.6(0.90)	46.0(1.81)	42.9(1.69)	21.8(0.86)	23.9(0.94)	53.1(2.09)

45° Male Elbows

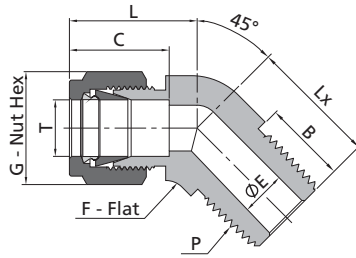

Fractional Tube			NPT Thread						
T-Tube O.D. (in.)	P-NPT Size	Basic Ordering Number	Dimensions, in. (mm)						
			L	C	G	F	E	B	Lx
1/16	1/16	-VM-FL1-NS1	0.62(15.7)	0.34(8.6)	0.31(7.9)	0.37(9.5)	0.05(1.3)	0.38(9.7)	0.57(14.5)
1/8	1/8	-VM-FL2-NS2	0.82(20.8)	0.50(12.7)	0.44(11.1)	0.44(11.1)	0.09(2.3)	0.38(9.7)	0.66(16.8)
3/16	1/8	-VM-FL3-NS2	0.85(21.6)	0.54(13.7)	0.50(12.7)	0.44(11.1)	0.12(3.0)	0.38(9.7)	0.58(14.7)
1/4	1/8	-VM-FL4-NS2	0.97(24.6)	0.60(15.2)	0.56(14.3)	0.50(12.7)	0.19(4.8)	0.38(9.7)	0.65(16.5)
1/4	1/4	-VM-FL4-NS4	0.97(24.6)	0.60(15.2)	0.56(14.3)	0.50(12.7)	0.19(4.8)	0.56(14.2)	0.83(21.1)
5/16	1/8	-VM-FL5-NS2	0.94(24.0)	0.64(16.3)	0.63(15.9)	0.56(14.3)	0.19(4.8)	0.38(9.7)	0.66(16.8)
3/8	1/8	-VM-FL6-NS2	1.10(27.9)	0.66(16.8)	0.69(17.5)	0.63(15.9)	0.19(4.8)	0.38(9.7)	0.72(18.3)
3/8	1/4	-VM-FL6-NS4	1.10(27.9)	0.66(16.8)	0.69(17.5)	0.63(15.9)	0.28(7.1)	0.56(14.2)	0.90(22.9)
3/8	3/8	-VM-FL6-NS6	1.15(29.2)	0.66(16.8)	0.69(17.5)	0.81(20.6)	0.28(7.1)	0.56(14.2)	0.95(24.1)
1/2	3/8	-VM-FL8-NS6	1.26(32.0)	0.90(22.9)	0.87(22.2)	0.81(20.6)	0.38(9.7)	0.56(14.2)	0.95(24.1)
5/8	1/2	-VM-FL10-NS8	1.21(30.7)	0.96(24.4)	1.00(25.4)	0.94(23.8)	0.47(11.9)	0.56(14.2)	1.17(29.7)
3/4	3/4	-VM-FL12-NS12	1.34(34.0)	0.96(24.4)	1.13(28.6)	1.06(27.0)	0.62(15.7)	0.75(19.1)	1.22(31.0)
7/8	3/4	-VM-FL14-NS12	1.59(40.4)	1.02(25.9)	1.25(31.8)	1.25(31.8)	0.62(15.7)	0.75(19.1)	1.27(32.3)
1	1	-VM-FL16-NS16	1.59(40.4)	1.23(31.2)	1.50(38.1)	1.37(34.9)	0.88(22.4)	0.94(23.9)	1.49(37.8)

Metric Tube			NPT Thread						
T-Tube O.D. (mm)	P-NPT Size	Basic Ordering Number	Dimensions, mm (in.)						
			L	C	G	F	E	B	Lx
6	1/8	-VM-ML6-NS2	23.4(0.92)	15.3(0.60)	14.0(0.55)	12.7(0.50)	4.8(0.19)	9.7(0.38)	16.8(0.66)
6	1/4	-VM-ML6-NS4	23.4(0.92)	15.3(0.60)	14.0(0.55)	12.7(0.50)	4.8(0.19)	14.2(0.56)	21.8(0.86)
8	1/8	-VM-ML8-NS2	24.3(0.96)	16.2(0.64)	16.0(0.63)	15.9(0.63)	4.8(0.19)	9.7(0.38)	16.8(0.66)
10	1/4	-VM-ML10-NS4	26.6(1.05)	17.2(0.68)	19.0(0.75)	17.5(0.69)	7.9(0.31)	14.2(0.56)	24.1(0.95)
12	3/8	-VM-ML12-NS6	29.1(1.15)	22.8(0.90)	22.0(0.87)	20.6(0.81)	9.5(0.37)	14.2(0.56)	24.1(0.95)
12	1/2	-VM-ML12-NS8	30.7(1.21)	22.8(0.90)	22.0(0.87)	20.6(0.81)	9.5(0.37)	19.1(0.75)	29.7(1.17)
16	1/2	-VM-ML16-NS8	30.7(1.21)	24.4(0.96)	25.0(0.98)	23.8(0.94)	11.9(0.47)	19.1(0.75)	29.7(1.17)

Adjustable Male Elbows

SAE/MS Straight Thread

Adapt to straight thread boss of SAE J1926-1, ISO 11926-1 and MS 16142.

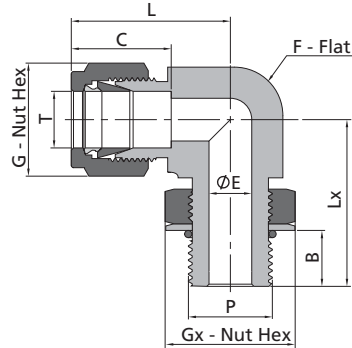

Fractional Tube			SAE/MS Straight Thread							
T-Tube O.D. (in.)	P-SAE/MS Thread Size	Basic Ordering Number	Dimensions, in. (mm)							
			L	B	C	G	E	F	Lx	Gx
1/4	7/16-20	-LP-FL4-ST7	1.12(28.4)	0.39(9.9)	0.60(15.2)	0.56(14.3)	0.19(4.8)	0.50(12.7)	1.06(27.0)	0.56(14.3)
1/4	9/16-18	-LP-FL4-ST9	1.20(30.5)	0.44(11.2)	0.60(15.2)	0.56(14.3)	0.19(4.8)	0.63(15.9)	1.27(32.3)	0.69(17.5)
5/16	1/2-20	-LP-FL5-ST8	1.19(30.2)	0.39(9.9)	0.64(16.3)	0.63(15.9)	0.23(5.8)	0.56(14.3)	1.16(29.5)	0.63(15.9)
3/8	7/16-20	-LP-FL6-ST7	1.31(33.3)	0.39(9.9)	0.66(16.8)	0.69(17.5)	0.20(5.1)	0.63(15.9)	1.24(31.5)	0.56(14.3)
3/8	9/16-18	-LP-FL6-ST9	1.26(32.0)	0.44(11.2)	0.66(16.8)	0.69(17.5)	0.28(7.1)	0.63(15.9)	1.27(32.3)	0.69(17.5)
3/8	3/4-16	-LP-FL6-ST12	1.37(34.8)	0.50(12.7)	0.66(16.8)	0.69(17.5)	0.28(7.1)	0.81(20.6)	1.49(37.8)	0.87(22.2)
1/2	9/16-18	-LP-FL8-ST9	1.48(37.6)	0.44(11.2)	0.90(22.9)	0.87(22.2)	0.28(7.1)	0.81(20.6)	1.48(37.5)	0.69(17.5)
1/2	3/4-16	-LP-FL8-ST12	1.48(37.6)	0.50(12.7)	0.90(22.9)	0.87(22.2)	0.41(10.4)	0.81(20.6)	1.49(37.8)	0.87(22.2)
5/8	7/8-14	-LP-FL10-ST14	1.56(39.6)	0.56(14.2)	0.96(24.4)	1.00(25.4)	0.50(12.7)	0.94(23.8)	1.71(43.4)	1.00(25.4)
3/4	1 1/16-12	-LP-FL12-ST17	1.63(41.4)	0.66(16.8)	0.96(24.4)	1.13(28.6)	0.62(15.7)	1.06(27.0)	1.92(48.8)	1.25(31.8)
7/8	1 3/16-12	-LP-FL14-ST19	1.70(43.2)	0.66(16.8)	1.02(25.9)	1.25(31.8)	0.72(18.3)	1.19(30.2)	1.99(50.5)	1.37(34.9)
1	1 5/16-12	-LP-FL16-ST21	1.99(50.5)	0.66(16.8)	1.23(31.2)	1.50(38.1)	0.88(22.4)	1.37(34.9)	2.11(53.6)	1.50(38.1)
1 1/4	1 5/8-12	-LP-FL20-ST26	2.67(67.8)	0.66(16.8)	1.62(41.1)	1.87(47.6)	1.09(27.7)	1.69(42.9)	2.29(58.2)	1.87(47.6)
1 1/2	1 7/8-12	-LP-FL24-ST30	3.07(78.0)	0.66(16.8)	1.97(50.0)	2.25(57.2)	1.34(34.0)	2.00(50.8)	2.38(60.5)	2.13(54.0)

Adjustable Male Elbows

ISO Parallel Thread

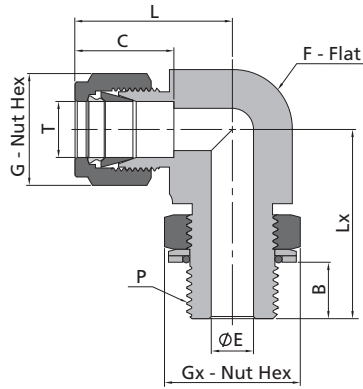

Tube Fittings

Fractional Tube			ISO Parallel Thread (PP)							
T-Tube O.D. (in.)	P-ISO Parallel Thread Size	Basic Ordering Number	Dimensions, in. (mm)							
			L	B	C	G	E	F	Lx	Gx
1/4	1/8	-LP-FL4-PP2	1.06(26.9)	0.26(6.6)	0.60(15.2)	0.56(14.3)	0.16(4.1)	0.50(12.7)	1.04(26.4)	0.56(14.3)
1/4	1/4	-LP-FL4-PP4	1.14(29.0)	0.35(9.0)	0.60(15.2)	0.56(14.3)	0.19(4.8)	0.63(15.9)	1.27(32.3)	0.75(19.1)
3/8	1/4	-LP-FL6-PP4	1.20(30.5)	0.35(9.0)	0.66(16.8)	0.69(17.5)	0.23(5.8)	0.63(15.9)	1.27(32.3)	0.75(19.1)
3/8	3/8	-LP-FL6-PP6	1.31(33.3)	0.37(9.4)	0.66(16.8)	0.69(17.5)	0.28(7.1)	0.81(20.6)	1.46(37.1)	0.87(22.2)
1/2	1/4	-LP-FL8-PP4	1.42(36.1)	0.35(9.0)	0.90(22.9)	0.87(22.2)	0.23(5.8)	0.81(20.6)	1.38(35.1)	0.75(19.1)
1/2	3/8	-LP-FL8-PP6	1.42(36.1)	0.37(9.4)	0.90(22.9)	0.87(22.2)	0.31(7.9)	0.81(20.6)	1.46(37.1)	0.87(22.2)
1/2	1/2	-LP-FL8-PP8	1.50(38.1)	0.51(13.0)	0.90(22.9)	0.87(22.2)	0.41(10.4)	0.94(23.8)	1.71(43.4)	1.06(27.0)
5/8	1/2	-LP-FL10-PP8	1.50(38.1)	0.51(13.0)	0.96(24.4)	1.00(25.4)	0.47(11.9)	0.94(23.8)	1.71(43.4)	1.06(27.0)
3/4	1/2	-LP-FL12-PP8	1.57(39.9)	0.51(13.0)	0.96(24.4)	1.13(28.6)	0.47(11.9)	1.06(27.0)	1.78(45.2)	1.06(27.0)
3/4	3/4	-LP-FL12-PP12	1.57(39.9)	0.51(13.0)	0.96(24.4)	1.13(28.6)	0.62(15.7)	1.06(27.0)	1.92(48.8)	1.37(34.9)
1	3/4	-LP-FL16-PP12	1.93(49.0)	0.51(13.0)	1.23(31.2)	1.50(38.1)	0.62(15.7)	1.37(34.9)	2.10(53.3)	1.37(34.9)
1	1	-LP-FL16-PP16	1.93(49.0)	0.52(13.2)	1.23(31.2)	1.50(38.1)	0.78(19.8)	1.37(34.9)	2.11(53.6)	1.63(41.3)

Metric Tube			ISO Parallel Thread (PP)							
T-Tube O.D. (mm)	P-ISO Parallel Thread Size	Basic Ordering Number	Dimensions, mm (in.)							
			L	B	C	G	E	F	Lx	Gx
6	1/8	-LP-ML6-PP2	27.0(1.06)	6.6(0.26)	15.3(0.60)	14.0(0.55)	4.0(0.16)	12.7(0.50)	26.4(1.04)	14.3(0.56)
6	1/4	-LP-ML6-PP4	29.0(1.14)	9.0(0.35)	15.3(0.60)	14.0(0.55)	4.8(0.19)	15.9(0.63)	32.3(1.27)	19.1(0.75)
8	1/8	-LP-ML8-PP2	28.8(1.13)	6.6(0.26)	16.2(0.64)	16.0(0.63)	4.0(0.16)	14.3(0.56)	27.4(1.08)	14.3(0.56)
8	1/4	-LP-ML8-PP4	29.9(1.18)	9.0(0.35)	16.2(0.64)	16.0(0.63)	5.9(0.23)	15.9(0.63)	32.2(1.27)	19.1(0.75)
10	1/4	-LP-ML10-PP4	33.5(1.32)	9.0(0.35)	17.2(0.68)	19.0(0.75)	5.9(0.23)	20.6(0.81)	35.0(1.38)	19.1(0.75)
10	3/8	-LP-ML10-PP6	33.5(1.32)	9.4(0.37)	17.2(0.68)	19.0(0.75)	7.9(0.31)	20.6(0.81)	37.1(1.46)	22.2(0.87)
12	1/4	-LP-ML12-PP4	36.0(1.42)	9.0(0.35)	22.8(0.90)	22.0(0.87)	5.9(0.23)	20.6(0.81)	35.0(1.38)	19.1(0.75)
12	3/8	-LP-ML12-PP6	36.0(1.42)	9.4(0.37)	22.8(0.90)	22.0(0.87)	7.9(0.31)	20.6(0.81)	37.1(1.46)	22.2(0.87)
12	1/2	-LP-ML12-PP8	38.0(1.50)	13.0(0.51)	22.8(0.90)	22.0(0.87)	9.5(0.37)	23.8(0.94)	43.4(1.71)	27.0(1.06)
12	3/4	-LP-ML12-PP12	39.8(1.57)	13.0(0.51)	22.8(0.90)	22.0(0.87)	9.5(0.37)	27.0(1.06)	48.8(1.92)	34.9(1.37)

A-44 6 Series Tube Fittings

45° Adjustable Male Elbows

SAE/MS Straight Thread

Adapt to straight thread boss of SAE J1926-1, ISO 11926-1 and MS 16142.

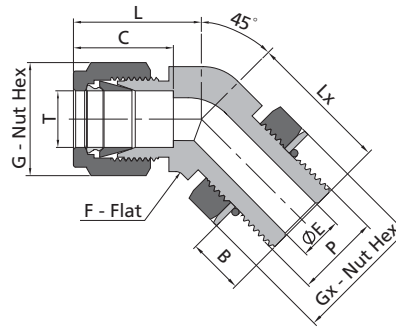

Fractional Tube			SAE/MS Straight Thread							
T-Tube O.D. (in.)	P-SAE/MS Thread Size	Basic Ordering Number	Dimensions, in. (mm)							
			L	B	C	G	E	F	Lx	Gx
1/4	7/16-20	-VP-FL4-ST7	1.01(25.7)	0.39(9.9)	0.60(15.2)	0.56(14.3)	0.19(4.8)	0.50(12.7)	1.01(25.7)	0.56(14.3)
3/8	9/16-18	-VP-FL6-ST9	1.10(27.9)	0.44(11.2)	0.66(16.8)	0.69(17.5)	0.28(7.1)	0.63(15.9)	1.11(28.2)	0.69(17.5)
1/2	3/4-16	-VP-FL8-ST12	1.26(32.0)	0.50(12.7)	0.90(22.9)	0.87(22.2)	0.41(10.4)	0.81(20.6)	1.27(32.3)	0.87(22.2)
3/4	1 1/16-12	-VP-FL12-ST17	1.57(39.9)	0.66(16.8)	0.96(24.4)	1.13(28.6)	0.62(15.7)	1.06(27.0)	1.86(47.2)	1.25(31.8)
1	1 5/16-12	-VP-FL16-ST21	1.87(47.5)	0.66(16.8)	1.23(31.2)	1.50(38.1)	0.88(22.4)	1.37(34.9)	1.99(50.5)	1.50(38.1)

Female Elbows

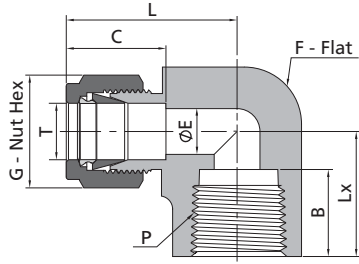

Tube Fittings

Fractional Tube			NPT Thread						
T-Tube O.D. (in.)	P-NPT Size	Basic Ordering Number	Dimensions, in. (mm)						
			L	B	C	G	E	F	Lx
1/16	1/16	-LF-FL1-NS1	0.71(18.0)	0.39(9.9)	0.34(8.6)	0.31(7.9)	0.05(1.3)	0.44(11.1)	0.56(14.2)
1/16	1/8	-LF-FL1-NS2	0.81(20.6)	0.41(10.4)	0.34(8.6)	0.31(7.9)	0.05(1.3)	0.56(14.3)	0.75(19.1)
1/8	1/8	-LF-FL2-NS2	0.97(24.6)	0.41(10.4)	0.50(12.7)	0.44(11.1)	0.09(2.3)	0.50(12.7)	0.75(19.1)
1/8	1/4	-LF-FL2-NS4	1.08(27.4)	0.59(15.0)	0.50(12.7)	0.44(11.1)	0.09(2.3)	0.69(17.5)	0.88(22.4)
3/16	1/8	-LF-FL3-NS2	1.00(25.4)	0.41(10.4)	0.54(13.7)	0.50(12.7)	0.12(3.0)	0.5(12.7)	0.75(19.1)
1/4	1/8	-LF-FL4-NS2	1.06(26.9)	0.41(10.4)	0.60(15.2)	0.56(14.3)	0.19(4.8)	0.50(12.7)	0.75(19.1)
1/4	1/4	-LF-FL4-NS4	1.17(29.7)	0.59(15.0)	0.60(15.2)	0.56(14.3)	0.19(4.8)	0.69(17.5)	0.88(22.4)
1/4	3/8	-LF-FL4-NS6	1.25(31.8)	0.59(15.0)	0.60(15.2)	0.56(14.3)	0.19(4.8)	0.81(20.6)	0.88(22.4)
1/4	1/2	-LF-FL4-NS8	1.36(34.5)	0.78(19.8)	0.60(15.2)	0.56(14.3)	0.19(4.8)	1.00(25.4)	1.12(28.4)
5/16	1/8	-LF-FL5-NS2	1.13(28.7)	0.41(10.4)	0.64(16.3)	0.63(15.9)	0.25(6.4)	0.56(14.3)	0.75(19.1)
5/16	1/4	-LF-FL5-NS4	1.20(30.5)	0.59(15.0)	0.64(16.3)	0.63(15.9)	0.25(6.4)	0.69(17.5)	0.88(22.4)
3/8	1/8	-LF-FL6-NS2	1.20(30.5)	0.41(10.4)	0.66(16.8)	0.69(17.5)	0.28(7.1)	0.63(15.9)	0.75(19.1)
3/8	1/4	-LF-FL6-NS4	1.23(31.2)	0.59(15.0)	0.66(16.8)	0.69(17.5)	0.28(7.1)	0.69(17.5)	0.88(22.4)
3/8	3/8	-LF-FL6-NS6	1.31(33.3)	0.59(15.0)	0.66(16.8)	0.69(17.5)	0.28(7.1)	0.81(20.6)	0.88(22.4)
3/8	1/2	-LF-FL6-NS8	1.42(36.1)	0.78(19.8)	0.66(16.8)	0.69(17.5)	0.28(7.1)	1.00(25.4)	1.12(28.4)
1/2	1/4	-LF-FL8-NS4	1.42(36.1)	0.59(15.0)	0.90(22.9)	0.87(22.2)	0.41(10.4)	0.81(20.6)	0.88(22.4)
1/2	3/8	-LF-FL8-NS6	1.42(36.1)	0.59(15.0)	0.90(22.9)	0.87(22.2)	0.41(10.4)	0.81(20.6)	0.88(22.4)
1/2	1/2	-LF-FL8-NS8	1.53(38.9)	0.78(19.8)	0.90(22.9)	0.87(22.2)	0.41(10.4)	1.00(25.4)	1.12(28.4)
5/8	3/8	-LF-FL10-NS6	1.50(38.1)	0.59(15.0)	0.96(24.4)	1.00(25.4)	0.50(12.7)	0.94(23.8)	0.88(22.4)
5/8	1/2	-LF-FL10-NS8	1.57(39.9)	0.78(19.8)	0.96(24.4)	1.00(25.4)	0.50(12.7)	1.06(27.0)	1.12(28.4)
3/4	1/2	-LF-FL12-NS8	1.57(39.9)	0.78(19.8)	0.96(24.4)	1.13(28.6)	0.62(15.7)	1.06(27.0)	1.12(28.4)
3/4	3/4	-LF-FL12-NS12	1.76(44.7)	0.81(20.6)	0.96(24.4)	1.13(28.6)	0.62(15.7)	1.37(34.9)	1.25(31.8)
7/8	3/4	-LF-FL14-NS12	1.76(44.7)	0.81(20.6)	1.02(25.9)	1.25(31.8)	0.72(18.3)	1.37(34.9)	1.25(31.8)
1	3/4	-LF-FL16-NS12	1.93(49.0)	0.81(20.6)	1.23(31.2)	1.50(38.1)	0.88(22.4)	1.37(34.9)	1.25(31.8)
1	1	-LF-FL16-NS16	2.11(53.6)	1.06(26.9)	1.23(31.2)	1.50(38.1)	0.88(22.4)	1.69(42.9)	1.50(38.1)

Metric Tube			NPT Thread						
T-Tube O.D. (mm)	P-NPT Size	Basic Ordering Number	Dimensions, mm (in.)						
			L	B	C	G	E	F	Lx
6	1/8	-LF-ML6-NS2	27.0(1.06)	10.4(0.41)	15.3(0.60)	14.0(0.55)	4.8(0.19)	12.7(0.50)	19.0(0.75)
6	1/4	-LF-ML6-NS4	29.8(1.17)	15.0(0.59)	15.3(0.60)	14.0(0.55)	4.8(0.19)	17.5(0.69)	22.4(0.88)
8	1/8	-LF-ML8-NS2	28.8(1.13)	10.4(0.41)	16.2(0.64)	16.0(0.63)	6.4(0.25)	14.3(0.56)	19.1(0.75)
8	1/4	-LF-ML8-NS4	30.6(1.20)	15.0(0.59)	16.2(0.64)	16.0(0.63)	6.4(0.25)	17.5(0.69)	22.4(0.88)
10	1/4	-LF-ML10-NS4	33.5(1.32)	15.0(0.59)	17.2(0.68)	19.0(0.75)	7.9(0.31)	20.6(0.81)	22.4(0.88)
10	3/8	-LF-ML10-NS6	33.5(1.32)	15.0(0.59)	17.2(0.68)	19.0(0.75)	7.9(0.31)	20.6(0.81)	22.4(0.88)
10	1/2	-LF-ML10-NS8	36.6(1.44)	19.8(0.78)	17.2(0.68)	19.0(0.75)	7.9(0.31)	25.4(1.00)	28.5(1.12)
12	1/4	-LF-ML12-NS4	36.0(1.42)	15.0(0.59)	22.8(0.90)	22.0(0.87)	9.5(0.37)	20.6(0.81)	22.4(0.88)
12	3/8	-LF-ML12-NS6	36.0(1.42)	15.0(0.59)	22.8(0.90)	22.0(0.87)	9.5(0.37)	20.6(0.81)	22.4(0.88)
12	1/2	-LF-ML12-NS8	38.8(1.53)	19.8(0.78)	22.8(0.90)	22.0(0.87)	9.5(0.37)	25.4(1.00)	28.4(1.12)
16	3/8	-LF-ML16-NS6	39.5(1.56)	15.0(0.59)	24.4(0.96)	25.0(0.98)	12.7(0.50)	27.0(1.06)	23.6(0.93)
16	1/2	-LF-ML16-NS8	39.5(1.56)	19.8(0.78)	24.4(0.96)	25.0(0.98)	12.7(0.50)	27.0(1.06)	28.5(1.12)

Union Elbows

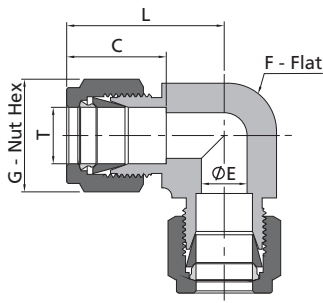

Tube Fittings

Fractional Tube						
T-Tube O.D. (in.)	Basic Ordering Number	Dimensions, in. (mm)				
		L	C	G	F	E
1/16	-LU-FL1	0.70(17.8)	0.34(8.6)	0.31(7.9)	0.37(9.5)	0.05(1.3)
1/8	-LU-FL2	0.88(22.4)	0.50(12.7)	0.44(11.1)	0.37(9.5)	0.09(2.3)
3/16	-LU-FL3	1.00(25.4)	0.54(13.7)	0.50(12.7)	0.50(12.7)	0.12(3.0)
1/4	-LU-FL4	1.06(26.9)	0.60(15.2)	0.56(14.3)	0.50(12.7)	0.19(4.8)
5/16	-LU-FL5	1.13(28.7)	0.64(16.3)	0.63(15.9)	0.56(14.3)	0.25(6.4)
3/8	-LU-FL6	1.20(30.5)	0.66(16.8)	0.69(17.5)	0.63(15.9)	0.28(7.1)
1/2	-LU-FL8	1.42(36.1)	0.90(22.9)	0.87(22.2)	0.81(20.6)	0.41(10.4)
5/8	-LU-FL10	1.50(38.1)	0.96(24.4)	1.00(25.4)	0.94(23.8)	0.5(12.7)
3/4	-LU-FL12	1.57(39.9)	0.96(24.4)	1.13(28.6)	1.06(27.0)	0.62(15.7)
7/8	-LU-FL14	1.76(44.7)	1.02(25.9)	1.25(31.8)	1.37(34.9)	0.72(18.3)
1	-LU-FL16	1.93(49.0)	1.23(31.2)	1.50(38.1)	1.37(34.9)	0.88(22.4)
1 1/8	-LU-FL18	2.63(66.9)	1.44(36.7)	1.75(44.5)	1.69(42.9)	0.97(24.6)
1 1/4	-LU-FL20	2.62(66.5)	1.62(41.1)	1.87(47.6)	1.69(42.9)	1.09(27.7)
1 1/2	-LU-FL24	3.07(78.0)	1.97(50.0)	2.25(57.2)	2.00(50.8)	1.34(34.0)

Metric Tube						
T-Tube O.D. (mm)	Basic Ordering Number	Dimensions, mm (in.)				
		L	C	G	F	E
3	-LU-ML3	22.3(0.88)	12.9(0.51)	12.0(0.47)	9.5(0.37)	2.4(0.09)
4	-LU-ML4	25.4(1.00)	13.7(0.54)	12.0(0.47)	12.7(0.50)	2.4(0.09)
6	-LU-ML6	27.0(1.06)	15.3(0.60)	14.0(0.55)	12.7(0.50)	4.8(0.19)
8	-LU-ML8	28.8(1.13)	16.2(0.64)	16.0(0.63)	14.3(0.56)	6.4(0.25)
10	-LU-ML10	31.5(1.24)	17.2(0.68)	19.0(0.75)	17.5(0.69)	7.9(0.31)
12	-LU-ML12	36.0(1.42)	22.8(0.90)	22.0(0.87)	20.6(0.81)	9.5(0.37)
14	-LU-ML14	38.0(1.50)	24.4(0.96)	25.0(0.98)	23.8(0.94)	11.0(0.43)
15	-LU-ML15	38.0(1.50)	24.4(0.96)	25.0(0.98)	23.8(0.94)	11.9(0.47)
16	-LU-ML16	38.0(1.50)	24.4(0.96)	25.0(0.98)	23.8(0.94)	12.7(0.50)
18	-LU-ML18	39.8(1.57)	24.4(0.96)	30.0(1.18)	27.0(1.06)	15.1(0.59)
20	-LU-ML20	44.6(1.76)	26.0(1.02)	32.0(1.26)	34.9(1.37)	15.9(0.63)
22	-LU-ML22	44.6(1.76)	26.0(1.02)	32.0(1.26)	34.9(1.37)	18.3(0.72)
25	-LU-ML25	49.1(1.93)	31.3(1.23)	38.0(1.5)	34.9(1.37)	21.8(0.86)
28	-LU-ML28	64.0(2.52)	36.6(1.44)	46.0(1.81)	42.9(1.69)	21.8(0.86)
30	-LU-ML30	69.9(2.75)	39.6(1.56)	50.0(1.97)	42.9(1.69)	26.2(1.03)
32	-LU-ML32	72.3(2.85)	42.0(1.65)	50.0(1.97)	42.9(1.69)	28.6(1.13)
38	-LU-ML38	84.0(3.31)	49.4(1.94)	60.0(2.36)	50.8(2.00)	33.7(1.33)

Union Reducing Elbows

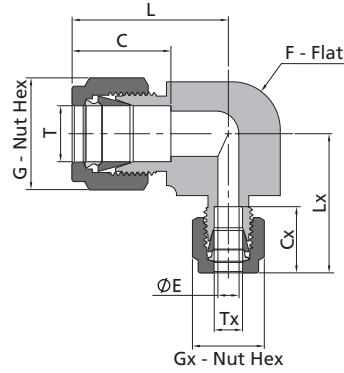

Tube Fittings

Fractional Tube			Dimensions, in. (mm)							
T-Tube O.D. (in.)	Tx-Tube O.D. (in.)	Basic Ordering Number	L	C	G	F	E	Cx	Gx	Lx
3/16	1/8	-LU-FL3-FL2	1.00(25.4)	0.54(13.7)	0.50(12.7)	0.50(12.7)	0.09(2.3)	0.50(12.7)	0.44(11.1)	0.97(24.7)
1/4	1/8	-LU-FL4-FL2	1.06(26.9)	0.60(15.2)	0.56(14.3)	0.50(12.7)	0.09(2.3)	0.50(12.7)	0.44(11.1)	1.00(25.4)
5/16	1/8	-LU-FL5-FL2	1.17(29.7)	0.64(16.3)	0.63(15.9)	0.56(14.3)	0.09(2.3)	0.50(12.7)	0.44(11.1)	1.04(26.4)
5/16	1/4	-LU-FL5-FL4	1.17(29.7)	0.64(16.3)	0.63(15.9)	0.56(14.3)	0.19(4.8)	0.60(15.2)	0.56(14.3)	1.14(29.0)
3/8	1/8	-LU-FL6-FL2	1.20(30.5)	0.66(16.8)	0.69(17.5)	0.63(15.9)	0.09(2.3)	0.50(12.7)	0.44(11.1)	1.04(26.4)
3/8	1/4	-LU-FL6-FL4	1.20(30.5)	0.66(16.8)	0.69(17.5)	0.63(15.9)	0.19(4.8)	0.60(15.2)	0.56(14.3)	1.14(29.0)
3/8	5/16	-LU-FL6-FL5	1.20(30.5)	0.66(16.8)	0.69(17.5)	0.63(15.9)	0.25(6.4)	0.64(16.3)	0.63(15.9)	1.17(29.7)
1/2	1/4	-LU-FL8-FL4	1.42(36.1)	0.90(22.9)	0.87(22.2)	0.81(20.6)	0.19(4.8)	0.60(15.2)	0.56(14.3)	1.27(32.2)
1/2	5/16	-LU-FL8-FL5	1.42(36.1)	0.90(22.9)	0.87(22.2)	0.81(20.6)	0.25(6.4)	0.64(16.3)	0.63(15.9)	1.28(32.5)
1/2	3/8	-LU-FL8-FL6	1.42(36.1)	0.90(22.9)	0.87(22.2)	0.81(20.6)	0.28(7.1)	0.66(16.8)	0.69(17.5)	1.32(33.6)
5/8	3/8	-LU-FL10-FL6	1.50(38.1)	0.96(24.4)	1.00(25.4)	0.94(23.8)	0.28(7.1)	0.66(16.8)	0.69(17.5)	1.40(35.6)
5/8	1/2	-LU-FL10-FL8	1.50(38.1)	0.96(24.4)	1.00(25.4)	0.94(23.8)	0.41(10.4)	0.90(22.9)	0.87(22.2)	1.50(38.1)
3/4	1/4	-LU-FL12-FL4	1.57(39.9)	0.96(24.4)	1.13(28.6)	1.06(27.0)	0.19(4.8)	0.60(15.2)	0.56(14.3)	1.41(35.9)
3/4	3/8	-LU-FL12-FL6	1.57(39.9)	0.96(24.4)	1.13(28.6)	1.06(27.0)	0.28(7.1)	0.66(16.8)	0.69(17.5)	1.47(37.4)
3/4	1/2	-LU-FL12-FL8	1.57(39.9)	0.96(24.4)	1.13(28.6)	1.06(27.0)	0.41(10.4)	0.90(22.9)	0.87(22.2)	1.57(39.9)
7/8	1/4	-LU-FL14-FL4	1.76(44.7)	1.02(25.9)	1.25(31.8)	1.37(34.9)	0.19(4.8)	0.60(15.2)	0.56(14.3)	1.60(40.7)
1	1/2	-LU-FL16-FL8	1.93(49.0)	1.23(31.2)	1.50(38.1)	1.37(34.9)	0.41(10.4)	0.90(22.9)	0.87(22.2)	1.75(44.4)
1	3/4	-LU-FL16-FL12	1.93(49.0)	1.23(31.2)	1.50(38.1)	1.37(34.9)	0.62(15.7)	0.96(24.4)	1.13(28.6)	1.85(47.1)

Metric Tube			Dimensions, mm (in.)							
T-Tube O.D. (mm)	Tx-Tube O.D. (mm)	Basic Ordering Number	L	C	G	F	E	Cx	Gx	Lx
8	6	-LU-ML8-ML6	28.8(1.13)	16.2(0.64)	16.0(0.63)	14.3(0.56)	4.8(0.19)	15.3(0.60)	14.0(0.55)	27.9(1.10)
10	8	-LU-ML10-ML8	31.5(1.24)	17.2(0.68)	19.0(0.75)	17.5(0.69)	6.4(0.25)	16.2(0.64)	16.0(0.63)	30.5(1.20)
12	8	-LU-ML12-ML8	36.0(1.42)	22.8(0.90)	22.0(0.87)	20.6(0.81)	6.4(0.25)	16.2(0.64)	16.0(0.63)	32.6(1.28)
14	8	-LU-ML14-ML8	38.8(1.53)	24.4(0.96)	25.0(0.98)	23.8(0.94)	6.4(0.25)	16.2(0.64)	16.0(0.63)	34.7(1.37)
14	10	-LU-ML14-ML10	38.8(1.53)	24.4(0.96)	25.0(0.98)	23.8(0.94)	7.9(0.31)	17.2(0.68)	19.0(0.75)	35.5(1.40)

Bulkhead Union Elbows

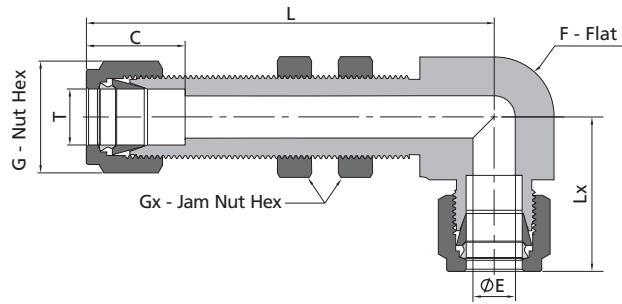

Fractional Tube		Dimensions, in. (mm)							Panel Hole Size in. (mm)	Max. Panel Thickness in. (mm)
T-Tube O.D. (in.)	Basic Ordering Number	L	C	E	G	F	LX	Gx		
1/8	-BBLU-FL2	1.93(49.0)	0.50(12.7)	0.09(2.3)	0.44(11.1)	0.37(9.5)	0.88(22.4)	0.50(12.7)	0.33(8.3)	0.60(15.2)
3/16	-BBLU-FL3	2.03(51.6)	0.54(13.7)	0.12(3.0)	0.50(12.7)	0.50(12.7)	1.00(25.4)	0.56(14.3)	0.39(9.9)	0.61(15.5)
1/4	-BBLU-FL4	2.10(53.3)	0.60(15.2)	0.19(4.8)	0.56(14.3)	0.50(12.7)	1.06(26.9)	0.63(15.9)	0.45(11.5)	0.61(15.5)
5/6	-BBLU-FL5	2.30(58.4)	0.64(16.3)	0.25(6.4)	0.63(15.9)	0.63(15.9)	1.13(28.7)	0.69(17.5)	0.52(13.1)	0.74(18.8)
3/8	-BBLU-FL6	2.36(59.9)	0.66(16.8)	0.28(7.1)	0.69(15.7)	0.63(15.9)	1.20(30.5)	0.75(19.1)	0.58(14.7)	0.74(18.8)
1/2	-BBLU-FL8	2.67(67.8)	0.90(22.9)	0.41(10.4)	0.87(22.2)	0.81(20.6)	1.42(36.1)	0.94(23.8)	0.76(19.4)	0.74(18.8)
5/8	-BBLU-FL10	2.82(71.6)	0.96(24.4)	0.50(12.7)	1.00(25.4)	0.94(23.8)	1.50(38.1)	1.06(27.0)	0.89(22.6)	0.50(12.7)
3/4	-BBLU-FL12	3.08(78.2)	0.96(24.4)	0.62(12.7)	1.13(28.6)	1.06(27.0)	1.57(39.9)	1.19(30.2)	1.02(25.0)	0.66(16.8)

Male Branch Tees

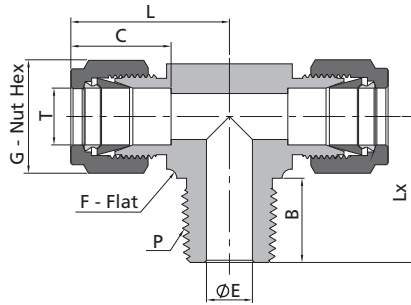

Tube Fittings

Fractional Tube			NPT Thread						
T-Tube O.D. (in.)	P-NPT Size	Basic Ordering Number	Dimensions, in. (mm)						
			L	C	G	F	E	B	Lx
1/8	1/8	-TTM-FL2-NS2	0.93(23.6)	0.50(12.7)	0.44(11.1)	0.44(11.1)	0.09(2.3)	0.38(9.7)	0.70(17.8)
1/8	1/4	-TTM-FL2-NS4	0.97(24.6)	0.50(12.7)	0.44(11.1)	0.50(12.7)	0.09(2.3)	0.56(14.2)	0.92(23.4)
3/16	1/8	-TTM-FL3-NS2	0.96(24.4)	0.54(13.7)	0.50(12.7)	0.44(11.1)	0.12(3.0)	0.38(9.7)	0.70(17.8)
1/4	1/8	-TTM-FL4-NS2	1.06(26.9)	0.60(15.2)	0.56(14.3)	0.50(12.7)	0.19(4.8)	0.38(9.7)	0.74(18.8)
1/4	1/4	-TTM-FL4-NS4	1.06(26.9)	0.60(15.2)	0.56(14.3)	0.50(12.7)	0.19(4.8)	0.56(14.2)	0.92(23.4)
5/16	1/8	-TTM-FL5-NS2	1.17(29.7)	0.64(16.3)	0.63(15.9)	0.63(15.9)	0.19(4.8)	0.38(9.7)	0.82(20.8)
5/16	1/4	-TTM-FL5-NS4	1.17(29.7)	0.64(16.3)	0.63(15.9)	0.63(15.9)	0.25(6.4)	0.56(14.2)	1.01(25.7)
3/8	1/4	-TTM-FL6-NS4	1.20(30.5)	0.66(16.8)	0.69(17.5)	0.63(15.9)	0.28(7.1)	0.56(14.2)	1.00(25.4)
3/8	3/8	-TTM-FL6-NS6	1.31(33.3)	0.66(16.8)	0.69(17.5)	0.81(20.6)	0.28(7.1)	0.56(14.2)	1.11(28.2)
1/2	3/8	-TTM-FL8-NS6	1.42(36.1)	0.90(22.9)	0.87(22.2)	0.81(20.6)	0.38(9.7)	0.56(14.2)	1.11(28.2)
1/2	1/2	-TTM-FL8-NS8	1.42(36.1)	0.90(22.9)	0.87(22.2)	0.81(20.6)	0.41(10.4)	0.75(19.1)	1.30(33.0)
5/8	1/2	-TTM-FL10-NS8	1.53(38.9)	0.96(24.4)	1.00(25.4)	1.00(25.4)	0.47(11.9)	0.75(19.1)	1.41(35.8)
3/4	3/4	-TTM-FL12-NS12	1.57(39.9)	0.96(24.4)	1.13(28.6)	1.06(27.0)	0.62(15.7)	0.75(19.1)	1.45(36.8)
7/8	3/4	-TTM-FL14-NS12	1.76(44.7)	1.02(25.9)	1.25(31.8)	1.37(34.9)	0.62(15.7)	0.75(19.1)	1.50(38.1)
1	3/4	-TTM-FL16-NS12	1.94(49.3)	1.23(31.2)	1.50(38.1)	1.37(34.9)	0.62(15.7)	0.75(19.1)	1.67(42.4)
1	1	-TTM-FL16-NS16	1.94(49.3)	1.23(31.2)	1.50(38.1)	1.37(34.9)	0.88(22.4)	0.94(23.9)	1.84(46.7)

Metric Tube			NPT Thread						
T-Tube O.D. (mm)	P-NPT Size	Basic Ordering Number	Dimensions, mm (in.)						
			L	C	G	F	E	B	Lx
6	1/8	-TTM-ML6-NS2	27.0(1.06)	15.3(0.60)	14.0(0.55)	12.7(0.50)	4.8(0.19)	9.7(0.38)	18.8(0.74)
6	1/4	-TTM-ML6-NS4	27.0(1.06)	15.3(0.60)	14.0(0.55)	12.7(0.50)	4.8(0.19)	14.2(0.56)	23.4(0.92)
8	1/8	-TTM-ML8-NS2	29.9(1.18)	16.2(0.64)	16.0(0.63)	15.9(0.63)	4.8(0.19)	9.7(0.38)	20.8(0.82)
8	1/4	-TTM-ML8-NS4	29.9(1.18)	16.2(0.64)	16.0(0.63)	15.9(0.63)	6.4(0.25)	14.2(0.56)	25.4(1.00)
10	1/4	-TTM-ML10-NS4	33.5(1.32)	17.2(0.68)	19.0(0.75)	20.6(0.81)	7.1(0.28)	14.2(0.56)	28.2(1.11)
10	3/8	-TTM-ML10-NS6	33.5(1.32)	17.2(0.68)	19.0(0.75)	20.6(0.81)	7.9(0.31)	14.2(0.56)	28.2(1.11)
12	1/4	-TTM-ML12-NS4	36.0(1.42)	22.8(0.90)	22.0(0.87)	20.6(0.81)	7.1(0.28)	14.2(0.56)	28.2(1.11)
12	3/8	-TTM-ML12-NS6	36.0(1.42)	22.8(0.90)	22.0(0.87)	20.6(0.81)	9.5(0.37)	14.2(0.56)	28.2(1.11)
12	1/2	-TTM-ML12-NS8	36.0(1.42)	22.8(0.90)	22.0(0.87)	20.6(0.81)	9.5(0.37)	19.1(0.75)	33.0(1.30)
16	1/2	-TTM-ML16-NS8	38.8(1.53)	24.4(0.96)	25.0(0.98)	25.4(1.00)	11.9(0.47)	19.1(0.75)	35.8(1.41)

Male Run Tees

Tube Fittings

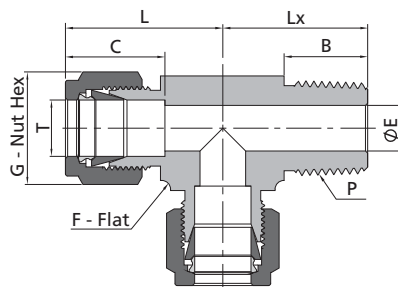

Fractional Tube			NPT Thread						
T-Tube O.D. (in.)	P-NPT Size	Basic Ordering Number	Dimensions, in. (mm)						
			L	C	G	F	E	B	Lx
1/8	1/8	-TMT-FL2-NS2	0.93(23.6)	0.50(12.7)	0.44(11.1)	0.44(11.1)	0.09(2.3)	0.38(9.7)	0.70(17.8)
1/8	1/4	-TMT-FL2-NS4	0.97(24.6)	0.50(12.7)	0.44(11.1)	0.50(12.7)	0.09(2.3)	0.56(14.2)	0.92(23.4)
3/16	1/8	-TMT-FL3-NS2	0.96(24.4)	0.54(13.7)	0.50(12.7)	0.44(11.1)	0.12(3.0)	0.38(9.7)	0.70(17.8)
1/4	1/8	-TMT-FL4-NS2	1.06(26.9)	0.60(15.2)	0.56(14.3)	0.50(12.7)	0.19(4.8)	0.38(9.7)	0.74(18.8)
1/4	1/4	-TMT-FL4-NS4	1.06(26.9)	0.60(15.2)	0.56(14.3)	0.50(12.7)	0.19(4.8)	0.56(14.2)	0.92(23.4)
5/16	1/8	-TMT-FL5-NS2	1.17(29.7)	0.64(16.3)	0.63(15.9)	0.63(15.9)	0.19(4.8)	0.38(9.7)	0.82(20.8)
5/16	1/4	-TMT-FL5-NS4	1.17(29.7)	0.64(16.3)	0.63(15.9)	0.63(15.9)	0.25(6.4)	0.56(14.2)	1.01(25.7)
3/8	1/4	-TMT-FL6-NS4	1.20(30.5)	0.66(16.8)	0.69(17.5)	0.63(15.9)	0.28(7.1)	0.56(14.2)	1.00(25.4)
3/8	3/8	-TMT-FL6-NS6	1.31(33.3)	0.66(16.8)	0.69(17.5)	0.81(20.6)	0.28(7.1)	0.56(14.2)	1.11(28.2)
1/2	3/8	-TMT-FL8-NS6	1.42(36.1)	0.90(22.9)	0.87(22.2)	0.81(20.6)	0.38(9.7)	0.56(14.2)	1.11(28.2)
1/2	1/2	-TMT-FL8-NS8	1.42(36.1)	0.90(22.9)	0.87(22.2)	0.81(20.6)	0.41(10.4)	0.75(19.1)	1.3(33.0)
5/8	1/2	-TMT-FL10-NS8	1.50(38.1)	0.96(24.4)	1.00(25.4)	0.94(23.8)	0.47(11.9)	0.75(19.1)	1.41(35.8)
3/4	3/4	-TMT-FL12-NS12	1.57(39.9)	0.96(24.4)	1.13(28.6)	1.06(27.0)	0.62(15.7)	0.75(19.1)	1.45(36.8)
7/8	3/4	-TMT-FL14-NS12	1.76(44.7)	1.02(25.9)	1.25(31.8)	1.37(34.9)	0.62(15.7)	0.75(19.1)	1.50(38.1)
1	3/4	-TMT-FL16-NS12	1.94(49.3)	1.23(31.2)	1.50(38.1)	1.37(34.9)	0.62(15.7)	0.75(19.1)	1.67(42.4)
1	1	-TMT-FL16-NS16	1.94(49.3)	1.23(31.2)	1.50(38.1)	1.37(34.9)	0.88(22.4)	0.94(23.9)	1.84(46.7)

Metric Tube			NPT Thread						
T-Tube O.D. (mm)	P-NPT Size	Basic Ordering Number	Dimensions, mm (in.)						
			L	C	G	F	E	B	Lx
6	1/8	-TMT-ML6-NS2	27.0(1.06)	15.3(0.60)	14.0(0.55)	12.7(0.50)	4.8(0.19)	9.7(0.38)	18.0(0.71)
6	1/4	-TMT-ML6-NS4	27.0(1.06)	15.3(0.60)	14.0(0.55)	12.7(0.50)	4.8(0.19)	14.2(0.56)	23.4(0.92)
8	1/8	-TMT-ML8-NS2	29.9(1.18)	16.2(0.64)	16.0(0.63)	15.9(0.63)	4.8(0.19)	9.7(0.38)	20.8(0.82)
8	1/4	-TMT-ML8-NS4	29.9(1.18)	16.2(0.64)	16.0(0.63)	15.9(0.63)	6.4(0.25)	14.2(0.56)	25.4(1.00)
10	1/4	-TMT-ML10-NS4	33.5(1.32)	17.2(0.68)	19.0(0.75)	20.6(0.81)	7.1(0.28)	14.2(0.56)	28.2(1.11)
10	1/2	-TMT-ML10-NS8	33.5(1.32)	17.2(0.68)	19.0(0.75)	20.6(0.81)	7.9(0.31)	19.1(0.75)	33.0(1.3)
12	1/4	-TMT-ML12-NS4	36.0(1.42)	22.8(0.90)	22.0(0.87)	20.6(0.81)	7.1(0.28)	14.2(0.56)	28.2(1.11)
12	3/8	-TMT-ML12-NS6	36.0(1.42)	22.8(0.90)	22.0(0.87)	20.6(0.81)	9.5(0.37)	14.2(0.56)	28.2(1.11)
12	1/2	-TMT-ML12-NS8	36.0(1.42)	22.8(0.90)	22.0(0.87)	20.6(0.81)	9.5(0.37)	19.1(0.75)	33.0(1.30)
16	1/2	-TMT-ML16-NS8	38.0(1.50)	24.4(0.96)	25.0(0.98)	23.8(0.94)	11.9(0.47)	19.1(0.75)	35.0(1.38)

Adjustable Male Branch Tees

SAE/MS Straight Thread

Adapt to straight thread boss of SAE J1926-1, ISO 11926-1 and MS 16142.

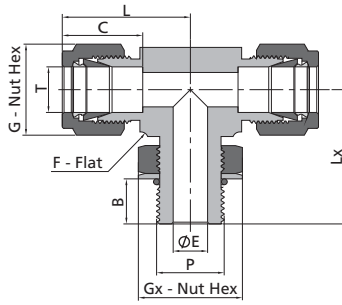

Fractional Tube			SAE/MS Straight Thread								
T-Tube O.D. (in.)	P-SAE/MS Thread Size	Basic Ordering Number	Dimensions, in. (mm)								
			L	B	C	E	G	F	Lx	Gx	
1/4	7/16-20	-TTP-FL4-ST7	1.12(28.5)	0.39(9.9)	0.60(15.2)	0.19(4.8)	0.56(14.3)	0.50(12.7)	1.06(27.0)	0.56(14.3)	
3/8	9/16-18	-TTP-FL6-ST9	1.26(32.0)	0.44(11.2)	0.66(16.8)	0.28(7.1)	0.69(17.5)	0.63(15.9)	1.27(32.3)	0.69(17.5)	
1/2	3/4-16	-TTP-FL8-ST12	1.48(37.6)	0.50(12.7)	0.90(22.9)	0.41(10.4)	0.87(22.2)	0.81(20.6)	1.49(37.8)	0.87(22.2)	
3/4	1 1/16-12	-TTP-FL12-ST17	1.63(41.4)	0.66(16.8)	0.96(24.4)	0.62(15.7)	1.13(28.6)	1.06(27.0)	1.92(48.8)	1.25(31.8)	
1	1 5/16-12	-TTP-FL16-ST21	1.99(50.5)	0.66(16.8)	1.23(31.2)	0.88(22.4)	1.50(38.1)	1.37(34.9)	2.11(53.6)	1.50(38.1)	
1 1/4	1 5/8-12	-TTP-FL20-ST26	2.67(67.8)	0.66(16.8)	1.62(41.1)	1.09(27.7)	1.87(47.6)	1.69(42.9)	2.29(58.2)	1.87(47.6)	
1 1/2	1 7/8-12	-TTP-FL24-ST30	3.07(78.0)	0.66(16.8)	1.97(50.0)	1.34(34.0)	2.25(57.2)	2.00(50.8)	2.38(60.5)	2.13(54.0)	

Adjustable Male Branch Tees

ISO Parallel Thread

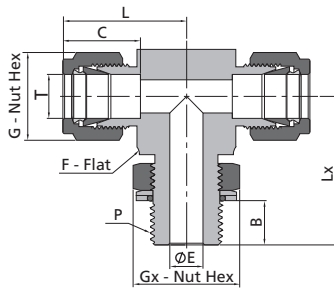

Fractional Tube			ISO Parallel Thread (PP)								
T-Tube O.D. (in.)	P-ISO Parallel Thread Size	Basic Ordering Number	Dimensions, in. (mm)								
			L	B	C	E	G	F	Lx	Gx	
1/4	1/8	-TTP-FL4-PP2	1.06(26.9)	0.26(6.6)	0.60(15.2)	0.16(4.1)	0.56(14.3)	0.50(12.7)	1.04(26.4)	0.56(14.3)	
1/4	1/4	-TTP-FL4-PP4	1.14(29.0)	0.35(9.0)	0.60(15.2)	0.19(4.8)	0.56(14.3)	0.63(15.9)	1.27(32.3)	0.75(19.1)	
3/8	1/4	-TTP-FL6-PP4	1.20(30.5)	0.35(9.0)	0.66(16.8)	0.23(5.8)	0.69(17.5)	0.63(15.9)	1.27(32.3)	0.75(19.1)	
1/2	3/8	-TTP-FL8-PP6	1.42(36.1)	0.37(9.4)	0.90(22.9)	0.31(7.9)	0.87(22.2)	0.81(20.6)	1.46(37.1)	0.87(22.2)	
1/2	1/2	-TTP-FL8-PP8	1.50(38.1)	0.51(13.0)	0.90(22.9)	0.41(10.4)	0.87(22.2)	0.94(23.8)	1.71(43.4)	1.06(27.0)	
5/8	1/2	-TTP-FL10-PP8	1.50(38.1)	0.51(13.0)	0.96(24.4)	0.47(11.9)	1.00(25.4)	0.94(23.8)	1.71(43.4)	1.06(27.0)	
3/4	1/2	-TTP-FL12-PP8	1.57(39.9)	0.51(13.0)	0.96(24.4)	0.47(11.9)	1.13(28.6)	1.06(27.0)	1.78(45.2)	1.06(27.0)	
3/4	3/4	-TTP-FL12-PP12	1.57(39.9)	0.51(13.0)	0.96(24.4)	0.62(15.7)	1.13(28.6)	1.06(27.0)	1.92(48.8)	1.37(34.9)	
1	1	-TTP-FL16-PP16	1.93(49.0)	0.52(13.2)	1.23(31.2)	0.78(19.8)	1.50(38.1)	1.37(34.9)	2.11(53.6)	1.63(41.3)	

Metric Tube			ISO Parallel Thread (PP)								
T-Tube O.D. (mm)	P-ISO Parallel Thread Size	Basic Ordering Number	Dimensions, mm (in.)								
			L	B	C	E	G	F	Lx	Gx	
6	1/8	-TTP-ML6-PP2	27.0(1.06)	6.6(0.26)	15.3(0.60)	4.0(0.16)	14.0(0.55)	12.7(0.50)	26.4(1.04)	14.3(0.56)	
6	1/4	-TTP-ML6-PP4	29.0(1.14)	9.0(0.35)	15.3(0.60)	4.8(0.19)	14.0(0.55)	15.9(0.63)	32.2(1.27)	19.1(0.75)	
8	1/8	-TTP-ML8-PP2	28.8(1.13)	6.6(0.26)	16.2(0.64)	4.0(0.16)	16.0(0.63)	14.3(0.56)	27.5(1.08)	14.3(0.56)	
8	1/4	-TTP-ML8-PP4	29.9(1.18)	9.0(0.35)	16.2(0.64)	5.9(0.23)	16.0(0.63)	15.9(0.63)	32.2(1.27)	19.1(0.75)	
10	1/4	-TTP-ML10-PP4	33.5(1.32)	9.0(0.35)	17.2(0.68)	5.9(0.23)	19.0(0.75)	20.6(0.81)	35.1(1.38)	19.1(0.75)	
12	3/8	-TTP-ML12-PP6	36.0(1.42)	9.4(0.37)	22.8(0.90)	7.9(0.31)	22.0(0.87)	20.6(0.81)	37.1(1.46)	22.2(0.87)	
12	1/2	-TTP-ML12-PP8	38.0(1.50)	13.0(0.51)	22.8(0.90)	9.5(0.37)	22.0(0.87)	23.8(0.94)	43.5(1.71)	27.0(1.06)	

Adjustable Male Run Tees

SAE/MS Straight Thread

Adapt to straight thread boss of SAE J1926-1, ISO 11926-1 and MS 16142.

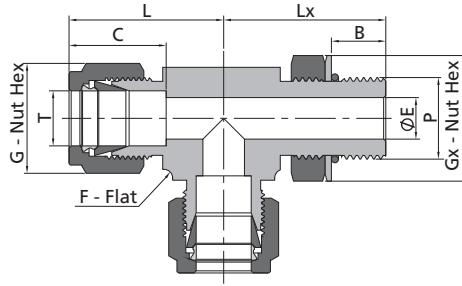

Fractional Tube			SAE/MS Straight Thread							
T-Tube O.D. (in.)	P-SAE/MS Thread Size	Basic Ordering Number	Dimensions, in. (mm)							
			L	B	C	E	G	F	Lx	Gx
1/4	7/16-20	-TPT-FL4-ST7	1.12(28.5)	0.39(9.9)	0.60(15.2)	0.19(4.8)	0.56(14.3)	0.50(12.7)	1.06(27.0)	0.56(14.3)
3/8	9/16-18	-TPT-FL6-ST9	1.26(32.0)	0.44(11.2)	0.66(16.8)	0.28(7.1)	0.69(17.5)	0.63(15.9)	1.27(32.3)	0.69(17.5)
1/2	3/4-16	-TPT-FL8-ST12	1.48(37.6)	0.50(12.7)	0.90(22.9)	0.41(10.4)	0.87(22.2)	0.81(20.6)	1.49(37.8)	0.87(22.2)
3/4	1 1/16-12	-TPT-FL12-ST17	1.63(41.4)	0.66(16.8)	0.96(24.4)	0.62(15.7)	1.25(31.75)	1.06(27.0)	1.92(48.8)	1.25(31.8)
1	1 5/16-12	-TPT-FL16-ST21	1.99(50.5)	0.66(16.8)	1.23(31.2)	0.88(22.4)	1.50(38.1)	1.37(34.9)	2.11(53.6)	1.50(38.1)
1 1/4	1 5/8-12	-TPT-FL20-ST26	2.67(67.8)	0.66(16.8)	1.62(41.1)	1.09(27.7)	1.87(47.6)	1.69(42.9)	2.29(58.2)	1.87(47.6)
1 1/2	1 7/8-12	-TPT-FL24-ST30	3.07(78.0)	0.66(16.8)	1.97(50.0)	1.34(34.0)	2.25(57.2)	2.00(50.8)	2.38(60.5)	2.13(54.0)

Adjustable Male Run Tees

ISO Parallel Thread

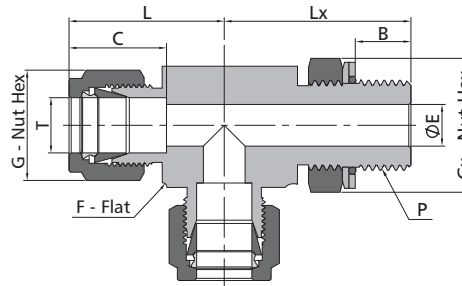

Fractional Tube			ISO Parallel Thread (PP)							
T-Tube O.D. (in.)	P-ISO Parallel Thread Size	Basic Ordering Number	Dimensions, in. (mm)							
			L	B	C	E	G	F	Lx	Gx
1/4	1/8	-TPT-FL4-PP2	1.06(26.9)	0.26(6.6)	0.60(15.2)	0.16(4.1)	0.56(14.3)	0.50(12.7)	1.04(26.4)	0.56(14.3)
1/4	1/4	-TPT-FL4-PP4	1.14(29.0)	0.35(9.0)	0.60(15.2)	0.19(4.8)	0.56(14.3)	0.63(15.9)	1.27(32.3)	0.75(19.1)
3/8	1/4	-TPT-FL6-PP4	1.20(30.5)	0.35(9.0)	0.66(16.8)	0.23(5.8)	0.69(17.5)	0.63(15.9)	1.27(32.3)	0.75(19.1)
1/2	3/8	-TPT-FL8-PP6	1.42(36.1)	0.37(9.4)	0.90(22.9)	0.31(7.9)	0.87(22.2)	0.81(20.6)	1.46(37.1)	0.87(22.2)
1/2	1/2	-TPT-FL8-PP8	1.50(38.1)	0.51(13.0)	0.90(22.9)	0.41(10.4)	0.87(22.2)	0.94(23.8)	1.71(43.4)	1.06(27.0)
5/8	1/2	-TPT-FL10-PP8	1.50(38.1)	0.51(13.0)	0.96(24.4)	0.47(11.9)	1.00(25.4)	0.94(23.8)	1.71(43.4)	1.06(27.0)
3/4	1/2	-TPT-FL12-PP8	1.57(39.9)	0.51(13.0)	0.96(24.4)	0.47(11.9)	1.13(28.6)	1.06(27.0)	1.78(45.2)	1.06(27.0)
3/4	3/4	-TPT-FL12-PP12	1.57(39.9)	0.51(13.0)	0.96(24.4)	0.62(15.7)	1.13(28.6)	1.06(27.0)	1.92(48.8)	1.37(34.9)
1	1	-TPT-FL16-PP16	1.93(49.0)	0.52(13.2)	1.23(31.2)	0.78(19.8)	1.50(38.1)	1.37(34.9)	2.11(53.6)	1.63(41.3)

Metric Tube			ISO Parallel Thread (PP)							
T-Tube O.D. (mm)	P-ISO Parallel Thread Size	Basic Ordering Number	Dimensions, mm (in.)							
			L	B	C	E	G	F	Lx	Gx
6	1/8	-TPT-ML6-PP2	27.0(1.06)	6.6(0.26)	15.3(0.60)	4.0(0.16)	14.0(0.55)	12.7(0.50)	26.4(1.04)	14.3(0.56)
6	1/4	-TPT-ML6-PP4	29.0(1.14)	9.0(0.35)	15.3(0.60)	4.8(0.19)	14.0(0.55)	15.9(0.63)	32.2(1.27)	19.1(0.75)
8	1/8	-TPT-ML8-PP2	28.8(1.13)	6.6(0.26)	16.2(0.64)	4.0(0.16)	16.0(0.63)	14.3(0.56)	27.5(1.08)	14.3(0.56)
8	1/4	-TPT-ML8-PP4	29.9(1.18)	9.0(0.35)	16.2(0.64)	5.9(0.23)	16.0(0.63)	15.9(0.63)	32.2(1.27)	19.1(0.75)
10	1/4	-TPT-ML10-PP4	33.5(1.32)	9.0(0.35)	17.2(0.68)	5.9(0.23)	19.0(0.75)	20.6(0.81)	35.1(1.38)	19.1(0.75)
12	3/8	-TPT-ML12-PP6	36.0(1.42)	9.4(0.37)	22.8(0.90)	7.9(0.31)	22.0(0.87)	20.6(0.81)	37.1(1.46)	22.2(0.87)
12	1/2	-TPT-ML12-PP8	38.0(1.50)	13.0(0.51)	22.8(0.90)	9.5(0.37)	22.0(0.87)	23.8(0.94)	43.5(1.71)	27.0(1.06)

Female Branch Tees

Tube Fittings

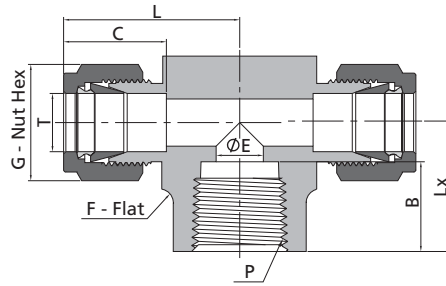

Fractional Tube			NPT Thread						
T-Tube O.D. (in.)	P-NPT Size	Basic Ordering Number	Dimensions, in. (mm)						
			L	C	G	F	E	B	Lx
1/8	1/8	-TTF-FL2-NS2	0.97(24.6)	0.50(12.7)	0.44(11.1)	0.50(12.7)	0.09(2.3)	0.41(10.4)	0.75(19.1)
3/16	1/8	-TTF-FL3-NS2	1.01(25.7)	0.54(13.7)	0.50(12.7)	0.50(12.7)	0.12(3.0)	0.41(10.4)	0.75(19.1)
1/4	1/8	-TTF-FL4-NS2	1.06(26.9)	0.60(15.2)	0.56(14.3)	0.50(12.7)	0.19(4.8)	0.41(10.4)	0.75(19.1)
1/4	1/4	-TTF-FL4-NS4	1.17(29.7)	0.60(15.2)	0.56(14.3)	0.69(17.5)	0.19(4.8)	0.59(15.0)	0.88(22.4)
5/16	1/8	-TTF-FL5-NS2	1.17(29.7)	0.64(16.2)	0.63(15.9)	0.63(15.9)	0.25(6.4)	0.41(10.4)	0.75(19.1)
3/8	1/4	-TTF-FL6-NS4	1.23(31.2)	0.66(16.8)	0.69(17.5)	0.69(17.5)	0.28(7.1)	0.59(15.0)	0.88(22.4)
3/8	3/8	-TTF-FL6-NS6	1.31(33.3)	0.66(16.8)	0.69(17.5)	0.81(20.6)	0.28(7.1)	0.59(15.0)	0.88(22.4)
3/8	1/2	-TTF-FL6-NS8	1.42(36.1)	0.66(16.8)	0.69(17.5)	1.00(25.4)	0.28(7.1)	0.78(19.8)	1.12(28.4)
1/2	1/4	-TTF-FL8-NS4	1.42(36.1)	0.90(22.9)	0.87(22.2)	0.81(20.6)	0.41(10.4)	0.59(15.0)	0.88(22.4)
1/2	3/8	-TTF-FL8-NS6	1.42(36.1)	0.90(22.9)	0.87(22.2)	0.81(20.6)	0.41(10.4)	0.59(15.0)	0.88(22.4)
1/2	1/2	-TTF-FL8-NS8	1.53(38.9)	0.90(22.9)	0.87(22.2)	1.00(25.4)	0.41(10.4)	0.78(19.8)	1.12(28.4)
5/8	1/2	-TTF-FL10-NS8	1.53(38.9)	0.96(24.4)	1.00(25.4)	1.00(25.4)	0.50(12.7)	0.78(19.8)	1.12(28.4)
3/4	3/4	-TTF-FL12-NS12	1.76(44.7)	0.96(24.4)	1.13(28.6)	1.37(34.9)	0.62(15.7)	0.81(20.6)	1.25(31.8)
7/8	3/4	-TTF-FL14-NS12	1.76(44.7)	1.02(25.9)	1.25(31.8)	1.37(34.9)	0.72(18.3)	0.81(20.6)	1.25(31.8)
1	3/4	-TTF-FL16-NS12	1.93(49.0)	1.23(31.2)	1.50(38.1)	1.37(34.9)	0.88(22.4)	0.81(20.6)	1.25(31.8)
1	1	-TTF-FL16-NS16	2.11(53.6)	1.23(31.2)	1.50(38.1)	1.69(42.9)	0.88(22.4)	1.00(25.4)	1.50(38.1)

Metric Tube			NPT Thread						
T-Tube O.D. (mm)	P-NPT Size	Basic Ordering Number	Dimensions, mm (in.)						
			L	C	G	F	E	B	Lx
6	1/8	-TTF-ML6-NS2	27.0(1.06)	15.3(0.60)	14.0(0.55)	12.7(0.50)	4.8(0.19)	10.4(0.41)	19.0(0.75)
6	1/4	-TTF-ML6-NS4	29.8(1.17)	15.3(0.60)	14.0(0.55)	17.5(0.69)	4.8(0.19)	15.0(0.59)	22.4(0.88)
8	1/8	-TTF-ML8-NS2	29.9(1.18)	16.2(0.64)	16.0(0.63)	15.9(0.63)	6.4(0.25)	10.4(0.41)	19.0(0.75)
8	1/4	-TTF-ML8-NS4	30.6(1.2)	16.2(0.64)	16.0(0.63)	17.5(0.69)	6.4(0.25)	15.0(0.59)	22.4(0.88)
10	1/4	-TTF-ML10-NS4	33.5(1.32)	17.2(0.68)	19.0(0.75)	20.6(0.81)	7.9(0.31)	15.0(0.59)	22.4(0.88)
12	1/8	-TTF-ML12-NS2	36.0(1.42)	22.8(0.90)	22.0(0.87)	20.6(0.81)	6.4(0.25)	10.4(0.41)	22.3(0.88)
12	1/4	-TTF-ML12-NS4	36.0(1.42)	22.8(0.90)	22.0(0.87)	20.6(0.81)	9.5(0.37)	15.0(0.59)	22.4(0.88)
12	3/8	-TTF-ML12-NS6	36.0(1.42)	22.8(0.90)	22.0(0.87)	20.6(0.81)	9.5(0.37)	15.0(0.59)	22.4(0.88)
12	1/2	-TTF-ML12-NS8	38.8(1.53)	22.8(0.90)	22.0(0.87)	25.4(1.00)	9.5(0.37)	19.8(0.78)	28.5(1.12)
16	1/2	-TTF-ML16-NS8	38.8(1.53)	24.4(0.96)	25.0(0.98)	25.4(1.00)	12.7(0.50)	19.8(0.78)	28.4(1.12)

Female Run Tees

Tube Fittings

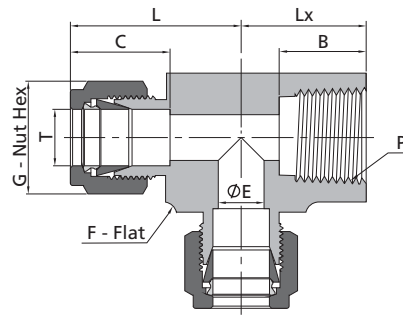

Fractional Tube			NPT Thread						
T-Tube O.D. (in.)	P-NPT Size	Basic Ordering Number	Dimensions, in. (mm)						
			L	C	G	F	E	B	Lx
1/8	1/8	-TFT-FL2-NS2	0.97(24.6)	0.50(12.7)	0.44(11.1)	0.50(12.7)	0.09(2.3)	0.41(10.4)	0.75(19.1)
3/16	1/8	-TFT-FL3-NS2	1.01(25.7)	0.54(13.7)	0.50(12.7)	0.50(12.7)	0.12(3.0)	0.41(10.4)	0.75(19.1)
1/4	1/8	-TFT-FL4-NS2	1.06(26.9)	0.60(15.2)	0.56(14.3)	0.50(12.7)	0.19(4.8)	0.41(10.4)	0.75(19.1)
1/4	1/4	-TFT-FL4-NS4	1.17(29.7)	0.60(15.2)	0.56(14.3)	0.69(17.5)	0.19(4.8)	0.59(15.0)	0.88(22.4)
5/16	1/8	-TFT-FL5-NS2	1.17(29.7)	0.64(16.2)	0.63(15.9)	0.63(15.9)	0.25(6.4)	0.41(10.4)	0.75(19.1)
3/8	1/4	-TFT-FL6-NS4	1.23(31.2)	0.66(16.8)	0.69(17.5)	0.69(17.5)	0.28(7.1)	0.59(15.0)	0.88(22.4)
1/2	1/4	-TFT-FL8-NS4	1.42(36.1)	0.90(22.9)	0.87(22.2)	0.81(20.6)	0.41(10.4)	0.59(15.0)	0.88(22.4)
1/2	3/8	-TFT-FL8-NS6	1.42(36.1)	0.90(22.9)	0.87(22.2)	0.81(20.6)	0.41(10.4)	0.59(15.0)	0.88(22.4)
1/2	1/2	-TFT-FL8-NS8	1.57(39.9)	0.90(22.9)	0.87(22.2)	1.06(27.0)	0.41(10.4)	0.78(19.8)	1.12(28.4)
5/8	1/2	-TFT-FL10-NS8	1.57(39.9)	0.96(24.4)	1.00(25.4)	1.06(27.0)	0.50(12.7)	0.78(19.8)	1.12(28.4)
3/4	3/4	-TFT-FL12-NS12	1.76(44.7)	0.96(24.4)	1.13(28.6)	1.37(34.9)	0.62(15.7)	0.81(20.6)	1.25(31.8)
7/8	1/2	-TFT-FL14-NS8	1.76(44.7)	1.02(25.9)	1.25(31.8)	1.37(34.9)	0.62(15.7)	0.78(19.8)	1.12(28.4)
7/8	3/4	-TFT-FL14-NS12	1.76(44.7)	1.02(25.9)	1.25(31.8)	1.37(34.9)	0.72(18.3)	0.81(20.6)	1.25(31.8)
1	3/4	-TFT-FL16-NS12	1.93(49.0)	1.23(31.2)	1.50(38.1)	1.37(34.9)	0.88(22.4)	0.81(20.6)	1.25(31.8)
1	1	-TFT-FL16-NS16	2.11(53.6)	1.23(31.2)	1.50(38.1)	1.69(42.9)	0.88(22.4)	1.00(25.4)	1.50(38.1)

Metric Tube			NPT Thread						
T-Tube O.D. (mm)	P-NPT Size	Basic Ordering Number	Dimensions, mm (in.)						
			L	C	G	F	E	B	Lx
6	1/8	-TFT-ML6-NS2	27.0(1.06)	15.3(0.60)	14.0(0.55)	12.7(0.50)	4.8(0.19)	10.4(0.41)	19.0(0.75)
6	1/4	-TFT-ML6-NS4	29.8(1.17)	15.3(0.60)	14.0(0.55)	17.5(0.69)	4.8(0.19)	15.0(0.59)	22.4(0.88)
8	1/8	-TFT-ML8-NS2	29.9(1.18)	16.2(0.64)	16.0(0.63)	15.9(0.63)	6.4(0.25)	10.4(0.41)	19.0(0.75)
8	1/4	-TFT-ML8-NS4	30.6(1.20)	16.2(0.64)	16.0(0.63)	17.5(0.69)	6.4(0.25)	15.0(0.59)	22.4(0.88)
10	1/4	-TFT-ML10-NS4	33.5(1.32)	17.2(0.68)	19.0(0.75)	20.6(0.81)	7.9(0.31)	15.0(0.59)	22.4(0.88)
12	1/4	-TFT-ML12-NS4	36.0(1.42)	22.8(0.90)	22.0(0.87)	20.6(0.81)	9.5(0.37)	15.0(0.59)	22.4(0.88)
12	3/8	-TFT-ML12-NS6	36.0(1.42)	22.8(0.90)	22.0(0.87)	20.6(0.81)	9.5(0.37)	15.0(0.59)	23.1(0.91)
12	1/2	-TFT-ML12-NS8	38.8(1.53)	22.8(0.90)	22.0(0.87)	25.4(1.00)	9.5(0.37)	19.8(0.78)	28.5(1.12)
16	1/2	-TFT-ML16-NS8	39.8(1.57)	24.4(0.96)	25.0(0.98)	27.0(1.06)	12.7(0.50)	19.8(0.78)	28.4(1.12)

Union Tees

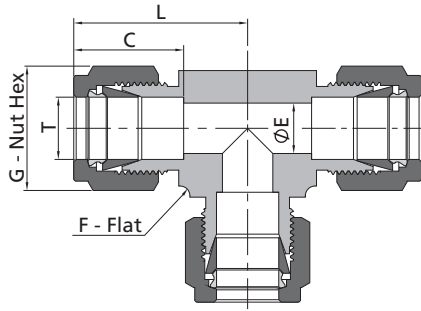

Fractional Tube						
T-Tube O.D. (in.)	Basic Ordering Number	Dimensions, in. (mm)				
		L	C	G	F	E
1/16	-TTT-FL1	0.70(17.8)	0.34(8.6)	0.31(7.9)	0.37(9.5)	0.05(1.3)
1/8	-TTT-FL2	0.87(22.2)	0.50(12.7)	0.44(11.1)	0.37(9.5)	0.09(2.3)
3/16	-TTT-FL3	0.96(24.4)	0.54(13.7)	0.50(12.7)	0.44(11.1)	0.12(3.0)
1/4	-TTT-FL4	1.06(26.9)	0.60(15.2)	0.56(14.3)	0.50(12.7)	0.19(4.8)
5/16	-TTT-FL5	1.17(29.7)	0.64(16.2)	0.63(15.9)	0.63(15.9)	0.25(6.4)
3/8	-TTT-FL6	1.20(30.5)	0.66(16.8)	0.69(17.5)	0.63(15.9)	0.28(7.1)
1/2	-TTT-FL8	1.42(36.1)	0.90(22.9)	0.87(22.2)	0.81(20.6)	0.41(10.4)
5/8	-TTT-FL10	1.53(38.9)	0.96(24.4)	1.00(25.4)	1.00(25.4)	0.50(12.7)
3/4	-TTT-FL12	1.57(39.9)	0.96(24.4)	1.13(28.6)	1.06(27.0)	0.62(15.7)
7/8	-TTT-FL14	1.76(44.7)	1.02(25.9)	1.25(31.8)	1.37(34.9)	0.72(18.3)
1	-TTT-FL16	1.93(49.0)	1.23(31.2)	1.50(38.1)	1.37(34.9)	0.88(22.4)
1 1/8	-TTT-FL18	2.17(55.1)	1.44(36.7)	1.75(44.5)	1.69(42.9)	0.97(24.6)
1 1/4	-TTT-FL20	2.62(66.5)	1.62(41.1)	1.87(47.6)	1.69(42.9)	1.09(27.7)
1 1/2	-TTT-FL24	3.07(78.0)	1.97(50.0)	2.25(57.2)	2.00(50.8)	1.34(34.0)

Metric Tube						
T-Tube O.D. (mm)	Basic Ordering Number	Dimensions, mm (in.)				
		L	C	G	F	E
2	-TTT-ML2	22.3(0.88)	12.9(0.51)	12.0(0.47)	9.5(0.37)	1.7(0.07)
3	-TTT-ML3	22.3(0.88)	12.9(0.51)	12.0(0.47)	9.5(0.37)	2.4(0.09)
4	-TTT-ML4	25.4(1.00)	13.7(0.54)	12.0(0.47)	12.7(0.50)	2.4(0.09)
6	-TTT-ML6	27.0(1.06)	15.3(0.60)	14.0(0.55)	12.7(0.50)	4.8(0.19)
8	-TTT-ML8	29.9(1.18)	16.2(0.64)	16.0(0.63)	15.9(0.63)	6.4(0.25)
10	-TTT-ML10	31.5(1.24)	17.2(0.68)	19.0(0.75)	17.5(0.69)	7.9(0.31)
12	-TTT-ML12	36.0(1.42)	22.8(0.90)	22.0(0.87)	20.6(0.81)	9.5(0.37)
14	-TTT-ML14	38.8(1.53)	24.4(0.96)	25.0(0.98)	25.4(1.00)	11.1(0.44)
15	-TTT-ML15	38.8(1.53)	24.4(0.96)	25.0(0.98)	25.4(1.00)	11.9(0.47)
16	-TTT-ML16	38.8(1.53)	24.4(0.96)	25.0(0.98)	25.4(1.00)	12.7(0.50)
18	-TTT-ML18	39.8(1.57)	24.4(0.96)	30.0(1.18)	27.0(1.06)	15.1(0.59)
20	-TTT-ML20	44.6(1.76)	26.0(1.02)	32.0(1.26)	34.9(1.37)	15.9(0.63)
22	-TTT-ML22	44.6(1.76)	26.0(1.02)	32.0(1.26)	34.9(1.37)	18.3(0.72)
25	-TTT-ML25	49.1(1.93)	31.3(1.23)	38.0(1.50)	34.9(1.37)	21.8(0.86)
28	-TTT-ML28	64.0(2.52)	36.6(1.44)	46.0(1.81)	42.9(1.69)	21.8(0.86)
30	-TTT-ML30	69.9(2.75)	39.6(1.56)	50.0(1.97)	42.9(1.69)	26.2(1.03)
32	-TTT-ML32	72.3(2.85)	42.0(1.65)	50.0(1.97)	42.9(1.69)	28.6(1.13)
38	-TTT-ML38	84.0(3.31)	49.4(1.94)	60.0(2.36)	50.8(2.00)	33.7(1.33)

Reducing Union Tees

Tube Fittings

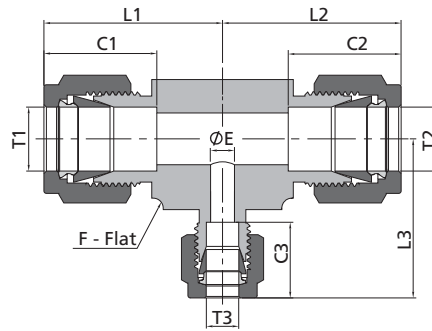

Fractional Tube				Dimensions, in. (mm)								
T1-Tube O.D. (in.)	T2-Tube O.D. (in.)	T3-Tube O.D. (in.)	Basic Ordering Number	L1	L2	L3	C1	C2	C3	F	E	
1/4	1/4	1/8	-TTT-FL4-FL4-FL2	1.05(26.7)	1.05(26.7)	0.96(24.4)	0.60(15.2)	0.60(15.2)	0.50(12.7)	0.50(12.7)	0.09(2.3)	
3/8	1/4	1/4	-TTT-FL6-FL4-FL4	1.20(30.5)	1.14(29.0)	1.14(29.0)	0.66(16.8)	0.60(15.2)	0.60(15.2)	0.63(15.9)	0.19(4.8)	
3/8	1/4	3/8	-TTT-FL6-FL4-FL6	1.20(30.5)	1.14(29.0)	1.20(30.5)	0.66(16.8)	0.60(15.2)	0.66(16.8)	0.63(15.9)	0.19(4.8)	
3/8	3/8	1/4	-TTT-FL6-FL6-FL4	1.20(30.5)	1.20(30.5)	1.14(29.0)	0.66(16.8)	0.66(16.8)	0.60(15.2)	0.63(15.9)	0.19(4.8)	
1/2	1/4	1/4	-TTT-FL8-FL4-FL4	1.42(36.1)	1.22(30.9)	1.22(30.9)	0.90(22.9)	0.60(15.2)	0.60(15.2)	0.81(20.6)	0.19(4.8)	
1/2	1/4	1/2	-TTT-FL8-FL4-FL8	1.42(36.1)	1.25(31.8)	1.42(36.1)	0.90(22.9)	0.60(15.2)	0.90(22.9)	0.81(20.6)	0.19(4.8)	
1/2	3/8	3/8	-TTT-FL8-FL6-FL6	1.42(36.1)	1.31(33.3)	1.31(33.3)	0.90(22.9)	0.66(16.8)	0.66(16.8)	0.81(20.6)	0.28(7.1)	
1/2	3/8	1/2	-TTT-FL8-FL6-FL8	1.42(36.1)	1.31(33.3)	1.42(36.1)	0.90(22.9)	0.66(16.8)	0.90(22.9)	0.81(20.6)	0.28(7.1)	
1/2	1/2	1/4	-TTT-FL8-FL8-FL4	1.42(36.1)	1.42(36.1)	1.25(31.8)	0.90(22.9)	0.90(22.9)	0.60(15.2)	0.81(20.6)	0.19(4.8)	
1/2	1/2	3/8	-TTT-FL8-FL8-FL6	1.42(36.1)	1.42(36.1)	1.31(33.3)	0.90(22.9)	0.90(22.9)	0.66(16.8)	0.81(20.6)	0.28(7.1)	
5/8	3/8	3/8	-TTT-FL10-FL6-FL6	1.53(38.9)	1.42(36.1)	1.42(36.1)	0.96(24.4)	0.66(16.8)	0.66(16.8)	1.00(25.4)	0.28(7.1)	
5/8	3/8	1/2	-TTT-FL10-FL6-FL8	1.53(38.9)	1.42(36.1)	1.53(38.9)	0.96(24.4)	0.66(16.8)	0.90(22.9)	1.00(25.4)	0.28(7.1)	
5/8	1/2	3/8	-TTT-FL10-FL8-FL6	1.53(38.9)	1.53(38.9)	1.42(36.1)	0.96(24.4)	0.90(22.9)	0.66(16.8)	1.00(25.4)	0.28(7.1)	
5/8	1/2	1/2	-TTT-FL10-FL8-FL8	1.53(38.9)	1.53(38.9)	1.53(38.9)	0.96(24.4)	0.90(22.9)	0.90(22.9)	1.00(25.4)	0.41(10.4)	
5/8	5/8	3/8	-TTT-FL10-FL10-FL6	1.53(38.9)	1.53(38.9)	1.42(36.1)	0.96(24.4)	0.96(24.4)	0.66(16.8)	1.00(25.4)	0.28(7.1)	
5/8	5/8	1/2	-TTT-FL10-FL10-FL8	1.53(38.9)	1.53(38.9)	1.53(38.9)	0.96(24.4)	0.96(24.4)	0.90(22.9)	1.00(25.4)	0.41(10.4)	
3/4	3/8	3/8	-TTT-FL12-FL6-FL6	1.56(39.6)	1.45(36.9)	1.45(36.9)	0.96(24.4)	0.66(16.8)	0.66(16.8)	1.06(27.0)	0.28(7.1)	
3/4	1/2	3/8	-TTT-FL12-FL8-FL6	1.56(39.6)	1.56(39.6)	1.45(36.9)	0.96(24.4)	0.90(22.9)	0.66(16.8)	1.06(27.0)	0.28(7.1)	
3/4	1/2	1/2	-TTT-FL12-FL8-FL8	1.56(39.6)	1.56(39.6)	1.56(39.6)	0.96(24.4)	0.90(22.9)	0.90(22.9)	1.06(27.0)	0.41(10.4)	
3/4	5/8	3/8	-TTT-FL12-FL10-FL6	1.56(39.6)	1.56(39.6)	1.45(36.9)	0.96(24.4)	0.96(24.4)	0.66(16.8)	1.06(27.0)	0.28(7.1)	
3/4	5/8	1/2	-TTT-FL12-FL10-FL8	1.56(39.6)	1.56(39.6)	1.56(39.6)	0.96(24.4)	0.96(24.4)	0.90(22.9)	1.06(27.0)	0.41(10.4)	
3/4	5/8	5/8	-TTT-FL12-FL10-FL10	1.56(39.6)	1.56(39.6)	1.56(39.6)	0.96(24.4)	0.96(24.4)	0.96(24.4)	1.06(27.0)	0.50(12.7)	
3/4	3/4	1/4	-TTT-FL12-FL12-FL4	1.56(39.6)	1.56(39.6)	1.43(36.3)	0.96(24.4)	0.96(24.4)	0.60(15.2)	1.06(27.0)	0.19(4.8)	
3/4	3/4	3/8	-TTT-FL12-FL12-FL6	1.56(39.6)	1.56(39.6)	1.45(36.9)	0.96(24.4)	0.96(24.4)	0.66(16.8)	1.06(27.0)	0.28(7.1)	
3/4	3/4	1/2	-TTT-FL12-FL12-FL8	1.56(39.6)	1.56(39.6)	1.56(39.6)	0.96(24.4)	0.96(24.4)	0.90(22.9)	1.06(27.0)	0.41(10.4)	
3/4	3/4	5/8	-TTT-FL12-FL12-FL10	1.56(39.6)	1.56(39.6)	1.56(39.6)	0.96(24.4)	0.96(24.4)	0.96(24.4)	1.06(27.0)	0.50(12.7)	
7/8	1/2	3/4	-TTT-FL14-FL8-FL12	1.76(44.7)	1.76(44.7)	1.76(44.7)	1.02(25.9)	0.90(22.9)	0.96(24.4)	1.37(34.9)	0.41(10.4)	
7/8	5/8	3/8	-TTT-FL14-FL10-FL6	1.76(44.7)	1.76(44.7)	1.65(41.9)	1.02(25.9)	0.96(24.4)	0.66(16.8)	1.37(34.9)	0.28(7.1)	
7/8	3/4	3/8	-TTT-FL14-FL12-FL6	1.76(44.7)	1.76(44.7)	1.65(41.9)	1.02(25.9)	0.96(24.4)	0.66(16.8)	1.37(34.9)	0.28(7.1)	
7/8	3/4	1/2	-TTT-FL14-FL12-FL8	1.76(44.7)	1.76(44.7)	1.76(44.7)	1.02(25.9)	0.96(24.4)	0.90(22.9)	1.37(34.9)	0.41(10.4)	
7/8	3/4	3/4	-TTT-FL14-FL12-FL12	1.76(44.7)	1.76(44.7)	1.76(44.7)	1.02(25.9)	0.96(24.4)	0.96(24.4)	1.37(34.9)	0.62(15.7)	
7/8	7/8	1/4	-TTT-FL14-FL14-FL4	1.76(44.7)	1.76(44.7)	1.59(40.4)	1.02(25.9)	1.02(25.9)	0.60(15.2)	1.37(34.9)	0.19(4.8)	
7/8	7/8	3/8	-TTT-FL14-FL14-FL6	1.76(44.7)	1.76(44.7)	1.65(41.9)	1.02(25.9)	1.02(25.9)	0.66(16.8)	1.37(34.9)	0.28(7.1)	
1	3/8	3/8	-TTT-FL16-FL6-FL6	1.94(49.3)	1.65(41.9)	1.65(41.9)	1.23(31.2)	0.66(16.8)	0.66(16.8)	1.37(34.9)	0.28(7.1)	
1	1/2	1/4	-TTT-FL16-FL8-FL4	1.94(49.3)	1.76(44.7)	1.59(40.4)	1.23(31.2)	0.90(22.9)	0.60(15.2)	1.37(34.9)	0.19(4.8)	
1	1/2	3/8	-TTT-FL16-FL8-FL6	1.94(49.3)	1.76(44.7)	1.65(41.9)	1.23(31.2)	0.90(22.9)	0.66(16.8)	1.37(34.9)	0.28(7.1)	
1	1/2	1/2	-TTT-FL16-FL8-FL8	1.94(49.3)	1.76(44.7)	1.76(44.7)	1.23(31.2)	0.90(22.9)	0.90(22.9)	1.37(34.9)	0.41(10.4)	
1	1/2	1	-TTT-FL16-FL8-FL16	1.94(49.3)	1.76(44.7)	1.94(49.3)	1.23(31.2)	0.90(22.9)	1.23(31.2)	1.37(34.9)	0.41(10.4)	
1	5/8	3/8	-TTT-FL16-FL10-FL6	1.94(49.3)	1.76(44.7)	1.65(41.9)	1.23(31.2)	0.96(24.4)	0.66(16.8)	1.37(34.9)	0.28(7.1)	
1	3/4	3/8	-TTT-FL16-FL12-FL6	1.94(49.3)	1.76(44.7)	1.65(41.9)	1.23(31.2)	0.96(24.4)	0.66(16.8)	1.37(34.9)	0.28(7.1)	
1	3/4	1/2	-TTT-FL16-FL12-FL8	1.94(49.3)	1.76(44.7)	1.76(44.7)	1.23(31.2)	0.96(24.4)	0.90(22.9)	1.37(34.9)	0.41(10.4)	
1	3/4	5/8	-TTT-FL16-FL12-FL10	1.94(49.3)	1.76(44.7)	1.76(44.7)	1.23(31.2)	0.96(24.4)	0.96(24.4)	1.37(34.9)	0.50(12.7)	
1	3/4	1	-TTT-FL16-FL12-FL16	1.94(49.3)	1.76(44.7)	1.94(49.3)	1.23(31.2)	0.96(24.4)	1.23(31.2)	1.37(34.9)	0.62(15.7)	
1	7/8	1/4	-TTT-FL16-FL14-FL4	1.94(49.3)	1.76(44.7)	1.59(40.4)	1.23(31.2)	1.02(25.9)	0.60(15.2)	1.37(34.9)	0.19(4.8)	
1	7/8	3/8	-TTT-FL16-FL14-FL6	1.94(49.3)	1.76(44.7)	1.65(41.9)	1.23(31.2)	1.02(25.9)	0.66(16.8)	1.37(34.9)	0.28(7.1)	
1	7/8	1/2	-TTT-FL16-FL14-FL8	1.94(49.3)	1.76(44.7)	1.76(44.7)	1.23(31.2)	1.02(25.9)	0.90(22.9)	1.37(34.9)	0.41(10.4)	
1	7/8	3/4	-TTT-FL16-FL14-FL12	1.94(49.3)	1.76(44.7)	1.76(44.7)	1.23(31.2)	1.02(25.9)	0.96(24.4)	1.37(34.9)	0.62(15.7)	
1	7/8	7/8	-TTT-FL16-FL14-FL14	1.94(49.3)	1.76(44.7)	1.76(44.7)	1.23(31.2)	1.02(25.9)	1.02(25.9)	1.37(34.9)	0.72(18.3)	
1	1	1/4	-TTT-FL16-FL16-FL4	1.94(49.3)	1.94(49.3)	1.59(40.4)	1.23(31.2)	1.23(31.2)	0.60(15.2)	1.37(34.9)	0.19(4.8)	
1	1	3/8	-TTT-FL16-FL16-FL6	1.94(49.3)	1.94(49.3)	1.65(41.9)	1.23(31.2)	1.23(31.2)	0.66(16.8)	1.37(34.9)	0.28(7.1)	
1	1	1/2	-TTT-FL16-FL16-FL8	1.94(49.3)	1.94(49.3)	1.76(44.7)	1.23(31.2)	1.23(31.2)	0.90(22.9)	1.37(34.9)	0.41(10.4)	
1	1	5/8	-TTT-FL16-FL16-FL10	1.94(49.3)	1.94(49.3)	1.76(44.7)	1.23(31.2)	1.23(31.2)	0.96(24.4)	1.37(34.9)	0.50(12.7)	
1	1	3/4	-TTT-FL16-FL16-FL12	1.94(49.3)	1.94(49.3)	1.76(44.7)	1.23(31.2)	1.23(31.2)	0.96(24.4)	1.37(34.9)	0.62(15.7)	
1	1	7/8	-TTT-FL16-FL16-FL14	1.94(49.3)	1.94(49.3)	1.76(44.7)	1.23(31.2)	1.23(31.2)	1.02(25.9)	1.37(34.9)	0.72(18.3)	
1 1/4	1 1/4	1	-TTT-FL20-FL20-FL16	2.67(67.8)	2.67(67.8)	2.17(55.1)	1.62(41.2)	1.62(41.2)	1.23(31.3)	1.69(42.9)	0.88(22.4)	
1 1/2	1 1/2	1	-TTT-FL24-FL24-FL16	3.10(78.7)	3.10(78.7)	2.36(60.0)	1.97(50.0)	1.97(50.0)	1.23(31.3)	2.00(50.8)	0.88(22.4)	

Reducing Union Tees

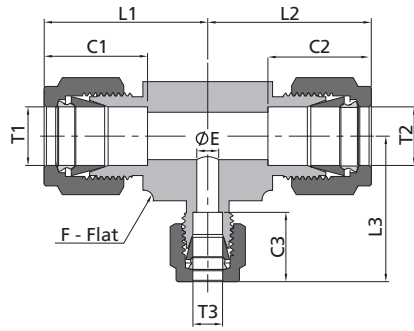

Metric Tube				Dimensions, mm (in.)								
T1-Tube O.D. (mm)	T2-Tube O.D. (mm)	T3-Tube O.D. (mm)	Basic Ordering Number	L1	L2	L3	C1	C2	C3	F	E	
3	3	6	-TTT-ML3-ML3-ML6	24.7(0.97)	24.7(0.97)	27.0(1.06)	12.9(0.51)	12.9(0.51)	15.3(0.60)	12.7(0.50)	2.4(0.09)	
6	6	3	-TTT-ML6-ML6-ML3	27.0(1.06)	27.0(1.06)	24.7(0.97)	15.3(0.60)	15.3(0.60)	12.9(0.51)	12.7(0.50)	2.4(0.09)	
6	6	8	-TTT-ML6-ML6-ML8	28.0(1.10)	28.0(1.10)	28.8(1.13)	15.3(0.60)	15.3(0.60)	16.2(0.64)	14.3(0.56)	4.8(0.19)	
8	8	6	-TTT-ML8-ML8-ML6	30.0(1.18)	30.0(1.18)	29.0(1.14)	16.2(0.64)	16.2(0.64)	15.3(0.60)	15.9(0.63)	4.8(0.19)	
8	8	12	-TTT-ML8-ML8-ML12	35.2(1.39)	35.2(1.39)	36.0(1.42)	16.2(0.64)	16.2(0.64)	22.8(0.90)	20.6(0.81)	6.4(0.25)	
10	10	6	-TTT-ML10-ML10-ML6	31.5(1.24)	31.5(1.24)	29.9(1.18)	17.2(0.68)	17.2(0.68)	15.3(0.60)	17.5(0.69)	4.8(0.19)	
10	10	8	-TTT-ML10-ML10-ML8	31.5(1.24)	31.5(1.24)	30.7(1.21)	17.2(0.68)	17.2(0.68)	16.2(0.64)	17.5(0.69)	6.4(0.25)	
12	12	6	-TTT-ML12-ML12-ML6	36.0(1.42)	36.0(1.42)	31.8(1.25)	22.8(0.90)	22.8(0.90)	15.3(0.60)	20.6(0.81)	4.8(0.19)	
12	12	8	-TTT-ML12-ML12-ML8	36.0(1.42)	36.0(1.42)	32.0(1.26)	22.8(0.90)	22.8(0.90)	16.2(0.64)	20.6(0.81)	6.4(0.25)	
12	12	14	-TTT-ML12-ML12-ML14	38.0(1.50)	38.0(1.50)	38.0(1.50)	22.8(0.90)	22.8(0.90)	24.4(0.96)	25.4(1.00)	9.5(0.37)	
12	12	18	-TTT-ML12-ML12-ML18	39.8(1.57)	39.8(1.57)	39.8(1.57)	22.8(0.90)	22.8(0.90)	24.4(0.96)	27.0(1.06)	9.5(0.37)	
14	14	8	-TTT-ML14-ML14-ML8	38.0(1.50)	38.0(1.50)	35.5(1.40)	24.4(0.96)	24.4(0.96)	16.2(0.64)	25.4(1.00)	6.4(0.25)	
14	14	10	-TTT-ML14-ML14-ML10	38.0(1.50)	38.0(1.50)	36.7(1.44)	24.4(0.96)	24.4(0.96)	17.2(0.68)	25.4(1.00)	7.9(0.31)	
15	15	12	-TTT-ML15-ML15-ML12	38.8(1.53)	38.8(1.53)	38.8(1.53)	24.4(0.96)	24.4(0.96)	22.8(0.90)	25.4(1.00)	9.5(0.37)	
16	8	16	-TTT-ML16-ML8-ML16	38.8(1.53)	35.5(1.40)	38.8(1.53)	24.4(0.96)	16.2(0.64)	24.4(0.96)	25.4(1.00)	6.4(0.25)	
16	16	12	-TTT-ML16-ML16-ML12	38.8(1.53)	38.8(1.53)	38.9(1.53)	24.4(0.96)	24.4(0.96)	22.8(0.90)	25.4(1.00)	9.5(0.37)	
18	18	8	-TTT-ML18-ML18-ML8	39.8(1.57)	39.8(1.57)	39.0(1.54)	24.4(0.96)	24.4(0.96)	16.2(0.64)	27.0(1.06)	6.4(0.25)	
18	18	10	-TTT-ML18-ML18-ML10	39.8(1.57)	39.8(1.57)	37.4(1.47)	24.4(0.96)	24.4(0.96)	17.2(0.68)	27.0(1.06)	7.9(0.31)	
18	18	12	-TTT-ML18-ML18-ML12	39.8(1.57)	39.8(1.57)	39.8(1.57)	24.4(0.96)	24.4(0.96)	22.8(0.90)	27.0(1.06)	9.5(0.37)	
18	18	14	-TTT-ML18-ML18-ML14	39.8(1.57)	39.8(1.57)	39.8(1.57)	24.4(0.96)	24.4(0.96)	24.4(0.96)	27.0(1.06)	11.1(0.44)	
20	20	14	-TTT-ML20-ML20-ML14	44.6(1.76)	44.6(1.76)	44.6(1.76)	26.0(1.02)	26.0(1.02)	24.4(0.96)	34.9(1.37)	11.1(0.44)	
22	22	12	-TTT-ML22-ML22-ML12	44.6(1.76)	44.6(1.76)	44.6(1.76)	26.0(1.02)	26.0(1.02)	22.8(0.90)	34.9(1.37)	9.5(0.37)	
25	25	12	-TTT-ML25-ML25-ML12	49.1(1.93)	49.1(1.93)	44.7(1.76)	31.3(1.23)	31.3(1.23)	22.8(0.90)	34.9(1.37)	9.5(0.37)	

Union Crosses

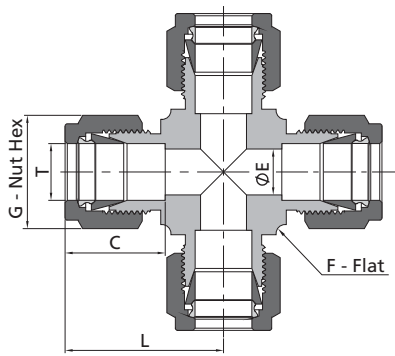

Fractional Tube						
T-Tube O.D. (in.)	Basic Ordering Number	Dimensions, in. (mm)				
		L	C	G	F	E
1/8	-C-FL2	0.88(22.4)	0.50(12.7)	0.44(11.1)	0.37(9.5)	0.09(2.3)
3/16	-C-FL3	0.96(24.4)	0.54(13.7)	0.50(12.7)	0.44(11.1)	0.12(3.0)
1/4	-C-FL4	1.06(26.9)	0.60(15.2)	0.56(14.3)	0.50(12.7)	0.19(4.8)
5/16	-C-FL5	1.17(29.7)	0.64(16.2)	0.63(15.9)	0.63(15.9)	0.25(6.4)
3/8	-C-FL6	1.20(30.5)	0.66(16.8)	0.69(17.5)	0.63(15.9)	0.28(7.1)
1/2	-C-FL8	1.42(36.1)	0.90(22.9)	0.87(22.2)	0.81(20.6)	0.41(10.4)
5/8	-C-FL10	1.53(38.8)	0.96(24.4)	1.00(25.4)	1.0(25.4)	0.50(12.7)
3/4	-C-FL12	1.57(39.9)	0.96(24.4)	1.13(28.6)	1.06(27.0)	0.62(15.7)
7/8	-C-FL14	1.76(44.7)	1.02(25.9)	1.25(31.8)	1.37(34.9)	0.72(18.3)
1	-C-FL16	1.93(49.0)	1.23(31.2)	1.50(38.1)	1.37(34.9)	0.88(22.4)

Metric Tube						
T-Tube O.D. (mm)	Basic Ordering Number	Dimensions, mm (in.)				
		L	C	G	F	E
3	-C-ML3	22.3(0.88)	12.9(0.51)	12.0(0.47)	9.5(0.37)	2.4(0.09)
4	-C-ML4	25.4(1.00)	13.7(0.54)	12.0(0.47)	12.7(0.50)	2.4(0.09)
6	-C-ML6	27.0(1.06)	15.3(0.60)	14.0(0.55)	12.7(0.50)	4.8(0.19)
8	-C-ML8	29.9(1.18)	16.2(0.64)	16.0(0.63)	15.9(0.63)	6.4(0.25)
10	-C-ML10	33.5(1.32)	17.2(0.68)	19.0(0.75)	20.6(0.81)	7.9(0.31)
12	-C-ML12	36.0(1.42)	22.8(0.90)	22.0(0.87)	20.6(0.81)	9.5(0.37)
16	-C-ML16	37.0(1.46)	24.4(0.96)	25.0(0.98)	23.8(0.94)	12.7(0.50)
18	-C-ML18	38.3(1.51)	24.4(0.96)	30.0(1.18)	27.0(1.06)	15.1(0.59)
20	-C-ML20	44.6(1.76)	26.0(1.02)	32.0(1.26)	34.9(1.37)	15.9(0.63)
22	-C-ML22	44.7(1.76)	26.0(1.02)	32.0(1.26)	34.9(1.37)	18.3(0.72)
25	-C-ML25	49.2(1.94)	31.3(1.23)	38.0(1.50)	34.9(1.37)	21.8(0.86)

Caps

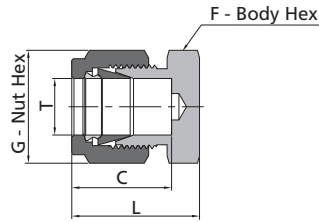

Fractional Tube					
T-Tube O.D. (in.)	Basic Ordering Number	Dimensions, in. (mm)			
		L	C	G	F
1/16	-TC-FL1	0.59(15.0)	0.34(8.6)	0.31(7.9)	0.31(7.9)
1/8	-TC-FL2	0.79(20.1)	0.50(12.7)	0.44(11.1)	0.44(11.1)
3/16	-TC-FL3	0.84(21.3)	0.54(13.7)	0.50(12.7)	0.44(11.1)
1/4	-TC-FL4	0.92(23.4)	0.60(15.2)	0.56(14.3)	0.50(12.7)
5/16	-TC-FL5	0.96(24.4)	0.64(16.3)	0.63(15.9)	0.56(14.3)
3/8	-TC-FL6	1.01(25.7)	0.66(16.8)	0.69(17.5)	0.63(15.9)
1/2	-TC-FL8	1.15(29.2)	0.90(22.9)	0.87(22.2)	0.81(20.6)
5/8	-TC-FL10	1.18(30.0)	0.96(24.4)	1.00(25.4)	0.94(23.8)
3/4	-TC-FL12	1.24(31.5)	0.96(24.4)	1.13(28.6)	1.06(27.0)
7/8	-TC-FL14	1.34(34.0)	1.02(25.9)	1.25(31.8)	1.19(30.2)
1	-TC-FL16	1.51(38.4)	1.23(31.2)	1.50(38.1)	1.37(34.9)
1 1/8	-TC-FL18	1.51(38.4)	1.44(36.7)	1.75(44.5)	1.63(41.3)
1 1/4	-TC-FL20	2.10(53.3)	1.62(41.1)	1.87(47.6)	1.75(44.5)
1 1/2	-TC-FL24	2.54(64.5)	1.97(50.0)	2.25(57.2)	2.13(54.0)

Metric Tube					
T-Tube O.D. (mm)	Basic Ordering Number	Dimensions, mm (in.)			
		L	C	G	F
2	-TC-ML2	20.1(0.79)	12.9(0.51)	12.0(0.47)	12.0(0.47)
3	-TC-ML3	20.1(0.79)	12.9(0.51)	12.0(0.47)	12.0(0.47)
4	-TC-ML4	21.3(0.84)	13.7(0.54)	12.0(0.47)	12.0(0.47)
6	-TC-ML6	23.1(0.91)	15.3(0.60)	14.0(0.55)	14.0(0.55)
8	-TC-ML8	24.5(0.96)	16.2(0.64)	16.0(0.63)	15.0(0.59)
10	-TC-ML10	26.6(1.05)	17.2(0.68)	19.0(0.75)	18.0(0.71)
12	-TC-ML12	29.1(1.15)	22.8(0.90)	22.0(0.87)	22.0(0.87)
14	-TC-ML14	29.9(1.18)	24.4(0.96)	25.0(0.98)	24.0(0.94)
15	-TC-ML15	29.9(1.18)	24.4(0.96)	25.0(0.98)	24.0(0.94)
16	-TC-ML16	29.9(1.18)	24.4(0.96)	25.0(0.98)	24.0(0.94)
18	-TC-ML18	31.4(1.24)	24.4(0.96)	30.0(1.18)	27.0(1.06)
20	-TC-ML20	34.0(1.34)	26.0(1.02)	32.0(1.26)	30.0(1.18)
22	-TC-ML22	34.0(1.34)	26.0(1.02)	32.0(1.26)	30.0(1.18)
25	-TC-ML25	38.5(1.52)	31.3(1.23)	38.0(1.50)	35.0(1.38)
28	-TC-ML28	48.5(1.91)	36.6(1.44)	46.0(1.81)	41.0(1.61)
30	-TC-ML30	53.4(2.10)	39.6(1.56)	50.0(1.97)	46.0(1.81)
32	-TC-ML32	55.8(2.20)	42.0(1.65)	50.0(1.97)	46.0(1.81)
38	-TC-ML38	65.4(2.57)	49.4(1.94)	60.0(2.36)	55.0(2.17)

Plugs

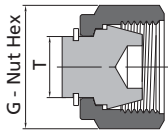

Fractional Tube		
T-Tube O.D. (in.)	Basic Ordering Number	Dimensions, in. (mm)
		G
1/16	-TP-FL1	0.31(7.9)
1/8	-TP-FL2	0.44(11.1)
3/16	-TP-FL3	0.50(12.7)
1/4	-TP-FL4	0.56(14.3)
5/16	-TP-FL5	0.63(15.9)
3/8	-TP-FL6	0.69(17.5)
1/2	-TP-FL8	0.87(22.2)
5/8	-TP-FL10	1.00(25.4)
3/4	-TP-FL12	1.13(28.6)
7/8	-TP-FL14	1.25(31.8)
1	-TP-FL16	1.50(38.1)
1 1/4	-TP-FL20	1.87(47.6)
1 1/2	-TP-FL24	2.25(57.2)

Metric Tube		
T-Tube O.D. (mm)	Basic Ordering Number	Dimensions, mm (in.)
		G
2	-TP-ML2	12.0(0.47)
3	-TP-ML3	12.0(0.47)
4	-TP-ML4	12.0(0.47)
6	-TP-ML6	14.0(0.55)
8	-TP-ML8	16.0(0.63)
10	-TP-ML10	19.0(0.75)
12	-TP-ML12	22.0(0.87)
14	-TP-ML14	25.0(0.98)
15	-TP-ML15	25.0(0.98)
16	-TP-ML16	25.0(0.98)
18	-TP-ML18	30.0(1.18)
20	-TP-ML20	32.0(1.26)
22	-TP-ML22	32.0(1.26)
25	-TP-ML25	38.0(1.50)
28	-TP-ML28	46.0(1.81)
30	-TP-ML30	50.0(1.97)
32	-TP-ML32	50.0(1.97)
38	-TP-ML38	60.0(2.36)

Vent Protectors

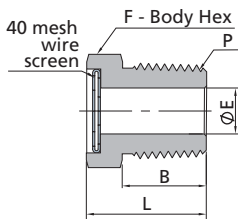

40 mesh 300 series stainless steel wire screen assembly

NPT Thread					
P-NPT Size	Ordering Number	Dimensions, in. (mm)			
		L	F	B	E
1/8	-VPF-NS2	0.56(14.2)	0.50(12.7)	0.38(9.7)	0.19(4.8)
1/4	-VPF-NS4	0.78(19.8)	0.56(14.3)	0.56(14.2)	0.28(7.1)
3/8	-VPF-NS6	0.81(20.6)	0.69(17.5)	0.56(14.2)	0.41(10.4)
1/2	-VPF-NS8	1.03(26.2)	0.87(22.2)	0.75(19.1)	0.50(12.7)
3/4	-VPF-NS12	1.06(26.9)	1.06(27.0)	0.76(19.2)	0.72(18.3)
1	-VPF-NS16	1.37(34.8)	1.37(34.9)	0.94(23.9)	0.88(22.4)

To order brass, replace SS in the ordering number with B
Example: B-VPF-NS2

Lapped Flange Connectors

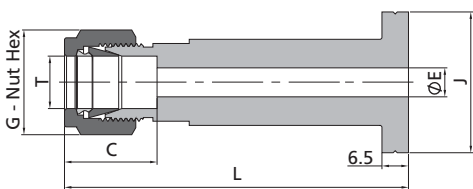

- Standard material is 316 or Monel.
- The flange ends are used with NPS 1/2 lap joint pipe flanges.
- The flange ends are dimensioned to meet "ANSI B16.5 Class 2500" flange specifications.
- The Flange Seal A means surface finish Ra 3.2-6.3 µm, the flange Seal B means Ra 6.3-12.5 µm.

Fractional Tube							
T-Tube O.D. (in.)	Flange Seal	Basic Ordering Number	Dimensions, in. (mm)				
			L	G	C	E	J
1/4	A	-LFC-FL4A	3.18(80.8)	0.56(14.3)	0.60(15.2)	0.19(4.8)	1.36(34.5)
1/4	B	-LFC-FL4B	3.18(80.8)	0.56(14.3)	0.60(15.2)	0.19(4.8)	1.36(34.5)
3/8	A	-LFC-FL6A	3.24(82.3)	0.69(17.5)	0.66(16.8)	0.28(7.1)	1.36(34.5)
3/8	B	-LFC-FL6B	3.24(82.3)	0.69(17.5)	0.66(16.8)	0.28(7.1)	1.36(34.5)
1/2	A	-LFC-FL8A	3.35(85.1)	0.87(22.2)	0.90(22.9)	0.31(7.9)	1.36(34.5)
1/2	B	-LFC-FL8B	3.35(85.1)	0.87(22.2)	0.90(22.9)	0.31(7.9)	1.36(34.5)

Metric Tube							
T-Tube O.D. (mm)	Flange Seal	Basic Ordering Number	Dimensions, mm (in.)				
			L	G	C	E	J
10	A	-LFC-ML10A	82.6(3.25)	19.0(0.75)	17.2(0.68)	7.9(0.31)	34.5(1.36)
10	B	-LFC-ML10B	82.6(3.25)	19.0(0.75)	17.2(0.68)	7.9(0.31)	34.5(1.36)

Nuts

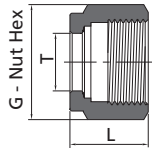

Fractional Tube			
T-Tube O.D. (in.)	Basic Ordering Number	Dimensions, in. (mm)	
		L	G
1/16	-N-FL1	0.31(7.9)	0.31(7.9)
1/8	-N-FL2	0.47(11.9)	0.44(11.1)
3/16	-N-FL3	0.47(11.9)	0.50(12.7)
1/4	-N-FL4	0.50(12.7)	0.56(14.3)
5/16	-N-FL5	0.53(13.5)	0.63(15.9)
3/8	-N-FL6	0.56(14.2)	0.69(17.5)
1/2	-N-FL8	0.69(17.5)	0.87(22.2)
5/8	-N-FL10	0.69(17.5)	1.00(25.4)
3/4	-N-FL12	0.69(17.5)	1.13(28.6)
7/8	-N-FL14	0.69(17.5)	1.25(31.8)
1	-N-FL16	0.81(20.6)	1.50(38.1)
1 1/8	-N-FL18	1.21(30.8)	1.75(44.5)
1 1/4	-N-FL20	1.25(31.8)	1.87(47.6)
1 1/2	-N-FL24	1.50(38.1)	2.25(57.2)

Metric Tube			
T-Tube O.D. (mm)	Basic Ordering Number	Dimensions, mm (in.)	
		L	G
2	-N-ML2	11.9(0.47)	12.0(0.47)
3	-N-ML3	11.9(0.47)	12.0(0.47)
4	-N-ML4	11.9(0.47)	12.0(0.47)
6	-N-ML6	12.7(0.50)	14.0(0.55)
8	-N-ML8	13.5(0.53)	16.0(0.63)
10	-N-ML10	15.1(0.59)	19.0(0.75)
12	-N-ML12	17.4(0.69)	22.0(0.87)
14	-N-ML14	17.4(0.69)	25.0(0.98)
15	-N-ML15	17.4(0.69)	25.0(0.98)
16	-N-ML16	17.4(0.69)	25.0(0.98)
18	-N-ML18	17.4(0.69)	30.0(1.18)
20	-N-ML20	17.4(0.69)	32.0(1.26)
22	-N-ML22	17.4(0.69)	32.0(1.26)
25	-N-ML25	20.6(0.81)	38.0(1.50)
28	-N-ML28	30.6(1.20)	46.0(1.81)
30	-N-ML30	32.7(1.29)	50.0(1.97)
32	-N-ML32	34.4(1.35)	50.0(1.97)
38	-N-ML38	40.6(1.60)	60.0(2.36)

Knurled Nuts

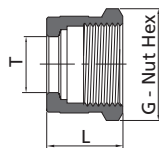

To order a knurled nut add **-K** to the nut ordering number.
Example: B-KN-FL4

Male Nuts

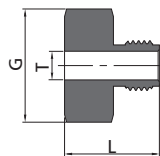

Fractional Tube			
T-Tube O.D. (in.)	Basic Ordering Number	Dimensions, in. (mm)	
		L	G
1/16	-MN-FL1	0.38(9.7)	0.25(6.4)
1/8	-MN-FL2	0.53(13.5)	0.37(9.5)
1/4	-MN-FL4	0.62(15.7)	0.50(12.7)
1/2	-MN-FL8	0.87(22.1)	0.94(23.8)

Metric Tube			
T-Tube O.D. (mm)	Basic Ordering Number	Dimensions, mm (in.)	
		L	G
3	-MN-ML3	13.5(0.53)	10.0(0.39)
6	-MN-ML6	15.7(0.62)	14.0(0.55)
10	-MN-ML10	22.1(0.87)	22.0(0.87)
12	-MN-ML12	22.1(0.87)	24.0(0.94)

Front Ferrules

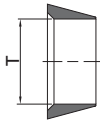

Fractional Tube	
T-Tube O.D. (in.)	Basic Ordering Number
1/16	-FF-FL1
1/8	-FF-FL2
3/16	-FF-FL3
1/4	-FF-FL4
5/16	-FF-FL5
3/8	-FF-FL6
1/2	-FF-FL8
5/8	-FF-FL10
3/4	-FF-FL12
7/8	-FF-FL14
1	-FF-FL16
1 1/8	-FF-FL18*
1 1/4	-FF-FL20*
1 1/2	-FF-FL24*

Metric Tube	
T-Tube O.D. (mm)	Basic Ordering Number
2	-FF-ML2
3	-FF-ML3
4	-FF-ML4
6	-FF-ML6
8	-FF-ML8
10	-FF-ML10
12	-FF-ML12
14	-FF-ML14
15	-FF-ML15
16	-FF-ML16
18	-FF-ML18
20	-FF-ML20
22	-FF-ML22
25	-FF-ML25
28	-FF-ML28*
30	-FF-ML30*
32	-FF-ML32*
38	-FF-ML38*

* Stainless steel front ferrules over 1 in. or 25 mm are PFA coated.

Rear Ferrules

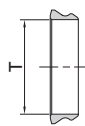

Fractional Tube	
T-Tube O.D. (in.)	Basic Ordering Number
1/16	-RF-FL1
1/8	-RF-FL2
3/16	-RF-FL3
1/4	-RF-FL4
5/16	-RF-FL5
3/8	-RF-FL6
1/2	-RF-FL8
5/8	-RF-FL10
3/4	-RF-FL12
7/8	-RF-FL14
1	-RF-FL16
1 1/8	-RF-FL18*
1 1/4	-RF-FL20*
1 1/2	-RF-FL24*

Metric Tube	
T-Tube O.D. (mm)	Basic Ordering Number
2	-RF-ML2
3	-RF-ML3
4	-RF-ML4
6	-RF-ML6
8	-RF-ML8
10	-RF-ML10
12	-RF-ML12
14	-RF-ML14
15	-RF-ML15
16	-RF-ML16
18	-RF-ML18
20	-RF-ML20
22	-RF-ML22
25	-RF-ML25
28	-RF-ML28*
30	-RF-ML30*
32	-RF-ML32*
38	-RF-ML38*

* Stainless steel rear ferrules over 1 in. or 25 mm are PFA coated.

Nuts + Ferrules

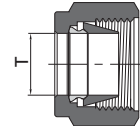

Fractional Tube	
T-Tube O.D. (in.)	Basic Ordering Number
1/16	-NFR-FL1
1/8	-NFR-FL2
3/16	-NFR-FL3
1/4	-NFR-FL4
5/16	-NFR-FL5
3/8	-NFR-FL6
1/2	-NFR-FL8
5/8	-NFR-FL10
3/4	-NFR-FL12
7/8	-NFR-FL14
1	-NFR-FL16
1 1/8	-NFR-FL18
1 1/4	-NFR-FL20
1 1/2	-NFR-FL24

Metric Tube	
T-Tube O.D. (mm)	Basic Ordering Number
2	-NFR-ML2
3	-NFR-ML3
4	-NFR-ML4
6	-NFR-ML6
8	-NFR-ML8
10	-NFR-ML10
12	-NFR-ML12
14	-NFR-ML14
15	-NFR-ML15
16	-NFR-ML16
18	-NFR-ML18
20	-NFR-ML20
22	-NFR-ML22
25	-NFR-ML25
28	-NFR-ML28
30	-NFR-ML30
32	-NFR-ML32
38	-NFR-ML38

Nuts - Ferrule Sets



Each Nut-Ferrule Set contains 5 nuts, 5 front ferrules and 5 rear ferrules.

Fractional Tube	
T-Tube O.D. (in.)	Basic Ordering Number
1/16	-NFS-FL1
1/8	-NFS-FL2
3/16	-NFS-FL3
1/4	-NFS-FL4
5/16	-NFS-FL5
3/8	-NFS-FL6
1/2	-NFS-FL8
5/8	-NFS-FL10
3/4	-NFS-FL12

Metric Tube	
T-Tube O.D. (mm)	Basic Ordering Number
2	-NFS-ML2
3	-NFS-ML3
4	-NFS-ML4
6	-NFS-ML6
8	-NFS-ML8
10	-NFS-ML10
12	-NFS-ML12
14	-NFS-ML14
15	-NFS-ML15
16	-NFS-ML16
18	-NFS-ML18

Ferrule Sets



Each Ferrule Set contains 10 front ferrules and 10 rear ferrules.

Fractional Tube	
T-Tube O.D. (in.)	Basic Ordering Number
1/16	-FRS-FL1
1/8	-FRS-FL2
3/16	-FRS-FL3
1/4	-FRS-FL4
5/16	-FRS-FL5
3/8	-FRS-FL6
1/2	-FRS-FL8
5/8	-FRS-FL10
3/4	-FRS-FL12

Metric Tube	
T-Tube O.D. (mm)	Basic Ordering Number
2	-FRS-ML2
3	-FRS-ML3
4	-FRS-ML4
6	-FRS-ML6
8	-FRS-ML8
10	-FRS-ML10
12	-FRS-ML12
14	-FRS-ML14
15	-FRS-ML15
16	-FRS-ML16
18	-FRS-ML18

Reducers

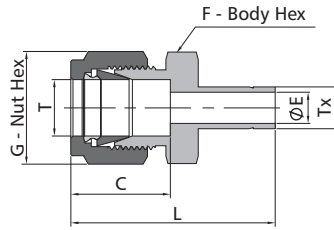

Tube Fittings

Fractional Tube			Dimensions, in. (mm)				
T-Tube O.D. (in.)	Tx-Tube O.D. (in.)	Basic Ordering Number	L	C	G	F	E
1/16	1/8	-R-FL1-FT2	1.15(29.2)	0.34(8.6)	0.31(7.9)	0.31(7.9)	0.05(1.3)
1/16	3/16	-R-FL1-FT3	1.18(30.0)	0.34(8.6)	0.31(7.9)	0.31(7.9)	0.05(1.3)
1/16	1/4	-R-FL1-FT4	1.24(31.5)	0.34(8.6)	0.31(7.9)	0.31(7.9)	0.05(1.3)
1/8	1/16	-R-FL2-FT1	1.14(29.0)	0.50(12.7)	0.44(11.1)	0.44(11.1)	0.03(0.8)
1/8	1/8	-R-FL2-FT2	1.32(33.5)	0.50(12.7)	0.44(11.1)	0.44(11.1)	0.08(2.0)
1/8	3/16	-R-FL2-FT3	1.35(34.3)	0.50(12.7)	0.44(11.1)	0.44(11.1)	0.09(2.3)
1/8	1/4	-R-FL2-FT4	1.42(36.1)	0.50(12.7)	0.44(11.1)	0.44(11.1)	0.09(2.3)
1/8	3/8	-R-FL2-FT6	1.48(37.6)	0.50(12.7)	0.44(11.1)	0.44(11.1)	0.09(2.3)
1/8	1/2	-R-FL2-FT8	1.74(44.2)	0.50(12.7)	0.44(11.1)	0.56(14.3)	0.09(2.3)
3/16	1/8	-R-FL3-FT2	1.37(34.8)	0.54(13.7)	0.50(12.7)	0.44(11.1)	0.08(2.0)
3/16	1/4	-R-FL3-FT4	1.46(37.1)	0.54(13.7)	0.50(12.7)	0.44(11.1)	0.12(3.0)
1/4	1/8	-R-FL4-FT2	1.45(36.8)	0.60(15.2)	0.56(14.3)	0.50(12.7)	0.08(2.0)
1/4	3/16	-R-FL4-FT3	1.48(37.6)	0.60(15.2)	0.56(14.3)	0.50(12.7)	0.12(3.0)
1/4	1/4	-R-FL4-FT4	1.54(39.1)	0.60(15.2)	0.56(14.3)	0.50(12.7)	0.17(4.3)
1/4	5/16	-R-FL4-FT5	1.57(39.9)	0.60(15.2)	0.56(14.3)	0.50(12.7)	0.19(4.8)
1/4	3/8	-R-FL4-FT6	1.60(40.6)	0.60(15.2)	0.56(14.3)	0.50(12.7)	0.19(4.8)
1/4	1/2	-R-FL4-FT8	1.82(46.2)	0.60(15.2)	0.56(14.3)	0.56(14.3)	0.19(4.8)
1/4	5/8	-R-FL4-FT10	1.89(48.0)	0.60(15.2)	0.56(14.3)	0.69(17.5)	0.19(4.8)
1/4	3/4	-R-FL4-FT12	1.88(47.8)	0.60(15.2)	0.56(14.3)	0.81(20.6)	0.19(4.8)
5/16	3/8	-R-FL5-FT6	1.65(41.9)	0.64(16.3)	0.63(15.9)	0.56(14.3)	0.25(6.4)
5/16	1/2	-R-FL5-FT8	1.87(47.5)	0.64(16.3)	0.63(15.9)	0.56(14.3)	0.25(6.4)
3/8	1/4	-R-FL6-FT4	1.63(41.4)	0.66(16.8)	0.69(17.5)	0.63(15.9)	0.17(4.3)
3/8	3/8	-R-FL6-FT6	1.70(43.2)	0.66(16.8)	0.69(17.5)	0.63(15.9)	0.27(6.9)
3/8	1/2	-R-FL6-FT8	1.91(48.5)	0.66(16.8)	0.69(17.5)	0.63(15.9)	0.28(7.1)
3/8	5/8	-R-FL6-FT10	1.98(50.3)	0.66(16.8)	0.69(17.5)	0.69(17.5)	0.28(7.1)
3/8	3/4	-R-FL6-FT12	1.98(50.3)	0.66(16.8)	0.69(17.5)	0.81(20.6)	0.28(7.1)
1/2	1/4	-R-FL8-FT4	1.77(45.0)	0.90(22.9)	0.87(22.2)	0.81(20.6)	0.17(4.3)
1/2	3/8	-R-FL8-FT6	1.84(46.7)	0.90(22.9)	0.87(22.2)	0.81(20.6)	0.27(6.9)
1/2	1/2	-R-FL8-FT8	2.06(52.3)	0.90(22.9)	0.87(22.2)	0.81(20.6)	0.37(9.4)
1/2	5/8	-R-FL8-FT10	2.12(53.8)	0.90(22.9)	0.87(22.2)	0.81(20.6)	0.41(10.4)
1/2	3/4	-R-FL8-FT12	2.12(53.8)	0.90(22.9)	0.87(22.2)	0.81(20.6)	0.41(10.4)
1/2	1	-R-FL8-FT16	2.37(60.2)	0.90(22.9)	0.87(22.2)	1.06(27.0)	0.41(10.4)
5/8	3/4	-R-FL10-FT12	2.15(54.6)	0.96(24.4)	1.00(25.4)	0.94(23.8)	0.50(12.7)
5/8	7/8	-R-FL10-FT14	2.21(56.1)	0.96(24.4)	1.00(25.4)	0.94(23.8)	0.50(12.7)
5/8	1	-R-FL10-FT16	2.40(61.0)	0.96(24.4)	1.00(25.4)	1.06(27.0)	0.50(12.7)
3/4	1/2	-R-FL12-FT8	2.15(54.6)	0.96(24.4)	1.13(28.6)	1.06(27.0)	0.37(9.4)
3/4	1	-R-FL12-FT16	2.46(62.5)	0.96(24.4)	1.13(28.6)	1.06(27.0)	0.62(15.7)
1	1 1/4	-R-FL16-FT20	3.17(80.5)	1.23(31.2)	1.50(38.1)	1.37(34.9)	0.88(22.4)
1	1 1/2	-R-FL16-FT24	3.51(89.2)	1.23(31.2)	1.50(38.1)	1.63(41.3)	0.88(22.4)
1	2	-R-FL16-FT32	4.43(112.5)	1.23(31.2)	1.50(38.1)	2.13(54.0)	0.88(22.4)
1 1/4	1 1/2	-R-FL20-FT24	4.10(104.1)	1.62(41.1)	1.87(47.6)	1.87(47.6)	1.09(27.7)

Reducers

Tube Fittings

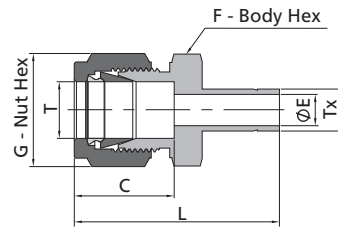

Metric Tube			Dimensions, mm (in.)				
T-Tube O.D. (mm)	Tx-Tube O.D. (mm)	Basic Ordering Number	L	C	G	F	E
2	3	-R-ML2-MT3	33.5(1.32)	12.9(0.51)	12.0(0.47)	12.0(0.47)	1.7(0.07)
3	4	-R-ML3-MT4	35.0(1.38)	12.9(0.51)	12.0(0.47)	12.0(0.47)	2.4(0.09)
3	6	-R-ML3-MT6	36.1(1.42)	12.9(0.51)	12.0(0.47)	12.0(0.47)	2.4(0.09)
3	10	-R-ML3-MT10	38.4(1.51)	12.9(0.51)	12.0(0.47)	14.0(0.55)	2.4(0.09)
4	6	-R-ML4-MT6	37.1(1.46)	13.7(0.54)	12.0(0.47)	12.0(0.47)	2.4(0.09)
6	3	-R-ML6-MT3	36.9(1.45)	15.3(0.60)	14.0(0.55)	14.0(0.55)	1.9(0.07)
6	8	-R-ML6-MT8	39.9(1.57)	15.3(0.60)	14.0(0.55)	14.0(0.55)	4.8(0.19)
6	10	-R-ML6-MT10	40.7(1.60)	15.3(0.60)	14.0(0.55)	14.0(0.55)	4.8(0.19)
6	12	-R-ML6-MT12	46.3(1.82)	15.3(0.60)	14.0(0.55)	14.0(0.55)	4.8(0.19)
6	18	-R-ML6-MT18	49.6(1.95)	15.3(0.60)	14.0(0.55)	22.0(0.87)	4.8(0.19)
8	6	-R-ML8-MT6	40.3(1.59)	16.2(0.64)	16.0(0.63)	15.0(0.59)	4.1(0.16)
8	10	-R-ML8-MT10	42.0(1.65)	16.2(0.64)	16.0(0.63)	15.0(0.59)	6.4(0.25)
8	12	-R-ML8-MT12	47.6(1.87)	16.2(0.64)	16.0(0.63)	15.0(0.59)	6.4(0.25)
10	6	-R-ML10-MT6	42.4(1.67)	17.2(0.68)	19.0(0.75)	18.0(0.71)	4.1(0.16)
10	8	-R-ML10-MT8	43.4(1.71)	17.2(0.68)	19.0(0.75)	18.0(0.71)	5.6(0.22)
10	12	-R-ML10-MT12	49.8(1.96)	17.2(0.68)	19.0(0.75)	18.0(0.71)	7.9(0.31)
10	15	-R-ML10-MT15	51.3(2.02)	17.2(0.68)	19.0(0.75)	18.0(0.71)	7.9(0.31)
10	18	-R-ML10-MT18	51.3(2.02)	17.2(0.68)	19.0(0.75)	22.0(0.87)	7.9(0.31)
12	6	-R-ML12-MT6	44.9(1.77)	22.8(0.90)	22.0(0.87)	22.0(0.87)	4.1(0.16)
12	8	-R-ML12-MT8	45.9(1.81)	22.8(0.90)	22.0(0.87)	22.0(0.87)	5.6(0.22)
12	10	-R-ML12-MT10	46.7(1.84)	22.8(0.90)	22.0(0.87)	22.0(0.87)	7.1(0.28)
12	16	-R-ML12-MT16	53.8(2.12)	22.8(0.90)	22.0(0.87)	22.0(0.87)	9.5(0.37)
12	18	-R-ML12-MT18	53.8(2.12)	22.8(0.90)	22.0(0.87)	22.0(0.87)	9.5(0.37)
12	20	-R-ML12-MT20	56.1(2.21)	22.8(0.90)	22.0(0.87)	22.0(0.87)	9.5(0.37)
12	22	-R-ML12-MT22	56.1(2.21)	22.8(0.90)	22.0(0.87)	24.0(0.94)	9.5(0.37)
12	25	-R-ML12-MT25	62.4(2.46)	22.8(0.90)	22.0(0.87)	27.0(1.06)	9.5(0.37)
16	12	-R-ML16-MT12	53.0(2.09)	24.4(0.96)	25.0(0.98)	24.0(0.94)	8.8(0.35)
18	12	-R-ML18-MT12	54.6(2.15)	24.4(0.96)	30.0(1.18)	27.0(1.06)	8.8(0.35)
18	16	-R-ML18-MT16	56.1(2.21)	24.4(0.96)	30.0(1.18)	27.0(1.06)	12.0(0.47)
18	20	-R-ML18-MT20	57.6(2.27)	24.4(0.96)	30.0(1.18)	27.0(1.06)	15.1(0.59)
18	22	-R-ML18-MT22	57.6(2.27)	24.4(0.96)	30.0(1.18)	27.0(1.06)	15.1(0.59)
18	25	-R-ML18-MT25	62.4(2.46)	24.4(0.96)	30.0(1.18)	27.0(1.06)	15.1(0.59)
20	16	-R-ML20-MT16	57.9(2.28)	26.0(1.02)	32.0(1.26)	30.0(1.18)	12.0(0.47)
20	18	-R-ML20-MT18	57.9(2.28)	26.0(1.02)	32.0(1.26)	30.0(1.18)	13.9(0.55)
20	22	-R-ML20-MT22	59.4(2.34)	26.0(1.02)	32.0(1.26)	30.0(1.18)	15.9(0.63)
20	25	-R-ML20-MT25	64.2(2.53)	26.0(1.02)	32.0(1.26)	30.0(1.18)	15.8(0.62)
22	18	-R-ML22-MT18	57.9(2.28)	26.0(1.02)	32.0(1.26)	30.0(1.18)	13.9(0.55)
22	20	-R-ML22-MT20	59.4(2.34)	26.0(1.02)	32.0(1.26)	30.0(1.18)	15.5(0.61)
22	25	-R-ML22-MT25	64.2(2.53)	26.0(1.02)	32.0(1.26)	30.0(1.18)	18.3(0.72)
25	18	-R-ML25-MT18	63.1(2.48)	31.3(1.23)	38.0(1.50)	35.0(1.38)	13.9(0.55)
25	20	-R-ML25-MT20	64.6(2.54)	31.3(1.23)	38.0(1.50)	35.0(1.38)	15.5(0.61)

Reducers

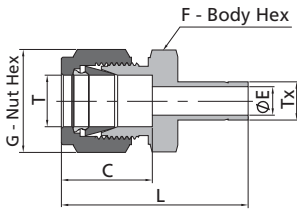

Metric Tube			Fractional Tube				
T-Tube O.D. (mm)	Tx-Tube O.D. (in.)	Basic Ordering Number	Dimensions, mm (in.)				
			L	C	G	F	E
2	1/8	-R-ML2-FT2	33.5(1.32)	12.9(0.51)	12.0(0.47)	12.0(0.47)	1.7(0.07)
3	1/8	-R-ML3-FT2	33.5(1.32)	12.9(0.51)	12.0(0.47)	12.0(0.47)	2.0(0.08)
3	1/4	-R-ML3-FT4	36.1(1.42)	12.9(0.51)	12.0(0.47)	12.0(0.47)	2.4(0.09)
4	1/4	-R-ML4-FT4	37.1(1.46)	13.7(0.54)	12.0(0.47)	12.0(0.47)	2.4(0.09)
6	1/8	-R-ML6-FT2	36.9(1.45)	15.3(0.60)	14.0(0.55)	14.0(0.55)	2.0(0.08)
6	1/4	-R-ML6-FT4	39.2(1.54)	15.3(0.60)	14.0(0.55)	14.0(0.55)	4.4(0.17)
6	5/16	-R-ML6-FT5	39.9(1.57)	15.3(0.60)	14.0(0.55)	14.0(0.55)	4.8(0.19)
6	3/8	-R-ML6-FT6	40.7(1.60)	15.3(0.60)	14.0(0.55)	14.0(0.55)	4.8(0.19)
6	1/2	-R-ML6-FT8	46.3(1.82)	15.3(0.60)	14.0(0.55)	14.0(0.55)	4.8(0.19)
8	1/4	-R-ML8-FT4	40.3(1.59)	16.2(0.64)	16.0(0.63)	15.0(0.59)	4.4(0.17)
8	3/8	-R-ML8-FT6	42.0(1.65)	16.2(0.64)	16.0(0.63)	15.0(0.59)	6.4(0.25)
8	1/2	-R-ML8-FT8	47.6(1.87)	16.2(0.64)	16.0(0.63)	15.0(0.59)	6.4(0.25)
10	3/8	-R-ML10-FT6	44.4(1.75)	17.2(0.68)	19.0(0.75)	18.0(0.71)	6.8(0.27)
10	1/2	-R-ML10-FT8	49.8(1.96)	17.2(0.68)	19.0(0.75)	18.0(0.71)	7.9(0.31)
12	1/2	-R-ML12-FT8	52.3(2.06)	22.8(0.90)	22.0(0.87)	22.0(0.87)	9.3(0.37)
12	3/4	-R-ML12-FT12	53.8(2.12)	22.8(0.90)	22.0(0.87)	22.0(0.87)	9.5(0.37)
18	3/4	-R-ML18-FT12	56.1(2.21)	24.4(0.96)	30.0(1.18)	27.0(1.06)	14.7(0.58)
18	1	-R-ML18-FT16	62.4(2.46)	24.4(0.96)	30.0(1.18)	27.0(1.06)	15.1(0.59)
25	1	-R-ML25-FT16	69.5(2.74)	31.3(1.23)	38.0(1.50)	35.0(1.38)	20.2(0.80)

Fractional Tube			Metric Tube				
T-Tube O.D. (in.)	Tx-Tube O.D. (mm)	Basic Ordering Number	Dimensions, in. (mm)				
			L	C	G	F	E
1/8	6	-R-FL2-MT6	1.42(36.1)	0.50(12.7)	0.44(11.1)	0.44(11.1)	0.09(2.3)

Bulkhead Reducers

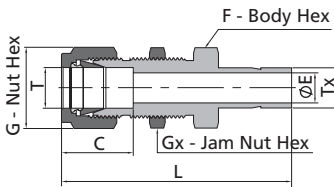

Fractional Tube			Metric Tube					
T-Tube O.D. (in.)	Tx-Tube O.D. (in.)	Basic Ordering Number	Dimensions, in. (mm)					
			L	C	G	F	Gx	E
1/8	1/8	-BR-FL2-FT2	1.95(49.5)	0.50(12.7)	0.44(11.1)	0.50(12.7)	0.50(12.7)	0.08(2.0)
1/4	1/4	-BR-FL4-FT4	2.20(55.9)	0.60(15.2)	0.56(14.3)	0.63(15.9)	0.63(15.9)	0.17(4.3)
3/8	3/8	-BR-FL6-FT6	2.41(61.2)	0.66(16.8)	0.69(17.5)	0.75(19.1)	0.75(19.1)	0.27(6.9)
1/2	1/2	-BR-FL8-FT8	2.87(72.9)	0.90(22.9)	0.87(22.2)	0.94(23.8)	0.94(23.8)	0.37(9.4)
5/8	5/8	-BR-FL10-FT10	2.96(75.2)	0.96(24.4)	1.00(25.4)	1.06(27.0)	1.06(27.0)	0.47(11.9)
3/4	3/4	-BR-FL12-FT12	3.21(81.5)	0.96(24.4)	1.13(28.6)	1.19(30.2)	1.19(30.2)	0.58(14.7)
1	1	-BR-FL16-FT16	3.95(100.3)	1.23(31.2)	1.50(38.1)	1.63(41.3)	1.63(41.3)	0.80(20.3)

Reducer Elbows

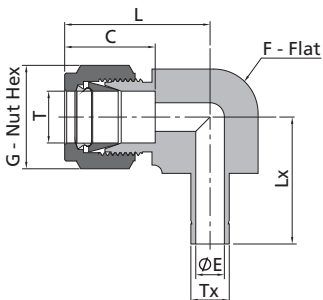

Metric Tube			Dimensions, mm (in.)					
T-Tube O.D. (mm)	Tx-Tube O.D. (mm)	Basic Ordering Number	L	C	G	F	E	Lx
			6	6	-LR-ML6-MT6	27.0(1.06)	15.3(0.60)	14.0(0.55)
12	12	-LR-ML12-MT12	38.1(1.50)	22.8(0.90)	22.0(0.87)	23.8(0.94)	8.8(0.35)	39.2(1.54)

Insert for Soft Plastic Tubings

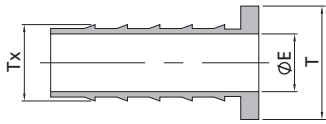

Fractional Tube			
T-Tube O.D. (in.)	Tx-Tube I.D. (in.)	Basic Ordering Number	E in. (mm)
3/16	1/8	-IN-3-2	0.09(2.3)
1/4	1/8	-IN-4-2	0.09(2.3)
1/4	0.17	-IN-4-017	0.11(2.8)
1/4	3/16	-IN-4-3	0.14(3.5)
5/16	1/8	-IN-5-2	0.09(2.3)
5/16	3/16	-IN-5-3	0.12(3.0)
5/16	1/4	-IN-5-4	0.19(4.8)
3/8	3/16	-IN-6-3	0.12(3.0)
3/8	1/4	-IN-6-4	0.19(4.8)
1/2	1/4	-IN-8-4	0.19(4.8)
1/2	3/8	-IN-8-6	0.31(7.9)
5/8	3/8	-IN-10-6	0.31(7.9)
5/8	1/2	-IN-10-8	0.44(11.1)
3/4	1/2	-IN-12-8	0.44(11.1)
3/4	5/8	-IN-12-10	0.56(14.2)
1	3/4	-IN-16-12	0.69(17.5)

Metric Tube			
T-Tube O.D. (mm)	Tx-Tube I.D. (mm)	Basic Ordering Number	E mm (in.)
6	4	-IN-6M-4M	2.8(0.11)
8	6	-IN-8M-6M	4.4(0.17)
10	8	-IN-10M-8M	6.4(0.25)
12	8	-IN-12M-8M	6.4(0.25)
12	10	-IN-12M-10M	8.3(0.33)

Port Connectors

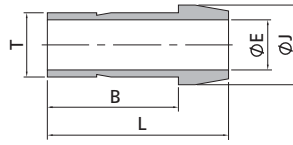

1" /25 mm and below

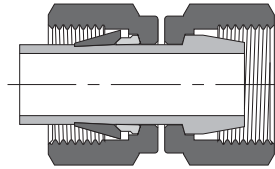

1 1/4" /28 mm and above

Fractional Tube					
T-Tube O.D. (in.)	Basic Ordering Number	Dimensions, in. (mm)			
		L	B	E	J
1/16	-P-FL1	0.54(13.7)	0.42(10.7)	0.03(0.8)	0.13(3.3)
1/8	-P-FL2	0.88(22.4)	0.62(15.7)	0.08(2.0)	0.24(6.1)
1/4	-P-FL4	0.97(24.6)	0.74(18.8)	0.17(4.3)	0.37(9.4)
5/16	-P-FL5	1.02(25.9)	0.79(20.1)	0.22(5.6)	0.43(10.9)
3/8	-P-FL6	1.03(26.2)	0.80(20.3)	0.27(6.9)	0.50(12.7)
1/2	-P-FL8	1.41(35.8)	1.02(25.9)	0.37(9.4)	0.62(15.7)
5/8	-P-FL10	1.64(41.7)	1.11(28.1)	0.47(11.9)	0.81(20.5)
3/4	-P-FL12	1.65(41.9)	1.09(27.7)	0.58(14.7)	0.87(22.1)
1	-P-FL16	1.89(48.0)	1.36(34.5)	0.80(20.3)	1.12(28.4)
1 1/4	-P-FL20	2.72(69.1)	1.99(50.6)	1.02(25.9)	1.47(37.4)
1 1/2	-P-FL24	3.31(84.1)	2.34(59.4)	1.25(31.8)	1.80(45.8)

Metric Tube					
T-Tube O.D. (mm)	Basic Ordering Number	Dimensions, mm (in.)			
		L	B	E	J
3	-P-ML3	22.2(0.87)	15.7(0.62)	1.9(0.07)	6.0(0.24)
6	-P-ML6	24.6(0.97)	18.7(0.74)	4.1(0.16)	9.0(0.35)
8	-P-ML8	25.9(1.02)	20.0(0.79)	5.6(0.22)	11.0(0.43)
10	-P-ML10	26.1(1.03)	20.2(0.80)	7.1(0.28)	13.1(0.52)
12	-P-ML12	35.8(1.41)	26.0(1.02)	8.8(0.35)	15.0(0.59)
15	-P-ML15	37.8(1.49)	27.6(1.09)	11.2(0.44)	19.6(0.77)
16	-P-ML16	37.8(1.49)	27.6(1.09)	12.0(0.47)	20.6(0.81)
18	-P-ML18	37.8(1.49)	27.7(1.09)	13.9(0.55)	21.0(0.83)
20	-P-ML20	39.4(1.55)	29.2(1.15)	15.5(0.61)	24.6(0.97)
25	-P-ML25	49.3(1.94)	34.5(1.36)	19.9(0.78)	31.2(1.23)
28	-P-ML28	63.5(2.5)	48.3(1.90)	22.5(0.89)	34.4(1.35)
30	-P-ML30	67.6(2.66)	52.2(2.06)	24.3(0.96)	37.4(1.47)
32	-P-ML32	69.7(2.74)	52.4(2.06)	26.5(1.04)	39.4(1.55)
38	-P-ML38	81.9(3.22)	61.4(2.42)	31.6(1.24)	45.8(1.80)

Reducing Port Connectors

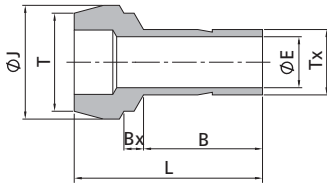

Fractional Tube								
T-Tube O.D. (in.)	Tx-Tube O.D. (in.)	Basic Ordering Number	Dimensions, in. (mm)					
			L	B	E	Bx	J	
1/8	1/16	-P-FL2-FL1	0.68(17.3)	0.34(8.6)	0.03(0.8)	0.08(2.0)	0.24(6.1)	
1/4	1/16	-P-FL4-FL1	0.71(18.0)	0.34(8.6)	0.03(0.8)	0.14(3.6)	0.37(9.4)	
1/4	1/8	-P-FL4-FL2	0.89(22.6)	0.53(13.5)	0.08(2.0)	0.13(3.3)	0.37(9.4)	
3/8	1/8	-P-FL6-FL2	0.91(23.1)	0.53(13.5)	0.08(2.0)	0.15(3.8)	0.50(12.7)	
3/8	1/4	-P-FL6-FL4	0.98(24.9)	0.62(15.7)	0.17(4.3)	0.13(3.3)	0.50(12.7)	
1/2	1/4	-P-FL8-FL4	1.15(29.2)	0.62(15.7)	0.17(4.3)	0.15(3.8)	0.62(15.7)	
1/2	3/8	-P-FL8-FL6	1.20(30.5)	0.69(17.5)	0.27(6.9)	0.13(3.3)	0.62(15.7)	
3/4	1/2	-P-FL12-FL8	1.49(37.8)	0.91(23.1)	0.37(9.4)	0.15(3.8)	0.87(22.1)	
1	1/2	-P-FL16-FL8	1.69(42.9)	0.96(24.4)	0.37(9.4)	0.19(4.8)	1.12(28.5)	
1	3/4	-P-FL16-FL12	1.72(43.7)	1.02(25.9)	0.58(14.7)	0.16(4.1)	1.12(28.5)	

Metric Tube								
T-Tube O.D. (mm)	Tx-Tube O.D. (mm)	Basic Ordering Number	Dimensions, mm (in.)					
			L	B	E	Bx	J	
6	3	-P-ML6-ML3	22.6(0.89)	13.5(0.53)	1.9(0.07)	3.2(0.13)	9.0(0.35)	
8	6	-P-ML8-ML6	24.7(0.97)	15.7(0.62)	4.1(0.16)	3.1(0.12)	11.0(0.43)	
10	6	-P-ML10-ML6	25.0(0.98)	15.7(0.62)	4.1(0.16)	3.4(0.13)	13.1(0.52)	
10	8	-P-ML10-ML8	26.3(1.04)	17.0(0.67)	5.6(0.22)	3.1(0.12)	13.1(0.52)	
12	6	-P-ML12-ML6	29.6(1.17)	15.7(0.62)	4.1(0.16)	3.6(0.14)	15.0(0.59)	
12	8	-P-ML12-ML8	29.8(1.17)	16.8(0.66)	5.6(0.22)	3.4(0.13)	15.0(0.59)	
12	10	-P-ML12-ML10	30.4(1.20)	17.5(0.69)	7.1(0.28)	3.1(0.12)	15.0(0.59)	
16	12	-P-ML16-ML12	36.2(1.43)	23.1(0.91)	8.8(0.35)	3.4(0.13)	19.0(0.75)	
28	25	-P-ML28-ML25	56.5(2.22)	33.0(1.30)	19.8(0.78)	8.2(0.32)	34.3(1.35)	
32	25	-P-ML32-ML25	60.3(2.37)	33.0(1.30)	19.8(0.78)	9.9(0.39)	39.5(1.56)	
38	25	-P-ML38-ML25	65.8(2.59)	33.0(1.30)	19.8(0.78)	12.3(0.48)	47.1(1.85)	

Sanitary Flange Fittings

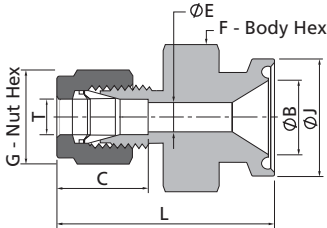

Fractional Tube									
T-Tube O.D. (in.)	Flange Size (in.)	Basic Ordering Number	Dimensions, in. (mm)						
			L	B	C	E	F	J	G
1/4	1/2	-SFF-FL4-SC8	1.57(39.9)	0.37(9.4)	0.60(15.2)	0.19(4.8)	1.00(25.4)	0.98(24.9)	0.56(14.3)
1/4	3/4	-SFF-FL4-SC12	1.57(39.9)	0.62(15.7)	0.60(15.2)	0.19(4.8)	1.00(25.4)	0.98(24.9)	0.56(14.3)
1/4	1	-SFF-FL4-SC16	1.57(39.9)	0.87(22.1)	0.60(15.2)	0.19(4.8)	1.37(34.9)	1.98(50.3)	0.56(14.3)
1/4	1 1/2	-SFF-FL4-SC24	1.57(39.9)	1.37(34.8)	0.60(15.2)	0.19(4.8)	1.37(34.9)	1.98(50.3)	0.56(14.3)
3/8	1/2	-SFF-FL6-SC8	1.63(41.4)	0.37(9.4)	0.66(16.8)	0.28(7.1)	1.00(25.4)	0.98(24.9)	0.69(17.5)
3/8	3/4	-SFF-FL6-SC12	1.63(41.4)	0.62(15.7)	0.66(16.8)	0.28(7.1)	1.00(25.4)	0.98(24.9)	0.69(17.5)
3/8	1	-SFF-FL6-SC16	1.63(41.4)	0.87(22.1)	0.66(16.8)	0.28(7.1)	1.37(34.9)	1.98(50.3)	0.69(17.5)
3/8	1 1/2	-SFF-FL6-SC24	1.63(41.4)	1.37(34.8)	0.66(16.8)	0.28(7.1)	1.37(34.9)	1.98(50.3)	0.69(17.5)
1/2	1/2	-SFF-FL8-SC8	1.74(44.2)	0.37(9.4)	0.90(22.9)	0.37(9.4)	1.00(25.4)	0.98(24.9)	0.87(22.2)
1/2	3/4	-SFF-FL8-SC12	1.74(44.2)	0.62(15.7)	0.90(22.9)	0.41(10.4)	1.00(25.4)	0.98(24.9)	0.87(22.2)
1/2	1	-SFF-FL8-SC16	1.74(44.2)	0.87(22.1)	0.90(22.9)	0.41(10.4)	1.37(34.9)	1.98(50.3)	0.87(22.2)
1/2	1 1/2	-SFF-FL8-SC24	1.74(44.2)	1.37(34.8)	0.90(22.9)	0.41(10.4)	1.37(34.9)	1.98(50.3)	0.87(22.2)
1	1	-SFF-FL16-SC16	1.91(48.5)	0.87(22.1)	1.23(31.2)	0.87(22.1)	1.37(34.9)	1.98(50.3)	1.50(38.1)
1	2	-SFF-FL16-SC32	2.49(63.2)	1.37(34.8)	1.23(31.2)	0.88(22.4)	2.75(69.9)	2.52(64.0)	1.50(38.1)

Male Adapters

Tube Fittings

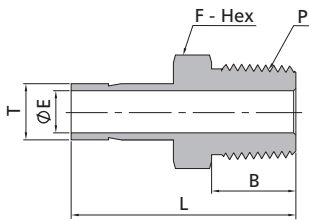

1" and below

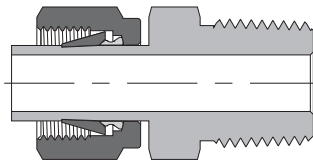

1 1/4" and above

Fractional Tube			NPT Thread			
T-Tube O.D. (in.)	P-NPT Size	Basic Ordering Number	Dimensions, in. (mm)			
			L	B	E	F
1/16	1/8	-AM-FT1-NS2	1.00(25.4)	0.38(9.7)	0.03(0.8)	0.44(11.1)
1/8	1/8	-AM-FT2-NS2	1.16(29.5)	0.38(9.7)	0.08(2.0)	0.44(11.1)
1/8	1/4	-AM-FT2-NS4	1.37(34.8)	0.56(14.2)	0.08(2.0)	0.56(14.3)
3/16	1/8	-AM-FT3-NS2	1.19(30.2)	0.38(9.7)	0.12(3.0)	0.44(11.1)
3/16	1/4	-AM-FT3-NS4	1.40(35.6)	0.56(14.2)	0.12(3.0)	0.56(14.3)
1/4	1/8	-AM-FT4-NS2	1.25(31.8)	0.38(9.7)	0.17(4.3)	0.44(11.1)
1/4	1/4	-AM-FT4-NS4	1.46(37.1)	0.56(14.2)	0.17(4.3)	0.56(14.3)
1/4	3/8	-AM-FT4-NS6	1.49(37.8)	0.56(14.2)	0.17(4.3)	0.69(17.5)
1/4	1/2	-AM-FT4-NS8	1.71(43.4)	0.75(19.1)	0.17(4.3)	0.87(22.2)
5/16	1/8	-AM-FT5-NS2	1.29(32.8)	0.38(9.7)	0.19(4.8)	0.44(11.1)
5/16	1/4	-AM-FT5-NS4	1.50(38.1)	0.56(14.2)	0.22(5.6)	0.56(14.3)
5/16	3/8	-AM-FT5-NS6	1.53(38.9)	0.56(14.2)	0.22(5.6)	0.69(17.5)
5/16	1/2	-AM-FT5-NS8	1.74(44.2)	0.75(19.1)	0.22(5.6)	0.87(22.2)
3/8	1/8	-AM-FT6-NS2	1.32(33.5)	0.38(9.7)	0.19(4.8)	0.44(11.1)
3/8	1/4	-AM-FT6-NS4	1.53(38.9)	0.56(14.2)	0.27(6.9)	0.56(14.3)
3/8	3/8	-AM-FT6-NS6	1.56(39.6)	0.56(14.2)	0.27(6.9)	0.69(17.5)
3/8	1/2	-AM-FT6-NS8	1.78(45.2)	0.75(19.1)	0.27(6.9)	0.87(22.2)
1/2	1/4	-AM-FT8-NS4	1.75(44.5)	0.56(14.2)	0.28(7.1)	0.56(14.3)
1/2	3/8	-AM-FT8-NS6	1.78(45.2)	0.56(14.2)	0.37(9.4)	0.69(17.5)
1/2	1/2	-AM-FT8-NS8	2.00(50.8)	0.75(19.1)	0.37(9.4)	0.87(22.2)
5/8	1/2	-AM-FT10-NS8	2.06(52.3)	0.75(19.1)	0.47(11.9)	0.87(22.2)
3/4	1/2	-AM-FT12-NS8	2.06(52.3)	0.75(19.1)	0.47(11.9)	0.87(22.2)
3/4	3/4	-AM-FT12-NS12	2.06(52.3)	0.75(19.1)	0.58(14.7)	1.06(27.0)
3/4	1	-AM-FT12-NS16	2.41(61.2)	0.94(23.9)	0.58(14.7)	1.37(34.9)
1	3/4	-AM-FT16-NS12	2.31(58.7)	0.75(19.1)	0.62(15.7)	1.06(27.0)
1	1	-AM-FT16-NS16	2.60(66.0)	0.94(23.9)	0.80(20.3)	1.37(34.9)
1 1/4	1 1/4	-AM-FT20-NS20	3.16(80.3)	0.94(23.9)	1.02(25.9)	1.75(44.5)
1 1/2	1 1/2	-AM-FT24-NS24	3.72(94.5)	1.03(26.2)	1.25(31.8)	2.13(54.0)

Fractional Tube			ISO Tapered Thread (RT)			
T-Tube O.D. (in.)	P-RT Size	Basic Ordering Number	Dimensions, in. (mm)			
			L	B	E	F
1/8	1/8	-AM-FT2-RT2	1.16(29.5)	0.38(9.7)	0.08(2.0)	0.44(11.1)
1/8	1/4	-AM-FT2-RT4	1.37(34.8)	0.56(14.2)	0.08(2.0)	0.56(14.3)
1/4	1/8	-AM-FT4-RT2	1.25(31.8)	0.38(9.7)	0.17(4.3)	0.44(11.1)
1/4	1/4	-AM-FT4-RT4	1.46(37.1)	0.56(14.2)	0.17(4.3)	0.56(14.3)
1/4	3/8	-AM-FT4-RT6	1.49(37.8)	0.56(14.2)	0.17(4.3)	0.69(17.5)
1/4	1/2	-AM-FT4-RT8	1.71(43.4)	0.75(19.1)	0.17(4.3)	0.87(22.2)
5/16	1/8	-AM-FT5-RT2	1.29(32.8)	0.38(9.7)	0.19(4.8)	0.44(11.1)
5/16	1/4	-AM-FT5-RT4	1.50(38.1)	0.56(14.2)	0.22(5.6)	0.56(14.3)
3/8	1/4	-AM-FT6-RT4	1.53(38.9)	0.56(14.2)	0.27(6.9)	0.56(14.3)
3/8	3/8	-AM-FT6-RT6	1.56(39.6)	0.56(14.2)	0.27(6.9)	0.69(17.5)
3/8	1/2	-AM-FT6-RT8	1.78(45.2)	0.75(19.1)	0.27(6.9)	0.87(22.2)
1/2	1/4	-AM-FT8-RT4	1.75(44.5)	0.56(14.2)	0.28(7.1)	0.56(14.3)
1/2	3/8	-AM-FT8-RT6	1.78(45.2)	0.56(14.2)	0.37(9.4)	0.69(17.5)
1/2	1/2	-AM-FT8-RT8	2.00(50.8)	0.75(19.1)	0.37(9.4)	0.87(22.2)
5/8	3/8	-AM-FT10-RT6	1.91(48.5)	0.56(14.2)	0.37(9.5)	0.69(17.5)
5/8	1/2	-AM-FT10-RT8	2.06(52.3)	0.75(19.1)	0.47(11.9)	0.87(22.2)
3/4	3/4	-AM-FT12-RT12	2.06(52.3)	0.75(19.1)	0.58(14.7)	1.06(27.0)
1	1	-AM-FT16-RT16	2.60(66.0)	0.94(23.9)	0.80(20.3)	1.37(34.9)

Male Adapters

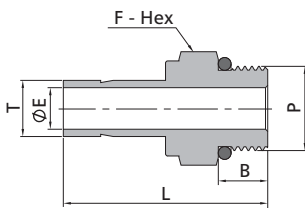
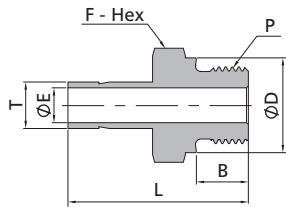
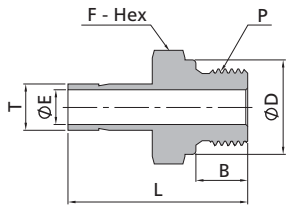

1" and below

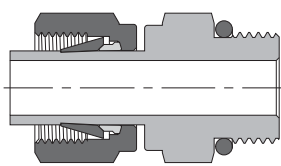

1 1/4" and above

Adapt to straight thread boss of SAE J1926-1, ISO 11926-1 and MS 16142.

Fractional Tube			ISO Parallel Thread (RS)				
T-Tube O.D. (in.)	P-RS Size	Basic Ordering Number	Dimensions, in. (mm)				
			L	B	E	F	D
1/8	1/8	-AM-FT2-RS2	1.22(31.0)	0.28(7.1)	0.08(2.0)	0.56(14.3)	0.54(13.7)
1/8	1/4	-AM-FT2-RS4	1.41(35.8)	0.44(11.2)	0.08(2.0)	0.75(19.1)	0.70(17.8)
1/4	1/8	-AM-FT4-RS2	1.31(33.3)	0.28(7.1)	0.16(4.1)	0.56(14.3)	0.54(13.7)
1/4	1/4	-AM-FT4-RS4	1.50(38.1)	0.44(11.2)	0.17(4.3)	0.75(19.1)	0.70(17.8)
3/8	1/8	-AM-FT6-RS2	1.29(32.8)	0.28(7.1)	0.16(4.1)	0.56(14.3)	0.54(13.7)
3/8	1/4	-AM-FT6-RS4	1.57(39.9)	0.44(11.2)	0.23(5.8)	0.75(19.1)	0.70(17.8)
3/8	3/8	-AM-FT6-RS6	1.60(40.6)	0.44(11.2)	0.27(6.9)	0.87(22.2)	0.85(21.6)
3/8	1/2	-AM-FT6-RS8	1.69(42.9)	0.56(14.2)	0.28(7.1)	1.06(27.0)	1.02(25.9)
1/2	1/4	-AM-FT8-RS4	1.79(45.5)	0.44(11.2)	0.23(5.8)	0.75(19.1)	0.70(17.8)
1/2	3/8	-AM-FT8-RS6	1.82(46.2)	0.44(11.2)	0.31(7.9)	0.87(22.2)	0.85(21.6)
1/2	1/2	-AM-FT8-RS8	1.94(49.2)	0.56(14.2)	0.37(9.4)	1.06(27.0)	1.02(25.9)
5/8	1/2	-AM-FT10-RS8	1.97(50.0)	0.56(14.2)	0.47(11.9)	1.06(27.0)	1.02(25.9)
3/4	3/4	-AM-FT12-RS12	2.16(54.9)	0.63(16.0)	0.58(14.7)	1.31(33.3)	1.26(32.0)
1	1	-AM-FT16-RS16	2.54(64.5)	0.72(18.3)	0.80(20.3)	1.63(41.3)	1.53(38.9)

Fractional Tube			ISO Parallel Thread (RP)				
T-Tube O.D. (in.)	P-RP Size	Basic Ordering Number	Dimensions, in. (mm)				
			L	B	E	F	D
1/8	1/8	-AM-FT2-RP2	1.09(27.7)	0.28(7.1)	0.08(2.0)	0.56(14.3)	0.54(13.7)
1/8	1/4	-AM-FT2-RP4	1.31(33.3)	0.44(11.2)	0.08(2.0)	0.75(19.1)	0.70(17.8)
1/4	1/8	-AM-FT4-RP2	1.19(30.2)	0.28(7.1)	0.16(4.1)	0.56(14.3)	0.54(13.7)
1/4	1/4	-AM-FT4-RP4	1.50(38.1)	0.44(11.2)	0.18(4.6)	0.75(19.1)	0.70(17.8)
3/8	1/8	-AM-FT6-RP2	1.34(34.0)	0.28(7.1)	0.16(4.1)	0.75(19.1)	0.54(13.7)
3/8	1/4	-AM-FT6-RP4	1.47(37.3)	0.44(11.2)	0.25(6.4)	0.75(19.1)	0.70(17.8)
3/8	3/8	-AM-FT6-RP6	1.50(38.1)	0.44(11.2)	0.27(6.9)	0.87(22.2)	0.85(21.6)
3/8	1/2	-AM-FT6-RP8	1.69(42.9)	0.56(14.2)	0.27(6.9)	1.06(27.0)	1.02(25.9)
1/2	1/4	-AM-FT8-RP4	1.69(42.9)	0.44(11.2)	0.25(6.4)	0.75(19.1)	0.70(17.8)
1/2	3/8	-AM-FT8-RP6	1.72(43.7)	0.44(11.2)	0.31(7.9)	0.87(22.2)	0.85(21.6)
1/2	1/2	-AM-FT8-RP8	1.94(49.3)	0.56(14.2)	0.37(9.4)	1.06(27.0)	1.02(25.9)
5/8	1/2	-AM-FT10-RP8	1.97(50.0)	0.56(14.2)	0.47(11.9)	1.06(27.0)	1.02(25.9)
3/4	3/4	-AM-FT12-RP12	2.09(53.1)	0.63(16.0)	0.58(14.7)	1.32(33.5)	1.26(32.0)
1	1	-AM-FT16-RP16	2.49(63.3)	0.72(18.3)	0.78(19.8)	1.63(41.3)	1.53(38.9)

Fractional Tube			SAE/MS Straight Thread			
T-Tube O.D. (in.)	P-SAE/MS Thread Size	Basic Ordering Number	Dimensions, in. (mm)			
			L	B	E	F
1/8	5/16-24	-AM-FT2-ST5	1.20(30.5)	0.30(7.6)	0.08(2.0)	0.44(11.1)
1/4	7/16-20	-AM-FT4-ST7	1.39(35.3)	0.36(9.1)	0.17(4.3)	0.56(14.3)
3/8	7/16-20	-AM-FT6-ST7	1.46(37.1)	0.36(9.1)	0.20(5.1)	0.56(14.3)
3/8	9/16-18	-AM-FT6-ST9	1.52(38.6)	0.39(9.9)	0.27(6.9)	0.69(17.5)
3/8	3/4-16	-AM-FT6-ST12	1.60(40.6)	0.44(11.2)	0.27(6.9)	0.87(22.2)
1/2	9/16-18	-AM-FT8-ST9	1.74(44.2)	0.39(9.9)	0.28(7.1)	0.69(17.5)
1/2	3/4-16	-AM-FT8-ST12	1.82(46.2)	0.44(11.2)	0.37(9.4)	0.87(22.2)
5/8	7/8-14	-AM-FT10-ST14	1.94(49.3)	0.50(12.7)	0.47(11.9)	1.00(25.4)
3/4	1 1/16-12	-AM-FT12-ST17	2.10(53.3)	0.59(15.0)	0.58(14.7)	1.25(31.8)
1	1 5/16-12	-AM-FT16-ST21	2.41(61.2)	0.59(15.0)	0.80(20.3)	1.50(38.1)
1 1/4	1 5/8-12	-AM-FT20-ST26	2.81(71.4)	0.59(15.0)	1.02(25.9)	1.87(47.6)
1 1/2	1 7/8-12	-AM-FT24-ST30	3.28(83.3)	0.59(15.0)	1.25(31.8)	2.13(54.0)

A-70 6 Series Tube Fittings

Male Adapters

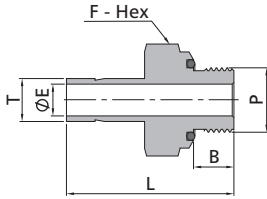
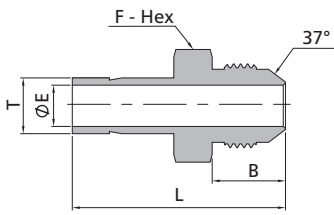

Fractional Tube			37° Flare (AN)			
T-Tube O.D. (in.)	AN Tube Flare Size	Basic Ordering Number	Dimensions, in. (mm)			
			L	B	E	F
1/4	1/4	-AM-FT4-AN4	1.46(37.1)	0.55(14.0)	0.17(4.3)	0.50(12.7)
3/8	1/4	-AM-FT6-AN4	1.53(38.9)	0.55(14.0)	0.17(4.3)	0.50(12.7)
3/8	3/8	-AM-FT6-AN6	1.56(39.6)	0.56(14.2)	0.27(6.9)	0.63(15.9)
1/2	1/2	-AM-FT8-AN8	1.91(48.5)	0.66(16.8)	0.37(9.4)	0.81(20.6)
3/4	3/4	-AM-FT12-AN12	2.21(56.1)	0.86(21.8)	0.58(14.7)	1.13(28.6)
1	1	-AM-FT16-AN16	2.58(65.5)	0.91(23.1)	0.80(20.3)	1.37(34.9)

Fractional Tube			O-Seal with SAE/MS Straight Thread			
T-Tube O.D. (in.)	P-SAE/MS Thread Size	Basic Ordering Number	Dimensions, in. (mm)			
			L	B	E	F
1/8	5/16-24	-AM-FT2-OST5	1.28(32.5)	0.34(8.6)	0.08(2.0)	0.56(14.3)
3/16	3/8-24	-AM-FT3-OST6	1.38(35.1)	0.38(9.7)	0.12(3.0)	0.63(15.9)
1/4	7/16-20	-AM-FT4-OST7	1.54(39.1)	0.41(10.4)	0.17(4.3)	0.75(19.1)
5/16	1/2-20	-AM-FT5-OST8	1.64(41.7)	0.44(11.2)	0.22(5.6)	0.87(22.2)
3/8	9/16-18	-AM-FT6-OST9	1.70(43.2)	0.47(11.9)	0.27(6.9)	0.94(23.8)
1/2	3/4-16	-AM-FT8-OST12	1.95(49.5)	0.47(11.9)	0.37(9.4)	1.13(28.6)

Male Adapters

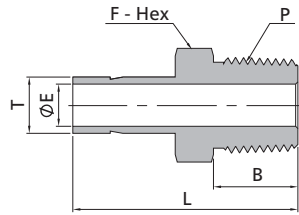

25 mm and below

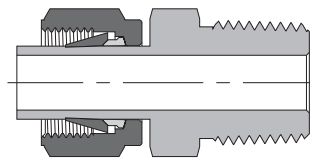

28 mm and above

Metric Tube			NPT Thread			
T-Tube O.D. (mm)	P-NPT Size	Basic Ordering Number	Dimensions, mm (in.)			
			L	B	E	F
3	1/8	-AM-MT3-NS2	29.4(1.16)	9.7(0.38)	1.8(0.07)	12.0(0.47)
4	1/8	-AM-MT4-NS2	29.4(1.16)	9.7(0.38)	2.4(0.09)	12.0(0.47)
6	1/8	-AM-MT6-NS2	32.8(1.29)	9.7(0.38)	4.1(0.16)	12.0(0.47)
6	1/4	-AM-MT6-NS4	38.1(1.50)	14.2(0.56)	4.1(0.16)	14.0(0.55)
6	3/8	-AM-MT6-NS6	39.2(1.54)	14.2(0.56)	4.1(0.16)	18.0(0.71)
6	1/2	-AM-MT6-NS8	42.1(1.66)	19.1(0.75)	4.1(0.16)	22.0(0.87)
8	1/4	-AM-MT8-NS4	39.1(1.54)	14.2(0.56)	5.6(0.22)	14.0(0.55)
8	3/8	-AM-MT8-NS6	39.9(1.57)	14.2(0.56)	5.6(0.22)	19.0(0.75)
10	1/4	-AM-MT10-NS4	39.9(1.57)	14.2(0.56)	7.1(0.28)	14.0(0.55)
10	3/8	-AM-MT10-NS6	40.6(1.60)	14.2(0.56)	7.1(0.28)	18.0(0.71)
10	1/2	-AM-MT10-NS8	46.2(1.82)	19.1(0.75)	7.1(0.28)	22.0(0.87)
12	1/4	-AM-MT12-NS4	46.5(1.83)	14.2(0.56)	7.1(0.28)	14.0(0.55)
12	3/8	-AM-MT12-NS6	46.2(1.82)	14.2(0.56)	8.8(0.35)	18.0(0.71)
12	1/2	-AM-MT12-NS8	52.1(2.05)	19.1(0.75)	8.8(0.35)	22.0(0.87)
16	1/2	-AM-MT16-NS8	50.8(2.00)	19.1(0.75)	11.9(0.47)	22.0(0.87)
16	3/4	-AM-MT16-NS12	51.6(2.03)	19.1(0.75)	12.0(0.47)	27.0(1.06)
18	1/2	-AM-MT18-NS8	50.8(2.00)	19.1(0.75)	11.9(0.47)	27.0(1.06)
18	3/4	-AM-MT18-NS12	51.6(2.03)	19.1(0.75)	14.0(0.55)	27.0(1.06)
20	1/2	-AM-MT20-NS8	53.3(2.1)	19.1(0.75)	11.9(0.47)	22.0(0.87)
20	3/4	-AM-MT20-NS12	53.8(2.12)	19.1(0.75)	15.5(0.61)	27.0(1.06)
25	1	-AM-MT25-NS16	65.9(2.59)	23.9(0.94)	19.8(0.78)	35.0(1.38)
28	1	-AM-MT28-NS16	74.7(2.94)	23.9(0.94)	22.2(0.87)	35.0(1.38)
28	1 1/4	-AM-MT28-NS20	76.2(3.00)	23.9(0.94)	22.5(0.89)	46.0(1.81)
30	1	-AM-MT30-NS16	79.2(3.12)	23.9(0.94)	22.2(0.87)	41.0(1.61)
30	1 1/4	-AM-MT30-NS20	80.0(3.15)	23.9(0.94)	24.3(0.96)	46.0(1.81)
32	1 1/4	-AM-MT32-NS20	81.0(3.19)	23.9(0.94)	26.5(1.04)	46.0(1.81)
38	1 1/2	-AM-MT38-NS24	92.2(3.63)	26.2(1.03)	31.6(1.24)	55.0(2.17)

Metric Tube			ISO Tapered Thread (RT)			
T-Tube O.D. (mm)	P-RT Size	Basic Ordering Number	Dimensions, mm (in.)			
			L	B	E	F
3	1/8	-AM-MT3-RT2	29.4(1.16)	9.7(0.38)	2.4(0.09)	12.0(0.47)
4	1/8	-AM-MT4-RT2	29.4(1.16)	9.7(0.38)	2.0(0.08)	12.0(0.47)
6	1/8	-AM-MT6-RT2	32.8(1.29)	9.7(0.38)	4.1(0.16)	12.0(0.47)
6	1/4	-AM-MT6-RT4	38.1(1.50)	14.2(0.56)	4.1(0.16)	14.0(0.55)
8	1/4	-AM-MT8-RT4	39.1(1.54)	14.2(0.56)	5.6(0.22)	14.0(0.55)
8	3/8	-AM-MT8-RT6	39.9(1.57)	14.2(0.56)	5.6(0.22)	18.0(0.71)
10	1/4	-AM-MT10-RT4	39.9(1.57)	14.2(0.56)	7.1(0.28)	14.0(0.55)
10	3/8	-AM-MT10-RT6	40.6(1.60)	14.2(0.56)	7.1(0.28)	18.0(0.71)
10	1/2	-AM-MT10-RT8	44.5(1.75)	19.1(0.75)	7.1(0.28)	22.0(0.87)
12	1/4	-AM-MT12-RT4	46.5(1.83)	14.2(0.56)	7.1(0.28)	16.0(0.63)
12	3/8	-AM-MT12-RT6	46.2(1.82)	14.2(0.56)	8.8(0.35)	18.0(0.71)
12	1/2	-AM-MT12-RT8	51.8(2.04)	19.1(0.75)	8.8(0.35)	22.0(0.87)
16	1/2	-AM-MT16-RT8	50.8(2.00)	19.1(0.75)	11.9(0.47)	22.0(0.87)
18	3/4	-AM-MT18-RT12	51.6(2.03)	19.1(0.75)	14.0(0.55)	27.0(1.06)
20	3/4	-AM-MT20-RT12	52.4(2.06)	19.1(0.75)	15.5(0.61)	27.0(1.06)
25	1	-AM-MT25-RT16	65.9(2.59)	23.9(0.94)	19.8(0.78)	35.0(1.38)
28	1	-AM-MT28-RT16	74.7(2.94)	23.9(0.94)	22.2(0.87)	35.0(1.38)
28	1 1/4	-AM-MT28-RT20	76.2(3.00)	23.9(0.94)	22.5(0.89)	46.0(1.81)
30	1 1/4	-AM-MT30-RT20	80.0(3.15)	23.9(0.94)	24.3(0.96)	46.0(1.81)
32	1 1/4	-AM-MT32-RT20	81.0(3.19)	23.9(0.94)	26.5(1.04)	46.0(1.81)
38	1 1/2	-AM-MT38-RT24	92.2(3.63)	26.2(1.03)	31.6(1.24)	55.0(2.17)

Male Adapters

Tube Fittings

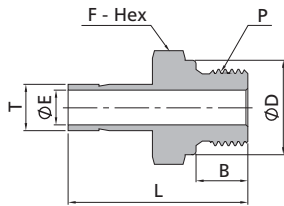

25 mm and below

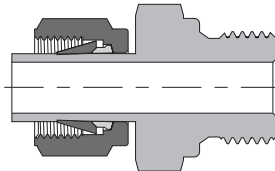

28 mm and above

Metric Tube			ISO Parallel Thread (RS)				
T-Tube O.D. (mm)	P-RS Size	Basic Ordering Number	Dimensions, mm (in.)				
			L	B	E	F	D
3	1/8	-AM-MT3-RS2	31.0(1.22)	7.1(0.28)	1.8(0.07)	14.0(0.55)	13.7(0.54)
4	1/8	-AM-MT4-RS2	31.8(1.25)	7.1(0.28)	2.4(0.09)	14.0(0.55)	13.7(0.54)
6	1/8	-AM-MT6-RS2	34.3(1.35)	7.1(0.28)	4.0(0.16)	14.0(0.55)	13.7(0.54)
6	1/4	-AM-MT6-RS4	39.1(1.54)	11.2(0.44)	4.1(0.16)	19.0(0.75)	17.8(0.70)
8	1/4	-AM-MT8-RS4	39.6(1.56)	11.2(0.44)	5.6(0.22)	19.0(0.75)	17.8(0.70)
10	1/4	-AM-MT10-RS4	40.9(1.61)	11.2(0.44)	5.9(0.23)	19.0(0.75)	17.8(0.70)
10	3/8	-AM-MT10-RS6	41.7(1.64)	11.2(0.44)	7.1(0.28)	22.0(0.87)	21.6(0.85)
10	1/2	-AM-MT10-RS8	44.7(1.76)	14.2(0.56)	7.1(0.28)	27.0(1.06)	25.9(1.02)
12	1/4	-AM-MT12-RS4	46.7(1.84)	11.2(0.44)	5.9(0.23)	19.0(0.75)	17.8(0.70)
12	3/8	-AM-MT12-RS6	47.2(1.86)	11.2(0.44)	7.9(0.31)	22.0(0.87)	21.6(0.85)
12	1/2	-AM-MT12-RS8	50.5(1.99)	14.2(0.56)	8.8(0.35)	27.0(1.06)	25.9(1.02)
16	1/2	-AM-MT16-RS8	50.8(2.00)	14.2(0.56)	11.9(0.47)	27.0(1.06)	25.9(1.02)
18	3/4	-AM-MT18-RS12	55.9(2.20)	16.0(0.63)	13.9(0.55)	35.0(1.38)	32.0(1.26)
20	3/4	-AM-MT20-RS12	57.0(2.24)	16.0(0.63)	15.5(0.61)	35.0(1.38)	32.0(1.26)
25	1	-AM-MT25-RS16	65.1(2.56)	18.3(0.72)	19.8(0.78)	41.0(1.61)	38.9(1.53)
28	1	-AM-MT28-RS16	71.9(2.83)	18.3(0.72)	19.8(0.78)	41.0(1.61)	38.9(1.53)
28	1 1/4	-AM-MT28-RS20	77.0(3.03)	19.8(0.78)	22.5(0.89)	50.0(1.97)	49.0(1.93)
30	1 1/4	-AM-MT30-RS20	80.8(3.18)	19.8(0.78)	24.3(0.96)	50.0(1.97)	49.0(1.93)
32	1 1/4	-AM-MT32-RS20	81.8(3.22)	19.8(0.78)	26.5(1.04)	50.0(1.97)	49.0(1.93)
38	1 1/2	-AM-MT38-RS24	94.5(3.72)	20.6(0.81)	31.6(1.24)	55.0(2.17)	54.7(2.15)

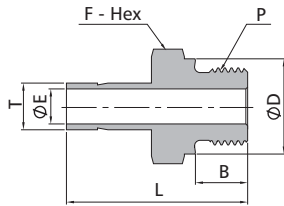

25 mm and below

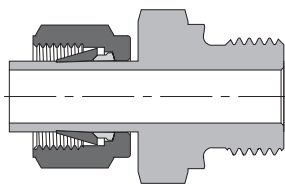

28 mm and above

Metric Tube			ISO Parallel Thread (RP)				
T-Tube O.D. (mm)	P-RP Size	Basic Ordering Number	Dimensions, mm (in.)				
			L	B	E	F	D
3	1/8	-AM-MT3-RP2	31.0(1.22)	7.1(0.28)	1.8(0.07)	14.0(0.55)	13.7(0.54)
4	1/8	-AM-MT4-RP2	31.8(1.25)	7.1(0.28)	2.0(0.08)	14.0(0.55)	13.7(0.54)
6	1/8	-AM-MT6-RP2	34.3(1.35)	7.1(0.28)	4.0(0.16)	14.0(0.55)	13.7(0.54)
6	1/4	-AM-MT6-RP4	38.1(1.50)	11.2(0.44)	4.0(0.16)	19.0(0.75)	17.8(0.70)
8	1/4	-AM-MT8-RP4	38.9(1.53)	11.2(0.44)	5.6(0.22)	19.0(0.75)	17.8(0.70)
10	1/4	-AM-MT10-RP4	38.9(1.53)	11.2(0.44)	6.4(0.25)	19.0(0.75)	17.8(0.70)
10	3/8	-AM-MT10-RP6	39.7(1.56)	11.2(0.44)	7.1(0.28)	22.0(0.87)	21.6(0.85)
10	1/2	-AM-MT10-RP8	42.9(1.69)	14.2(0.56)	7.1(0.28)	27.0(1.06)	25.9(1.02)
12	1/4	-AM-MT12-RP4	43.7(1.72)	11.2(0.44)	6.4(0.25)	19.0(0.75)	17.8(0.70)
12	3/8	-AM-MT12-RP6	44.5(1.75)	11.2(0.44)	7.9(0.31)	22.0(0.87)	21.6(0.85)
12	1/2	-AM-MT12-RP8	49.2(1.94)	14.2(0.56)	9.1(0.36)	27.0(1.06)	25.9(1.02)
16	1/2	-AM-MT16-RP8	50.8(2.00)	14.2(0.56)	11.9(0.47)	27.0(1.06)	25.9(1.02)
18	3/4	-AM-MT18-RP12	53.2(2.09)	16.0(0.63)	14.0(0.55)	33.0(1.30)	32.0(1.26)
20	3/4	-AM-MT20-RP12	54.0(2.13)	16.0(0.63)	15.5(0.61)	33.0(1.30)	32.0(1.26)
25	1	-AM-MT25-RP16	65.1(2.56)	18.3(0.72)	19.8(0.78)	41.0(1.61)	38.9(1.53)
28	1	-AM-MT28-RP16	72.7(2.86)	18.3(0.72)	19.8(0.78)	41.0(1.61)	38.9(1.53)
28	1 1/4	-AM-MT28-RP20	77.3(3.04)	19.8(0.78)	22.5(0.89)	50.0(1.97)	49.0(1.93)
30	1 1/4	-AM-MT30-RP20	80.8(3.18)	19.8(0.78)	24.3(0.96)	50.0(1.97)	49.0(1.93)
32	1 1/4	-AM-MT32-RP20	82.1(3.23)	19.8(0.78)	26.5(1.04)	50.0(1.97)	49.0(1.93)
38	1 1/2	-AM-MT38-RP24	94.5(3.72)	20.6(0.81)	31.6(1.24)	55.0(2.17)	54.7(2.15)

Female Adapters

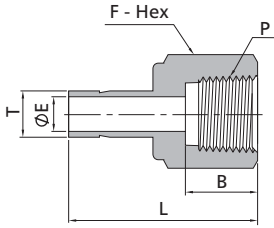

1" and below

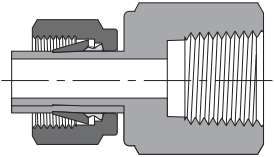

1 1/4" and above

Fractional Tube			NPT Thread			
T-Tube O.D. (in.)	P-NPT Size	Basic Ordering Number	Dimensions, in. (mm)			
			L	B	E	F
1/16	1/8	-AF-FT1-NS2	1.07(27.2)	0.41(10.4)	0.03(0.8)	0.56(14.3)
1/8	1/8	-AF-FT2-NS2	1.24(31.5)	0.41(10.4)	0.08(2.0)	0.56(14.3)
1/8	1/4	-AF-FT2-NS4	1.39(35.3)	0.59(15.0)	0.08(2.0)	0.75(19.1)
3/16	1/8	-AF-FT3-NS2	1.25(31.8)	0.41(10.4)	0.11(2.9)	0.56(14.3)
3/16	1/4	-AF-FT3-NS4	1.41(35.8)	0.59(15.0)	0.12(3.0)	0.75(19.1)
1/4	1/8	-AF-FT4-NS2	1.30(33.0)	0.41(10.4)	0.17(4.3)	0.56(14.3)
1/4	1/4	-AF-FT4-NS4	1.46(37.1)	0.59(15.0)	0.17(4.3)	0.75(19.1)
1/4	3/8	-AF-FT4-NS6	1.55(39.4)	0.59(15.0)	0.17(4.3)	0.87(22.2)
1/4	1/2	-AF-FT4-NS8	1.79(45.5)	0.78(19.8)	0.17(4.3)	1.06(27.0)
5/16	1/8	-AF-FT5-NS2	1.34(34.0)	0.41(10.4)	0.22(5.6)	0.56(14.3)
5/16	1/4	-AF-FT5-NS4	1.48(37.6)	0.59(15.0)	0.22(5.6)	0.75(19.1)
5/16	3/8	-AF-FT5-NS6	1.59(40.4)	0.59(15.0)	0.22(5.6)	0.87(22.2)
3/8	1/8	-AF-FT6-NS2	1.35(34.3)	0.41(10.4)	0.27(6.9)	0.56(14.3)
3/8	1/4	-AF-FT6-NS4	1.50(38.1)	0.59(15.0)	0.27(6.9)	0.75(19.1)
3/8	3/8	-AF-FT6-NS6	1.59(40.4)	0.59(15.0)	0.27(6.9)	0.87(22.2)
3/8	1/2	-AF-FT6-NS8	1.84(46.7)	0.78(19.8)	0.27(6.9)	1.06(27.0)
1/2	1/4	-AF-FT8-NS4	1.71(43.4)	0.59(15.0)	0.37(9.4)	0.75(19.1)
1/2	3/8	-AF-FT8-NS6	1.79(45.5)	0.59(15.0)	0.37(9.4)	0.87(22.2)
1/2	1/2	-AF-FT8-NS8	2.04(51.8)	0.78(19.8)	0.37(9.4)	1.06(27.0)
5/8	3/8	-AF-FT10-NS6	1.86(47.2)	0.59(15.0)	0.47(11.9)	0.87(22.2)
5/8	1/2	-AF-FT10-NS8	2.09(53.1)	0.78(19.8)	0.47(11.9)	1.06(27.0)
3/4	1/2	-AF-FT12-NS8	2.08(52.8)	0.78(19.8)	0.58(14.7)	1.06(27.0)
3/4	3/4	-AF-FT12-NS12	2.16(54.9)	0.81(20.6)	0.58(14.7)	1.31(33.3)
3/4	1	-AF-FT12-NS16	2.30(58.4)	1.00(25.4)	0.58(14.7)	1.63(41.3)
7/8	3/4	-AF-FT14-NS12	2.22(56.4)	0.81(20.6)	0.58(14.7)	1.31(33.3)
1	3/4	-AF-FT16-NS12	2.39(60.7)	0.81(20.6)	0.80(20.3)	1.31(33.3)
1	1	-AF-FT16-NS16	2.53(64.3)	1.00(25.4)	0.80(20.3)	1.63(41.3)
1 1/4	1 1/4	-AF-FT20-NS20	3.06(77.7)	1.00(25.4)	1.02(25.9)	2.13(54.0)
1 1/2	1 1/2	-AF-FT24-NS24	3.50(88.9)	1.09(27.7)	1.25(31.8)	2.37(60.3)

Fractional Tube			ISO Tapered Thread (RT)			
T-Tube O.D. (in.)	P-RT Size	Basic Ordering Number	Dimensions, in. (mm)			
			L	B	E	F
1/4	1/8	-AF-FT4-RT2	1.30(33.0)	0.41(10.4)	0.17(4.3)	0.56(14.3)
1/4	1/4	-AF-FT4-RT4	1.45(36.8)	0.59(15.0)	0.17(4.3)	0.75(19.1)
3/8	1/4	-AF-FT6-RT4	1.50(38.1)	0.59(15.0)	0.27(6.9)	0.75(19.1)
3/8	3/8	-AF-FT6-RT6	1.59(40.4)	0.59(15.0)	0.27(6.9)	0.87(22.2)
1/2	1/4	-AF-FT8-RT4	1.71(43.4)	0.59(15.0)	0.37(9.4)	0.75(19.1)
1/2	3/8	-AF-FT8-RT6	1.80(45.7)	0.59(15.0)	0.37(9.4)	0.87(22.2)
1/2	1/2	-AF-FT8-RT8	2.05(52.1)	0.78(19.8)	0.37(9.4)	1.06(27.0)

Tube Fittings

A-74 6 Series Tube Fittings

Female Adapters

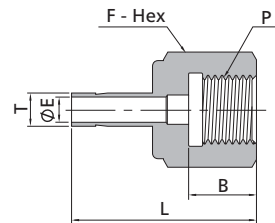
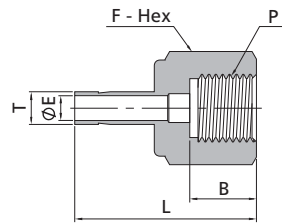
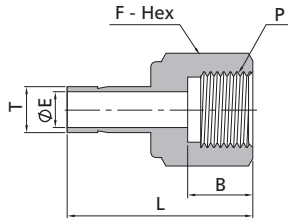

Adapt to Japanese gauge stud.

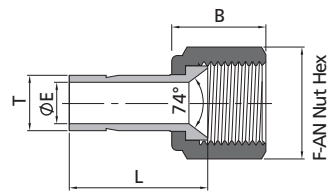

Fractional Tube			ISO Parallel Thread (RP)			
T-Tube O.D. (in.)	P-RP Size	Basic Ordering Number	Dimensions, in. (mm)			
			L	B	E	F
1/8	1/8	-AF-FT2-RP2	1.17(29.7)	0.40(10.2)	0.08(2.0)	0.56(14.3)
1/4	1/8	-AF-FT4-RP2	1.25(31.8)	0.40(10.2)	0.17(4.3)	0.56(14.3)
1/4	1/4	-AF-FT4-RP4	1.50(38.1)	0.61(15.5)	0.17(4.3)	0.75(19.1)
3/8	1/4	-AF-FT6-RP4	1.55(39.4)	0.61(15.5)	0.27(6.9)	0.75(19.1)
3/8	3/8	-AF-FT6-RP6	1.57(39.9)	0.60(15.2)	0.27(6.9)	0.94(23.8)
1/2	3/8	-AF-FT8-RP6	1.78(45.2)	0.60(15.2)	0.38(9.7)	0.94(23.8)
1/2	1/2	-AF-FT8-RP8	1.95(49.5)	0.73(18.5)	0.38(9.7)	1.06(27.0)

Fractional Tube			ISO Parallel Thread (RG)			
T-Tube O.D. (in.)	P-RG Size	Basic Ordering Number	Dimensions, in. (mm)			
			L	B	E	F
1/4	1/4	-AF-FT4-RG4	1.39(35.3)	0.51(12.9)	0.17(4.3)	0.75(19.1)
3/8	3/8	-AF-FT6-RG6	1.55(39.4)	0.56(14.2)	0.26(6.6)	0.94(23.8)
1/2	1/2	-AF-FT8-RG8	1.80(45.7)	0.74(18.8)	0.28(7.1)	1.06(27.0)

Fractional Tube			ISO Parallel Thread (RJ)			
T-Tube O.D. (in.)	P-RJ Size	Basic Ordering Number	Dimensions, in. (mm)			
			L	B	E	F
1/4	1/4	-AF-FT4-RJ4	1.39(35.3)	0.51(12.9)	0.17(4.3)	0.75(19.1)
3/8	3/8	-AF-FT6-RJ6	1.55(39.4)	0.62(15.8)	0.26(6.6)	0.94(23.8)
1/2	1/2	-AF-FT8-RJ8	1.94(49.3)	0.74(18.8)	0.28(7.1)	1.06(27.0)

Fractional Tube			AN Thread			
T-Tube O.D. (in.)	AN Tube Flare Size(in.)	Basic Ordering Number	Dimensions, in. (mm)			
			L	B	E	F
1/8	1/8	-AF-FT2-AN2	0.88(22.4)	0.55(14.0)	0.08(2.0)	0.37(9.5)
1/8	1/4	-AF-FT2-AN4	0.88(22.4)	0.62(15.8)	0.16(4.0)	0.56(14.3)
1/4	1/4	-AF-FT4-AN4	0.96(24.4)	0.62(15.8)	0.18(4.6)	0.56(14.3)
3/8	3/8	-AF-FT6-AN6	0.98(24.9)	0.73(18.5)	0.27(6.8)	0.75(19.05)
1/2	1/2	-AF-FT8-AN8	1.42(36.1)	0.85(21.6)	0.37(9.4)	0.87(22.2)
3/4	3/4	-AF-FT12-AN12	1.49(37.8)	1.03(26.2)	0.58(14.7)	1.25(31.8)

Female Adapters

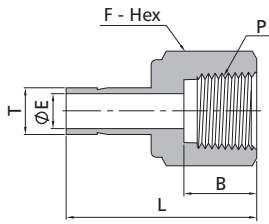

Metric Tube			NPT Thread			
T-Tube O.D. (mm)	P-NPT Size	Basic Ordering Number	Dimensions, mm (in.)			
			L	B	E	F
3	1/8	-AF-MT3-NS2	28.8(1.13)	10.4(0.41)	1.3(0.05)	14.0(0.55)
4	1/8	-AF-MT4-NS2	33.3(1.31)	10.4(0.41)	2.4(0.09)	14.0(0.55)
6	1/8	-AF-MT6-NS2	32.5(1.28)	10.4(0.41)	4.1(0.16)	14.0(0.55)
6	1/4	-AF-MT6-NS4	37.1(1.46)	15.0(0.59)	4.1(0.16)	19.0(0.75)
8	1/8	-AF-MT8-NS2	35.1(1.38)	10.4(0.41)	5.6(0.22)	14.0(0.55)
8	1/4	-AF-MT8-NS4	37.6(1.48)	15.0(0.59)	5.6(0.22)	19.0(0.75)
8	3/8	-AF-MT8-NS6	36.5(1.44)	15.0(0.59)	5.6(0.22)	22.0(0.87)
10	1/4	-AF-MT10-NS4	38.1(1.50)	15.0(0.59)	7.1(0.28)	19.0(0.75)
10	3/8	-AF-MT10-NS6	40.1(1.58)	15.0(0.59)	7.1(0.28)	22.0(0.87)
10	1/2	-AF-MT10-NS8	46.5(1.83)	19.8(0.78)	7.1(0.28)	27.0(1.06)
12	1/4	-AF-MT12-NS4	43.7(1.72)	15.0(0.59)	8.8(0.35)	19.0(0.75)
12	3/8	-AF-MT12-NS6	42.9(1.69)	15.0(0.59)	8.8(0.35)	22.0(0.87)
12	1/2	-AF-MT12-NS8	52.3(2.06)	19.8(0.78)	8.8(0.35)	27.0(1.06)
16	1/2	-AF-MT16-NS8	49.2(1.94)	19.8(0.78)	12.0(0.47)	27.0(1.06)
18	3/4	-AF-MT18-NS12	52.4(2.06)	20.6(0.81)	14.0(0.55)	32.0(1.26)
20	1/2	-AF-MT20-NS8	50.0(1.97)	19.8(0.78)	15.5(0.61)	27.0(1.06)
20	3/4	-AF-MT20-NS12	57.2(2.25)	20.6(0.81)	15.5(0.61)	35.0(1.38)
25	1	-AF-MT25-NS16	66.7(2.63)	25.4(1.00)	19.8(0.78)	41.0(1.61)

Metric Tube			ISO Tapered Thread (RT)			
T-Tube O.D. (mm)	P-RT Size	Basic Ordering Number	Dimensions, mm (in.)			
			L	B	E	F
3	1/8	-AF-MT3-RT2	28.8(1.13)	10.4(0.41)	1.8(0.07)	14.0(0.55)
4	1/8	-AF-MT4-RT2	28.6(1.13)	10.4(0.41)	2.4(0.09)	14.0(0.55)
6	1/8	-AF-MT6-RT2	33.0(1.30)	10.4(0.41)	4.1(0.16)	14.0(0.55)
8	1/4	-AF-MT8-RT4	37.6(1.48)	15.0(0.59)	5.6(0.22)	19.0(0.75)
10	1/4	-AF-MT10-RT4	38.1(1.50)	15.0(0.59)	7.1(0.28)	19.0(0.75)
10	3/8	-AF-MT10-RT6	36.5(1.44)	15.0(0.59)	7.1(0.28)	22.0(0.87)
10	1/2	-AF-MT10-RT8	41.3(1.63)	19.8(0.78)	7.1(0.28)	27.0(1.06)
12	1/4	-AF-MT12-RT4	43.7(1.72)	15.0(0.59)	8.8(0.35)	19.0(0.75)
12	3/8	-AF-MT12-RT6	43.7(1.72)	15.0(0.59)	8.8(0.35)	22.0(0.87)
12	1/2	-AF-MT12-RT8	46.8(1.84)	19.8(0.78)	8.8(0.35)	27.0(1.06)
16	1/2	-AF-MT16-RT8	48.4(1.91)	19.8(0.78)	12.0(0.47)	27.0(1.06)
18	3/4	-AF-MT18-RT12	52.4(2.06)	20.6(0.81)	14.0(0.55)	32.0(1.26)
20	3/4	-AF-MT20-RT12	52.4(2.06)	20.6(0.81)	15.5(0.61)	32.0(1.26)
25	1	-AF-MT25-RT16	66.7(2.63)	25.4(1.00)	19.8(0.78)	41.0(1.61)

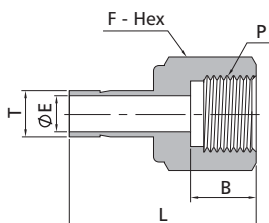

Metric Tube			ISO Parallel Thread (RP)			
T-Tube O.D. (mm)	P-RP Size	Basic Ordering Number	Dimensions, mm (in.)			
			L	B	E	F
6	1/8	-AF-MT6-RP2	32.0(1.26)	10.2(0.40)	4.1(0.16)	14.0(0.55)
6	1/4	-AF-MT6-RP4	37.8(1.49)	15.2(0.60)	4.1(0.16)	19.0(0.75)
12	1/2	-AF-MT12-RP8	49.8(1.96)	18.8(0.74)	8.8(0.35)	27.0(1.06)

Female Adapters

Tube Fittings

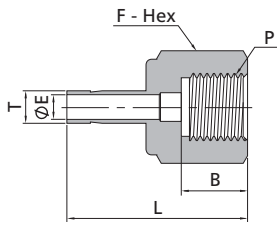

Metric Tube			ISO Parallel Thread (RG)			
T-Tube O.D. (mm)	P-RG Size	Basic Ordering Number	Dimensions, mm (in.)			
			L	B	E	F
3	1/8	-AF-MT3-RG2	28.6(1.13)	9.8(0.39)	1.9(0.07)	14.0(0.55)
3	1/4	-AF-MT3-RG4	33.5(1.32)	12.9(0.50)	1.9(0.07)	19.0(0.75)
4	1/8	-AF-MT4-RG2	29.4(1.16)	9.8(0.39)	2.4(0.09)	14.0(0.55)
6	1/8	-AF-MT6-RG2	29.1(1.15)	9.8(0.39)	4.1(0.16)	14.0(0.55)
6	1/4	-AF-MT6-RG4	35.3(1.39)	12.9(0.50)	4.1(0.16)	19.0(0.75)
6	3/8	-AF-MT6-RG6	38.4(1.51)	14.2(0.56)	4.1(0.16)	24.0(0.94)
6	1/2	-AF-MT6-RG8	42.9(1.69)	18.8(0.74)	4.1(0.16)	27.0(1.06)
8	1/4	-AF-MT8-RG4	33.0(1.30)	12.9(0.50)	5.5(0.22)	19.0(0.75)
8	3/8	-AF-MT8-RG6	38.9(1.53)	14.2(0.56)	5.6(0.22)	24.0(0.94)
8	1/2	-AF-MT8-RG8	43.7(1.72)	18.8(0.74)	5.6(0.22)	27.0(1.06)
10	1/4	-AF-MT10-RG4	34.5(1.36)	12.9(0.50)	5.5(0.22)	19.0(0.75)
10	3/8	-AF-MT10-RG6	36.1(1.42)	14.2(0.56)	6.5(0.26)	24.0(0.94)
10	1/2	-AF-MT10-RG8	41.1(1.62)	18.8(0.74)	7.1(0.28)	27.0(1.06)
12	1/4	-AF-MT12-RG4	40.1(1.58)	12.9(0.50)	5.5(0.22)	19.0(0.75)
12	3/8	-AF-MT12-RG6	44.7(1.76)	14.2(0.56)	6.5(0.26)	24.0(0.94)
12	1/2	-AF-MT12-RG8	48.8(1.92)	18.8(0.74)	7.0(0.28)	27.0(1.06)
16	1/2	-AF-MT16-RG8	49.0(1.93)	18.8(0.74)	7.0(0.28)	27.0(1.06)
18	1/2	-AF-MT18-RG8	49.3(1.94)	18.8(0.74)	7.0(0.28)	27.0(1.06)

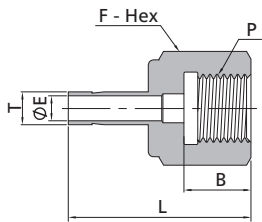

Adapt to Japanese gauge stud.

Metric Tube			ISO Parallel Thread (RJ)			
T-Tube O.D. (mm)	P-RJ Size	Basic Ordering Number	Dimensions, mm (in.)			
			L	B	E	F
6	1/4	-AF-MT6-RJ4	35.3(1.39)	12.9(0.50)	4.1(0.16)	19.0(0.75)
6	3/8	-AF-MT6-RJ6	38.6(1.52)	15.8(0.62)	4.1(0.16)	24.0(0.94)
6	1/2	-AF-MT6-RJ8	42.9(1.69)	18.8(0.74)	4.1(0.16)	27.0(1.06)
8	1/4	-AF-MT8-RJ4	33.0(1.30)	12.9(0.50)	5.5(0.22)	19.0(0.75)
8	3/8	-AF-MT8-RJ6	39.4(1.55)	15.8(0.62)	5.6(0.22)	24.0(0.94)
8	1/2	-AF-MT8-RJ8	43.7(1.72)	18.8(0.74)	5.6(0.22)	27.0(1.06)
10	1/4	-AF-MT10-RJ4	34.5(1.36)	12.9(0.50)	5.5(0.22)	19.0(0.75)
10	3/8	-AF-MT10-RJ6	36.1(1.42)	15.8(0.62)	6.5(0.26)	24.0(0.94)
10	1/2	-AF-MT10-RJ8	41.1(1.62)	18.8(0.74)	7.1(0.28)	27.0(1.06)
12	1/4	-AF-MT12-RJ4	40.1(1.58)	12.9(0.50)	5.5(0.22)	19.0(0.75)
12	3/8	-AF-MT12-RJ6	44.7(1.76)	15.8(0.62)	6.5(0.26)	24.0(0.94)
12	1/2	-AF-MT12-RJ8	48.8(1.92)	18.8(0.74)	7.0(0.28)	27.0(1.06)

Weld Adapters

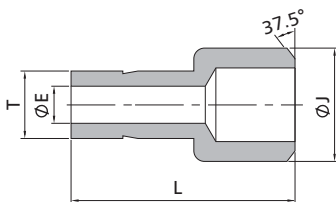

Fractional Tube			Pipe Weld		
T-Tube O.D. (in.)	Pipe Weld Size	Basic Ordering Number	Dimensions, in. (mm)		
			L	J	E
1/4	1/4	-AW-FT4-PB4	1.14(29.0)	0.54(13.7)	0.17(4.3)
3/8	1/2	-AW-FT6-PB8	1.46(37.1)	0.84(21.3)	0.27(6.9)
1/2	1/2	-AW-FT8-PB8	1.66(42.2)	0.84(21.3)	0.37(9.4)
1/2	3/4	-AW-FT8-PB12	1.68(42.7)	1.05(26.7)	0.37(9.4)
3/4	3/4	-AW-FT12-PB12	1.87(47.5)	1.05(26.7)	0.58(14.7)

Flange Adapters

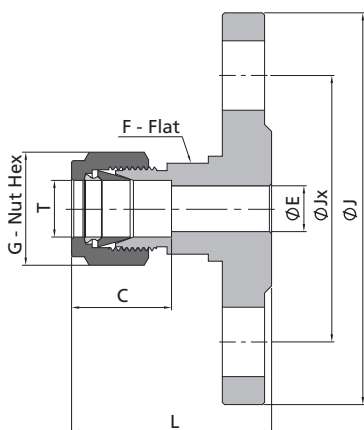

- ⊙ Integrally forged body.
- ⊙ ANSI flanges comply with ANSI B16.5.
- ⊙ DIN flanges comply with DIN 2501/2526.
- ⊙ GB flanges comply with GB/T 9123.1.
- ⊙ EN flanges comply with EN 1092-1.
- ⊙ JIS flanges comply with JIS B 2220.

ANSI Flanges				Dimensions, in. (mm)							
T-Tube O.D. (in.)	ANSI Flange NPS	Class	Basic Ordering Number Raised Face Flange	L	J	Jx	E	C	G	F	
1/4	1/2	150	-FA-FL4-F8-150	1.61(40.9)	3.50(88.9)	2.38(60.5)	0.19(4.8)	0.60(15.2)	0.56(14.3)	0.81(20.6)	
3/8	1/2	300	-FA-FL6-F8-300	1.79(45.5)	3.75(95.3)	2.62(66.5)	0.28(7.1)	0.66(16.8)	0.69(17.5)	0.81(20.6)	
1/2	1/2	150	-FA-FL8-F8-150	1.78(45.2)	3.50(88.9)	2.38(60.5)	0.41(10.4)	0.90(22.9)	0.87(22.2)	0.81(20.6)	
1/2	1	150	-FA-FL8-F16-150	1.90(48.3)	4.25(108.0)	3.12(79.2)	0.41(10.4)	0.90(22.9)	0.87(22.2)	0.81(20.6)	
1/2	2	150	-FA-FL8-F32-150	2.09(53.1)	6.00(152.4)	4.76(121.0)	0.41(10.4)	0.90(22.9)	0.87(22.2)	0.81(20.6)	
3/4	1	150	-FA-FL12-F16-150	1.98(50.3)	4.25(108.0)	3.12(79.2)	0.62(15.7)	0.96(24.4)	1.13(28.6)	1.25(31.8)	
1	1	150	-FA-FL16-F16-150	2.38(60.5)	4.25(108.0)	3.12(79.2)	0.88(22.4)	1.23(31.2)	1.50(38.1)	1.37(34.9)	

DIN/GB Flanges, Pressure Class PN 40				Dimensions, mm (in.)							
T-Tube O.D. (mm)	ANSI Flange Size DN	Basic Ordering Number Raised Face Flange		L	J	Jx	E	C	G	F	
6	25	-FA-ML6-F25-40B1		47.5(1.87)	115.0(4.53)	85.0(3.35)	4.8(0.19)	15.3(0.60)	14.0(0.55)	20.0(0.79)	
12	15	-FA-ML12-F15-40B1		48.5(1.91)	95.0(3.74)	65.0(2.56)	9.5(0.37)	22.8(0.90)	22.0(0.87)	20.0(0.79)	
12	25	-FA-ML12-F25-40B1		50.5(1.99)	115.0(4.53)	85.0(3.35)	9.5(0.37)	22.8(0.90)	22.0(0.87)	20.0(0.79)	
12	50	-FA-ML12-F50-40B1		55.3(2.18)	165.0(6.50)	125.0(4.92)	9.5(0.37)	22.8(0.90)	22.0(0.87)	20.0(0.79)	
18	15	-FA-ML18-F15-40B1		51.8(2.04)	95.0(3.74)	65.0(2.56)	15.1(0.59)	24.4(0.96)	30.0(1.18)	32.0(1.26)	
18	25	-FA-ML18-F25-40B1		53.8(2.12)	115.0(4.53)	85.0(3.35)	15.1(0.59)	24.4(0.96)	30.0(1.18)	32.0(1.26)	
25	25	-FA-ML25-F25-40B1		64.0(2.52)	115.0(4.53)	85.0(3.35)	21.8(0.86)	31.3(1.23)	38.0(1.50)	35.0(1.38)	

Flange Adapters

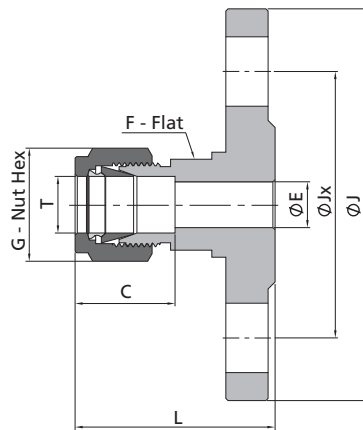

- ⊙ Integrally forged body.
- ⊙ ANSI flanges comply with ANSI B16.5.
- ⊙ DIN flanges comply with DIN 2501/2526.
- ⊙ GB flanges comply with GB/T 9123.1.
- ⊙ EN flanges comply with EN 1092-1.
- ⊙ JIS flanges comply with JIS B 2220.

EN Flanges, Pressure Class PN 40									
T-Tube O.D. (mm)	EN Flange Size DN	Basic Ordering Number Raised Face Flange	Dimensions, mm (in.)						
			L	J	Jx	E	C	G	F
6	25	-FA-ML6-F25E-40B1	47.5(1.87)	115.0(4.53)	85.0(3.35)	4.8(0.19)	15.3(0.60)	14.0(0.55)	20.0(0.79)
12	15	-FA-ML12-F15E-40B1	48.5(1.91)	95.0(3.74)	65.0(2.56)	9.5(0.37)	22.8(0.90)	22.0(0.87)	20.0(0.79)
12	25	-FA-ML12-F25E-40B1	50.5(1.99)	115.0(4.53)	85.0(3.35)	9.5(0.37)	22.8(0.90)	22.0(0.87)	20.0(0.79)
12	50	-FA-ML12-F50E-40B1	55.3(2.18)	165.0(6.50)	125.0(4.92)	9.5(0.37)	22.8(0.90)	22.0(0.87)	20.0(0.79)
18	15	-FA-ML18-F15E-40B1	51.8(2.04)	95.0(3.74)	65.0(2.56)	15.1(0.59)	24.4(0.96)	30.0(1.18)	32.0(1.26)
18	25	-FA-ML18-F25E-40B1	53.8(2.12)	115.0(4.53)	85.0(3.35)	15.1(0.59)	24.4(0.96)	30.0(1.18)	32.0(1.26)
25	25	-FA-ML25-F25E-40B1	64.0(2.52)	115.0(4.53)	85.0(3.35)	21.8(0.86)	31.3(1.23)	38.0(1.50)	35.0(1.38)

JIS Flanges, Pressure Class 10K									
T-Tube O.D.	JIS Flange Size DN	Basic Ordering Number Raised Face Flange	Dimensions, in. (mm)						
			L	J	Jx	E	C	G	F
1/4"	15	-FA-FL4-F15-10KRF	1.66(42.2)	3.74(95.0)	2.76(70.1)	0.19(4.8)	0.60(15.2)	0.56(14.3)	0.81(20.6)
3/8"	15	-FA-FL6-F15-10KRF	1.72(43.7)	3.74(95.0)	2.76(70.1)	0.28(7.1)	0.66(16.8)	0.69(17.5)	0.81(20.6)
1/2"	15	-FA-FL8-F15-10KRF	1.83(46.5)	3.74(95.0)	2.76(70.1)	0.41(10.4)	0.90(22.9)	0.87(22.2)	0.81(20.6)
3/4"	15	-FA-FL12-F15-10KRF	1.91(48.5)	3.74(95.0)	2.76(70.1)	0.62(15.7)	0.96(24.4)	1.13(28.6)	1.25(31.8)
1"	25	-FA-FL16-F25-10KRF	2.40(61.0)	4.92(125.0)	3.54(89.9)	0.88(22.4)	1.23(31.2)	1.50(38.1)	1.37(34.9)
12mm	15	-FA-ML12-F15-10KRF	1.83(46.5)	3.74(95.0)	2.76(70.0)	0.37(9.5)	0.90(22.8)	0.87(22.0)	0.79(20.0)
18mm	15	-FA-ML18-F15-10KRF	1.91(48.5)	3.74(95.0)	2.76(70.0)	0.59(15.1)	0.96(24.4)	1.18(30.0)	1.26(32.0)
25mm	25	-FA-ML25-F25-10KRF	2.40(61.0)	4.92(125.0)	3.54(90.0)	0.86(21.8)	1.23(31.3)	1.50(38.0)	1.38(35.0)

Weld Connectors

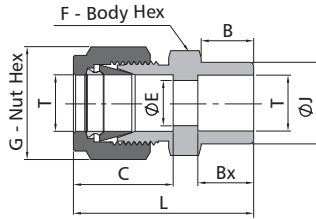

Fractional Tube		Tube Socket Weld							
T-Tube O.D. (in.)	Basic Ordering Number	Dimensions, in. (mm)							
		L	C	G	F	B	E	Bx	J
1/8	-CW-FL2-TS2	1.14(29.0)	0.50(12.7)	0.44(11.1)	0.44(11.1)	0.34(8.6)	0.09(2.3)	0.10(2.5)	0.31(7.9)
3/16	-CW-FL3-TS3	1.17(29.7)	0.54(13.7)	0.50(12.7)	0.44(11.1)	0.37(9.5)	0.13(3.3)	0.19(4.8)	0.42(10.7)
1/4	-CW-FL4-TS4	1.32(33.5)	0.60(15.2)	0.56(14.3)	0.50(12.7)	0.41(10.4)	0.19(4.8)	0.28(7.1)	0.48(12.2)
3/8	-CW-FL6-TS6	1.48(37.6)	0.66(16.8)	0.69(17.5)	0.63(15.9)	0.47(11.9)	0.28(7.1)	0.31(7.9)	0.62(15.7)
1/2	-CW-FL8-TS8	1.62(41.1)	0.90(22.9)	0.87(22.2)	0.81(20.6)	0.47(11.9)	0.41(10.4)	0.50(12.7)	0.75(19.1)
5/8	-CW-FL10-TS10	1.65(41.9)	0.96(24.4)	1.00(25.4)	0.94(23.8)	0.47(11.9)	0.50(12.7)	0.41(10.4)	0.92(23.4)
3/4	-CW-FL12-TS12	1.71(43.4)	0.96(24.4)	1.13(28.6)	1.06(27.0)	0.47(11.9)	0.62(15.7)	0.44(11.1)	1.05(26.7)
1	-CW-FL16-TS16	2.07(52.6)	1.23(31.2)	1.50(38.1)	1.37(34.9)	0.56(14.2)	0.88(22.4)	0.62(15.7)	1.36(34.5)

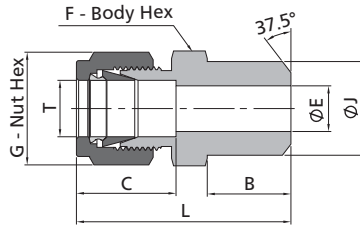

Fractional Tube			Pipe Butt Weld						
T-Tube O.D. (in.)	Pipe Weld Size	Basic Ordering Number	Dimensions, in. (mm)						
			L	C	G	F	E	B	J
1/8	1/8	-CW-FL2-PB2	1.20(30.5)	0.50(12.7)	0.44(11.1)	0.44(11.1)	0.09(2.3)	0.38(9.7)	0.41(10.3)
3/16	1/8	-CW-FL3-PB2	1.23(31.2)	0.54(13.7)	0.50(12.7)	0.44(11.1)	0.12(3.0)	0.38(9.7)	0.41(10.3)
1/4	1/8	-CW-FL4-PB2	1.29(32.8)	0.60(15.2)	0.56(14.3)	0.50(12.7)	0.19(4.8)	0.38(9.7)	0.41(10.3)
1/4	1/4	-CW-FL4-PB4	1.49(37.8)	0.60(15.2)	0.56(14.3)	0.56(14.3)	0.19(4.8)	0.56(14.2)	0.54(13.7)
5/16	1/8	-CW-FL5-PB2	1.34(34.0)	0.64(16.3)	0.63(15.9)	0.56(14.3)	0.21(5.3)	0.38(9.7)	0.41(10.3)
5/16	1/4	-CW-FL5-PB4	1.52(38.6)	0.64(16.3)	0.63(15.9)	0.56(14.3)	0.25(6.4)	0.56(14.2)	0.54(13.7)
3/8	1/4	-CW-FL6-PB4	1.57(39.9)	0.66(16.8)	0.69(17.5)	0.63(15.9)	0.28(7.1)	0.56(14.2)	0.54(13.7)
3/8	3/8	-CW-FL6-PB6	1.57(39.9)	0.66(16.8)	0.69(17.5)	0.69(17.5)	0.28(7.1)	0.56(14.2)	0.67(17.1)
3/8	1/2	-CW-FL6-PB8	1.82(46.2)	0.66(16.8)	0.69(17.5)	0.87(22.2)	0.28(7.1)	0.75(19.1)	0.84(21.3)
3/8	3/4	-CW-FL6-PB12	1.88(47.8)	0.66(16.8)	0.69(17.5)	1.06(27.0)	0.28(7.1)	0.75(19.1)	1.05(26.7)
1/2	3/8	-CW-FL8-PB6	1.71(43.4)	0.90(22.9)	0.87(22.2)	0.81(20.6)	0.41(10.4)	0.56(14.2)	0.67(17.1)
1/2	1/2	-CW-FL8-PB8	1.93(49.0)	0.90(22.9)	0.87(22.2)	0.87(22.2)	0.41(10.4)	0.75(19.1)	0.84(21.3)
1/2	3/4	-CW-FL8-PB12	1.99(50.5)	0.90(22.9)	0.87(22.2)	1.06(27.0)	0.41(10.4)	0.75(19.1)	1.05(26.7)
5/8	1/2	-CW-FL10-PB8	1.93(49.0)	0.96(24.4)	1.00(25.4)	0.94(23.8)	0.50(12.7)	0.75(19.1)	0.84(21.3)
3/4	1/2	-CW-FL12-PB8	1.99(50.5)	0.96(24.4)	1.13(28.6)	1.06(27.0)	0.55(14.0)	0.75(19.1)	0.84(21.3)
3/4	3/4	-CW-FL12-PB12	1.99(50.5)	0.96(24.4)	1.13(28.6)	1.06(27.0)	0.62(15.7)	0.75(19.1)	1.05(26.7)
1	1	-CW-FL16-PB16	2.45(62.2)	1.23(31.2)	1.50(38.1)	1.37(34.9)	0.88(22.4)	0.94(23.9)	1.31(33.4)
1 1/4	1 1/4	-CW-FL20-PB20	3.04(77.2)	1.62(41.1)	1.87(47.6)	1.75(44.5)	1.09(27.7)	0.94(23.9)	1.66(42.2)
1 1/2	1 1/2	-CW-FL24-PB24	3.50(88.9)	1.97(50.0)	2.25(57.2)	2.13(54.0)	1.34(34.0)	1.03(26.2)	1.90(48.3)

Weld Connectors

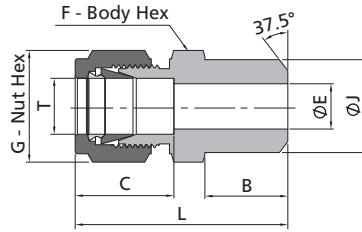

Metric Tube			Pipe Butt Weld						
T-Tube O.D. (mm)	Pipe Weld Size	Basic Ordering Number	Dimensions, mm (in.)						
			L	C	G	F	E	B	J
3	1/8	-CW-ML3-PB2	30.5(1.20)	12.9(0.51)	12.0(0.47)	12.0(0.47)	2.4(0.09)	9.7(0.38)	10.3(0.41)
4	1/8	-CW-ML4-PB2	31.5(1.24)	13.7(0.54)	12.0(0.47)	12.0(0.47)	2.4(0.09)	9.7(0.38)	10.3(0.41)
6	1/8	-CW-ML6-PB2	32.8(1.29)	15.3(0.60)	14.0(0.55)	14.0(0.55)	4.8(0.19)	9.7(0.38)	10.3(0.41)
6	1/4	-CW-ML6-PB4	37.9(1.49)	15.3(0.60)	14.0(0.55)	14.0(0.55)	4.8(0.19)	14.2(0.56)	13.7(0.54)
8	1/8	-CW-ML8-PB2	34.2(1.35)	16.2(0.64)	16.0(0.63)	15.0(0.59)	5.4(0.21)	9.7(0.38)	10.3(0.41)
8	1/4	-CW-ML8-PB4	38.7(1.52)	16.2(0.64)	16.0(0.63)	15.0(0.59)	6.4(0.25)	14.2(0.56)	13.7(0.54)
8	1/2	-CW-ML8-PB8	45.6(1.80)	16.2(0.64)	16.0(0.63)	22.0(0.87)	6.4(0.25)	19.1(0.75)	21.3(0.84)
10	1/4	-CW-ML10-PB4	40.9(1.60)	17.2(0.70)	19.0(0.75)	18.0(0.71)	7.5(0.30)	14.2(0.56)	13.7(0.54)
10	3/8	-CW-ML10-PB6	40.9(1.60)	17.2(0.70)	19.0(0.75)	18.0(0.71)	7.9(0.31)	14.2(0.56)	17.1(0.67)
10	1/2	-CW-ML10-PB8	46.5(1.80)	17.2(0.70)	19.0(0.75)	22.0(0.87)	7.9(0.31)	19.1(0.75)	21.3(0.84)
12	1/4	-CW-ML12-PB4	43.4(1.70)	22.8(0.90)	22.0(0.87)	22.0(0.87)	7.5(0.30)	14.2(0.56)	13.7(0.54)
12	3/8	-CW-ML12-PB6	43.4(1.70)	22.8(0.90)	22.0(0.87)	22.0(0.87)	9.5(0.37)	14.2(0.56)	17.1(0.67)
12	1/2	-CW-ML12-PB8	49.0(1.90)	22.8(0.90)	22.0(0.87)	22.0(0.87)	9.5(0.37)	19.1(0.75)	21.3(0.84)
14	3/8	-CW-ML14-PB6	44.1(1.70)	24.4(0.96)	25.0(0.98)	24.0(0.94)	10.7(0.42)	14.2(0.56)	17.1(0.67)
15	1/2	-CW-ML15-PB8	49.0(1.90)	24.4(0.96)	25.0(0.98)	24.0(0.94)	11.9(0.47)	19.1(0.75)	21.3(0.84)
16	1/2	-CW-ML16-PB8	49.0(1.90)	24.4(0.96)	25.0(0.98)	24.0(0.94)	12.7(0.50)	19.1(0.75)	21.3(0.84)
18	1/2	-CW-ML18-PB8	50.5(2.00)	24.4(0.96)	30.0(1.18)	27.0(1.06)	13.9(0.55)	19.1(0.75)	21.3(0.84)
30	1 1/4	-CW-ML30-PB20	77.2(3.00)	39.6(1.60)	50.0(1.97)	46.0(1.81)	26.2(1.03)	23.9(0.94)	42.2(1.66)
32	1 1/4	-CW-ML32-PB20	79.6(3.10)	42.0(1.70)	50.0(1.97)	46.0(1.81)	28.6(1.13)	23.9(0.94)	42.2(1.66)
38	1 1/2	-CW-ML38-PB24	91.6(3.60)	49.4(1.90)	60.0(2.36)	55.0(2.17)	33.7(1.33)	26.2(1.03)	48.3(1.9)

Weld Elbows

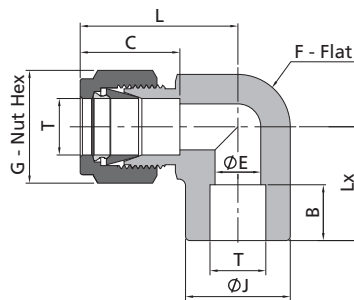

Fractional Tube		Tube Socket Weld							
T-Tube O.D. (in.)	Basic Ordering Number	Dimensions, in. (mm)							
		L	C	G	F	B	E	Lx	J
1/8	-LW-FL2-TS2	0.66(16.8)	0.50(12.7)	0.44(11.1)	0.37(9.5)	0.10(2.5)	0.09(2.3)	0.63(16.0)	0.38(9.7)
3/16	-LW-FL3-TS3	0.72(18.3)	0.54(13.7)	0.50(12.7)	0.44(11.1)	0.19(4.8)	0.13(3.3)	0.69(17.5)	0.44(11.2)
1/4	-LW-FL4-TS4	1.06(26.9)	0.60(15.2)	0.56(14.3)	0.50(12.7)	0.28(7.1)	0.19(4.8)	0.77(19.6)	0.50(12.7)
3/8	-LW-FL6-TS6	1.20(30.5)	0.66(16.8)	0.69(17.5)	0.63(15.9)	0.31(7.9)	0.28(7.1)	0.91(23.1)	0.62(15.7)
1/2	-LW-FL8-TS8	1.42(36.1)	0.90(22.9)	0.87(22.2)	0.81(20.6)	0.38(9.7)	0.41(10.4)	1.02(25.9)	0.81(20.6)
5/8	-LW-FL10-TS10	1.16(29.5)	0.96(24.4)	1.00(25.4)	1.06(27.0)	0.41(10.4)	0.50(12.7)	1.16(29.5)	0.94(23.9)
3/4	-LW-FL12-TS12	1.57(39.9)	0.96(24.4)	1.13(28.6)	1.06(27.0)	0.44(11.2)	0.62(15.7)	1.17(29.7)	1.06(26.9)
1	-LW-FL16-TS16	1.93(49.0)	1.23(31.2)	1.50(38.1)	1.37(34.9)	0.62(15.7)	0.88(22.4)	1.45(36.8)	1.38(35.1)

Weld Elbows

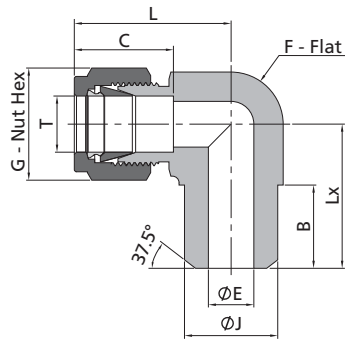

Fractional Tube			Pipe Butt Weld							
T-Tube O.D. (in.)	Pipe Weld Size	Basic Ordering Number	Dimensions, in. (mm)							
			L	C	G	F	B	E	Lx	J
1/8	1/8	-LW-FL2-PB2	0.92(23.4)	0.50(12.7)	0.44(11.1)	0.44(11.1)	0.38(9.7)	0.09(2.3)	0.72(18.3)	0.41(10.3)
3/16	1/8	-LW-FL3-PB2	1.01(25.7)	0.54(13.7)	0.50(12.7)	0.50(12.7)	0.38(9.7)	0.12(3.0)	0.74(18.8)	0.41(10.3)
1/4	1/8	-LW-FL4-PB2	1.06(26.9)	0.60(15.2)	0.56(14.3)	0.50(12.7)	0.38(9.7)	0.19(4.8)	0.74(18.8)	0.41(10.3)
1/4	1/4	-LW-FL4-PB4	1.06(26.9)	0.60(15.2)	0.56(14.3)	0.50(12.7)	0.56(14.2)	0.19(4.8)	0.92(23.4)	0.54(13.7)
3/8	1/4	-LW-FL6-PB4	1.20(30.5)	0.66(16.8)	0.69(17.5)	0.63(15.9)	0.56(14.2)	0.28(7.1)	1.00(25.4)	0.54(13.7)
1/2	3/8	-LW-FL8-PB6	1.37(34.8)	0.90(22.9)	0.87(22.2)	0.81(20.6)	0.56(14.2)	0.41(10.4)	1.13(28.8)	0.67(17.1)
1/2	1/2	-LW-FL8-PB8	1.42(36.1)	0.90(22.9)	0.87(22.2)	0.81(20.6)	0.75(19.1)	0.41(10.4)	1.30(33.0)	0.84(21.3)
5/8	1/2	-LW-FL10-PB8	1.43(36.3)	0.96(24.4)	1.00(25.4)	0.94(23.8)	0.75(19.1)	0.50(12.7)	1.38(35.1)	0.84(21.3)
3/4	3/4	-LW-FL12-PB12	1.57(39.9)	0.96(24.4)	1.13(28.6)	1.06(27.0)	0.75(19.1)	0.62(15.7)	1.45(36.8)	1.05(26.7)
1	3/4	-LW-FL16-PB12	1.94(49.3)	1.23(31.2)	1.50(38.1)	1.37(34.9)	0.75(19.1)	0.74(18.8)	1.65(41.9)	1.05(26.7)
1	1	-LW-FL16-PB16	1.94(49.3)	1.23(31.2)	1.50(38.1)	1.37(34.9)	0.94(23.9)	0.88(22.4)	1.84(46.7)	1.31(33.4)

Automatic Tube Weld Connectors

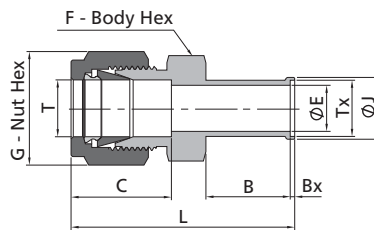

Fractional Tube			Automatic Tube Weld							
T-Tube O.D. (in.)	Tx-Tube O.D. (in.)	Basic Ordering Number	Dimensions, in. (mm)							
			L	C	G	F	B	E	Bx	J
1/4	1/4	-CW-FL4-TB4A	1.74(44.2)	0.60(15.2)	0.56(14.3)	0.50(12.7)	0.75(19.1)	0.18(4.5)	0.02(0.5)	0.29(7.4)
3/8	3/8	-CW-FL6-TB6A	1.84(46.7)	0.66(16.8)	0.69(17.5)	0.63(15.9)	0.75(19.1)	0.31(7.8)	0.03(0.8)	0.41(10.4)
1/2	1/2	-CW-FL8-TB8A	1.99(50.5)	0.90(22.9)	0.87(22.2)	0.81(20.6)	0.75(19.1)	0.41(10.4)	0.04(1.0)	0.55(14.0)

Calibration Fittings

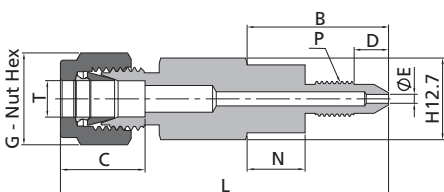

- The calibration fittings can be connected directly with the bleed port of the transmitter so that the calibration process can be simplified.
- Two types are available to fit the bleed ports of the transmitters.

T-Tube O.D. (in.)	P-SAE/MS Thread Size	Basic Ordering Number	Dimensions, in. (mm)						
			L	B	C	D	E	G	N
1/4	1/4-28	-FC-FL4-1428	1.69(42.9)	0.78(19.8)	0.60(15.2)	0.43(10.9)	0.06(1.5)	0.56(14.3)	—
1/4	5/16-24	-FC-FL4-51624	2.32(58.9)	1.41(35.8)	0.60(15.2)	0.40(10.2)	0.06(1.5)	0.56(14.3)	0.41(10.4)

Dielectric Fittings

Materials

Component	Material
Insulator	Polyamide-imide
O-Ring	70 Durometer FKM
Backup Ring	Virgin PTFE

Technical Data

- ⦿ Electrical Resistance of Insulators at 70°F (20°C): 10×10⁶ Ω at 10 V
- ⦿ Maximum working pressure: 5000 psig (344 bar) at 70°F (21°C)
- ⦿ Temperature range: -40°F (-40°C) to 200°F (93°C)

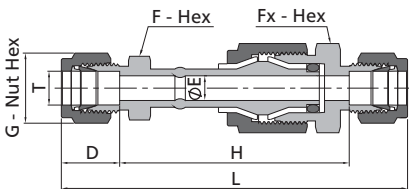

Fractional Tube								
T-Tube O.D. (in.)	Basic Ordering Number	Dimensions, in. (mm)						
		L	D	G	H	E	F	Fx
1/4	-DF-FL4	3.77(95.7)	0.60(15.2)	0.56(14.3)	2.57(65.3)	0.19(4.8)	0.50(12.7)	0.81(20.6)
3/8	-DF-FL6	3.92(99.6)	0.66(16.8)	0.69(17.5)	2.59(65.8)	0.28(7.1)	0.63(15.9)	0.81(20.6)
1/2	-DF-FL8	4.17(106.0)	0.90(22.9)	0.87(22.2)	2.37(60.2)	0.28(7.1)	0.81(20.6)	0.81(20.6)

Metric Tube								
T-Tube O.D. (mm)	Basic Ordering Number	Dimensions, mm (in.)						
		L	D	G	H	E	F	Fx
12	-DF-ML12	107.0(4.21)	22.8(0.90)	22.0(0.87)	61.7(2.43)	7.1(0.28)	22.0(0.87)	22.0(0.87)

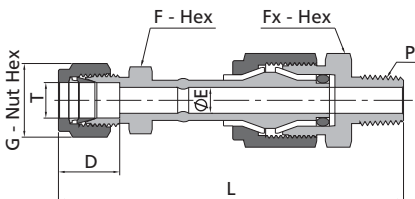

Fractional Tube			NPT Thread					
T-Tube O.D. (in.)	P-NPT Size	Basic Ordering Number	Dimensions, in. (mm)					
			L	D	G	E	F	Fx
3/8	1/4	-DF-FL6-NS4	3.73(94.7)	0.66(16.8)	0.69(17.5)	0.28(7.1)	0.63(15.9)	0.87(22.2)

RS, RSD Gaskets

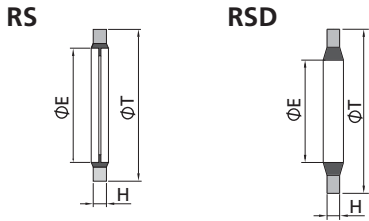

The RS and RSD gaskets provide a seal with male ISO parallel threads. The gasket consists of a fluorocarbon FKM or Buna inner ring bonded to a carbon steel or stainless steel outer ring.

ISO Parallel Thread Size	Basic Ordering Number	Dimensions, in. (mm)		
		T	E	H
1/8	-RS-2	0.63(16.0)	0.41(10.4)	0.08(2.0)
1/4	-RS-4	0.81(20.6)	0.54(13.7)	
3/8	-RS-6	0.94(23.9)	0.68(17.3)	
1/2	-RS-8	1.13(28.7)	0.85(21.6)	0.10(2.5)
3/4	-RS-12	1.38(35.1)	1.06(26.9)	
1	-RS-16	1.69(42.9)	1.33(33.8)	
1/8	-RSD-2	0.58(14.7)	0.47(12)	0.05(1.25)
1/4	-RSD-4	0.74(18.7)	0.62(15.75)	
3/8	-RSD-6	0.89(22.7)	0.76(19.25)	
1/2	-RSD-8	1.05(26.7)	0.93(23.55)	0.08(2)
3/4	-RSD-12	1.28(32.5)	1.15(29.2)	
1	-RSD-16	1.56(39.5)	1.42(36.1)	

RS-M Gaskets

Metric Thread Size	Basic Ordering Number	Dimensions, mm (in.)		
		T	E	H
M8 x 1	-RS-M8	13.0(0.51)	8.7(0.34)	1.0(0.04)
M10 x 1	-RS-M10	16.0(0.63)	10.7(0.42)	1.5(0.06)
M12 x 1.5	-RS-M12	18.0(0.63)	12.7(0.42)	
M14 x 1.5	-RS-M14	22.0(0.71)	14.7(0.50)	
M16 x 1.5	-RS-M16	24.0(0.87)	16.7(0.66)	2.0(0.08)
M18 x 1.5	-RS-M18	26.0(0.94)	18.7(0.74)	
M20 x 1.5	-RS-M20	28.0(1.02)	20.7(0.81)	
M22 x 1.5	-RS-M22	30.0(1.10)	22.7(0.89)	2.5(0.10)
M24 x 1.5	-RS-M24	32.0(1.20)	24.7(1.00)	
M27 x 2	-RS-M27	36.0(1.30)	27.2(1.10)	
M30 x 2	-RS-M30	39.0(1.40)	30.7(1.20)	3.0(0.12)
M33 x 2	-RS-M33	42.0(1.50)	33.7(1.30)	
M36 x 2	-RS-M36	48.0(1.70)	37.0(1.50)	
M39 x 2	-RS-M39	51.0(1.90)	40.0(1.60)	3.0(0.12)
M42 x 2	-RS-M42	53.0(2.00)	42.7(1.70)	
M45 x 2	-RS-M45	57.0(2.10)	46.0(1.80)	
M48 x 2	-RS-M48	59.0(2.20)	48.7(1.90)	

Ordering Information

Add the material designator as a prefix to the basic ordering number to complete the ordering number.

Ring		Designator
Outer	Inner	
Stainless Steel	FKM	SSF
Carbon Steel	FKM	CSF
	Buna-N	CSB

Example:

1. A RS gasket with a Buna inner ring bonded to carbon steel outer ring provides a seal with 1/8 male ISO parallel thread, the complete ordering number is CSB-RS-2.
 2. A RSD gasket with an FKM inner ring bonded to stainless steel outer ring provides a seal with 1/4 male ISO parallel thread, the complete ordering number is SSF-RSD-4.
- The RS and RSD gaskets can be used with RS fitting only.

RP Gaskets



The RP gasket provides a seal with male ISO parallel threads. The RP gasket may be used with a RS fitting.

ISO Parallel Thread Size	Basic Ordering Number	Dimensions, in. (mm)		
		T	E	H
1/8	-RP-2	0.59(15.0)	0.39(9.9)	0.04(1.0)
1/4	-RP-4	0.75(19.1)	0.52(13.2)	0.06(1.5)
3/8	-RP-6	0.91(23.1)	0.66(16.8)	
1/2	-RP-8	1.06(26.9)	0.83(21.1)	
3/4	-RP-12	1.30(33.0)	1.05(26.7)	0.08(2.0)
1	-RP-16	1.58(40.1)	1.31(33.2)	

RP-M Gaskets

Metric Thread Size	Basic Ordering Number	Dimensions, mm (in.)		
		T	E	H
M8 x 1	-RP-M8	13.2(0.52)	8.2(0.32)	1.5(0.06)
M10 x 1	-RP-M10	15.2(0.60)	10.2(0.40)	
M12 x 1.5	-RP-M12	18.2(0.60)	12.2(0.40)	
M14 x 1.5	-RP-M14	20.2(0.72)	14.2(0.48)	2.0(0.08)
M16 x 1.5	-RP-M16	22.2(0.80)	16.2(0.64)	
M18 x 1.5	-RP-M18	24.2(0.87)	18.2(0.72)	
M20 x 1.5	-RP-M20	26.2(0.95)	20.2(0.80)	2.5(0.10)
M22 x 1.5	-RP-M22	28.2(1.03)	22.2(0.87)	
M24 x 1.5	-RP-M24	30.2(1.10)	24.2(1.00)	
M27 x 2	-RP-M27	33.3(1.20)	27.2(1.10)	2.5(0.10)
M30 x 2	-RP-M30	37.3(1.30)	30.2(1.20)	
M33 x 2	-RP-M33	40.3(1.50)	33.2(1.30)	
M36 x 2	-RP-M36	43.3(1.60)	36.2(1.40)	2.5(0.10)
M39 x 2	-RP-M39	47.3(1.70)	39.2(1.50)	
M42 x 2	-RP-M42	50.3(1.90)	42.2(1.70)	
M45 x 2	-RP-M45	53.3(2.00)	45.2(1.80)	2.5(0.10)
M48 x 2	-RP-M48	56.3(2.10)	48.2(1.90)	

A-84 6 Series Tube Fittings

RG Gaskets

The RG gasket provides a seal on pressure gauges equipped with male ISO parallel threads.

ISO Parallel Thread Size	Basic Ordering Number	Dimensions, in. (mm)		
		T	E	H
1/4	-RG-4	0.42(10.7)	0.30(7.6)	0.07(1.8)
3/8	-RG-6	0.56(14.2)	0.34(8.6)	0.09(2.3)
1/2	-RG-8	0.70(17.8)	0.36(9.1)	0.10(2.5)

RG-M Gaskets

ISO Parallel Thread Size	Basic Ordering Number	Dimensions, in. (mm)		
		T	E	H
M10 x 1	-RG-M10	8.3(0.33)	3.3(0.13)	1.5(0.06)
M12 x 1.5	-RG-M12	9.7(0.38)	5.4(0.21)	2.0(0.08)
M14 x 1.5	-RG-M14	11.7(0.38)	6.4(0.21)	
M16 x 1.5	-RG-M16	13.7(0.46)	8.4(0.25)	
M18 x 1.5	-RG-M18	15.7(0.54)	10.0(0.39)	
M20 x 1.5	-RG-M20	17.6(0.62)	11.4(0.45)	
M22 x 1.5	-RG-M22	19.6(0.69)	13.4(0.53)	
M24 x 1.5	-RG-M24	21.6(0.77)	14.8(0.58)	2.5(0.10)
M27 x 2	-RG-M27	24.0(0.90)	13.9(0.50)	
M30 x 2	-RG-M30	27.0(0.90)	19.5(0.80)	
M33 x 2	-RG-M33	30.0(1.10)	21.5(0.80)	
M36 x 2	-RG-M36	33.0(1.20)	23.5(0.90)	
M39 x 2	-RG-M39	36.0(1.30)	24.5(1.00)	
M42 x 2	-RG-M42	38.9(1.40)	29.5(1.20)	
M45 x 2	-RG-M45	41.9(1.50)	30.0(1.20)	
M48 x 2	-RG-M48	44.9(1.60)	32.5(1.30)	

RJ Gaskets

The RJ gasket provides a seal on Japanese pressure gauges equipped with male ISO parallel threads.

ISO Parallel Thread Size	Basic Ordering Number	Dimensions, in. (mm)		
		T	E	H
1/4	-RJ-4	0.43(10.9)	0.22(5.6)	0.04(1.0)
3/8	-RJ-6	0.55(13.9)	0.22(5.6)	0.04(1.0)
1/2	-RJ-8	0.70(17.8)	0.22(5.6)	0.04(1.0)

Ordering Information

Add the material designator as a prefix to the basic ordering number to complete the ordering number.

Material	Designator
Copper	CU
316L SS	6L
Vulcanized Fibre	QB
PTFE	T

Vulcanized Fibre and PTFE cannot be used for RP gasket.

Example:

CU-RP-2, 6L-RG-6, QB-RG-M20, T-RJ-8.

O-rings



O-rings for Fittings with SAE/MS Straight Threads

SAE/MS Thread Size	Ordering Number	Material
5/16-24	VI9-902	90 Durometer Fluorocarbon FKM
3/8-24	VI9-903	
7/16-20	VI9-904	
1/2-20	VI9-905	
9/16-18	VI9-906	
3/4-16	VI9-908	
7/8-14	VI9-910	
1 1/16-12	VI9-912	
1 3/16-12	VI9-914	
1 5/16-12	VI9-916	
1 5/8-12	VI9-920	
1 7/8-12	VI9-924	

O-rings for Fittings with O-Seal Pipe Threads

NPT/ISO Thread Size	Ordering Number	Material
1/8	BN7-013	70 Durometer NBR
1/4	BN7-113	
3/8	BN7-116	
1/2	BN7-118	

A-86 6 Series Tube Fittings

O-rings for Adjustable Fittings with ISO Parallel Threads

ISO Parallel Thread Size	Ordering Number	Material
1/8	VI9-502	90 Durometer Fluorocarbon FKM
1/4	VI9-111	
3/8	VI9-113	
1/2	VI9-508	
3/4	VI9-119	
1	VI9-217	

O-rings for Fittings with O-Seal Straight Threads

SAE/MS Thread Size	Ordering Number	Material
5/16-24	BN7-011	70 Durometer NBR
3/8-24	BN7-012	
7/16-20	BN7-013	
1/2-20	BN7-112	
9/16-18	BN7-113	
3/4-16	BN7-116	
1 1/16-12	BN7-121	
1 5/16-12	BN7-125	

O-rings for Fittings with Metric Threads

SAE/MS Thread Size	Ordering Number	Material
M14 x 1.5	BN9-M14	90 Durometer NBR
M20 x 1.5	BN9-M20	

Ordering Number Description

SS - CM - ML12 - NS8 - □ - □ - □ - □

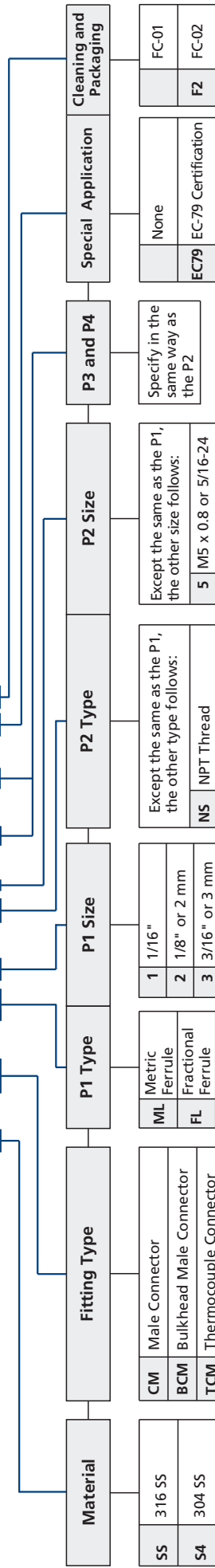

Material	Fitting Type	P1 Type	P1 Size	P2 Type	P2 Size	P3 and P4	Special Application	Cleaning and Packaging
SS	CM	ML	1 1/16"	NS	5		None	FC-01
S4	BCM	FL	1/8" or 2 mm	ONS	6		EC79	FC-02
S1	TCM	MT	3/16" or 3 mm	RT	7		EC79	FC-02
S12	CF	FT	1/4" or 4 mm	RS	8			
904L	BCF		5/16"	RP	9			
904L SS	U		3/8" or 6 mm	RG	10			
TI	BU		1/2" or 8 mm	RJ	11			
TI	LM		5/8" or 10 mm	PP	12			
TI	VM		3/4" or 12 mm	ST	13			
D5	VP		7/8" or 14 mm	OST	14			
D5	VP		15 mm	AN	15			
D7	LP		1" or 16 mm	MS	16			
D7	LP		1 1/8" or 18 mm	TS	17			
A20	LF		1 1/4" or 20 mm	PB	18			
A20	LF		22 mm		19			
M	LU		24 1/2" or 24 mm		20			
M	LU		25 mm		21			
INC	TMT		28 mm		22			
INC	TMT		30 mm		23			
INC	TMT		32" or 32 mm		24			
INC	TMT		38 mm		25			
INC	TMT		50 mm		26			
A65	TPT				27			
A65	TPT				28			
A65	TPT				29			
A65	TPT				30			
HC	TFT				31			
HC	TFT				32			
CS	TTF				33			
CS	TTF				34			
AL	TTT				35			
AL	TTT				36			
B	C				37			
B	C				38			
B	C				39			
B	C				40			
PA	TC				41			
PA	TC				42			
PA	TC				43			
PA	TC				44			
PA	TC				45			
PA	TC				46			
PA	TC				47			
PA	TC				48			
PA	TC				49			
PA	TC				50			
T	TP				51			
T	TP				52			
T	TP				53			
T	TP				54			
T	TP				55			
T	TP				56			
T	TP				57			
T	TP				58			
T	TP				59			
T	TP				60			
T	TP				61			
T	TP				62			
T	TP				63			
T	TP				64			
T	TP				65			
T	TP				66			
T	TP				67			
T	TP				68			
T	TP				69			
T	TP				70			
T	TP				71			
T	TP				72			
T	TP				73			
T	TP				74			
T	TP				75			
T	TP				76			
T	TP				77			
T	TP				78			
T	TP				79			
T	TP				80			
T	TP				81			
T	TP				82			
T	TP				83			
T	TP				84			
T	TP				85			
T	TP				86			
T	TP				87			
T	TP				88			
T	TP				89			
T	TP				90			
T	TP				91			
T	TP				92			
T	TP				93			
T	TP				94			
T	TP				95			
T	TP				96			
T	TP				97			
T	TP				98			
T	TP				99			
T	TP				100			

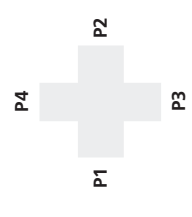

- P1, P2, P3 and P4 shall be described in the following orders:
- Ferrule - Tube - NPT Thread - ISO Tapered Thread - ISO Parallel Thread - SAE/MS Straight Thread - 37° Flare - Pipe Butt Weld - Fractional Tube Socket Weld - Others
 - Describe in descending order as per size if the end connection types are the same
 - Describe the end of P1 if all end connections are the same
- Cleaning and Packaging:
- FC-01: Standard cleaning and packaging for general industrial procedures
 - FC-02: Special cleaning and packaging for wetted system components to ensure compliance with product cleanliness requirement as stated in ASTM G93 Level C

Note: "Ordering Number Description" is a reference to understand the combination rules of FITOK product part number. Not all combinations are available.

info@fitokgroup.com
www.fitokgroup.com

FK-IC-GF-01-EN-190912

37° Flared Tube Fittings



Contents

Tube Cap Assembly - TCA



A-92

Nuts - N



A-92

Male Connectors - CM

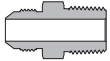

A-92

Female Connectors - CF



A-94

Unions - U



A-95

Large Hex Unions - HU

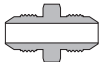

A-95

Reducing Adapters - RA



A-95

Sleeves - SL



A-95

Bulkhead Unions - BU

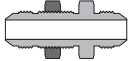

A-96

Bulkhead Lock Nuts - BN



A-96

Tube Caps - TC



A-96

Tube Plugs - TP



A-96

Male Elbows - LM

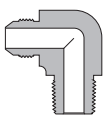

A-97

Adjustable Male Elbows - LP

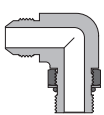

A-97

45° Male Elbows - VM

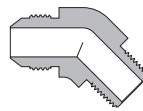

A-98

Female Elbows - LF

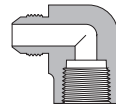

A-98

Union Elbows - LU

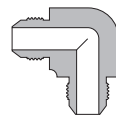

A-99

Male Branch Tees - TTM

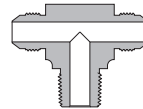

A-100

Adjustable Male Branch Tees - TTP

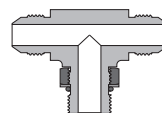

A-100

Male Run Tees - TMT

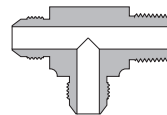

A-101

Female Branch Tees - TTF

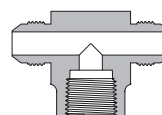

A-101

Female Run Tees - TFT

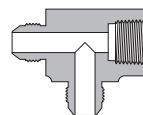

A-102

Union Tees - TTT

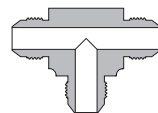

A-102

Union Crosses - C

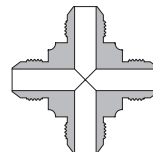

A-103

Features

- ⦿ Fittings are designed and manufactured in compliance with SAE J514
- ⦿ The hardened threads with smooth surface finish avoid galling and help to extend the fitting service life
- ⦿ Radius junction design for elbows provides smooth flow path
- ⦿ Stainless steel nut threads are silver-plated to minimize the friction with the body threads
- ⦿ Every fitting is marked with size, material and heat number
- ⦿ Fittings are easy to disconnect and retighten
- ⦿ All male threads are protected by plastic caps

Technical Data

- ⦿ Size range from 1/8" to 2" and 3 mm to 50 mm.
- ⦿ Thread Specification:

Thread Type	Reference Specification
NPT	ASME B1.20.1, SAE AS71051
Unified (SAE)	ASME B1.1, SAE J475

- ⦿ The working temperature of FITOK 37° flare tube fittings is the same as that of FITOK 6 series tube fittings.
- ⦿ Working Pressure:

Nom. SAE Dash Size	Nom. Tube O.D. Size (in.)	37° Flare St. Thread	SAE St. Thread Union and Bulkhead (psig/bar)
2	1/8	5/16-24	5000 (345)
3	3/16	3/8-24	5000 (345)
4	1/4	7/16-20	5000 (345)
5	5/16	1/2-20	5000 (345)
6	3/8	9/16-18	5000 (345)
8	1/2	3/4-16	4500 (310)
10	5/8	7/8-14	3500 (241)
12	3/4	1 1/16-12	3500 (241)
14	7/8	1 3/16-12	3000 (207)
16	1	1 5/16-12	3000 (207)
20	1 1/4	1 5/8-12	2500 (172)
24	1 1/2	1 7/8-12	2000 (138)
32	2	2 1/2-12	1500 (103)

1. Working pressures given are for fittings of stainless steel only. Contact FITOK Group or our authorized distributors for working pressure of other materials.
2. Four times safety factor applied for above working pressure.

Materials

Material	Bar Stock	Forging	Designator
316 Stainless Steel	ASTM A276 ASME SA479, EN 1.4401	ASTM A182, ASME SA182, EN 1.4401	SS
Aluminum	ASTM B211	ASTM B247	AL
Brass	ASTM B16/B453	ASTM B283	B
Carbon Steel	ASTM A108	ASTM A105	CS

Ordering Information

Add the material designator as a prefix to the basic ordering number to get the complete ordering number.

For example:

1. Male connector with 1/4" tube, 1/4 NPT thread and 316 stainless steel material, the complete ordering number is **SS-CM-AN4-NS4**.
2. Sleeve with 6 mm tube and 316 stainless steel material, the complete ordering number is **SS-SL-AN6M**.

Flaring Operation

Tube flaring is carried out in two different ways, single wall flare on thick wall tubes and double wall flare on thin wall tubes to reinforce same. Refer to the table below:

Thick Tubes

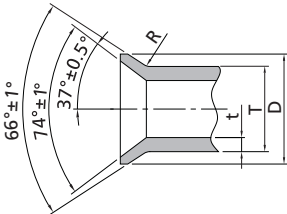

Thin Tubes

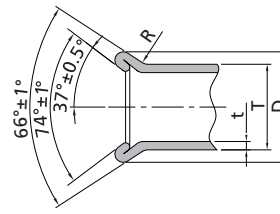

Fractional Tubing			
T-Tube O.D. in	Dimensions		
	D (mm)	t (in.)	R (mm)
1/4	8.6-9.1	0.020-0.065	0.8
5/16	10.2-10.9	0.020-0.065	0.8
3/8	11.6-12.4	0.020-0.065	1.0
1/2	16.0-16.7	0.028-0.083	1.5
5/8	19.3-20.0	0.035-0.095	1.5
3/4	23.3-24.1	0.035-0.109	2.0
7/8	26.4-27.1	0.035-0.109	2.0
1	29.7-30.4	0.035-0.120	2.3
1 1/4	37.5-38.3	0.049-0.120	2.3
1 1/2	43.2-43.9	0.049-0.120	2.8
2	59.2-59.9	0.065-0.134	2.8

Metric Tubing			
T-Tube O.D. (mm)	Dimensions		
	D (mm)	t (mm)	R (mm)
6	8.4-9.2	0.5-1.5	0.8
8	10.1-10.8	0.5-1.5	0.8
10	12.0-12.5	0.5-1.5	1.0
12	16.0-16.7	1.0-2.0	1.5
14	18.8-19.5	1.0-2.5	1.5
15	19.4-20.0	1.0-2.5	1.5
16	19.4-20.0	1.0-2.5	1.5
18	23.5-24.0	1.0-3.0	2.0
20	24.0-24.5	1.0-3.0	2.0
22	26.2-27.2	1.0-3.0	2.0
25	29.5-30.2	1.0-3.0	2.3
30	37.4-38.0	1.5-3.0	2.3
32	37.6-38.3	1.5-3.0	2.3
38	43.5-44.5	1.5-3.0	2.8
50	58.9-59.6	1.5-3.5	2.8

Installation Instructions

1. Cut the tube to the proper length.
2. Insert the tube into the nut and sleeve.
3. Form the flare to 37° dimension according to SAE J533. See flaring operation.
4. Finger-tighten the nut.
5. Tighten the nut 1/4 turn with wrench while holding steady the body of the fitting.

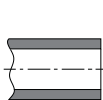

Step 1

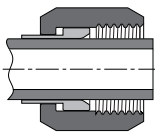

Step 2

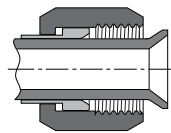

Step 3

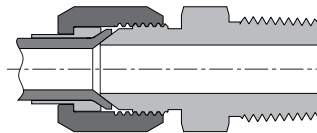

Step 4

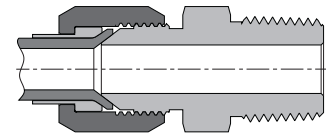

Step 5

Cautions:

- ⊙ Do not loosen or tighten fittings when system is pressurized.
- ⊙ Please use proper thread sealants on tapered pipe threads.

Dimensions

Tube cap assembly

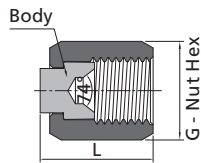

SAE 070112A					
T-Tube O.D.		Basic Ordering Number	Dimensions, in. (mm)		
in.	mm		L	G	
1/8	3	-TCA-AN2	0.60 (15.3)	0.37 (9.5)	
3/16	4	-TCA-AN3	0.66 (16.8)	0.44 (11.1)	
1/4	6	-TCA-AN4	0.67 (17.1)	0.56 (14.3)	
5/16	8	-TCA-AN5	0.77 (19.5)	0.63 (15.9)	
3/8	10	-TCA-AN6	0.81 (20.5)	0.69 (17.5)	
1/2	12	-TCA-AN8	0.94 (23.9)	0.87 (22.2)	
5/8	16	-TCA-AN10	1.07 (27.1)	1.00 (25.4)	
3/4	18	-TCA-AN12	1.24 (31.6)	1.25 (31.8)	
7/8	22	-TCA-AN14	1.26 (32.0)	1.37 (34.9)	
1	25	-TCA-AN16	1.29 (32.8)	1.50 (38.1)	
1 1/4	32	-TCA-AN20	1.39 (35.4)	2.00 (50.8)	
1 1/2	38	-TCA-AN24	1.70 (43.2)	2.25 (57.2)	
2	50	-TCA-AN32	2.07 (52.6)	2.87 (73.0)	

Nuts

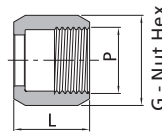

SAE 070110						
Tube O.D.		P-SAE/MS Thread Size	Basic Ordering Number	Dimensions, in. (mm)		
in.	mm			L	G	
1/8	3	5/16-24	-N-AN2	0.55 (14.0)	0.37 (9.5)	
3/16	4	3/8-24	-N-AN3	0.61 (15.5)	0.44 (11.1)	
1/4	6	7/16-20	-N-AN4	0.62 (15.8)	0.56 (14.3)	
5/16	8	1/2-20	-N-AN5	0.68 (17.3)	0.63 (15.9)	
3/8	10	9/16-18	-N-AN6	0.73 (18.5)	0.69 (17.5)	
1/2	12	3/4-16	-N-AN8	0.85 (21.6)	0.87 (22.2)	
5/8	16	7/8-14	-N-AN10	0.98 (24.9)	1.00 (25.4)	
3/4	18	1 1/16-12	-N-AN12	1.03 (26.2)	1.25 (31.8)	
7/8	22	1 3/16-12	-N-AN14	1.09 (27.7)	1.37 (34.9)	
1	25	1 5/16-12	-N-AN16	1.13 (28.7)	1.50 (38.1)	
1 1/4	32	1 5/8-12	-N-AN20	1.23 (31.2)	2.00 (50.8)	
1 1/2	38	1 7/8-12	-N-AN24	1.42 (36.1)	2.25 (57.2)	
2	50	2 1/2-12	-N-AN32	1.75 (44.5)	2.87 (73.0)	

Male Connectors

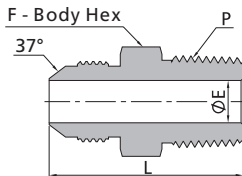

SAE 070102						
Tube O.D.		P-NPT Size	Basic Ordering Number	Dimensions, in. (mm)		
in.	mm			L	E	F
1/8	3	1/8	-CM-AN2-NS2	1.11 (28.2)	0.06 (1.6)	0.44 (11.1)
3/16	4	1/8	-CM-AN3-NS2	1.14 (29.0)	0.13 (3.2)	0.44 (11.1)
1/4	6	1/8	-CM-AN4-NS2	1.22 (31.0)	0.17 (4.4)	0.50 (12.7)
1/4	6	1/4	-CM-AN4-NS4	1.42 (36.0)	0.17 (4.4)	0.56 (14.3)
1/4	6	1/2	-CM-AN4-NS8	1.68 (42.7)	0.17 (4.4)	0.87 (22.2)
5/16	8	1/8	-CM-AN5-NS2	1.22 (31.0)	0.19 (4.8)	0.56 (14.3)
5/16	8	1/4	-CM-AN5-NS4	1.42 (36.1)	0.24 (6.0)	0.56 (14.3)
3/8	10	1/8	-CM-AN6-NS2	1.25 (31.8)	0.19 (4.8)	0.63 (15.9)
3/8	10	1/4	-CM-AN6-NS4	1.43 (36.3)	0.28 (7.1)	0.63 (15.9)
3/8	10	3/8	-CM-AN6-NS6	1.43 (36.3)	0.30 (7.5)	0.75 (19.1)
3/8	10	1/2	-CM-AN6-NS8	1.67 (42.5)	0.30 (7.5)	0.87 (22.2)
1/2	12	1/4	-CM-AN8-NS4	1.53 (38.9)	0.28 (7.1)	0.81 (20.6)
1/2	12	3/8	-CM-AN8-NS6	1.53 (38.9)	0.39 (9.9)	0.81 (20.6)
1/2	12	1/2	-CM-AN8-NS8	1.79 (45.5)	0.39 (9.9)	0.87 (22.2)
1/2	12	3/4	-CM-AN8-NS12	1.85 (47.0)	0.39 (9.9)	1.13 (28.6)
5/8	16	3/8	-CM-AN10-NS6	1.70 (43.1)	0.38 (9.6)	0.94 (23.8)
5/8	16	1/2	-CM-AN10-NS8	1.89 (48.0)	0.48 (12.3)	0.94 (23.8)
5/8	16	3/4	-CM-AN10-NS12	1.95 (49.5)	0.48 (12.3)	1.13 (28.6)
3/4	18	3/4	-CM-AN12-NS12	2.06 (52.3)	0.61 (15.5)	1.13 (28.6)
3/4	18	1	-CM-AN12-NS16	2.25 (57.1)	0.61 (15.5)	1.37 (34.9)
7/8	22	3/4	-CM-AN14-NS12	2.09 (53.1)	0.62 (15.7)	1.25 (31.8)
1	25	3/4	-CM-AN16-NS12	2.11 (53.5)	0.62 (15.7)	1.37 (34.9)
1	25	1	-CM-AN16-NS16	2.30 (58.4)	0.85 (21.5)	1.37 (34.9)
1 1/4	32	1	-CM-AN20-NS16	2.42 (61.5)	0.88 (22.4)	1.69 (42.9)
1 1/4	32	1 1/4	-CM-AN20-NS20	2.45 (62.2)	1.08 (27.5)	1.69 (42.9)
1 1/2	38	1 1/4	-CM-AN24-NS20	2.68 (68.1)	1.13 (28.6)	2.00 (50.8)
1 1/2	38	1 1/2	-CM-AN24-NS24	2.68 (68.1)	1.30 (33.0)	2.00 (50.8)
2	50	2	-CM-AN32-NS32	3.11 (79.0)	1.77 (45.0)	2.63 (66.7)

Male Connectors

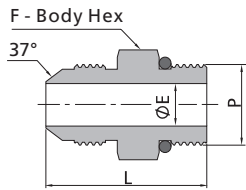

SAE 070120						
Tube O.D.		P-SAE/MS Thread Size	Basic Ordering Number	Dimensions, in. (mm)		
in.	mm			L	E	F
1/8	3	5/16-24	-CM-AN2-ST5	1.06 (26.9)	0.06 (1.6)	0.44 (11.1)
3/16	4	3/8-24	-CM-AN3-ST6	1.10 (27.9)	0.13 (3.2)	0.50 (12.7)
1/4	6	7/16-20	-CM-AN4-ST7	1.23 (31.2)	0.17 (4.4)	0.56 (14.3)
1/4	6	1/2-20	-CM-AN4-ST8	1.23 (31.2)	0.17 (4.4)	0.63 (15.9)
1/4	6	9/16-18	-CM-AN4-ST9	1.30 (33.0)	0.17 (4.4)	0.69 (17.5)
1/4	6	3/4-16	-CM-AN4-ST12	1.37 (34.8)	0.17 (4.4)	0.87 (22.2)
5/16	8	1/2-20	-CM-AN5-ST8	1.23 (31.2)	0.24 (6.0)	0.63 (15.9)
3/8	10	9/16-18	-CM-AN6-ST9	1.30 (33.0)	0.30 (7.5)	0.69 (17.5)
3/8	10	3/4-16	-CM-AN6-ST12	1.38 (35.1)	0.30 (7.5)	0.87 (22.2)
3/8	10	7/8-14	-CM-AN6-ST14	1.50 (38.1)	0.30 (7.5)	1.00 (25.4)
1/2	12	9/16-18	-CM-AN8-ST9	1.44 (36.6)	0.30 (7.5)	0.81 (20.6)
1/2	12	3/4-16	-CM-AN8-ST12	1.48 (37.6)	0.39 (9.9)	0.87 (22.2)
1/2	12	7/8-14	-CM-AN8-ST14	1.60 (40.6)	0.39 (9.9)	1.00 (25.4)
1/2	12	1 1/16-12	-CM-AN8-ST17	1.76 (44.7)	0.39 (9.9)	1.25 (31.8)
5/8	16	3/4-16	-CM-AN10-ST12	1.60 (40.6)	0.42 (10.7)	0.94 (23.8)
5/8	16	7/8-14	-CM-AN10-ST14	1.70 (43.2)	0.48 (12.3)	1.00 (25.4)
5/8	16	1 1/16-12	-CM-AN10-ST17	1.86 (47.2)	0.48 (12.3)	1.25 (31.8)
3/4	18	3/4-16	-CM-AN12-ST12	1.78 (45.2)	0.42 (10.7)	1.13 (28.6)
3/4	18	7/8-14	-CM-AN12-ST14	1.83 (46.4)	0.50 (12.7)	1.13 (28.6)
3/4	18	1 1/16-12	-CM-AN12-ST17	1.97 (50.0)	0.61 (15.5)	1.25 (31.8)
3/4	18	1 5/16-12	-CM-AN12-ST21	2.00 (50.8)	0.61 (15.5)	1.50 (38.1)
7/8	22	1 3/16-12	-CM-AN14-ST19	1.99 (50.5)	0.72 (18.3)	1.37 (34.9)
7/8	22	1 5/16-12	-CM-AN14-ST21	2.02 (51.3)	0.72 (18.3)	1.50 (38.1)
1	25	1 1/16-12	-CM-AN16-ST17	2.01 (51.1)	0.66 (16.7)	1.37 (34.9)
1	25	1 3/16-12	-CM-AN16-ST19	2.04 (51.8)	0.72 (18.3)	1.37 (34.9)
1	25	1 5/16-12	-CM-AN16-ST21	2.04 (51.8)	0.85 (21.5)	1.50 (38.1)

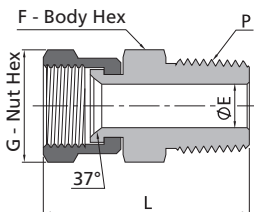

Tube O.D.		P-NPT Size	Basic Ordering Number	Dimensions, in. (mm)			
in.	mm			L	E	G	F
1/8	3	1/8	-CM-AS2-NS2	1.18 (30.0)	0.06 (1.6)	0.44 (11.1)	0.44 (11.1)
3/16	4	1/8	-CM-AS3-NS2	1.26 (32.0)	0.13 (3.2)	0.50 (12.7)	0.44 (11.1)
1/4	6	1/8	-CM-AS4-NS2	1.35 (34.2)	0.17 (4.4)	0.56 (14.3)	0.50 (12.7)
5/16	8	1/8	-CM-AS5-NS2	1.38 (35.0)	0.24 (6.0)	0.63 (15.9)	0.56 (14.3)
3/8	10	1/4	-CM-AS6-NS4	1.58 (40.2)	0.30 (7.5)	0.69 (17.5)	0.63 (15.9)
1/2	12	3/8	-CM-AS8-NS6	1.68 (42.7)	0.39 (9.9)	0.87 (22.2)	0.81 (20.6)
5/8	16	1/2	-CM-AS10-NS8	2.02 (51.3)	0.48 (12.3)	1.00 (25.4)	0.94 (23.8)
3/4	18	3/4	-CM-AS12-NS12	2.15 (54.5)	0.61 (15.5)	1.25 (31.8)	1.13 (28.6)
7/8	22	3/4	-CM-AS14-NS12	2.20 (56.0)	0.71 (18.0)	1.37 (34.9)	1.25 (31.8)
1	25	1	-CM-AS16-NS16	2.51 (63.7)	0.85 (21.5)	1.50 (38.1)	1.37 (34.9)
1 1/4	32	1 1/4	-CM-AS20-NS20	2.71 (68.9)	1.08 (27.5)	2.00 (50.8)	1.69 (42.9)
1 1/2	38	1 1/2	-CM-AS24-NS24	3.06 (77.6)	1.30 (33.0)	2.25 (57.2)	2.00 (50.8)
2	50	2	-CM-AS32-NS32	3.66 (92.9)	1.77 (45.0)	2.87 (73.0)	2.63 (66.7)

Female Connectors

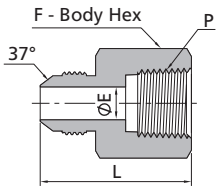

SAE 070103							
Tube O.D.		P-NPT Size	Basic Ordering Number	Dimensions, in. (mm)			F
in.	mm			L	E	F	
1/8	3	1/8	-CF-AN2-NS2	1.12 (28.4)	0.06 (1.6)	0.56 (14.3)	
3/16	4	1/8	-CF-AN3-NS2	1.13 (28.7)	0.13 (3.2)	0.56 (14.3)	
1/4	6	1/8	-CF-AN4-NS2	1.19 (30.2)	0.17 (4.4)	0.56 (14.3)	
1/4	6	1/4	-CF-AN4-NS4	1.39 (35.3)	0.17 (4.4)	0.75 (19.1)	
5/16	8	1/8	-CF-AN5-NS2	1.17 (29.7)	0.24 (6.0)	0.56 (14.3)	
5/16	8	1/4	-CF-AN5-NS4	1.39 (35.3)	0.24 (6.0)	0.75 (19.1)	
3/8	10	1/4	-CF-AN6-NS4	1.40 (35.6)	0.30 (7.5)	0.75 (19.1)	
3/8	10	3/8	-CF-AN6-NS6	1.46 (37.1)	0.30 (7.5)	0.87 (22.2)	
1/2	12	3/8	-CF-AN8-NS6	1.56 (39.6)	0.39 (9.9)	0.87 (22.2)	
1/2	12	1/2	-CF-AN8-NS8	1.80 (45.6)	0.39 (9.9)	1.13 (28.6)	
5/8	16	1/2	-CF-AN10-NS8	1.89 (48.0)	0.48 (12.3)	1.13 (28.6)	
3/4	18	1/2	-CF-AN12-NS8	2.05 (52.1)	0.61 (15.5)	1.13 (28.6)	
3/4	18	3/4	-CF-AN12-NS12	2.06 (52.3)	0.61 (15.5)	1.37 (34.9)	
7/8	22	3/4	-CF-AN14-NS12	2.06 (52.3)	0.72 (18.3)	1.37 (34.9)	
1	25	1	-CF-AN16-NS16	2.35 (59.7)	0.85 (21.5)	1.63 (41.3)	
1 1/4	32	1 1/4	-CF-AN20-NS20	2.49 (63.2)	1.08 (27.5)	2.00 (50.8)	
1 1/2	38	1 1/2	-CF-AN24-NS24	2.62 (66.5)	1.30 (33.0)	2.37 (60.3)	
2	50	2	-CF-AN32-NS32	2.97 (75.4)	1.77 (45.0)	2.87 (73.0)	

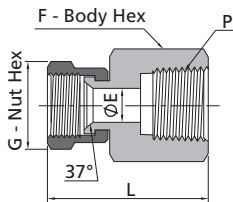

SAE 070103							
Tube O.D.		P-NPT Size	Basic Ordering Number	Dimensions, in. (mm)			
in.	mm			L	E	G	F
1/8	3	1/8	-CF-AS2-NS2	1.42 (36.1)	0.06 (1.6)	0.44 (11.1)	0.56 (14.3)
3/16	4	1/8	-CF-AS3-NS2	1.47 (37.3)	0.13 (3.2)	0.50 (12.7)	0.56 (14.3)
1/4	6	1/8	-CF-AS4-NS2	1.56 (39.7)	0.17 (4.4)	0.56 (14.3)	0.56 (14.3)
5/16	8	1/8	-CF-AS5-NS2	1.59 (40.5)	0.24 (6.0)	0.63 (15.9)	0.56 (14.3)
3/8	10	1/4	-CF-AS6-NS4	1.80 (45.8)	0.30 (7.5)	0.69 (17.5)	0.75 (19.1)
1/2	12	3/8	-CF-AS8-NS6	1.85 (47.0)	0.39 (9.9)	0.87 (22.2)	0.87 (22.2)
5/8	16	1/2	-CF-AS10-NS8	2.03 (51.6)	0.48 (12.3)	1.00 (25.4)	1.13 (28.6)
3/4	18	3/4	-CF-AS12-NS12	2.62 (66.6)	0.61 (15.5)	1.25 (31.8)	1.37 (34.9)
7/8	22	3/4	-CF-AS14-NS12	2.67 (67.8)	0.71 (18.0)	1.37 (34.9)	1.37 (34.9)
1	25	1	-CF-AS16-NS16	2.89 (73.5)	0.85 (21.5)	1.50 (38.1)	1.63 (41.3)
1 1/4	32	1 1/4	-CF-AS20-NS20	3.07 (78.1)	1.08 (27.5)	2.00 (50.8)	2.00 (50.8)
1 1/2	38	1 1/2	-CF-AS24-NS24	3.41 (86.7)	1.30 (33.0)	2.37 (60.3)	2.37 (60.3)
2	50	2	-CF-AS32-NS32	3.52 (89.3)	1.77 (45.0)	2.87 (73.0)	2.63 (66.7)

Unions

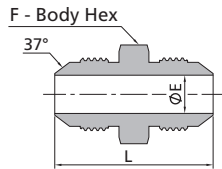

SAE 070101					
Tube O.D.		Basic Ordering Number	Dimensions, in. (mm)		
in.	mm		L	E	F
1/8	3	-U-AN2	1.17 (29.7)	0.06 (1.6)	0.44 (11.1)
3/16	4	-U-AN3	1.23 (31.2)	0.13 (3.2)	0.44 (11.1)
1/4	6	-U-AN4	1.37 (34.8)	0.17 (4.4)	0.50 (12.7)
5/16	8	-U-AN5	1.37 (34.8)	0.24 (6.0)	0.56 (14.3)
3/8	10	-U-AN6	1.41 (35.8)	0.30 (7.5)	0.63 (15.9)
1/2	12	-U-AN8	1.62 (41.1)	0.39 (9.9)	0.81 (20.6)
5/8	16	-U-AN10	1.88 (47.8)	0.48 (12.3)	0.94 (23.8)
3/4	18	-U-AN12	2.16 (54.9)	0.61 (15.5)	1.13 (28.6)
7/8	22	-U-AN14	2.21 (56.1)	0.72 (18.3)	1.25 (31.8)
1	25	-U-AN16	2.25 (57.2)	0.85 (21.5)	1.37 (34.9)
1 1/4	32	-U-AN20	2.43 (61.7)	1.08 (27.5)	1.69 (42.9)
1 1/2	38	-U-AN24	2.75 (69.8)	1.30 (33.0)	2.00 (50.8)
2	50	-U-AN32	3.40 (86.4)	1.77 (45.0)	2.63 (66.7)

Large Hex Unions

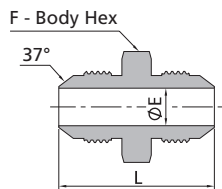

SAE 070119					
Tube O.D.		Basic Ordering Number	Dimensions, in. (mm)		
in.	mm		L	E	F
1/8	3	-HU-AN2	1.17 (29.7)	0.06 (1.6)	0.56 (14.3)
3/16	4	-HU-AN3	1.23 (31.2)	0.13 (3.2)	0.63 (15.9)
1/4	6	-HU-AN4	1.37 (34.8)	0.17 (4.4)	0.69 (17.5)
5/16	8	-HU-AN5	1.37 (34.8)	0.24 (6.0)	0.75 (19.1)
3/8	10	-HU-AN6	1.41 (35.8)	0.30 (7.5)	0.81 (20.6)
1/2	12	-HU-AN8	1.62 (41.1)	0.39 (9.9)	1.00 (25.4)
5/8	16	-HU-AN10	1.88 (47.8)	0.48 (12.3)	1.13 (28.6)
3/4	18	-HU-AN12	2.16 (54.9)	0.61 (15.5)	1.37 (34.9)
7/8	22	-HU-AN14	2.21 (56.1)	0.72 (18.3)	1.50 (38.1)
1	25	-HU-AN16	2.25 (57.2)	0.85 (21.5)	1.63 (41.3)
1 1/4	32	-HU-AN20	2.43 (61.7)	1.08 (27.5)	1.87 (47.6)
1 1/2	38	-HU-AN24	2.75 (69.8)	1.30 (33.0)	2.13 (54.0)
2	50	-HU-AN32	3.40 (86.4)	1.77 (45.0)	2.75 (69.9)

Reducing Adapters

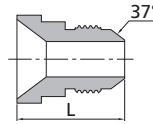

SAE 070123				
Tube O.D.		Basic Ordering Number	L	
in.-mm	in.-mm		in.(mm)	
3/8-10	1/4-6	-RA-AN6-AN4	0.97 (24.6)	
1/2-12	1/4-6	-RA-AN8-AN4	1.00 (25.4)	
1/2-12	3/8-10	-RA-AN8-AN6	1.00 (25.4)	
5/8-16	1/4-6	-RA-AN10-AN4	1.03 (26.2)	
5/8-16	3/8-10	-RA-AN10-AN6	1.03 (26.2)	
3/4-18	1/4-6	-RA-AN12-AN4	1.09 (27.7)	
3/4-18	3/8-10	-RA-AN12-AN6	1.09 (27.7)	
3/4-18	1/2-12	-RA-AN12-AN8	1.19 (30.2)	
7/8-22	3/8-10	-RA-AN14-AN6	1.13 (28.7)	
7/8-22	5/8-16	-RA-AN14-AN10	1.33 (33.7)	
1-25	1/4-6	-RA-AN16-AN4	1.22 (31.0)	
1-25	3/8-10	-RA-AN16-AN6	1.22 (31.0)	
1-25	1/2-12	-RA-AN16-AN8	1.27 (32.3)	
1-25	5/8-16	-RA-AN16-AN10	1.38 (35.1)	
1-25	3/4-18	-RA-AN16-AN12	1.47 (37.3)	
1 1/4-32	3/4-18	-RA-AN20-AN12	1.53 (38.8)	
1 1/4-32	1-25	-RA-AN20-AN16	1.59 (40.3)	
1 1/2-38	1/2-12	-RA-AN24-AN8	1.56 (39.6)	
1 1/2-38	3/4-18	-RA-AN24-AN12	1.63 (41.4)	
1 1/2-38	1-25	-RA-AN24-AN16	1.63 (41.4)	
2-50	1 1/2-38	-RA-AN32-AN24	1.91 (48.5)	

Sleeves

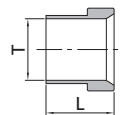

SAE 070115				
T-Tube O.D.		Basic Ordering Number		L in.(mm)
in.	mm	in.	mm	
1/8	3	-SL-AN2	-SL-AN3M	0.34 (8.6)
3/16	4	-SL-AN3	-SL-AN4M	0.34 (8.6)
1/4	6	-SL-AN4	-SL-AN6M	0.41 (10.4)
5/16	8	-SL-AN5	-SL-AN8M	0.44 (11.2)
3/8	10	-SL-AN6	-SL-AN10M	0.50 (12.7)
1/2	12	-SL-AN8	-SL-AN12M	0.56 (14.2)
5/8	16	-SL-AN10	-SL-AN16M	0.66 (16.8)
3/4	18	-SL-AN12	-SL-AN18M	0.68 (17.3)
7/8	22	-SL-AN14	-SL-AN22M	0.76 (19.3)
1	25	-SL-AN16	-SL-AN25M	0.78 (19.8)
1 1/4	32	-SL-AN20	-SL-AN32M	0.91 (23.1)
1 1/2	38	-SL-AN24	-SL-AN38M	1.12 (28.4)
2	50	-SL-AN32	-SL-AN50M	1.19 (30.2)

Bulkhead Unions

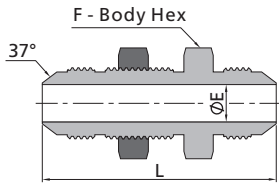

SAE 070601					
Tube O.D.		Basic Ordering Number	Dimensions, in. (mm)		
in.	mm		L	E	F
3/16	4	-BU-AN3	1.90 (48.3)	0.13 (3.2)	0.63 (15.9)
1/4	6	-BU-AN4	2.07 (52.6)	0.17 (4.4)	0.69 (17.5)
5/16	8	-BU-AN5	2.07 (52.6)	0.24 (6.0)	0.75 (19.1)
3/8	10	-BU-AN6	2.18 (55.4)	0.30 (7.5)	0.81 (20.6)
1/2	12	-BU-AN8	2.44 (62.0)	0.39 (9.9)	1.00 (25.4)
5/8	16	-BU-AN10	2.74 (69.6)	0.48 (12.3)	1.13 (28.6)
3/4	18	-BU-AN12	3.09 (78.5)	0.61 (15.5)	1.37 (34.9)
7/8	22	-BU-AN14	3.12 (79.2)	0.72 (18.3)	1.50 (38.1)
1	25	-BU-AN16	3.14 (79.8)	0.85 (21.5)	1.63 (41.3)
1 1/4	32	-BU-AN20	3.31 (84.1)	1.08 (27.5)	1.87 (47.6)
1 1/2	38	-BU-AN24	3.52 (89.4)	1.30 (33.0)	2.13 (54.0)
2	50	-BU-AN32	4.20 (106.7)	1.77 (45.0)	2.75 (69.9)

Tube Caps

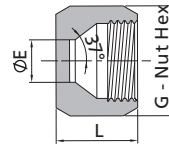

SAE 070112					
Tube O.D.		Basic Ordering Number	Dimensions, in. (mm)		
in.	mm		L	E	G
1/8	3	-TC-AN2	0.50 (12.7)	0.06 (1.6)	0.37 (9.5)
3/16	4	-TC-AN3	0.56 (14.3)	0.13 (3.2)	0.44 (11.1)
1/4	6	-TC-AN4	0.59 (15.1)	0.17 (4.4)	0.56 (14.3)
5/16	8	-TC-AN5	0.61 (15.5)	0.24 (6.0)	0.63 (15.9)
3/8	10	-TC-AN6	0.63 (15.9)	0.30 (7.5)	0.69 (17.5)
1/2	12	-TC-AN8	0.75 (19.1)	0.39 (9.9)	0.87 (22.2)
5/8	16	-TC-AN10	0.84 (21.4)	0.48 (12.3)	1.00 (25.4)
3/4	18	-TC-AN12	0.91 (23.0)	0.61 (15.5)	1.25 (31.8)
7/8	22	-TC-AN14	0.97 (24.6)	0.72 (18.3)	1.37 (34.9)
1	25	-TC-AN16	1.02 (25.8)	0.85 (21.5)	1.50 (38.1)
1 1/4	32	-TC-AN20	1.06 (27.0)	1.08 (27.5)	2.00 (50.8)
1 1/2	38	-TC-AN24	1.19 (30.2)	1.30 (33.0)	2.25 (57.2)
2	50	-TC-AN32	1.44 (36.5)	1.77 (45.0)	2.87 (73.0)

Bulkhead Lock Nuts

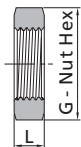

SAE 070118				
Tube O.D.		Basic Ordering Number	Dimensions, in. (mm)	
in.	mm		L	G
3/16	4	-BN-AN3	0.22 (5.6)	0.63 (15.9)
1/4	6	-BN-AN4	0.28 (7.1)	0.69 (17.5)
5/16	8	-BN-AN5	0.28 (7.1)	0.75 (19.1)
3/8	10	-BN-AN6	0.27 (6.9)	0.81 (20.6)
1/2	12	-BN-AN8	0.31 (7.9)	1.00 (25.4)
5/8	16	-BN-AN10	0.36 (9.1)	1.13 (28.6)
3/4	18	-BN-AN12	0.41 (10.4)	1.37 (34.9)
7/8	22	-BN-AN14	0.41 (10.4)	1.50 (38.1)
1	25	-BN-AN16	0.41 (10.4)	1.63 (41.3)
1 1/4	32	-BN-AN20	0.41 (10.4)	1.87 (47.6)
1 1/2	38	-BN-AN24	0.41 (10.4)	2.13 (54.0)
2	50	-BN-AN32	0.41 (10.4)	2.75 (69.9)

Tube Plugs

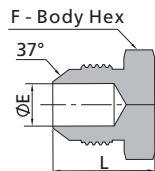

SAE 070109					
Tube O.D.		Basic Ordering Number	Dimensions, in. (mm)		
in.	mm		L	E	F
1/8	3	-TP-AN2	0.70 (17.8)	0.06 (1.6)	0.44 (11.1)
3/16	4	-TP-AN3	0.73 (18.5)	0.13 (3.2)	0.44 (11.1)
1/4	6	-TP-AN4	0.80 (20.3)	0.17 (4.4)	0.50 (12.7)
5/16	8	-TP-AN5	0.80 (20.3)	0.24 (6.0)	0.56 (14.3)
3/8	10	-TP-AN6	0.84 (21.3)	0.30 (7.5)	0.63 (15.9)
1/2	12	-TP-AN8	0.94 (23.9)	0.39 (9.9)	0.81 (20.6)
5/8	16	-TP-AN10	1.10 (27.9)	0.48 (12.3)	0.94 (23.8)
3/4	18	-TP-AN12	1.28 (32.5)	0.61 (15.5)	1.13 (28.6)
7/8	22	-TP-AN14	1.31 (33.3)	0.72 (18.3)	1.25 (31.8)
1	25	-TP-AN16	1.33 (33.8)	0.85 (21.5)	1.37 (34.9)
1 1/4	32	-TP-AN20	1.45 (36.8)	1.08 (27.5)	1.69 (42.9)
1 1/2	38	-TP-AN24	1.65 (41.9)	1.30 (33.0)	2.00 (50.8)
2	50	-TP-AN32	2.05 (52.1)	1.77 (45.0)	2.63 (66.7)

Male Elbows

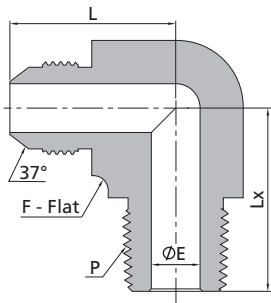

SAE 070202							
Tube O.D.		P-NPT Size	Basic Ordering Number	Dimensions, in. (mm)			
in.	mm			L	E	F	Lx
1/8	3	1/8	-LM-AN2-NS2	0.77 (19.6)	0.06 (1.6)	0.44 (11.1)	0.72 (18.3)
3/16	4	1/8	-LM-AN3-NS2	0.83 (21.1)	0.13 (3.2)	0.44 (11.1)	0.72 (18.3)
1/4	6	1/8	-LM-AN4-NS2	0.89 (22.6)	0.17 (4.4)	0.50 (12.7)	0.78 (19.8)
1/4	6	1/4	-LM-AN4-NS4	1.06 (26.9)	0.17 (4.4)	0.56 (14.3)	1.09 (27.7)
5/16	8	1/8	-LM-AN5-NS2	0.95 (24.1)	0.19 (4.8)	0.56 (14.3)	0.78 (19.8)
5/16	8	1/4	-LM-AN5-NS4	1.06 (26.9)	0.24 (6.0)	0.56 (14.3)	1.09 (27.7)
3/8	10	1/8	-LM-AN6-NS2	1.06 (26.9)	0.19 (4.8)	0.56 (14.3)	0.90 (22.8)
3/8	10	1/4	-LM-AN6-NS4	1.06 (26.9)	0.28 (7.1)	0.56 (14.3)	1.09 (27.7)
3/8	10	3/8	-LM-AN6-NS6	1.14 (29.0)	0.30 (7.5)	0.69 (17.5)	1.22 (31.0)
3/8	10	1/2	-LM-AN6-NS8	1.23 (31.2)	0.30 (7.5)	0.81 (20.6)	1.47 (37.3)
1/2	12	1/4	-LM-AN8-NS4	1.25 (31.8)	0.28 (7.1)	0.81 (20.6)	1.22 (31.0)
1/2	12	3/8	-LM-AN8-NS6	1.25 (31.8)	0.39 (9.9)	0.81 (20.6)	1.22 (31.0)
1/2	12	1/2	-LM-AN8-NS8	1.33 (33.7)	0.39 (9.9)	0.81 (20.6)	1.47 (37.3)
1/2	12	3/4	-LM-AN8-NS12	1.42 (36.0)	0.35 (9.0)	1.00 (25.4)	1.59 (40.4)
5/8	16	3/8	-LM-AN10-NS6	1.45 (36.8)	0.39 (9.9)	0.81 (20.6)	1.30 (33.0)
5/8	16	1/2	-LM-AN10-NS8	1.45 (36.8)	0.48 (12.3)	0.81 (20.6)	1.47 (37.3)
5/8	16	3/4	-LM-AN10-NS12	1.53 (38.9)	0.48 (12.3)	1.00 (25.4)	1.59 (40.4)
3/4	18	3/4	-LM-AN12-NS12	1.66 (42.2)	0.61 (15.5)	1.06 (27.0)	1.59 (40.4)
3/4	18	1	-LM-AN12-NS16	1.66 (42.2)	0.61 (15.5)	1.25 (31.8)	1.98 (50.4)
7/8	22	3/4	-LM-AN14-NS12	1.80 (45.7)	0.72 (18.3)	1.25 (31.8)	1.69 (42.9)
1	25	3/4	-LM-AN16-NS12	1.81 (46.0)	0.72 (18.3)	1.37 (34.9)	1.78 (45.2)
1	25	1	-LM-AN16-NS16	1.81 (46.0)	0.85 (21.5)	1.37 (34.9)	1.97 (50.0)
1 1/4	32	1	-LM-AN20-NS16	2.06 (52.3)	0.94 (23.8)	1.69 (42.9)	2.35 (59.6)
1 1/4	32	1 1/4	-LM-AN20-NS20	2.06 (52.3)	1.08 (27.5)	1.69 (42.9)	2.38 (60.5)
1 1/2	38	1 1/2	-LM-AN24-NS24	2.33 (59.2)	1.30 (33.0)	2.00 (50.8)	2.64 (67.1)
2	50	2	-LM-AN32-NS32	3.06 (77.7)	1.77 (45.0)	2.50 (63.5)	3.00 (76.2)

Adjustable Male Elbows

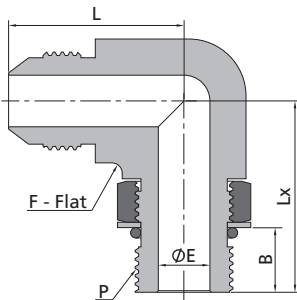

SAE 070220								
Tube O.D.		P-SAE/MS Thread Size	Basic Ordering Number	Dimensions, in. (mm)				
in.	mm			L	E	F	Lx	B
1/8	3	5/16-24	-LP-AN2-ST5	0.77 (19.6)	0.06 (1.6)	0.44 (11.1)	0.94 (23.9)	0.33 (8.4)
3/16	4	3/8-24	-LP-AN3-ST6	0.83 (21.1)	0.13 (3.2)	0.44 (11.1)	0.94 (23.9)	0.33 (8.4)
1/4	6	7/16-20	-LP-AN4-ST7	0.89 (22.6)	0.17 (4.4)	0.50 (12.7)	1.03 (26.2)	0.39 (9.8)
5/16	8	1/2-20	-LP-AN5-ST8	0.95 (24.1)	0.24 (6.0)	0.56 (14.3)	1.13 (28.7)	0.39 (9.8)
3/8	10	9/16-18	-LP-AN6-ST9	1.06 (26.9)	0.30 (7.5)	0.63 (15.9)	1.25 (31.8)	0.43 (11.0)
1/2	12	3/4-16	-LP-AN8-ST12	1.25 (31.8)	0.39 (9.9)	0.81 (20.6)	1.45 (36.8)	0.49 (12.5)
5/8	16	7/8-14	-LP-AN10-ST14	1.45 (36.8)	0.48 (12.3)	0.94 (23.8)	1.70 (43.2)	0.56 (14.2)
3/4	18	1 1/16-12	-LP-AN12-ST17	1.66 (42.2)	0.61 (15.5)	1.25 (31.8)	1.94 (49.3)	0.65 (16.5)
7/8	22	1 3/16-12	-LP-AN14-ST19	1.80 (45.7)	0.72 (18.3)	1.25 (31.8)	2.00 (50.8)	0.65 (16.5)
1	25	1 5/16-12	-LP-AN16-ST21	1.81 (46.0)	0.85 (21.5)	1.37 (34.9)	2.05 (52.1)	0.65 (16.5)
1 1/4	32	1 5/8-12	-LP-AN20-ST26	2.06 (52.3)	1.08 (27.5)	1.69 (42.9)	2.25 (57.2)	0.65 (16.5)
1 1/2	38	1 7/8-12	-LP-AN24-ST30	2.33 (59.2)	1.30 (33.0)	2.00 (50.8)	2.39 (60.7)	0.65 (16.5)
2	50	2 1/2-12	-LP-AN32-ST40	3.06 (77.7)	1.77 (45.0)	2.50 (63.5)	2.89 (73.4)	0.65 (16.5)

45° Male Elbows

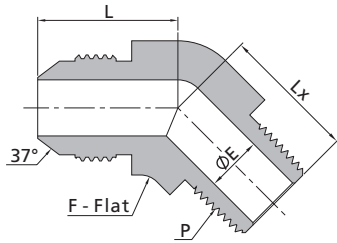

SAE 070302							
Tube O.D.		P-NPT Size	Basic Ordering Number	Dimensions, in. (mm)			
in.	mm			L	E	F	Lx
1/8	3	1/8	-VM-AN2-NS2	0.69 (17.5)	0.06 (1.6)	0.44 (11.1)	0.52 (13.2)
3/16	4	1/8	-VM-AN3-NS2	0.69 (17.5)	0.13 (3.2)	0.44 (11.1)	0.52 (13.2)
1/4	6	1/8	-VM-AN4-NS2	0.72 (18.3)	0.17 (4.4)	0.50 (12.7)	0.64 (16.3)
5/16	8	1/8	-VM-AN5-NS2	0.77 (19.6)	0.19 (4.8)	0.56 (14.3)	0.64 (16.3)
3/8	10	1/4	-VM-AN6-NS4	0.83 (21.1)	0.28 (7.1)	0.56 (14.3)	0.86 (21.8)
1/2	12	3/8	-VM-AN8-NS6	0.98 (24.9)	0.39 (9.9)	0.69 (17.5)	0.95 (24.1)
5/8	16	1/2	-VM-AN10-NS8	1.11 (28.2)	0.48 (12.3)	0.81 (20.6)	1.17 (29.7)
3/4	18	3/4	-VM-AN12-NS12	1.28 (32.5)	0.61 (15.5)	1.06 (27.0)	1.20 (30.5)
7/8	22	3/4	-VM-AN14-NS12	1.45 (36.8)	0.72 (18.3)	1.25 (31.8)	1.30 (33.0)
1	25	1	-VM-AN16-NS16	1.47 (37.3)	0.85 (21.5)	1.37 (34.9)	1.48 (37.6)
1 1/4	32	1 1/4	-VM-AN20-NS20	1.59 (40.4)	1.08 (27.5)	1.69 (42.9)	1.67 (42.4)
1 1/2	38	1 1/2	-VM-AN24-NS24	1.78 (45.2)	1.30 (33.0)	2.00 (50.8)	1.77 (45.0)
2	50	2	-VM-AN32-NS32	2.22 (56.4)	1.77 (45.0)	2.50 (63.5)	2.11 (53.6)

Female Elbows

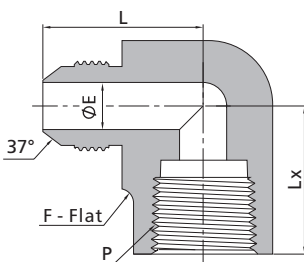

SAE 070203							
Tube O.D.		P-NPT Size	Basic Ordering Number	Dimensions, in. (mm)			
in.	mm			L	E	F	Lx
1/8	3	1/8	-LF-AN2-NS2	1.00 (25.4)	0.06 (1.6)	0.56 (14.3)	0.66 (16.8)
3/16	4	1/8	-LF-AN3-NS2	1.03 (26.2)	0.13 (3.2)	0.56 (14.3)	0.66 (16.8)
1/4	6	1/8	-LF-AN4-NS2	1.08 (27.4)	0.17 (4.4)	0.56 (14.3)	0.66 (16.8)
1/4	6	1/4	-LF-AN4-NS4	1.22 (30.9)	0.17 (4.4)	0.81 (20.6)	0.88 (22.4)
5/16	8	1/8	-LF-AN5-NS2	1.08 (27.4)	0.24 (6.0)	0.56 (14.3)	0.66 (16.8)
5/16	8	1/4	-LF-AN5-NS4	1.22 (30.9)	0.24 (6.0)	0.81 (20.6)	0.88 (22.4)
3/8	10	1/8	-LF-AN6-NS2	1.06 (26.9)	0.30 (7.5)	0.63 (15.9)	0.66 (16.8)
3/8	10	1/4	-LF-AN6-NS4	1.23 (31.2)	0.30 (7.5)	0.81 (20.6)	0.88 (22.4)
3/8	10	3/8	-LF-AN6-NS6	1.31 (33.2)	0.30 (7.5)	0.94 (23.8)	1.02 (25.9)
1/2	12	1/4	-LF-AN8-NS4	1.24 (31.6)	0.39 (9.9)	0.81 (20.6)	0.88 (22.4)
1/2	12	3/8	-LF-AN8-NS6	1.42 (36.1)	0.39 (9.9)	0.94 (23.8)	1.02 (25.9)
1/2	12	1/2	-LF-AN8-NS8	1.42 (36.1)	0.39 (9.9)	1.06 (27.0)	1.23 (31.2)
5/8	16	1/2	-LF-AN10-NS8	1.64 (41.7)	0.48 (12.3)	1.06 (27.0)	1.23 (31.2)
3/4	18	1/2	-LF-AN12-NS8	1.66 (42.1)	0.61 (15.5)	1.25 (31.8)	1.23 (31.2)
3/4	18	3/4	-LF-AN12-NS12	1.89 (48.0)	0.61 (15.5)	1.37 (34.9)	1.36 (34.5)
7/8	22	3/4	-LF-AN14-NS12	1.86 (47.2)	0.72 (18.3)	1.37 (34.9)	1.42 (36.1)
1	25	1	-LF-AN16-NS16	2.17 (55.1)	0.85 (21.5)	1.69 (42.9)	1.62 (41.1)
1 1/4	32	1 1/4	-LF-AN20-NS20	2.33 (59.2)	1.08 (27.5)	2.00 (50.8)	1.70 (43.2)
1 1/2	38	1 1/2	-LF-AN24-NS24	2.89 (73.4)	1.30 (33.0)	2.50 (63.5)	2.08 (52.8)
2	50	2	-LF-AN32-NS32	3.30 (83.8)	1.77 (45.0)	2.50 (63.5)	2.39 (60.7)

Union Elbows

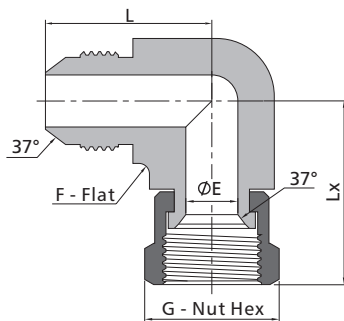
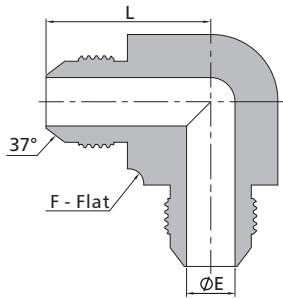

SAE 070201						
Tube O.D.		Basic Ordering Number	Dimensions, in. (mm)			
in.	mm		L	E	F	
1/8	3	-LU-AN2	0.77 (19.6)	0.06 (1.6)	0.44 (11.1)	
3/16	4	-LU-AN3	0.83 (21.1)	0.13 (3.2)	0.44 (11.1)	
1/4	6	-LU-AN4	0.89 (22.6)	0.17 (4.4)	0.50 (12.7)	
5/16	8	-LU-AN5	0.95 (24.1)	0.24 (6.0)	0.56 (14.3)	
3/8	10	-LU-AN6	1.06 (26.9)	0.30 (7.5)	0.56 (14.3)	
1/2	12	-LU-AN8	1.25 (31.8)	0.39 (9.9)	0.81 (20.6)	
5/8	16	-LU-AN10	1.45 (36.8)	0.48 (12.3)	0.81 (20.6)	
3/4	18	-LU-AN12	1.66 (42.2)	0.61 (15.5)	1.06 (27.0)	
7/8	22	-LU-AN14	1.80 (45.7)	0.72 (18.3)	1.25 (31.8)	
1	25	-LU-AN16	1.81 (46.0)	0.85 (21.5)	1.37 (34.9)	
1 1/4	32	-LU-AN20	2.06 (52.3)	1.08 (27.5)	1.69 (42.9)	
1 1/2	38	-LU-AN24	2.33 (59.2)	1.30 (33.0)	2.00 (50.8)	
2	50	-LU-AN32	3.06 (77.7)	1.77 (45.0)	2.50 (63.5)	

SAE 070221								
Tube O.D.		Basic Ordering Number	Dimensions, in. (mm)					
in.	mm		L	E	F	Lx	G	
1/8	3	-LU-AN2-AS2	0.77 (19.6)	0.06 (1.6)	0.44 (11.1)	0.97 (24.6)	0.44 (11.1)	
3/16	4	-LU-AN3-AS3	0.83 (21.1)	0.13 (3.2)	0.44 (11.1)	1.00 (25.4)	0.50 (12.7)	
1/4	6	-LU-AN4-AS4	0.89 (22.6)	0.17 (4.4)	0.50 (12.7)	1.00 (25.4)	0.56 (14.3)	
5/16	8	-LU-AN5-AS5	0.95 (24.1)	0.24 (6.0)	0.56 (14.3)	1.06 (26.9)	0.63 (15.9)	
3/8	10	-LU-AN6-AS6	1.06 (26.9)	0.30 (7.5)	0.56 (14.3)	1.25 (31.8)	0.69 (17.5)	
1/2	12	-LU-AN8-AS8	1.25 (31.8)	0.39 (9.9)	0.81 (20.6)	1.38 (35.1)	0.87 (22.2)	
5/8	16	-LU-AN10-AS10	1.45 (36.8)	0.48 (12.3)	0.81 (20.6)	1.62 (41.1)	1.00 (25.4)	
3/4	18	-LU-AN12-AS12	1.66 (42.2)	0.61 (15.5)	1.06 (27.0)	1.75 (44.4)	1.25 (31.8)	
7/8	22	-LU-AN14-AS14	1.80 (45.7)	0.72 (18.3)	1.25 (31.8)	1.78 (45.2)	1.37 (34.9)	
1	25	-LU-AN16-AS16	1.81 (46.0)	0.85 (21.5)	1.37 (34.9)	2.00 (50.8)	1.50 (38.1)	
1 1/4	32	-LU-AN20-AS20	2.06 (52.3)	1.08 (27.5)	1.69 (42.9)	2.31 (58.7)	2.00 (50.8)	
1 1/2	38	-LU-AN24-AS24	2.33 (59.2)	1.30 (33.0)	2.00 (50.8)	2.59 (65.8)	2.37 (60.3)	
2	50	-LU-AN32-AS32	3.06 (77.7)	1.77 (45.0)	2.50 (63.5)	3.38 (85.9)	2.87 (73.0)	

Male Branch Tees

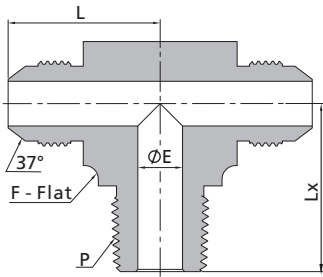

SAE 070425							
Tube O.D.		P-NPT Size	Basic Ordering Number	Dimensions, in. (mm)			
in.	mm			L	E	F	Lx
1/8	3	1/8	-TTM-AN2-NS2	0.77 (19.6)	0.06 (1.6)	0.44 (11.1)	0.72 (18.3)
3/16	4	1/8	-TTM-AN3-NS2	0.83 (21.1)	0.13 (3.2)	0.44 (11.1)	0.72 (18.3)
1/4	6	1/8	-TTM-AN4-NS2	0.89 (22.6)	0.17 (4.4)	0.50 (12.7)	0.78 (19.8)
1/4	6	1/4	-TTM-AN4-NS4	1.06 (26.9)	0.17 (4.4)	0.56 (14.3)	1.09 (27.7)
5/16	8	1/8	-TTM-AN5-NS2	0.95 (24.1)	0.19 (4.8)	0.56 (14.3)	0.78 (19.8)
5/16	8	1/4	-TTM-AN5-NS4	1.06 (26.9)	0.24 (6.0)	0.56 (14.3)	1.09 (27.7)
3/8	10	1/8	-TTM-AN6-NS2	1.06 (26.9)	0.19 (4.8)	0.56 (14.3)	0.90 (22.8)
3/8	10	1/4	-TTM-AN6-NS4	1.06 (26.9)	0.28 (7.1)	0.56 (14.3)	1.09 (27.7)
3/8	10	3/8	-TTM-AN6-NS6	1.14 (29.0)	0.30 (7.5)	0.69 (17.5)	1.22 (31.0)
3/8	10	1/2	-TTM-AN6-NS8	1.23 (31.2)	0.30 (7.5)	0.81 (20.6)	1.47 (37.3)
1/2	12	1/4	-TTM-AN8-NS4	1.25 (31.8)	0.28 (7.1)	0.81 (20.6)	1.22 (31.0)
1/2	12	3/8	-TTM-AN8-NS6	1.25 (31.8)	0.39 (9.9)	0.81 (20.6)	1.22 (31.0)
1/2	12	1/2	-TTM-AN8-NS8	1.33 (33.7)	0.39 (9.9)	0.81 (20.6)	1.47 (37.3)
1/2	12	3/4	-TTM-AN8-NS12	1.42 (36.0)	0.39 (9.9)	1.00 (25.4)	1.59 (40.4)
5/8	16	3/8	-TTM-AN10-NS6	1.45 (36.8)	0.39 (9.9)	0.81 (20.6)	1.30 (33.0)
5/8	16	1/2	-TTM-AN10-NS8	1.45 (36.8)	0.48 (12.3)	0.81 (20.6)	1.47 (37.3)
5/8	16	3/4	-TTM-AN10-NS12	1.53 (38.9)	0.48 (12.3)	1.00 (25.4)	1.59 (40.4)
3/4	18	3/4	-TTM-AN12-NS12	1.66 (42.2)	0.61 (15.5)	1.06 (27.0)	1.59 (40.4)
3/4	18	1	-TTM-AN12-NS16	1.66 (42.2)	0.61 (15.5)	1.25 (31.8)	1.98 (50.4)
7/8	22	3/4	-TTM-AN14-NS12	1.80 (45.7)	0.72 (18.3)	1.25 (31.8)	1.69 (42.9)
1	25	3/4	-TTM-AN16-NS12	1.81 (46.0)	0.72 (18.3)	1.37 (34.9)	1.78 (45.2)
1	25	1	-TTM-AN16-NS16	1.81 (46.0)	0.85 (21.5)	1.37 (34.9)	1.97 (50.0)
1 1/4	32	1	-TTM-AN20-NS16	2.06 (52.3)	0.94 (23.8)	1.69 (42.9)	2.35 (59.6)
1 1/4	32	1 1/4	-TTM-AN20-NS20	2.06 (52.3)	1.08 (27.5)	1.69 (42.9)	2.38 (60.5)
1 1/2	38	1 1/2	-TTM-AN24-NS24	2.33 (59.2)	1.30 (33.0)	2.00 (50.8)	2.64 (67.1)
2	50	2	-TTM-AN32-NS32	3.06 (77.7)	1.77 (45.0)	2.50 (63.5)	3.00 (76.2)

Adjustable Male Branch Tees

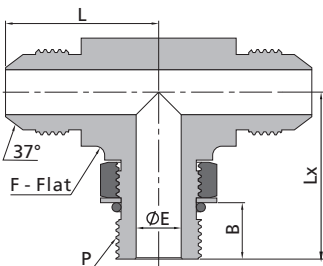

SAE 070429								
Tube O.D.		P-SAE/MS Thread Size	Basic Ordering Number	Dimensions, in. (mm)				
in.	mm			L	E	F	Lx	B
1/8	3	5/16-24	-TTP-AN2-ST5	0.77 (19.6)	0.06 (1.6)	0.44 (11.1)	0.94 (23.9)	0.33 (8.4)
3/16	4	3/8-24	-TTP-AN3-ST6	0.83 (21.1)	0.13 (3.2)	0.44 (11.1)	0.94 (23.9)	0.33 (8.4)
1/4	6	7/16-20	-TTP-AN4-ST7	0.89 (22.6)	0.17 (4.4)	0.50 (12.7)	1.03 (26.2)	0.39 (9.8)
5/16	8	1/2-20	-TTP-AN5-ST8	0.95 (24.1)	0.24 (6.0)	0.56 (14.3)	1.13 (28.7)	0.39 (9.8)
3/8	10	9/16-18	-TTP-AN6-ST9	1.06 (26.9)	0.30 (7.5)	0.63 (15.9)	1.25 (31.8)	0.43 (11.0)
1/2	12	3/4-16	-TTP-AN8-ST12	1.25 (31.8)	0.39 (9.9)	0.81 (20.6)	1.45 (36.8)	0.49 (12.5)
5/8	16	7/8-14	-TTP-AN10-ST14	1.45 (36.8)	0.48 (12.3)	0.94 (23.8)	1.70 (43.2)	0.56 (14.2)
3/4	18	1 1/16-12	-TTP-AN12-ST17	1.66 (42.2)	0.61 (15.5)	1.25 (31.8)	1.94 (49.3)	0.65 (16.5)
7/8	22	1 3/16-12	-TTP-AN14-ST19	1.80 (45.7)	0.72 (18.3)	1.25 (31.8)	2.00 (50.8)	0.65 (16.5)
1	25	1 5/16-12	-TTP-AN16-ST21	1.81 (46.0)	0.85 (21.5)	1.37 (34.9)	2.05 (52.1)	0.65 (16.5)
1 1/4	32	1 5/8-12	-TTP-AN20-ST26	2.06 (52.3)	1.08 (27.5)	1.69 (42.9)	2.25 (57.2)	0.65 (16.5)
1 1/2	38	1 7/8-12	-TTP-AN24-ST30	2.33 (59.2)	1.30 (33.0)	2.00 (50.8)	2.39 (60.7)	0.65 (16.5)
2	50	2 1/2-12	-TTP-AN32-ST40	3.06 (77.7)	1.77 (45.0)	2.50 (63.5)	2.89 (73.4)	0.65 (16.5)

Male Run Tees

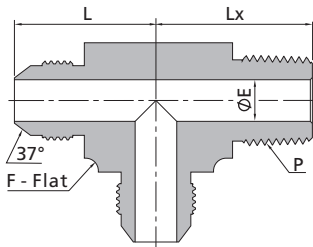

SAE 070424							
Tube O.D.		P-NPT Size	Basic Ordering Number	Dimensions, in. (mm)			
in.	mm			L	E	F	Lx
1/8	3	1/8	-TMT-AN2-NS2	0.77 (19.6)	0.06 (1.6)	0.44 (11.1)	0.72 (18.3)
3/16	4	1/8	-TMT-AN3-NS2	0.83 (21.1)	0.13 (3.2)	0.44 (11.1)	0.72 (18.3)
1/4	6	1/8	-TMT-AN4-NS2	0.89 (22.6)	0.17 (4.4)	0.50 (12.7)	0.78 (19.8)
1/4	6	1/4	-TMT-AN4-NS4	1.06 (26.9)	0.17 (4.4)	0.56 (14.3)	1.09 (27.7)
5/16	8	1/8	-TMT-AN5-NS2	0.95 (24.1)	0.19 (4.8)	0.56 (14.3)	0.78 (19.8)
5/16	8	1/4	-TMT-AN5-NS4	1.06 (26.9)	0.24 (6.0)	0.56 (14.3)	1.09 (27.7)
3/8	10	1/8	-TMT-AN6-NS2	1.06 (26.9)	0.19 (4.8)	0.56 (14.3)	0.90 (22.8)
3/8	10	1/4	-TMT-AN6-NS4	1.06 (26.9)	0.28 (7.1)	0.56 (14.3)	1.09 (27.7)
3/8	10	3/8	-TMT-AN6-NS6	1.14 (29.0)	0.30 (7.5)	0.69 (17.5)	1.22 (31.0)
3/8	10	1/2	-TMT-AN6-NS8	1.23 (31.2)	0.30 (7.5)	0.81 (20.6)	1.47 (37.3)
1/2	12	1/4	-TMT-AN8-NS4	1.25 (31.8)	0.28 (7.1)	0.81 (20.6)	1.22 (31.0)
1/2	12	3/8	-TMT-AN8-NS6	1.25 (31.8)	0.39 (9.9)	0.81 (20.6)	1.22 (31.0)
1/2	12	1/2	-TMT-AN8-NS8	1.33 (33.7)	0.39 (9.9)	0.81 (20.6)	1.47 (37.3)
1/2	12	3/4	-TMT-AN8-NS12	1.42 (36.0)	0.39 (9.9)	1.00 (25.4)	1.59 (40.4)
5/8	16	3/8	-TMT-AN10-NS6	1.45 (36.8)	0.39 (9.9)	0.81 (20.6)	1.30 (33.0)
5/8	16	1/2	-TMT-AN10-NS8	1.45 (36.8)	0.48 (12.3)	0.81 (20.6)	1.47 (37.3)
5/8	16	3/4	-TMT-AN10-NS12	1.53 (38.9)	0.48 (12.3)	1.00 (25.4)	1.59 (40.4)
3/4	18	3/4	-TMT-AN12-NS12	1.66 (42.2)	0.61 (15.5)	1.06 (27.0)	1.59 (40.4)
3/4	18	1	-TMT-AN12-NS16	1.66 (42.2)	0.61 (15.5)	1.25 (31.8)	1.98 (50.4)
7/8	22	3/4	-TMT-AN14-NS12	1.80 (45.7)	0.72 (18.3)	1.25 (31.8)	1.69 (42.9)
1	25	3/4	-TMT-AN16-NS12	1.81 (46.0)	0.72 (18.3)	1.37 (34.9)	1.78 (45.2)
1	25	1	-TMT-AN16-NS16	1.81 (46.0)	0.85 (21.5)	1.37 (34.9)	1.97 (50.0)
1 1/4	32	1	-TMT-AN20-NS16	2.06 (52.3)	0.94 (23.8)	1.69 (42.9)	2.35 (59.6)
1 1/4	32	1 1/4	-TMT-AN20-NS20	2.06 (52.3)	1.08 (27.5)	1.69 (42.9)	2.38 (60.5)
1 1/2	38	1 1/2	-TMT-AN24-NS24	2.33 (59.2)	1.30 (33.0)	2.00 (50.8)	2.64 (67.1)
2	50	2	-TMT-AN32-NS32	3.06 (77.7)	1.77 (45.0)	2.50 (63.5)	3.00 (76.2)

Female Branch Tees

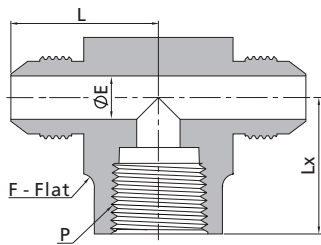

SAE 070427							
Tube O.D.		P-NPT Size	Basic Ordering Number	Dimensions, in. (mm)			
in.	mm			L	E	F	Lx
1/8	3	1/8	-TTF-AN2-NS2	1.00 (25.4)	0.06 (1.6)	0.56 (14.3)	0.66 (16.8)
3/16	4	1/8	-TTF-AN3-NS2	1.03 (26.2)	0.13 (3.2)	0.56 (14.3)	0.66 (16.8)
1/4	6	1/8	-TTF-AN4-NS2	1.08 (27.4)	0.17 (4.4)	0.56 (14.3)	0.66 (16.8)
1/4	6	1/4	-TTF-AN4-NS4	1.22 (30.9)	0.17 (4.4)	0.81 (20.6)	0.88 (22.4)
5/16	8	1/8	-TTF-AN5-NS2	1.08 (27.4)	0.24 (6.0)	0.56 (14.3)	0.66 (16.8)
5/16	8	1/4	-TTF-AN5-NS4	1.22 (30.9)	0.24 (6.0)	0.81 (20.6)	0.88 (22.4)
3/8	10	1/8	-TTF-AN6-NS2	1.06 (26.9)	0.30 (7.5)	0.63 (15.9)	0.66 (16.8)
3/8	10	1/4	-TTF-AN6-NS4	1.23 (31.2)	0.30 (7.5)	0.81 (20.6)	0.88 (22.4)
3/8	10	3/8	-TTF-AN6-NS6	1.31 (33.2)	0.30 (7.5)	0.94 (23.8)	1.02 (25.9)
1/2	12	1/4	-TTF-AN8-NS4	1.24 (31.6)	0.39 (9.9)	0.81 (20.6)	0.88 (22.4)
1/2	12	3/8	-TTF-AN8-NS6	1.42 (36.1)	0.39 (9.9)	0.94 (23.8)	1.02 (25.9)
1/2	12	1/2	-TTF-AN8-NS8	1.42 (36.1)	0.39 (9.9)	1.06 (27.0)	1.23 (31.2)
5/8	16	1/2	-TTF-AN10-NS8	1.64 (41.7)	0.48 (12.3)	1.06 (27.0)	1.23 (31.2)
3/4	18	1/2	-TTF-AN12-NS8	1.66 (42.1)	0.61 (15.5)	1.25 (31.8)	1.23 (31.2)
3/4	18	3/4	-TTF-AN12-NS12	1.89 (48.0)	0.61 (15.5)	1.37 (34.9)	1.36 (34.5)
7/8	22	3/4	-TTF-AN14-NS12	1.86 (47.2)	0.72 (18.3)	1.37 (34.9)	1.42 (36.1)
1	25	1	-TTF-AN16-NS16	2.17 (55.1)	0.85 (21.5)	1.69 (42.9)	1.62 (41.1)
1 1/4	32	1 1/4	-TTF-AN20-NS20	2.33 (59.2)	1.08 (27.5)	2.00 (50.8)	1.70 (43.2)
1 1/2	38	1 1/2	-TTF-AN24-NS24	2.89 (73.4)	1.30 (33.0)	2.50 (63.5)	2.08 (52.8)
2	50	2	-TTF-AN32-NS32	3.30 (83.8)	1.77 (45.0)	2.50 (63.5)	2.39 (60.7)

Tube Fittings

Female Run Tees

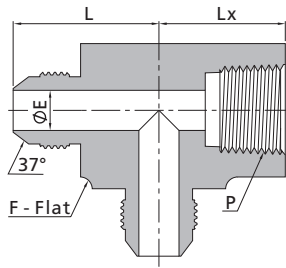

Tube Fittings

SAE 070426							
Tube O.D.		P-NPT Size	Basic Ordering Number	Dimensions, in. (mm)			
in.	mm			L	E	F	Lx
1/8	3	1/8	-TFT-AN2-NS2	1.00 (25.4)	0.06 (1.6)	0.56 (14.3)	0.66 (16.8)
3/16	4	1/8	-TFT-AN3-NS2	1.03 (26.2)	0.13 (3.2)	0.56 (14.3)	0.66 (16.8)
1/4	6	1/8	-TFT-AN4-NS2	1.08 (27.4)	0.17 (4.4)	0.56 (14.3)	0.66 (16.8)
1/4	6	1/4	-TFT-AN4-NS4	1.22 (30.9)	0.17 (4.4)	0.81 (20.6)	0.88 (22.4)
5/16	8	1/8	-TFT-AN5-NS2	1.08 (27.4)	0.24 (6.0)	0.56 (14.3)	0.66 (16.8)
5/16	8	1/4	-TFT-AN5-NS4	1.22 (30.9)	0.24 (6.0)	0.81 (20.6)	0.88 (22.4)
3/8	10	1/8	-TFT-AN6-NS2	1.06 (26.9)	0.30 (7.5)	0.63 (15.9)	0.66 (16.8)
3/8	10	1/4	-TFT-AN6-NS4	1.23 (31.2)	0.30 (7.5)	0.81 (20.6)	0.88 (22.4)
3/8	10	3/8	-TFT-AN6-NS6	1.31 (33.2)	0.30 (7.5)	0.94 (23.8)	1.02 (25.9)
1/2	12	1/4	-TFT-AN8-NS4	1.24 (31.6)	0.39 (9.9)	0.81 (20.6)	0.88 (22.4)
1/2	12	3/8	-TFT-AN8-NS6	1.42 (36.1)	0.39 (9.9)	0.94 (23.8)	1.02 (25.9)
1/2	12	1/2	-TFT-AN8-NS8	1.42 (36.1)	0.39 (9.9)	1.06 (27.0)	1.23 (31.2)
5/8	16	1/2	-TFT-AN10-NS8	1.64 (41.7)	0.48 (12.3)	1.06 (27.0)	1.23 (31.2)
3/4	18	1/2	-TFT-AN12-NS8	1.66 (42.1)	0.61 (15.5)	1.25 (31.8)	1.23 (31.2)
3/4	18	3/4	-TFT-AN12-NS12	1.89 (48.0)	0.61 (15.5)	1.37 (34.9)	1.36 (34.5)
7/8	22	3/4	-TFT-AN14-NS12	1.86 (47.2)	0.72 (18.3)	1.37 (34.9)	1.42 (36.1)
1	25	1	-TFT-AN16-NS16	2.17 (55.1)	0.85 (21.5)	1.69 (42.9)	1.62 (41.1)
1 1/4	32	1 1/4	-TFT-AN20-NS20	2.33 (59.2)	1.08 (27.5)	2.00 (50.8)	1.70 (43.2)
1 1/2	38	1 1/2	-TFT-AN24-NS24	2.89 (73.4)	1.30 (33.0)	2.50 (63.5)	2.08 (52.8)
2	50	2	-TFT-AN32-NS32	3.30 (83.8)	1.77 (45.0)	2.50 (63.5)	2.39 (60.7)

Union Tees

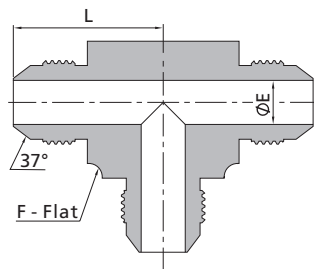

SAE 070401					
Tube O.D.		Basic Ordering Number	Dimensions, in. (mm)		
in.	mm		L	E	F
1/8	3	-TTT-AN2	0.77 (19.6)	0.06 (1.6)	0.44 (11.1)
3/16	4	-TTT-AN3	0.83 (21.1)	0.13 (3.2)	0.44 (11.1)
1/4	6	-TTT-AN4	0.89 (22.6)	0.17 (4.4)	0.50 (12.7)
5/16	8	-TTT-AN5	0.95 (24.1)	0.24 (6.0)	0.56 (14.3)
3/8	10	-TTT-AN6	1.06 (26.9)	0.30 (7.5)	0.56 (14.3)
1/2	12	-TTT-AN8	1.25 (31.8)	0.39 (9.9)	0.81 (20.6)
5/8	16	-TTT-AN10	1.45 (36.8)	0.48 (12.3)	0.81 (20.6)
3/4	18	-TTT-AN12	1.66 (42.2)	0.61 (15.5)	1.06 (27.0)
7/8	22	-TTT-AN14	1.80 (45.7)	0.72 (18.3)	1.25 (31.8)
1	25	-TTT-AN16	1.81 (46.0)	0.85 (21.5)	1.37 (34.9)
1 1/4	32	-TTT-AN20	2.06 (52.3)	1.08 (27.5)	1.69 (42.9)
1 1/2	38	-TTT-AN24	2.33 (59.2)	1.30 (33.0)	2.00 (50.8)
2	50	-TTT-AN32	3.06 (77.7)	1.77 (45.0)	2.50 (63.5)

Union Tees

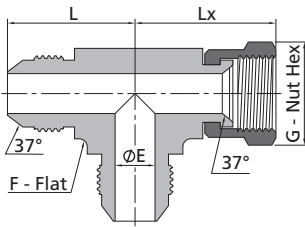

SAE 070432								
Tube O.D.		Basic Ordering Number	Dimensions, in. (mm)					
in.	mm		L	E	F	Lx	G	
1/8	3	-TTT-AN2-AS2-AN2	0.77 (19.6)	0.06 (1.6)	0.44 (11.1)	0.97 (24.6)	0.44 (11.1)	
3/16	4	-TTT-AN3-AS3-AN3	0.83 (21.1)	0.13 (3.2)	0.44 (11.1)	1.00 (25.4)	0.50 (12.7)	
1/4	6	-TTT-AN4-AS4-AN4	0.89 (22.6)	0.17 (4.4)	0.50 (12.7)	1.00 (25.4)	0.56 (14.3)	
5/16	8	-TTT-AN5-AS5-AN5	0.95 (24.1)	0.24 (6.0)	0.56 (14.3)	1.06 (26.9)	0.63 (15.9)	
3/8	10	-TTT-AN6-AS6-AN6	1.06 (26.9)	0.30 (7.5)	0.56 (14.3)	1.25 (31.8)	0.69 (17.5)	
1/2	12	-TTT-AN8-AS8-AN8	1.25 (31.8)	0.39 (9.9)	0.81 (20.6)	1.38 (35.1)	0.87 (22.2)	
5/8	16	-TTT-AN10-AS10-AN10	1.45 (36.8)	0.48 (12.3)	0.81 (20.6)	1.62 (41.1)	1.00 (25.4)	
3/4	18	-TTT-AN12-AS12-AN12	1.66 (42.2)	0.61 (15.5)	1.06 (27.0)	1.75 (44.4)	1.25 (31.8)	
7/8	22	-TTT-AN14-AS14-AN14	1.80 (45.7)	0.72 (18.3)	1.25 (31.8)	1.78 (45.2)	1.37 (34.9)	
1	25	-TTT-AN16-AS16-AN16	1.81 (46.0)	0.85 (21.5)	1.37 (34.9)	2.00 (50.8)	1.50 (38.1)	
1 1/4	32	-TTT-AN20-AS20-AN20	2.06 (52.3)	1.08 (27.5)	1.69 (42.9)	2.31 (58.7)	2.00 (50.8)	
1 1/2	38	-TTT-AN24-AS24-AN24	2.33 (59.2)	1.30 (33.0)	2.00 (50.8)	2.59 (65.8)	2.37 (60.3)	
2	50	-TTT-AN32-AS32-AN32	3.06 (77.7)	1.77 (45.0)	2.50 (63.5)	3.38 (85.9)	2.87 (73.0)	

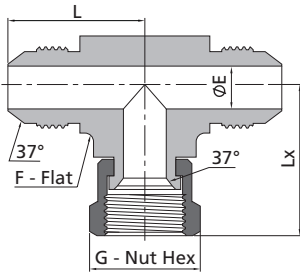

SAE 070433								
Tube O.D.		Basic Ordering Number	Dimensions, in. (mm)					
in.	mm		L	E	F	Lx	G	
1/8	3	-TTT-AN2-AN2-AS2	0.77 (19.6)	0.06 (1.6)	0.44 (11.1)	0.97 (24.6)	0.44 (11.1)	
3/16	4	-TTT-AN3-AN3-AS3	0.83 (21.1)	0.13 (3.2)	0.44 (11.1)	1.00 (25.4)	0.50 (12.7)	
1/4	6	-TTT-AN4-AN4-AS4	0.89 (22.6)	0.17 (4.4)	0.50 (12.7)	1.00 (25.4)	0.56 (14.3)	
5/16	8	-TTT-AN5-AN5-AS5	0.95 (24.1)	0.24 (6.0)	0.56 (14.3)	1.06 (26.9)	0.63 (15.9)	
3/8	10	-TTT-AN6-AN6-AS6	1.06 (26.9)	0.30 (7.5)	0.56 (14.3)	1.25 (31.8)	0.69 (17.5)	
1/2	12	-TTT-AN8-AN8-AS8	1.25 (31.8)	0.39 (9.9)	0.81 (20.6)	1.38 (35.1)	0.87 (22.2)	
5/8	16	-TTT-AN10-AN10-AS10	1.45 (36.8)	0.48 (12.3)	0.81 (20.6)	1.62 (41.1)	1.00 (25.4)	
3/4	18	-TTT-AN12-AN12-AS12	1.66 (42.2)	0.61 (15.5)	1.06 (27.0)	1.75 (44.4)	1.25 (31.8)	
7/8	22	-TTT-AN14-AN14-AS14	1.80 (45.7)	0.72 (18.3)	1.25 (31.8)	1.78 (45.2)	1.37 (34.9)	
1	25	-TTT-AN16-AN16-AS16	1.81 (46.0)	0.85 (21.5)	1.37 (34.9)	2.00 (50.8)	1.50 (38.1)	
1 1/4	32	-TTT-AN20-AN20-AS20	2.06 (52.3)	1.08 (27.5)	1.69 (42.9)	2.31 (58.7)	2.00 (50.8)	
1 1/2	38	-TTT-AN24-AN24-AS24	2.33 (59.2)	1.30 (33.0)	2.00 (50.8)	2.59 (65.8)	2.37 (60.3)	
2	50	-TTT-AN32-AN32-AS32	3.06 (77.7)	1.77 (45.0)	2.50 (63.5)	3.38 (85.9)	2.87 (73.0)	

Union Crosses

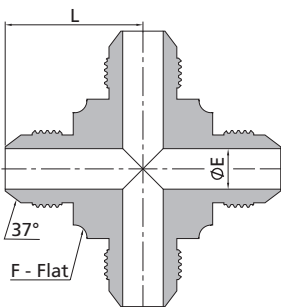

SAE 070501						
Tube O.D.		Basic Ordering Number	Dimensions, in. (mm)			
in.	mm		L	E	F	
1/8	3	-C-AN2	0.77 (19.6)	0.06 (1.6)	0.44 (11.1)	
3/16	4	-C-AN3	0.83 (21.1)	0.13 (3.2)	0.44 (11.1)	
1/4	6	-C-AN4	0.89 (22.6)	0.17 (4.4)	0.50 (12.7)	
5/16	8	-C-AN5	0.95 (24.1)	0.24 (6.0)	0.56 (14.3)	
3/8	10	-C-AN6	1.06 (26.9)	0.30 (7.5)	0.56 (14.3)	
1/2	12	-C-AN8	1.25 (31.8)	0.39 (9.9)	0.81 (20.6)	
5/8	16	-C-AN10	1.45 (36.8)	0.48 (12.3)	0.81 (20.6)	
3/4	18	-C-AN12	1.66 (42.2)	0.61 (15.5)	1.06 (27.0)	
7/8	22	-C-AN14	1.80 (45.7)	0.72 (18.3)	1.25 (31.8)	
1	25	-C-AN16	1.81 (46.0)	0.85 (21.5)	1.37 (34.9)	
1 1/4	32	-C-AN20	2.06 (52.3)	1.08 (27.5)	1.69 (42.9)	
1 1/2	38	-C-AN24	2.33 (59.2)	1.30 (33.0)	2.00 (50.8)	
2	50	-C-AN32	3.06 (77.7)	1.77 (45.0)	2.50 (63.5)	

info@fitokgroup.com
www.fitokgroup.com

FK-IC-GF-04-EN-170522

VL Series Vacuum Tube Fittings



Contents

Unions - U

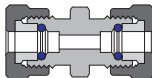

A-106

Reducing Unions - U

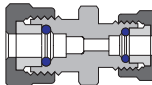

A-107

Tube Fitting Unions - U

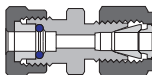

A-107

Union Elbows - LU

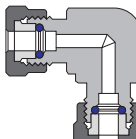

A-107

Union Tees - TTT

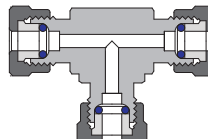

A-107

Male Connectors - CM

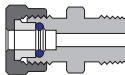

A-107

Adapters - CW

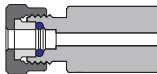

A-108

Nuts - N



A-108

O-rings - VI7



A-108

VL Series

Features

- Stainless steel construction, fluorocarbon FKM O-ring
- Available in tube sizes from 1/16" to 1 1/2"
- Working temperature: -25°F to 400°F (-31°C to 204°C)
- Knurled nut for easy, finger-tight assembly
- Reliable, repeatable sealing performance

Testing

- The VL vacuum fitting design has been helium leak tested to a maximum leak rate of 4×10^{-9} std cm³/s at ambient temperature.
- The leak rate increases as temperature increases due to permeation through the O-ring.

Cleaning and Packaging

- VL vacuum fittings meet the requirements of FITOK Standard Cleaning and Packaging.
- VL vacuum fittings are cleaned to remove machine oil, grease and loose particles.

Ordering Information

- The E dimension refers to the smallest nominal inside diameter of the part.
- To order straight fittings bored through, insert T to the ordering number.

Example: SS-TU-VL6
SS-TCM-VL8

Dimensions

Unions

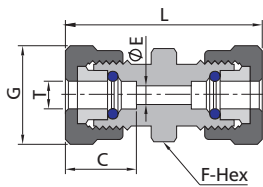

T-Tube O.D. (in.)	Ordering Number	Dimensions, in. (mm)				
		L	C	E	G	F
1/16	SS-U-VL1	1.23 (31.2)	0.43 (10.9)	0.05 (1.3)	3/8	3/8 (9.5)
1/8	SS-U-VL2	1.40 (35.6)	0.43 (10.9)	0.09 (2.3)	9/16	1/2 (12.7)
1/4	SS-U-VL4	1.63 (41.4)	0.62 (15.7)	0.18 (4.6)	11/16	5/8 (15.9)
3/8	SS-U-VL6	1.81 (46.0)	0.66 (16.8)	0.28 (7.1)	13/16	3/4 (19.1)
1/2	SS-U-VL8	1.84 (46.7)	0.80 (20.3)	0.40 (10.2)	15/16	7/8 (22.2)
5/8	SS-U-VL10	1.84 (46.7)	0.84 (21.3)	0.50 (12.7)	1 1/8	1 1/16 (27.0)
3/4	SS-U-VL12	2.05 (52.1)	0.94 (23.9)	0.62 (15.7)	1 1/4	1 3/16 (30.1)
1	SS-U-VL16	2.15 (54.6)	0.94 (23.9)	0.87 (22.1)	1 9/16	1 1/2 (38.1)
1 1/2	SS-U-VL24	2.27 (57.6)	0.94 (23.9)	1.38 (35.1)	2 1/16	2 1/8 (54.0)

Dimensions are for reference only and are subject to change.

Reducing Unions

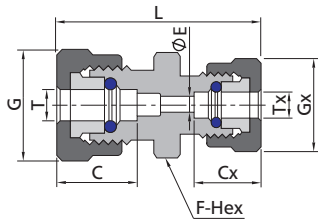

T-Tube O.D. (in.)	Tx-Tube O.D. (in.)	Ordering Number	Dimensions, in. (mm)						
			L	C	Cx	E	G	Gx	F
3/8	1/4	SS-U-VL6-VL4	1.72 (43.7)	0.66 (16.8)	0.62 (15.7)	0.18 (4.6)	13/16	11/16	3/4 (19.1)
1/2	1/4	SS-U-VL8-VL4	1.75 (44.4)	0.80 (20.3)	0.62 (15.7)	0.18 (4.6)	15/16	11/16	7/8 (22.2)

Tube Fitting Unions

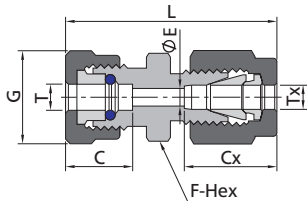

T-Tube O.D. (in.)	Tx-Tube O.D. (in.)	Ordering Number	Dimensions, in. (mm)						
			L	C	Cx	E	G	F	
1/4	1/4	SS-U-VL4-FL4	1.66 (42.2)	0.62 (15.7)	0.60 (15.2)	0.18 (4.6)	11/16	5/8 (15.9)	
3/8	3/8	SS-U-VL6-FL6	1.81 (46.0)	0.66 (16.8)	0.66 (16.8)	0.28 (7.1)	13/16	3/4 (19.1)	
1/2	1/2	SS-U-VL8-FL8	1.95 (49.5)	0.80 (20.3)	0.90 (22.9)	0.40 (10.2)	15/16	7/8 (22.2)	

Union Elbows

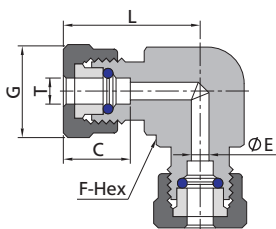

T-Tube O.D. (in.)	Ordering Number	Dimensions, in. (mm)				
		L	C	E	G	F
1/4	SS-LU-VL4	1.14 (29.0)	0.62 (15.7)	0.18 (4.6)	11/16	1/2 (12.7)
3/8	SS-LU-VL6	1.36 (34.5)	0.66 (16.8)	0.28 (7.1)	13/16	11/16 (17.5)
1/2	SS-LU-VL8	1.36 (34.5)	0.80 (20.3)	0.40 (10.2)	15/16	13/16 (20.6)

Union Tees

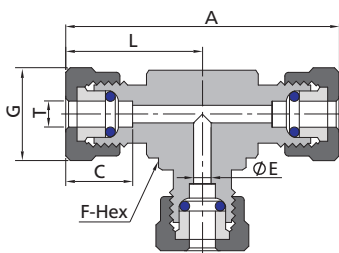

T-Tube O.D. (in.)	Ordering Number	Dimensions, in. (mm)					
		A	L	C	E	G	F
1/8	SS-TTT-VL2	2.12 (53.8)	1.06 (26.9)	0.43 (10.9)	0.09 (2.3)	9/16	1/2 (12.7)
1/4	SS-TTT-VL4	2.30 (58.4)	1.15 (29.2)	0.62 (15.7)	0.18 (4.6)	11/16	1/2 (12.7)
3/8	SS-TTT-VL6	2.72 (69.1)	1.36 (34.5)	0.66 (16.8)	0.28 (7.1)	13/16	11/16 (17.5)
1/2	SS-TTT-VL8	2.72 (69.1)	1.36 (34.5)	0.80 (20.3)	0.40 (10.2)	15/16	11/16 (17.5)
3/4	SS-TTT-VL12	3.30 (83.8)	1.65 (41.9)	0.94 (23.9)	0.62 (15.7)	1 1/4	15/16 (23.8)
1	SS-TTT-VL16	3.64 (92.4)	1.82 (46.2)	0.94 (23.9)	0.87 (22.1)	1 9/16	1 1/4 (31.8)

Male Connectors

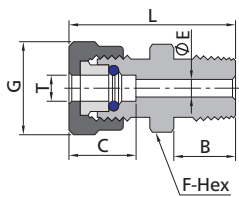

Tube O.D. (in.)	NPT Size in.	Ordering Number	Dimensions, in. (mm)					
			L	C	B	E	G	F
1/16	1/8	SS-CM-VL1-NS2	1.12 (28.4)	0.43 (10.9)	0.38 (9.6)	0.05 (1.3)	3/8	7/16 (11.1)
1/8	1/8	SS-CM-VL2-NS2	1.22 (31.0)	0.43 (10.9)	0.38 (9.6)	0.09 (2.3)	9/16	1/2 (12.7)
1/4	1/8	SS-CM-VL4-NS2	1.35 (34.3)	0.62 (15.7)	0.38 (9.6)	0.18 (4.6)	11/16	5/8 (15.9)
1/4	1/4	SS-CM-VL4-NS4	1.53 (38.9)	0.62 (15.7)	0.56 (14.2)	0.18 (4.6)	11/16	5/8 (15.9)
3/8	1/8	SS-CM-VL6-NS2	1.44 (36.6)	0.66 (16.8)	0.38 (9.6)	0.18 (4.6)	13/16	3/4 (19.1)
3/8	1/4	SS-CM-VL6-NS4	1.62 (41.1)	0.66 (16.8)	0.56 (14.2)	0.28 (7.1)	13/16	3/4 (19.1)
1/2	3/8	SS-CM-VL8-NS6	1.65 (41.9)	0.80 (20.3)	0.56 (14.2)	0.40 (10.2)	15/16	7/8 (22.2)
1/2	1/2	SS-CM-VL8-NS8	1.84 (46.7)	0.80 (20.3)	0.75 (19.1)	0.40 (10.2)	15/16	7/8 (22.2)
3/4	3/4	SS-CM-VL12-NS12	1.96 (49.8)	0.94 (23.9)	0.75 (19.1)	0.62 (15.7)	1 1/4	1 3/16 (30.1)
1	1	SS-CM-VL16-NS16	2.25 (57.2)	0.94 (23.9)	0.94 (23.9)	0.87 (22.1)	1 9/16	1 1/2 (38.1)

Adapters

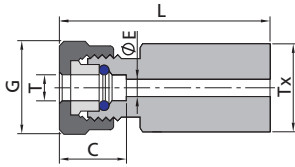

T-Tube O.D. (in.)	Tx-Tube O.D. (in.)	Ordering Number	Dimensions, in. (mm)			
			L	C	E	G
1/16	1/4	SS-CW-VL1-A4	1.12 (28.4)	0.43 (10.9)	0.05 (1.3)	3/8
1/8	1/4	SS-CW-VL2-A4	1.20 (30.5)	0.43 (10.9)	0.09 (2.3)	9/16
1/8	3/8	SS-CW-VL2-A6	1.21 (30.7)	0.43 (10.9)	0.09 (2.3)	9/16
1/4	1/4	SS-CW-VL4-A4	1.34 (34.0)	0.62 (15.7)	0.18 (4.6)	11/16
1/4	3/8	SS-CW-VL4-A6	1.33 (33.8)	0.62 (15.7)	0.18 (4.6)	11/16
1/4	1/2	SS-CW-VL4-A8	1.47 (37.3)	0.62 (15.7)	0.18 (4.6)	11/16
3/8	3/8	SS-CW-VL6-A6	1.47 (37.3)	0.66 (16.8)	0.28 (7.1)	13/16
3/8	1/2	SS-CW-VL6-A8	1.58 (40.1)	0.66 (16.8)	0.28 (7.1)	13/16
1/2	5/8	SS-CW-VL8-A10	1.64 (41.7)	0.80 (20.3)	0.40 (10.2)	15/16
1/2	3/4	SS-CW-VL8-A12	1.69 (42.9)	0.80 (20.3)	0.40 (10.2)	15/16
3/4	1	SS-CW-VL12-A16	1.78 (45.2)	0.94 (23.9)	0.62 (15.7)	1 1/4
1	1 1/4	SS-CW-VL16-A20	1.80 (45.7)	0.94 (23.9)	0.87 (22.1)	1 9/16
1 1/2	1 1/2	SS-CW-VL24-A24	1.98 (50.3)	0.94 (23.9)	1.25 (31.8)	2 1/16

Nuts

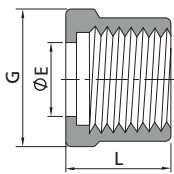

T-Tube O.D. (in.)	Ordering Number	Thread Size	Dimensions, in. (mm)		
			L	E	G
1/16	SS-N-VL1	1/4-20 UNC	0.38 (9.60)	0.07 (1.80)	3/8
1/8	SS-N-VL2	3/8-20 UN	0.41 (10.4)	0.13 (3.30)	9/16
1/4	SS-N-VL4	1/2-20 UNF	0.53 (13.5)	0.26 (6.60)	11/16
3/8	SS-N-VL6	5/8-20 UN	0.62 (15.7)	0.38 (9.60)	13/16
1/2	SS-N-VL8	3/4-20 UNEF	0.62 (15.7)	0.51 (13.0)	15/16
5/8	SS-N-VL10	15/16-20 UNEF	0.62 (15.7)	0.63 (16.0)	1 1/8
3/4	SS-N-VL12	1 1/16-20 UN	0.72 (18.3)	0.76 (19.3)	1 1/4
1	SS-N-VL16	1 3/8-20 UN	0.72 (18.3)	1.01 (25.6)	1 9/16
1 1/2	SS-N-VL24	1 7/8-20 UN	0.72 (18.3)	1.51 (38.4)	2 1/16

O-rings



T-Tube O.D. (in.)	Ordering Number	Material
1/16	VI7-001	70 durometer fluorocarbon FKM
1/8	VI7-006	
1/4	VI7-010	
3/8	VI7-012	
1/2	VI7-014	
5/8	VI7-114	
3/4	VI7-116	
1	VI7-120	
1 1/2	VI7-128	

info@fitokgroup.com
www.fitokgroup.com

FK-IC-GF-09-EN-180711

6 Series Pipe Fittings



Contents

Hex Nipples - PHN

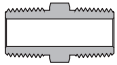

A-113

Hex Long Nipples - PLN



A-116

Close Nipples - PCN

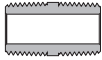

A-118

Special Pipe Nipples - PSN

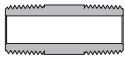

A-118

Adapters - PA



A-119

Reducing Bushings - PRB



A-122

Hex Couplings - PCG



A-125

Union Ball Joints - UBJ



A-126

Male Elbows - PME



A-126

Street Elbows - PSE



A-127

45° Street Elbows - PSV

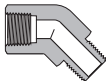

A-129

Female Elbows - PE



A-131

45° Female Elbows - PVE

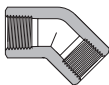

A-132

Male Tees - PMT

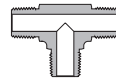

A-133

Female Branch Tees - PTB

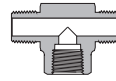

A-134

Female Run Tees - PTR

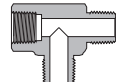

A-134

Male Street Tees - PST

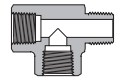

A-135

Male Branch Tees - PBT

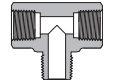

A-136

Female Tees - PT

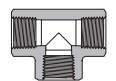

A-137

Female Crosses - PCR

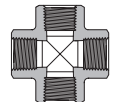

A-138

Pipe to Pipe Unions - PUP

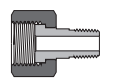

A-138

Hand Tight Adapter Fittings - HF

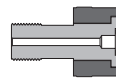

A-139

Pipe Plugs - PP



A-140

Hollow Hex Plugs - PI



A-141

Pipe Caps - PC

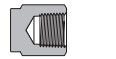

A-142

Ordering Number Description A-143

Features

- ⦿ The hardened threads with smooth surface finishing avoid galling and help to extend the fitting service life
- ⦿ Radius junction design for elbows provides smooth flow path
- ⦿ Every fitting is marked with size, material and heat number

Technical Data

- ⦿ Sizes range from 1/16 to 2
- ⦿ Thread Specifications:

Thread Type	Specification
NPT	ASME B1.20.1, SAE AS71051
ISO Tapered	ISO 7-1, BS 21, JIS B0203
ISO Parallel	ISO 228, JIS B0202
SAE/MS	ASME B1.1, SAE J475
Metric	ISO 261

- ⦿ Working Temperature:
For the working temperatures of FITOK pipe fittings, please see A-10.

- ⦿ Working Pressure:

1. Catalog working pressures shown are based on ANSI/ASME B31.3 at ambient temperature, to determine working pressures in accordance with ANSI/ASME B31.1 multiply catalog working pressures shown by the factor from the table below.

Material	Factor
Carbon steel	0.85
Brass	1.0

2. Use the allowable working pressure at ambient temperature to multiply the elevated temperature factors to get the working pressure at elevated temperature. To know the elevated temperature factor, please see F-14.
3. For technical information of NPT thread and ISO tapered thread, please see page A-06 and A-07.

Materials

Material	Bar Stock	Forging	Designator
316 stainless steel	ASTM A276, ASME SA479, EN 1.4401	ASTM A182, ASME SA182, EN 1.4401	SS
304 stainless steel	ASTM A276, ASME SA479, EN 1.4301	ASTM A182, ASME SA182, EN 1.4301	S4
Alloy 400	ASTM B164, ASME SB164	ASTM B564 ASME SB564	M
Alloy 600	ASTM B166, ASME SB166	ASTM B564, ASME SB564	INC
Alloy C-276	ASTM B574	ASTM B564,	HC
Brass	ASME B16/ASTM B453	ASTM B283	B
Carbon steel	ASTM A108	ASTM A105	CS
904L stainless steel	ASTM B649	ASTM A182	904L

Cautions:

- ⦿ Do not loosen or tighten fittings when system is pressurized.
- ⦿ Always use proper thread sealants on tapered pipe threads.
- ⦿ Confirm the sealing type when choosing the straight threads, make sure the construction of the matching threads comply with the sealing type.

Dimensions

Hex Nipples

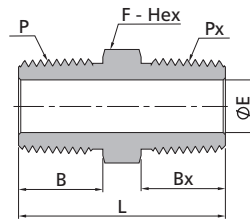

Male NPT Threads										
P-NPT Size	Px-NPT Size	Basic Ordering Number	Dimensions, in. (mm)					Working Pressure psig (bar)		
			L	F	B	Bx	E	316 SS, Steel	Brass	
1/16	1/16	-PHN-NS1	1.01 (25.6)	0.31 (7.9)	0.38 (9.7)	0.38 (9.7)	0.12 (3.0)	11000 (757)	5500 (378)	
1/8	1/16	-PHN-NS2-NS1	1.01 (25.6)	0.44 (11.1)	0.38 (9.7)	0.38 (9.7)	0.12 (3.0)	11000 (757)	5500 (378)	
1/8	1/8	-PHN-NS2	1.01 (25.6)	0.44 (11.1)	0.38 (9.7)	0.38 (9.7)	0.19 (4.8)	10000 (690)	5000 (344)	
1/4	1/16	-PHN-NS4-NS1	1.22 (31.0)	0.56 (14.3)	0.56 (14.2)	0.38 (9.7)	0.12 (3.0)	9500 (655)	4700 (324)	
1/4	1/8	-PHN-NS4-NS2	1.22 (31.0)	0.56 (14.3)	0.56 (14.2)	0.38 (9.7)	0.19 (4.8)	9500 (655)	4700 (324)	
1/4	1/4	-PHN-NS4	1.40 (35.6)	0.56 (14.3)	0.56 (14.2)	0.56 (14.2)	0.28 (7.1)	8000 (551)	4000 (275)	
3/8	1/16	-PHN-NS6-NS1	1.25 (31.8)	0.69 (17.5)	0.56 (14.2)	0.38 (9.7)	0.12 (3.0)	7800 (537)	3900 (268)	
3/8	1/8	-PHN-NS6-NS2	1.25 (31.8)	0.69 (17.5)	0.56 (14.2)	0.38 (9.7)	0.19 (4.8)	7800 (537)	3900 (268)	
3/8	1/4	-PHN-NS6-NS4	1.43 (36.3)	0.69 (17.5)	0.56 (14.2)	0.56 (14.2)	0.28 (7.1)	8000 (551)	4000 (275)	
3/8	3/8	-PHN-NS6	1.43 (36.3)	0.69 (17.5)	0.56 (14.2)	0.56 (14.2)	0.38 (9.7)	7800 (537)	3900 (268)	
1/2	1/8	-PHN-NS8-NS2	1.47 (37.3)	0.87 (22.2)	0.75 (19.1)	0.38 (9.7)	0.19 (4.8)	7700 (530)	3800 (261)	
1/2	1/4	-PHN-NS8-NS4	1.65 (41.9)	0.87 (22.2)	0.75 (19.1)	0.56 (14.2)	0.28 (7.1)	8000 (551)	4000 (275)	
1/2	3/8	-PHN-NS8-NS6	1.65 (41.9)	0.87 (22.2)	0.75 (19.1)	0.56 (14.2)	0.38 (9.7)	7800 (537)	3900 (268)	
1/2	1/2	-PHN-NS8	1.84 (46.7)	0.87 (22.2)	0.75 (19.1)	0.75 (19.1)	0.47 (11.9)	7700 (530)	3800 (261)	
3/4	1/8	-PHN-NS12-NS2	1.59 (40.4)	1.06 (27.0)	0.75 (19.1)	0.38 (9.7)	0.19 (4.8)	7300 (502)	3600 (248)	
3/4	1/4	-PHN-NS12-NS4	1.65 (41.9)	1.06 (27.0)	0.75 (19.1)	0.56 (14.2)	0.28 (7.1)	8000 (551)	4000 (275)	
3/4	3/8	-PHN-NS12-NS6	1.78 (45.2)	1.06 (27.0)	0.75 (19.1)	0.56 (14.2)	0.38 (9.7)	7800 (537)	3900 (268)	
3/4	1/2	-PHN-NS12-NS8	1.84 (46.7)	1.06 (27.0)	0.75 (19.1)	0.75 (19.1)	0.47 (11.9)	7700 (530)	3800 (261)	
3/4	3/4	-PHN-NS12	1.84 (46.7)	1.06 (27.0)	0.75 (19.1)	0.75 (19.1)	0.62 (15.7)	7300 (502)	3600 (248)	
1	1/8	-PHN-NS16-NS2	1.78 (45.2)	1.37 (34.9)	0.94 (23.9)	0.38 (9.7)	0.19 (4.8)	6500 (448)	3300 (227)	
1	1/4	-PHN-NS16-NS4	1.94 (49.3)	1.37 (34.9)	0.94 (23.9)	0.56 (14.2)	0.28 (7.1)	5300 (365)	2600 (179)	
1	3/8	-PHN-NS16-NS6	1.97 (50.0)	1.37 (34.9)	0.94 (23.9)	0.56 (14.2)	0.38 (9.7)	6500 (448)	3300 (227)	
1	1/2	-PHN-NS16-NS8	2.13 (54.1)	1.37 (34.9)	0.94 (23.9)	0.75 (19.1)	0.47 (11.9)	6500 (448)	3300 (227)	
1	3/4	-PHN-NS16-NS12	2.13 (54.1)	1.37 (34.9)	0.94 (23.9)	0.75 (19.1)	0.62 (15.7)	6500 (448)	3300 (227)	
1	1	-PHN-NS16	2.32 (58.9)	1.37 (34.9)	0.94 (23.9)	0.94 (23.9)	0.88 (22.4)	5300 (365)	2600 (179)	
1 1/4	1	-PHN-NS20-NS16	2.45 (62.2)	1.75 (44.5)	0.94 (23.9)	0.94 (23.9)	0.88 (22.4)	5300 (365)	2600 (179)	
1 1/4	1 1/4	-PHN-NS20	2.48 (62.9)	1.75 (44.5)	0.94 (23.9)	0.94 (23.9)	1.13 (28.6)	6000 (410)	3000 (200)	
1 1/2	1 1/2	-PHN-NS24	2.61 (66.3)	2.00 (50.8)	1.03 (26.2)	1.03 (26.2)	1.34 (34.0)	5000 (344)	2500 (172)	
2	2	-PHN-NS32	3.06 (77.7)	2.75 (69.9)	1.03 (26.2)	1.03 (26.2)	1.77 (45.0)	3900 (268)	1900 (130)	

Male ISO Tapered Threads										
P-RT Size	Px-RT Size	Basic Ordering Number	Dimensions, in. (mm)					Working Pressure psig (bar)		
			L	F	B	Bx	E	316 SS, Steel	Brass	
1/8	1/8	-PHN-RT2	1.01 (25.6)	0.44 (11.1)	0.38 (9.7)	0.38 (9.7)	0.19 (4.8)	10000 (690)	5000 (344)	
1/4	1/4	-PHN-RT4	1.40 (35.6)	0.56 (14.3)	0.56 (14.2)	0.56 (14.2)	0.28 (7.1)	8000 (551)	4000 (275)	
3/8	3/8	-PHN-RT6	1.43 (36.3)	0.69 (17.5)	0.56 (14.2)	0.56 (14.2)	0.38 (9.7)	7800 (537)	3900 (268)	
1/2	1/2	-PHN-RT8	1.84 (46.7)	0.87 (22.2)	0.75 (19.1)	0.75 (19.1)	0.47 (11.9)	7700 (530)	3800 (261)	
3/4	3/4	-PHN-RT12	1.84 (46.7)	1.06 (27.0)	0.75 (19.1)	0.75 (19.1)	0.62 (15.7)	7300 (502)	3600 (248)	
1	1	-PHN-RT16	2.32 (58.9)	1.37 (34.9)	0.94 (23.9)	0.94 (23.9)	0.88 (22.4)	5300 (365)	2600 (179)	

Hex Nipples

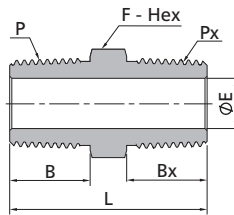

Male NPT Threads			Male ISO Tapered Threads							
P-NPT Size	Px-RT Size	Basic Ordering Number	Dimensions, in. (mm)					Working Pressure psig (bar)		
			L	F	B	Bx	E	316 SS, Steel	Brass	
1/8	1/8	-PHN-NS2-RT2	1.01 (25.6)	0.44 (11.1)	0.38 (9.7)	0.38 (9.7)	0.19 (4.8)	10000 (690)	5000 (344)	
1/4	1/4	-PHN-NS4-RT4	1.40 (35.6)	0.56 (14.3)	0.56 (14.2)	0.56 (14.2)	0.28 (7.1)	8000 (551)	4000 (275)	
3/8	3/8	-PHN-NS6-RT6	1.43 (36.3)	0.69 (17.5)	0.56 (14.2)	0.56 (14.2)	0.38 (9.7)	7800 (537)	3900 (268)	
1/2	1/2	-PHN-NS8-RT8	1.84 (46.7)	0.87 (22.2)	0.75 (19.1)	0.75 (19.1)	0.47 (11.9)	7700 (530)	3800 (261)	
3/4	3/4	-PHN-NS12-RT12	1.84 (46.7)	1.06 (27.0)	0.75 (19.1)	0.75 (19.1)	0.62 (15.7)	7300 (502)	3600 (248)	
1	1	-PHN-NS16-RT16	2.32 (58.9)	1.37 (34.9)	0.94 (23.9)	0.94 (23.9)	0.88 (22.4)	5300 (365)	2600 (179)	

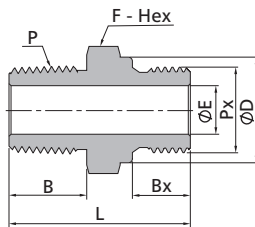

Male NPT Threads			Male ISO parallel Threads							
P-NPT Size	Px-RS Size	Basic Ordering Number	Dimensions, in. (mm)					Working Pressure psig (bar)		
			L	F	B	Bx	E	D	316 SS, Steel	Brass
1/8	1/8	-PHN-NS2-RS2	1.09 (27.7)	0.56 (14.3)	0.38 (9.7)	0.28 (7.1)	0.16 (4.1)	0.54 (13.7)	9600 (662)	4800 (331)
1/4	1/4	-PHN-NS4-RS4	1.45 (36.8)	0.75 (19.1)	0.56 (14.2)	0.44 (11.2)	0.23 (5.8)	0.71 (18.0)	10300 (709)	5100 (351)
3/8	3/8	-PHN-NS6-RS6	1.48 (37.6)	0.87 (22.2)	0.56 (14.2)	0.44 (11.2)	0.31 (7.9)	0.85 (21.6)	7800 (537)	3900 (268)
1/2	1/2	-PHN-NS8-RS8	1.75 (44.4)	1.06 (27.0)	0.75 (19.1)	0.56 (14.2)	0.47 (11.9)	1.02 (25.9)	7600 (523)	3800 (261)
3/4	3/4	-PHN-NS12-RS12	1.93 (49.0)	1.31 (33.3)	0.75 (19.1)	0.62 (15.7)	0.62 (15.7)	1.26 (32.0)	7300 (502)	3600 (248)
1	1	-PHN-NS16-RS16	2.23 (56.6)	1.63 (41.3)	0.94 (23.9)	0.72 (18.3)	0.78 (19.8)	1.53 (38.9)	7400 (509)	3700 (254)

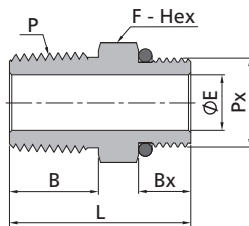

Male NPT Threads			Male SAE/MS Straight Threads					
P-NPT Size	Px-SAE/MS Thread Size	Basic Ordering Number	Dimensions, in. (mm)					Working Pressure psig (bar)
			L	F	B	Bx	E	316 SS, Steel
1/4	7/16-20	-PHN-NS4-ST7	1.20 (30.5)	0.56 (14.3)	0.56 (14.2)	0.36 (9.1)	0.20 (5.1)	4500 (310)
3/8	9/16-18	-PHN-NS6-ST9	1.26 (32.0)	0.69 (17.5)	0.56 (14.2)	0.36 (9.1)	0.28 (7.1)	4500 (310)
1/2	3/4-16	-PHN-NS8-ST12	1.53 (38.9)	0.87 (22.2)	0.75 (19.1)	0.44 (11.2)	0.42 (10.7)	4500 (310)
3/4	1 1/16-12	-PHN-NS12-ST17	1.75 (44.4)	1.25 (31.8)	0.75 (19.1)	0.59 (15.0)	0.62 (15.7)	3600 (248)
1	1 5/16-12	-PHN-NS16-ST21	2.00 (50.8)	1.50 (38.1)	0.94 (23.9)	0.59 (15.0)	0.88 (22.4)	2900 (199)

Hex Nipples

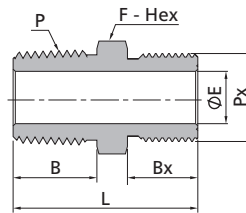

Male NPT Threads			Male Metric Threads					
P-NPT Size	Px-Metric Size	Basic Ordering Number	Dimensions, mm (in.)					Working Pressure psig (bar) 316 SS, Steel
			L	F	B	Bx	E	
1/8	M20 x 1.5	-PHN-NS2-MS20	32.7 (1.29)	22.2 (0.87)	9.7 (0.38)	16.0 (0.63)	5.0 (0.20)	7700 (530)
1/4	M8 x 1	-PHN-NS4-MS8	29.0 (1.14)	14.3 (0.56)	14.2 (0.56)	9.0 (0.35)	3.2 (0.13)	8000 (551)
1/4	M14 x 1.5	-PHN-NS4-MS14	34.2 (1.35)	15.9 (0.63)	14.2 (0.56)	13.0 (0.51)	7.0 (0.28)	8000 (551)
1/4	M16 x 1.5	-PHN-NS4-MS16	35.2 (1.39)	17.5 (0.69)	14.2 (0.56)	14.0 (0.55)	7.1 (0.28)	7800 (537)
1/4	M20 x 1.5	-PHN-NS4-MS20	37.2 (1.46)	22.2 (0.87)	14.2 (0.56)	16.0 (0.63)	7.1 (0.28)	7700 (530)
3/8	M14 x 1.5	-PHN-NS6-MS14	34.2 (1.35)	17.5 (0.69)	14.2 (0.56)	13.0 (0.51)	7.0 (0.28)	7800 (537)
3/8	M20 x 1.5	-PHN-NS6-MS20	37.2 (1.46)	22.2 (0.87)	14.2 (0.56)	16.0 (0.63)	9.5 (0.37)	7700 (530)
3/8	M24 x 1.5	-PHN-NS6-MS24	38.2 (1.50)	25.4 (1.00)	14.2 (0.56)	17.0 (0.67)	9.5 (0.37)	7400 (509)
1/2	M14 x 1.5	-PHN-NS8-MS14	39.1 (1.54)	22.2 (0.87)	19.1 (0.75)	13.0 (0.51)	7.2 (0.28)	7700 (530)
1/2	M20 x 1.5	-PHN-NS8-MS20	42.0 (1.65)	22.2 (0.87)	19.1 (0.75)	16.0 (0.63)	10.0 (0.39)	7700 (530)
1/2	M24 x 1.5	-PHN-NS8-MS24	43.5 (1.71)	25.4 (1.00)	19.1 (0.75)	17.0 (0.67)	11.9 (0.47)	7400 (509)
3/4	M20 x 1.5	-PHN-NS12-MS20	42.1 (1.66)	27.0 (1.06)	19.1 (0.75)	16.0 (0.63)	10.8 (0.43)	7300 (502)
3/4	M27 x 2	-PHN-NS12-MS27	46.7 (1.84)	31.8 (1.25)	19.1 (0.75)	18.0 (0.71)	15.8 (0.62)	6100 (420)
1	M30 x 2	-PHN-NS16-MS30	56.3 (2.22)	34.9 (1.37)	23.9 (0.94)	20.0 (0.79)	19.4 (0.76)	6100 (420)

Male ISO Tapered Threads			Male Metric Threads					
P-RT Size	Px-Metric Size	Basic Ordering Number	Dimensions, mm (in.)					Working Pressure psig (bar) 316 SS, Steel
			L	F	B	Bx	E	
1/8	M20 x 1.5	-PHN-RT2-MS20	32.7 (1.29)	22.2 (0.87)	9.7 (0.38)	16.0 (0.63)	5.0 (0.20)	7700 (530)
1/4	M12 x 1.5	-PHN-RT4-MS12	33.4 (1.31)	14.3 (0.56)	14.2 (0.56)	12.0 (0.47)	6.0 (0.24)	8000 (551)
1/4	M20 x 1.5	-PHN-RT4-MS20	37.2 (1.46)	22.2 (0.87)	14.2 (0.56)	16.0 (0.63)	7.0 (0.28)	7700 (530)
3/8	M20 x 1.5	-PHN-RT6-MS20	37.2 (1.46)	22.2 (0.87)	14.2 (0.56)	16.0 (0.63)	9.5 (0.37)	7700 (530)
1/2	M20 x 1.5	-PHN-RT8-MS20	42.0 (1.65)	22.2 (0.87)	19.1 (0.75)	16.0 (0.63)	10.0 (0.39)	7700 (530)

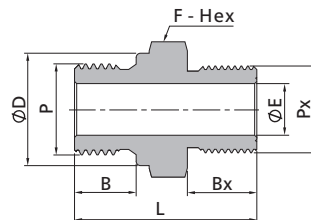

Male ISO Parallel Threads			Male Metric Threads						
P-RS Size	Px-Metric Size	Basic Ordering Number	Dimensions, mm (in.)						Working Pressure psig (bar) 316 SS, Steel
			L	F	B	Bx	E	D	
1/8	M20 x 1.5	-PHN-RS2-MS20	32.6 (1.28)	22.2 (0.87)	7.1 (0.28)	16.0 (0.63)	4.0 (0.16)	13.7 (0.54)	7700 (530)
1/4	M18 x 1.5	-PHN-RS4-MS18	34.2 (1.35)	20.6 (0.81)	11.2 (0.44)	15.0 (0.59)	5.9 (0.23)	18.0 (0.71)	7800 (537)
1/4	M20 x 1.5	-PHN-RS4-MS20	37.2 (1.46)	22.2 (0.87)	11.2 (0.44)	16.0 (0.63)	5.9 (0.23)	18.0 (0.71)	7700 (530)
3/8	M20 x 1.5	-PHN-RS6-MS20	37.2 (1.46)	22.2 (0.87)	11.2 (0.44)	16.0 (0.63)	7.9 (0.31)	21.6 (0.85)	7700 (530)
1/2	M20 x 1.5	-PHN-RS8-MS20	40.2 (1.58)	27.0 (1.06)	14.0 (0.55)	16.0 (0.63)	11.9 (0.47)	25.9 (1.02)	7700 (530)

Hex Nipples

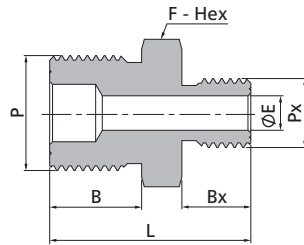

Pipe Fittings
Weld Fittings

Male Metric Threads			Dimensions, mm (in.)					Working Pressure psig (bar) 316 SS, Steel
P-Metric Size	Px-Metric Size	Basic Ordering Number	L	F	B	Bx	E	
M20 x 1.5	M10 x 1	-PHN-MS20-MS10	34.0 (1.34)	22.0 (0.87)	16.0 (0.63)	11.0 (0.43)	4.0 (0.16)	10000 (690)
M20 x 1.5	M12 x 1.5	-PHN-MS20-MS12	35.0 (1.38)	22.0 (0.87)	16.0 (0.63)	12.0 (0.47)	6.0 (0.24)	9000 (620)
M20 x 1.5	M14 x 1.5	-PHN-MS20-MS14	36.0 (1.42)	22.0 (0.87)	16.0 (0.63)	13.0 (0.51)	7.2 (0.28)	8000 (551)
M20 x 1.5	M16 x 1.5	-PHN-MS20-MS16	37.0 (1.46)	22.0 (0.87)	16.0 (0.63)	14.0 (0.55)	9.0 (0.35)	7800 (537)
M20 x 1.5	M20 x 1.5	-PHN-MS20	39.0 (1.54)	22.0 (0.87)	16.0 (0.63)	16.0 (0.63)	10.8 (0.43)	7700 (530)
M27 x 2	M27 x 2	-PHN-MS27	44.5 (1.75)	30.0 (1.18)	18.0 (0.71)	18.0 (0.71)	16.1 (0.63)	7300 (502)

Hex Long Nipples

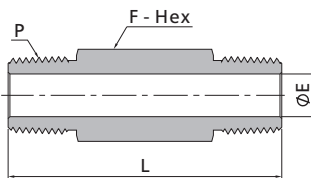

Male NPT Threads		Dimensions, in. (mm)			Working Pressure psig (bar)	
P-NPT Size	Basic Ordering Number	L	F	E	316 SS, Steel	Brass
1/8	-PLN-NS2-1.5	1.50 (38.1)	0.44 (11.1)	0.19 (4.8)	10000 (690)	5000 (344)
1/8	-PLN-NS2-2	2.00 (50.8)	0.44 (11.1)	0.19 (4.8)	10000 (690)	5000 (344)
1/8	-PLN-NS2-2.5	2.50 (63.5)	0.44 (11.1)	0.19 (4.8)	10000 (690)	5000 (344)
1/8	-PLN-NS2-3	3.00 (76.2)	0.44 (11.1)	0.19 (4.8)	10000 (690)	5000 (344)
1/4	-PLN-NS4-1.5	1.50 (38.1)	0.56 (14.3)	0.28 (7.1)	8000 (551)	4000 (275)
1/4	-PLN-NS4-2	2.00 (50.8)	0.56 (14.3)	0.28 (7.1)	8000 (551)	4000 (275)
1/4	-PLN-NS4-2.5	2.50 (63.5)	0.56 (14.3)	0.28 (7.1)	8000 (551)	4000 (275)
1/4	-PLN-NS4-3	3.00 (76.2)	0.56 (14.3)	0.28 (7.1)	8000 (551)	4000 (275)
1/4	-PLN-NS4-4	4.00 (101.6)	0.56 (14.3)	0.28 (7.1)	8000 (551)	4000 (275)
3/8	-PLN-NS6-1.5	1.50 (38.1)	0.69 (17.5)	0.38 (9.7)	7800 (537)	3900 (268)
3/8	-PLN-NS6-2	2.00 (50.8)	0.69 (17.5)	0.38 (9.7)	7800 (537)	3900 (268)
3/8	-PLN-NS6-2.5	2.50 (63.5)	0.69 (17.5)	0.38 (9.7)	7800 (537)	3900 (268)
3/8	-PLN-NS6-3	3.00 (76.2)	0.69 (17.5)	0.38 (9.7)	7800 (537)	3900 (268)
3/8	-PLN-NS6-4	4.00 (101.6)	0.69 (17.5)	0.38 (9.7)	7800 (537)	3900 (268)
1/2	-PLN-NS8-2	2.00 (50.8)	0.87 (22.2)	0.47 (11.9)	7700 (530)	3800 (261)
1/2	-PLN-NS8-3	3.00 (76.2)	0.87 (22.2)	0.47 (11.9)	7700 (530)	3800 (261)
1/2	-PLN-NS8-4	4.00 (101.6)	0.87 (22.2)	0.47 (11.9)	7700 (530)	3800 (261)
1/2	-PLN-NS8-6	6.00 (152.4)	0.87 (22.2)	0.47 (11.9)	7700 (530)	3800 (261)
3/4	-PLN-NS12-2	2.00 (50.8)	1.06 (27.0)	0.62 (15.7)	7300 (502)	3600 (248)
3/4	-PLN-NS12-3	3.00 (76.2)	1.06 (27.0)	0.62 (15.7)	7300 (502)	3600 (248)
3/4	-PLN-NS12-4	4.00 (101.6)	1.06 (27.0)	0.62 (15.7)	7300 (502)	3600 (248)
1	-PLN-NS16-3	3.00 (76.2)	1.37 (34.9)	0.88 (22.4)	5300 (365)	2600 (179)
1	-PLN-NS16-4	4.00 (101.6)	1.37 (34.9)	0.88 (22.4)	5300 (365)	2600 (179)

Hex Long Nipples

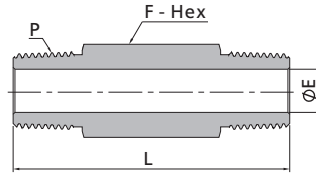

Male ISO Tapered Threads						
P-RT Size	Basic Ordering Number	Dimensions, in. (mm)			Working Pressure psig (bar)	
		L	F	E	316 SS, Steel	Brass
1/8	-PLN-RT2-1.5	1.50 (38.1)	0.44 (11.1)	0.19 (4.8)	10000 (690)	5000 (344)
1/8	-PLN-RT2-2	2.00 (50.8)	0.44 (11.1)	0.19 (4.8)	10000 (690)	5000 (344)
1/8	-PLN-RT2-2.5	2.50 (63.5)	0.44 (11.1)	0.19 (4.8)	10000 (690)	5000 (344)
1/8	-PLN-RT2-3	3.00 (76.2)	0.44 (11.1)	0.19 (4.8)	10000 (690)	5000 (344)
1/4	-PLN-RT4-1.5	1.50 (38.1)	0.56 (14.3)	0.28 (7.1)	8000 (551)	4000 (275)
1/4	-PLN-RT4-2	2.00 (50.8)	0.56 (14.3)	0.28 (7.1)	8000 (551)	4000 (275)
1/4	-PLN-RT4-2.5	2.50 (63.5)	0.56 (14.3)	0.28 (7.1)	8000 (551)	4000 (275)
1/4	-PLN-RT4-3	3.00 (76.2)	0.56 (14.3)	0.28 (7.1)	8000 (551)	4000 (275)
1/4	-PLN-RT4-4	4.00 (101.6)	0.56 (14.3)	0.28 (7.1)	8000 (551)	4000 (275)
3/8	-PLN-RT6-1.5	1.50 (38.1)	0.69 (17.5)	0.38 (9.7)	7800 (537)	3900 (268)
3/8	-PLN-RT6-2	2.00 (50.8)	0.69 (17.5)	0.38 (9.7)	7800 (537)	3900 (268)
3/8	-PLN-RT6-2.5	2.50 (63.5)	0.69 (17.5)	0.38 (9.7)	7800 (537)	3900 (268)
3/8	-PLN-RT6-3	3.00 (76.2)	0.69 (17.5)	0.38 (9.7)	7800 (537)	3900 (268)
3/8	-PLN-RT6-4	4.00 (101.6)	0.69 (17.5)	0.38 (9.7)	7800 (537)	3900 (268)
1/2	-PLN-RT8-2	2.00 (50.8)	0.87 (22.2)	0.47 (11.9)	7700 (530)	3800 (261)
1/2	-PLN-RT8-3	3.00 (76.2)	0.87 (22.2)	0.47 (11.9)	7700 (530)	3800 (261)
1/2	-PLN-RT8-4	4.00 (101.6)	0.87 (22.2)	0.47 (11.9)	7700 (530)	3800 (261)
1/2	-PLN-RT8-6	6.00 (152.4)	0.87 (22.2)	0.47 (11.9)	7700 (530)	3800 (261)
3/4	-PLN-RT12-2	2.00 (50.8)	1.06 (27.0)	0.62 (15.7)	7300 (502)	3600 (248)
3/4	-PLN-RT12-3	3.00 (76.2)	1.06 (27.0)	0.62 (15.7)	7300 (502)	3600 (248)
3/4	-PLN-RT12-4	4.00 (101.6)	1.06 (27.0)	0.62 (15.7)	7300 (502)	3600 (248)
1	-PLN-RT16-3	3.00 (76.2)	1.37 (34.9)	0.88 (22.4)	5300 (365)	2600 (179)
1	-PLN-RT16-4	4.00 (101.6)	1.37 (34.9)	0.88 (22.4)	5300 (365)	2600 (179)

Close Nipples

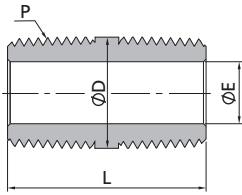

Pipe Fittings
Weld Fittings

Male NPT Threads						
P-NPT Size	Basic Ordering Number	Dimensions, in. (mm)			Working Pressure psig (bar)	
		L	D	E	316 SS, Steel	Brass
1/16	-PCN-NS1	0.75 (19.1)	0.31 (7.9)	0.12 (3.0)	11000 (757)	5500 (378)
1/8	-PCN-NS2	0.75 (19.1)	0.41 (10.3)	0.19 (4.8)	10000 (690)	5000 (344)
1/4	-PCN-NS4	1.12 (28.4)	0.54 (13.7)	0.28 (7.1)	8000 (551)	4000 (275)
3/8	-PCN-NS6	1.12 (28.4)	0.67 (17.1)	0.38 (9.6)	7800 (537)	3900 (268)
1/2	-PCN-NS8	1.50 (38.1)	0.84 (21.3)	0.47 (11.9)	7700 (530)	3800 (261)
3/4	-PCN-NS12	1.50 (38.1)	1.05 (26.7)	0.62 (15.7)	7300 (502)	3600 (248)
1	-PCN-NS16	1.88 (47.8)	1.31 (33.4)	0.88 (22.4)	5300 (365)	2600 (179)

Male ISO Tapered Threads						
P-RT Size	Basic Ordering Number	Dimensions, in. (mm)			Working Pressure psig (bar)	
		L	D	E	316 SS, Steel	Brass
1/16	-PCN-RT1	0.75 (19.1)	0.31 (7.9)	0.12 (3.0)	11000 (757)	5500 (378)
1/8	-PCN-RT2	0.75 (19.1)	0.41 (10.3)	0.19 (4.8)	10000 (690)	5000 (344)
1/4	-PCN-RT4	1.12 (28.4)	0.54 (13.7)	0.28 (7.1)	8000 (551)	4000 (275)
3/8	-PCN-RT6	1.12 (28.4)	0.67 (17.1)	0.38 (9.7)	7800 (537)	3900 (268)
1/2	-PCN-RT8	1.50 (38.1)	0.84 (21.3)	0.47 (11.9)	7700 (530)	3800 (261)
3/4	-PCN-RT12	1.50 (38.1)	1.05 (26.7)	0.62 (15.7)	7300 (502)	3600 (248)
1	-PCN-RT16	1.88 (47.8)	1.31 (33.4)	0.88 (22.4)	5300 (365)	2600 (179)

Special Pipe Nipples

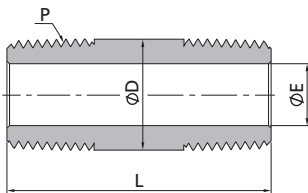

Male NPT Threads						
P-NPT Size	Basic Ordering Number	Dimensions, in. (mm)			Working Pressure psig (bar)	
		L	D	E	316 SS, Steel	Brass
1/8	-PSN-NS2-1.5	1.50 (38.1)	0.41 (10.3)	0.19 (4.8)	10000 (690)	5000 (344)
1/8	-PSN-NS2-2	2.00 (50.8)	0.41 (10.3)	0.19 (4.8)	10000 (690)	5000 (344)
1/8	-PSN-NS2-2.5	2.50 (63.5)	0.41 (10.3)	0.19 (4.8)	10000 (690)	5000 (344)
1/8	-PSN-NS2-3	3.00 (76.2)	0.41 (10.3)	0.19 (4.8)	10000 (690)	5000 (344)
1/4	-PSN-NS4-1.5	1.50 (38.1)	0.54 (13.7)	0.28 (7.1)	8000 (551)	4000 (275)
1/4	-PSN-NS4-2	2.00 (50.8)	0.54 (13.7)	0.28 (7.1)	8000 (551)	4000 (275)
1/4	-PSN-NS4-2.5	2.50 (63.5)	0.54 (13.7)	0.28 (7.1)	8000 (551)	4000 (275)
1/4	-PSN-NS4-3	3.00 (76.2)	0.54 (13.7)	0.28 (7.1)	8000 (551)	4000 (275)
1/4	-PSN-NS4-4	4.00 (101.6)	0.54 (13.7)	0.28 (7.1)	8000 (551)	4000 (275)
3/8	-PSN-NS6-1.5	1.50 (38.1)	0.67 (17.1)	0.38 (9.7)	7800 (537)	3900 (268)
3/8	-PSN-NS6-2	2.00 (50.8)	0.67 (17.1)	0.38 (9.7)	7800 (537)	3900 (268)
3/8	-PSN-NS6-2.5	2.50 (63.5)	0.67 (17.1)	0.38 (9.7)	7800 (537)	3900 (268)
3/8	-PSN-NS6-3	3.00 (76.2)	0.67 (17.1)	0.38 (9.7)	7800 (537)	3900 (268)
3/8	-PSN-NS6-4	4.00 (101.6)	0.67 (17.1)	0.38 (9.7)	7800 (537)	3900 (268)
1/2	-PSN-NS8-2	2.00 (50.8)	0.84 (21.3)	0.47 (11.9)	7700 (530)	3800 (261)
1/2	-PSN-NS8-3	3.00 (76.2)	0.84 (21.3)	0.47 (11.9)	7700 (530)	3800 (261)
1/2	-PSN-NS8-4	4.00 (101.6)	0.84 (21.3)	0.47 (11.9)	7700 (530)	3800 (261)
1/2	-PSN-NS8-6	6.00 (152.4)	0.84 (21.3)	0.47 (11.9)	7700 (530)	3800 (261)
3/4	-PSN-NS12-2	2.00 (50.8)	1.05 (26.7)	0.62 (15.7)	7300 (502)	3600 (248)
3/4	-PSN-NS12-3	3.00 (76.2)	1.05 (26.7)	0.62 (15.7)	7300 (502)	3600 (248)
3/4	-PSN-NS12-4	4.00 (101.6)	1.05 (26.7)	0.62 (15.7)	7300 (502)	3600 (248)
1	-PSN-NS16-3	3.00 (76.2)	1.31 (33.4)	0.88 (22.4)	5300 (365)	2600 (179)
1	-PSN-NS16-4	4.00 (101.6)	1.31 (33.4)	0.88 (22.4)	5300 (365)	2600 (179)

Adapters

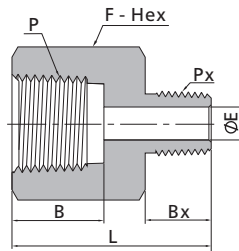

Pipe Fittings
Weld Fittings

Female NPT Threads			Male NPT Threads						
P-NPT Size	Px-NPT Size	Basic Ordering Number	Dimensions, in. (mm)					Working Pressure psig (bar)	
			L	F	B	Bx	E	316 SS, Steel	Brass
1/8	1/16	-PA-NS2-NS1	1.09 (27.7)	0.56 (14.3)	0.41 (10.4)	0.38 (9.7)	0.12 (3.0)	6500 (447)	3200 (220)
1/8	1/8	-PA-NS2	1.10 (27.9)	0.56 (14.3)	0.41 (10.4)	0.38 (9.7)	0.19 (4.8)	6500 (447)	3200 (220)
1/4	1/16	-PA-NS4-NS1	1.20 (30.5)	0.75 (19.1)	0.59 (15.0)	0.38 (9.7)	0.12 (3.0)	6600 (454)	3300 (227)
1/4	1/8	-PA-NS4-NS2	1.26 (32.0)	0.75 (19.1)	0.59 (15.0)	0.38 (9.7)	0.19 (4.8)	6600 (454)	3300 (227)
1/4	1/4	-PA-NS4	1.40 (35.6)	0.75 (19.1)	0.59 (15.0)	0.56 (14.2)	0.28 (7.1)	6600 (454)	3300 (227)
3/8	1/16	-PA-NS6-NS1	1.25 (31.8)	0.87 (22.2)	0.59 (15.0)	0.38 (9.7)	0.12 (3.0)	5300 (365)	2600 (179)
3/8	1/8	-PA-NS6-NS2	1.33 (33.8)	0.87 (22.2)	0.59 (15.0)	0.38 (9.7)	0.19 (4.8)	5300 (365)	2600 (179)
3/8	1/4	-PA-NS6-NS4	1.50 (38.1)	0.87 (22.2)	0.59 (15.0)	0.56 (14.2)	0.28 (7.1)	5300 (365)	2600 (179)
3/8	3/8	-PA-NS6	1.51 (38.4)	0.87 (22.2)	0.59 (15.0)	0.56 (14.2)	0.38 (9.6)	5300 (365)	2600 (179)
1/2	1/8	-PA-NS8-NS2	1.58 (40.1)	1.06 (27.0)	0.78 (19.8)	0.38 (9.7)	0.19 (4.8)	4900 (337)	2400 (165)
1/2	1/4	-PA-NS8-NS4	1.76 (44.7)	1.06 (27.0)	0.78 (19.8)	0.56 (14.2)	0.28 (7.1)	4900 (337)	2400 (165)
1/2	3/8	-PA-NS8-NS6	1.75 (44.4)	1.06 (27.0)	0.78 (19.8)	0.56 (14.2)	0.38 (9.6)	4900 (337)	2400 (165)
1/2	1/2	-PA-NS8	1.94 (49.3)	1.06 (27.0)	0.78 (19.8)	0.75 (19.1)	0.47 (11.9)	4900 (337)	2400 (165)
3/4	1/8	-PA-NS12-NS2	1.56 (39.6)	1.31 (33.3)	0.81 (20.6)	0.38 (9.7)	0.19 (4.8)	4600 (316)	2300 (158)
3/4	1/4	-PA-NS12-NS4	1.85 (47.0)	1.31 (33.3)	0.81 (20.6)	0.56 (14.2)	0.28 (7.1)	4600 (316)	2300 (158)
3/4	3/8	-PA-NS12-NS6	1.82 (46.2)	1.31 (33.3)	0.81 (20.6)	0.56 (14.2)	0.38 (9.6)	4600 (316)	2300 (158)
3/4	1/2	-PA-NS12-NS8	2.02 (51.3)	1.31 (33.3)	0.81 (20.6)	0.75 (19.1)	0.47 (11.9)	4600 (316)	2300 (158)
3/4	3/4	-PA-NS12	2.02 (51.3)	1.31 (33.3)	0.81 (20.6)	0.75 (19.1)	0.62 (15.7)	4600 (316)	2300 (158)
1	1/8	-PA-NS16-NS2	1.81 (46.0)	1.63 (41.3)	1.00 (25.4)	0.38 (9.7)	0.19 (4.8)	4400 (303)	2200 (151)
1	1/4	-PA-NS16-NS4	1.96 (49.8)	1.63 (41.3)	1.00 (25.4)	0.56 (14.2)	0.28 (7.1)	4400 (303)	2200 (151)
1	3/8	-PA-NS16-NS6	2.00 (50.8)	1.63 (41.3)	1.00 (25.4)	0.56 (14.2)	0.38 (9.6)	4400 (303)	2200 (151)
1	1/2	-PA-NS16-NS8	2.16 (54.9)	1.63 (41.3)	1.00 (25.4)	0.75 (19.1)	0.47 (11.9)	4400 (303)	2200 (151)
1	3/4	-PA-NS16-NS12	2.17 (55.1)	1.63 (41.3)	1.00 (25.4)	0.75 (19.1)	0.62 (15.7)	4400 (303)	2200 (151)
1	1	-PA-NS16	2.28 (57.9)	1.63 (41.3)	1.00 (25.4)	0.94 (23.9)	0.88 (22.4)	4400 (303)	2200 (151)
1 1/4	1	-PA-NS20-NS16	2.47 (62.7)	2.13 (54.0)	1.00 (25.4)	0.94 (23.9)	0.88 (22.4)	5000 (344)	2500 (172)

Adapters

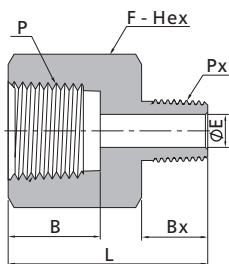

Female NPT Threads			Male ISO Tapered Threads						
P-NPT Size	Px-RT Size	Basic Ordering Number	Dimensions, in. (mm)					Working Pressure psig (bar)	
			L	F	B	Bx	E	316 SS, Steel	Brass
1/8	1/8	-PA-NS2-RT2	1.09 (27.7)	0.56 (14.3)	0.41 (10.4)	0.38 (9.7)	0.19 (4.8)	6500 (447)	3200 (220)
1/4	1/4	-PA-NS4-RT4	1.42 (36.1)	0.75 (19.1)	0.59 (15.0)	0.56 (14.2)	0.28 (7.1)	6600 (454)	3300 (227)
3/8	3/8	-PA-NS6-RT6	1.50 (38.1)	0.87 (22.2)	0.59 (15.0)	0.56 (14.2)	0.38 (9.6)	5300 (365)	2600 (179)
1/2	1/2	-PA-NS8-RT8	1.94 (49.3)	1.06 (27.0)	0.78 (19.8)	0.75 (19.1)	0.47 (11.9)	4900 (337)	2400 (165)
3/4	3/4	-PA-NS12-RT12	2.02 (51.3)	1.31 (33.3)	0.81 (20.6)	0.75 (19.1)	0.62 (15.7)	4600 (316)	2300 (158)
1	1	-PA-NS16-RT16	2.30 (58.4)	1.63 (41.3)	1.00 (25.4)	0.94 (23.9)	0.88 (22.4)	4400 (303)	2200 (151)

Adapters

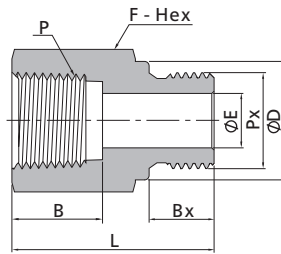

Female NPT Threads			Male ISO Parallel Threads							
P-NPT Size	Px-RS Size	Basic Ordering Number	Dimensions, in. (mm)						Working Pressure psig (bar)	
			L	F	B	Bx	D	E	316 SS, Steel	Brass
1/8	1/8	-PA-NS2-RS2	0.99 (25.1)	0.56 (14.3)	0.39 (9.9)	0.28 (7.1)	0.54 (13.7)	0.16 (4.1)	6500 (447)	3200 (220)
1/4	1/4	-PA-NS4-RS4	1.32 (33.5)	0.75 (19.1)	0.41 (10.4)	0.44 (11.2)	0.71 (18.0)	0.23 (5.8)	6600 (454)	3300 (227)
3/8	3/8	-PA-NS6-RS6	1.41 (35.8)	0.87 (22.2)	0.59 (15.0)	0.44 (11.2)	0.85 (21.6)	0.31 (7.9)	5300 (365)	2600 (179)
1/2	1/2	-PA-NS8-RS8	1.74 (44.2)	1.06 (27.0)	0.59 (15.0)	0.56 (14.2)	1.02 (25.9)	0.47 (11.9)	4900 (337)	2400 (165)
3/4	3/4	-PA-NS12-RS12	1.89 (48.0)	1.31 (33.3)	0.81 (20.6)	0.62 (15.7)	1.26 (32.0)	0.62 (15.7)	4600 (316)	2300 (158)
1	1	-PA-NS16-RS16	2.10 (53.3)	1.63 (41.3)	1.00 (25.4)	0.72 (18.3)	1.53 (38.9)	0.78 (19.8)	4400 (303)	2200 (151)

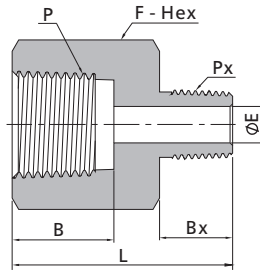

Female ISO Tapered Threads			Male ISO Tapered Threads							
P-RT Size	Px-RT Size	Basic Ordering Number	Dimensions, in. (mm)						Working Pressure psig (bar)	
			L	F	B	Bx	E	316 SS, Steel	Brass	
1/8	1/8	-PA-RT2	1.09 (27.7)	0.56 (14.3)	0.41 (10.4)	0.38 (9.7)	0.19 (4.8)	6500 (447)	3200 (220)	
1/4	1/8	-PA-RT4-RT2	1.26 (32.0)	0.75 (19.1)	0.59 (15.0)	0.38 (9.7)	0.19 (4.8)	6600 (454)	3300 (227)	
1/4	1/4	-PA-RT4	1.42 (36.1)	0.75 (19.1)	0.59 (15.0)	0.56 (14.2)	0.28 (7.1)	6600 (454)	3300 (227)	
3/8	1/4	-PA-RT6-RT4	1.50 (38.1)	0.87 (22.2)	0.59 (15.0)	0.56 (14.2)	0.28 (7.1)	5300 (365)	2600 (179)	
3/8	3/8	-PA-RT6	1.50 (38.1)	0.87 (22.2)	0.59 (15.0)	0.56 (14.2)	0.38 (9.7)	5300 (365)	2600 (179)	
1/2	1/4	-PA-RT8-RT4	1.76 (44.7)	1.06 (27.0)	0.78 (19.8)	0.56 (14.2)	0.28 (7.1)	4900 (337)	2400 (165)	
1/2	3/8	-PA-RT8-RT6	1.75 (44.4)	1.06 (27.0)	0.78 (19.8)	0.56 (14.2)	0.38 (9.7)	4900 (337)	2400 (165)	
1/2	1/2	-PA-RT8	1.95 (49.5)	1.06 (27.0)	0.78 (19.8)	0.75 (19.1)	0.47 (11.9)	4900 (337)	2400 (165)	
3/4	3/4	-PA-RT12	2.02 (51.3)	1.31 (33.3)	0.81 (20.6)	0.75 (19.1)	0.62 (15.7)	4600 (316)	2300 (158)	
1	1	-PA-RT16	2.30 (58.4)	1.63 (41.3)	1.00 (25.4)	0.94 (23.9)	0.88 (22.4)	4400 (303)	2200 (151)	

Adapters

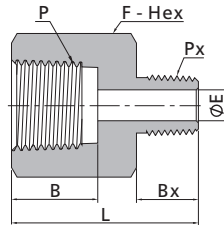

Female ISO Tapered Threads			Male NPT Threads						
P-RT Size	Px-NPT Size	Basic Ordering Number	Dimensions, in. (mm)					Working Pressure psig (bar)	
			L	F	B	Bx	E	316 SS, Steel	Brass
1/8	1/8	-PA-RT2-NS2	1.09 (27.7)	0.56 (14.3)	0.41 (10.4)	0.38 (9.7)	0.19 (4.8)	6500 (447)	3200 (220)
1/4	1/4	-PA-RT4-NS4	1.43 (36.3)	0.75 (19.1)	0.59 (15.0)	0.56 (14.2)	0.28 (7.1)	6600 (454)	3300 (227)
3/8	3/8	-PA-RT6-NS6	1.51 (38.4)	0.87 (22.2)	0.59 (15.0)	0.56 (14.2)	0.38 (9.6)	5300 (365)	2600 (179)
1/2	1/2	-PA-RT8-NS8	1.96 (49.8)	1.06 (27.0)	0.78 (19.8)	0.75 (19.1)	0.47 (11.9)	4900 (337)	2400 (165)
3/4	3/4	-PA-RT12-NS12	2.02 (51.3)	1.31 (33.3)	0.81 (20.6)	0.75 (19.1)	0.62 (15.7)	4600 (316)	2300 (158)
1	1	-PA-RT16-NS16	2.30 (58.4)	1.63 (41.3)	1.00 (25.4)	0.94 (23.9)	0.88 (22.4)	4400 (303)	2200 (151)

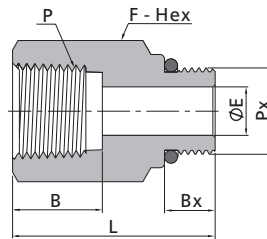

Female NPT Threads			Male SAE/MS Straight Threads					
P-NPT Size	Px-SAE/MS Thread Size	Basic Ordering Number	Dimensions, in. (mm)					Working Pressure psig (bar) 316 SS, Steel
			L	F	B	Bx	E	
1/4	7/16-20	-PA-NS4-ST7	1.32 (33.5)	0.75 (19.1)	0.59 (15.0)	0.36 (9.1)	0.20 (5.1)	4500 (310)
3/8	9/16-18	-PA-NS6-ST9	1.39 (35.3)	0.94 (23.8)	0.59 (15.0)	0.39 (9.9)	0.28 (7.1)	4500 (310)
1/2	3/4-16	-PA-NS8-ST12	1.76 (44.7)	1.06 (27.0)	0.78 (19.8)	0.44 (11.2)	0.42 (10.7)	4500 (310)
3/4	1 1/16-12	-PA-NS12-ST17	1.99 (50.5)	1.37 (34.9)	0.81 (20.6)	0.59 (15.0)	0.66 (16.8)	3600 (248)
1	1 5/16-12	-PA-NS16-ST21	2.12 (53.8)	1.63 (41.3)	1.00 (25.4)	0.59 (15.0)	0.85 (21.5)	2900 (199)

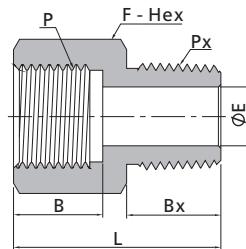

Female ISO Parallel Threads			Male NPT Threads					
P-RG Size	Px-NPT Size	Basic Ordering Number	Dimensions, in. (mm)					Working Pressure psig (bar) 316 SS, Steel
			L	F	B	Bx	E	
1/8	1/8	-PA-RG2-NS2	0.86 (21.8)	0.56 (14.3)	0.26 (6.5)	0.38 (9.7)	0.18 (4.5)	6100 (420)
1/4	1/4	-PA-RG4-NS4	1.19 (30.2)	0.75 (19.1)	0.51 (12.9)	0.56 (14.2)	0.22 (5.5)	5700 (392)
3/8	3/8	-PA-RG6-NS6	1.27 (32.2)	0.94 (23.8)	0.56 (14.2)	0.56 (14.2)	0.26 (6.5)	5700 (392)
1/2	1/2	-PA-RG8-NS8	1.68 (42.7)	1.06 (27.0)	0.74 (18.8)	0.75 (19.1)	0.28 (7.0)	3900 (268)

Reducing Bushings

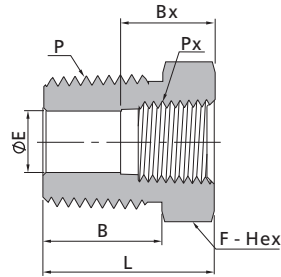

Male NPT Threads			Dimensions, in. (mm)							Female NPT Threads	
P-NPT Size	Px-NPT Size	Basic Ordering Number	L	F	B	Bx	E	Working Pressure psig (bar)			
								316 SS, Steel	Brass		
1/8	1/16	-PRB-NS2-NS1	1.03 (26.2)	0.44 (11.1)	0.38 (9.7)	0.39 (9.9)	0.19 (4.8)	6500 (447)	3200 (220)		
1/4	1/16	-PRB-NS4-NS1	0.86 (21.8)	0.56 (14.3)	0.56 (14.2)	0.39 (9.9)	0.19 (4.8)	8000 (551)	4000 (275)		
1/4	1/8	-PRB-NS4-NS2	1.06 (26.9)	0.56 (14.3)	0.56 (14.2)	0.41 (10.4)	0.28 (7.1)	6500 (447)	3300 (227)		
3/8	1/16	-PRB-NS6-NS1	0.86 (21.8)	0.69 (17.5)	0.56 (14.2)	0.39 (9.9)	0.19 (4.8)	7800 (537)	3900 (268)		
3/8	1/8	-PRB-NS6-NS2	0.86 (21.8)	0.69 (17.5)	0.56 (14.2)	0.41 (10.4)	0.34 (8.6)	7800 (537)	3900 (268)		
3/8	1/4	-PRB-NS6-NS4	1.19 (30.2)	0.75 (19.1)	0.56 (14.2)	0.59 (15.0)	0.38 (9.6)	6600 (454)	3300 (227)		
1/2	1/8	-PRB-NS8-NS2	1.08 (27.4)	0.87 (22.2)	0.75 (19.1)	0.41 (10.4)	0.34 (8.6)	8300 (571)	4400 (303)		
1/2	1/4	-PRB-NS8-NS4	1.08 (27.4)	0.87 (22.2)	0.75 (19.1)	0.59 (15.0)	0.45 (11.4)	8300 (571)	4400 (303)		
1/2	3/8	-PRB-NS8-NS6	1.41 (35.8)	0.87 (22.2)	0.75 (19.1)	0.59 (15.0)	0.47 (11.9)	5300 (365)	2600 (179)		
3/4	1/4	-PRB-NS12-NS4	1.08 (27.4)	1.06 (27.0)	0.75 (19.1)	0.59 (15.0)	0.45 (11.4)	7300 (502)	3600 (248)		
3/4	3/8	-PRB-NS12-NS6	1.08 (27.4)	1.06 (27.0)	0.75 (19.1)	0.59 (15.0)	0.59 (15.0)	7300 (502)	3600 (248)		
3/4	1/2	-PRB-NS12-NS8	1.63 (41.4)	1.06 (27.0)	0.75 (19.1)	0.78 (19.8)	0.62 (15.7)	4900 (337)	2400 (165)		
1	1/4	-PRB-NS16-NS4	1.37 (34.8)	1.37 (34.9)	0.94 (23.9)	0.59 (15.0)	0.45 (11.4)	6500 (447)	3200 (220)		
1	3/8	-PRB-NS16-NS6	1.37 (34.8)	1.37 (34.9)	0.94 (23.9)	0.59 (15.0)	0.59 (15.0)	6500 (447)	3200 (220)		
1	1/2	-PRB-NS16-NS8	1.37 (34.8)	1.37 (34.9)	0.94 (23.9)	0.78 (19.8)	0.73 (18.5)	6500 (447)	3200 (220)		
1	3/4	-PRB-NS16-NS12	1.85 (47.0)	1.37 (34.9)	0.94 (23.9)	0.81 (20.6)	0.88 (22.4)	5300 (365)	2600 (179)		
1 1/4	3/4	-PRB-NS20-NS12	1.47 (37.3)	1.75 (44.5)	0.94 (23.9)	0.81 (20.6)	0.88 (22.4)	6000 (410)	3000 (205)		
1 1/4	1	-PRB-NS20-NS16	1.47 (37.3)	1.75 (44.5)	0.94 (23.9)	1.00 (25.4)	0.88 (22.4)	3500 (241)	1750 (120)		
1 1/2	1	-PRB-NS24-NS16	1.58 (40.1)	2.00 (50.8)	1.03 (26.2)	1.00 (25.4)	0.88 (22.4)	5000 (344)	2500 (172)		
1 1/2	1 1/4	-PRB-NS24-NS20	2.20 (56.0)	2.13 (54.0)	1.03 (26.2)	1.00 (25.4)	1.34 (34.0)	5000 (344)	2500 (172)		

Reducing Bushings

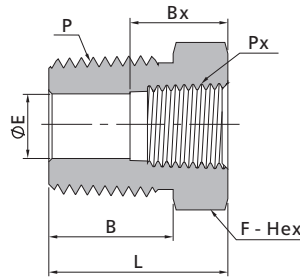

Male NPT Threads			Female ISO Tapered Threads						
P-NPT Size	Px-RT Size	Basic Ordering Number	Dimensions, in. (mm)					Working Pressure psig (bar)	
			L	F	B	Bx	E	316 SS, Steel	Brass
1/8	1/16	-PRB-NS2-RT1	1.03 (26.2)	0.44 (11.1)	0.38 (9.7)	0.39 (9.9)	0.19 (4.8)	6500 (447)	3200 (220)
1/4	1/16	-PRB-NS4-RT1	0.86 (21.8)	0.56 (14.3)	0.56 (14.2)	0.39 (9.9)	0.19 (4.8)	8000 (551)	4000 (275)
1/4	1/8	-PRB-NS4-RT2	1.06 (26.9)	0.56 (14.3)	0.56 (14.2)	0.41 (10.4)	0.28 (7.1)	6500 (447)	3300 (227)
3/8	1/16	-PRB-NS6-RT1	0.86 (21.8)	0.69 (17.5)	0.56 (14.2)	0.39 (9.9)	0.19 (4.8)	7800 (537)	3900 (268)
3/8	1/8	-PRB-NS6-RT2	0.86 (21.8)	0.69 (17.5)	0.56 (14.2)	0.41 (10.4)	0.28 (7.1)	7800 (537)	3900 (268)
3/8	1/4	-PRB-NS6-RT4	1.19 (30.2)	0.75 (19.1)	0.56 (14.2)	0.59 (15.0)	0.38 (9.7)	6600 (454)	3300 (227)
1/2	1/8	-PRB-NS8-RT2	1.08 (27.4)	0.87 (22.2)	0.75 (19.1)	0.41 (10.4)	0.28 (7.1)	8300 (571)	4400 (303)
1/2	1/4	-PRB-NS8-RT4	1.08 (27.4)	0.87 (22.2)	0.75 (19.1)	0.59 (15.0)	0.41 (10.4)	8300 (571)	4400 (303)
1/2	3/8	-PRB-NS8-RT6	1.41 (35.8)	0.87 (22.2)	0.75 (19.1)	0.59 (15.0)	0.47 (11.9)	5300 (365)	2600 (179)
3/4	1/4	-PRB-NS12-RT4	1.08 (27.4)	1.06 (27.0)	0.75 (19.1)	0.59 (15.0)	0.41 (10.4)	7300 (502)	3600 (248)
3/4	3/8	-PRB-NS12-RT6	1.08 (27.4)	1.06 (27.0)	0.75 (19.1)	0.59 (15.0)	0.50 (12.7)	7300 (502)	3600 (248)
3/4	1/2	-PRB-NS12-RT8	1.63 (41.4)	1.06 (27.0)	0.75 (19.1)	0.78 (19.8)	0.62 (15.7)	4900 (337)	2400 (165)
1	1/4	-PRB-NS16-RT4	1.37 (34.8)	1.37 (34.9)	0.94 (23.9)	0.59 (15.0)	0.41 (10.4)	6500 (447)	3200 (220)
1	3/8	-PRB-NS16-RT6	1.37 (34.8)	1.37 (34.9)	0.94 (23.9)	0.59 (15.0)	0.50 (12.7)	6500 (447)	3200 (220)
1	1/2	-PRB-NS16-RT8	1.37 (34.8)	1.37 (34.9)	0.94 (23.9)	0.78 (19.8)	0.62 (15.7)	6500 (447)	3200 (220)
1	3/4	-PRB-NS16-RT12	1.85 (47.0)	1.37 (34.9)	0.94 (23.9)	0.81 (20.6)	0.88 (22.4)	5300 (365)	2600 (179)
1 1/4	3/4	-PRB-NS20-RT12	1.47 (37.3)	1.75 (44.5)	0.94 (23.9)	0.81 (20.6)	0.88 (22.4)	6000 (410)	3000 (205)
1 1/4	1	-PRB-NS20-RT16	1.47 (37.3)	1.75 (44.5)	0.94 (23.9)	1.00 (25.4)	0.88 (22.4)	3500 (241)	1750 (120)
1 1/2	1	-PRB-NS24-RT16	1.58 (40.1)	2.00 (50.8)	1.03 (26.2)	1.00 (25.4)	0.88 (22.4)	5000 (344)	2500 (172)
1 1/2	1 1/4	-PRB-NS24-RT20	2.20 (56.0)	2.13 (54.0)	1.03 (26.2)	1.00 (25.4)	1.34 (34.0)	5000 (344)	2500 (172)

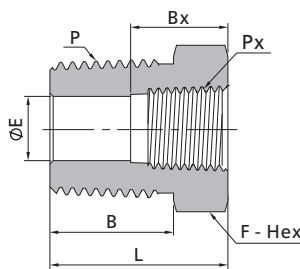

Male ISO Tapered Threads			Female ISO Tapered Threads						
P-RT Size	Px-RT Size	Basic Ordering Number	Dimensions, in. (mm)					Working Pressure psig (bar)	
			L	F	B	Bx	E	316 SS, Steel	Brass
1/4	1/8	-PRB-RT4-RT2	1.06 (26.9)	0.56 (14.3)	0.56 (14.2)	0.41 (10.4)	0.28 (7.1)	6500 (447)	3200 (220)
3/8	1/4	-PRB-RT6-RT4	1.19 (30.2)	0.75 (19.1)	0.56 (14.2)	0.59 (15.0)	0.38 (9.6)	6600 (454)	3300 (227)
1/2	1/4	-PRB-RT8-RT4	1.08 (27.4)	0.87 (22.2)	0.75 (19.1)	0.59 (15.0)	0.44 (11.2)	8300 (571)	4400 (303)
1/2	3/8	-PRB-RT8-RT6	1.41 (35.8)	0.87 (22.2)	0.75 (19.1)	0.59 (15.0)	0.47 (11.9)	5300 (365)	2600 (179)

Reducing Bushings

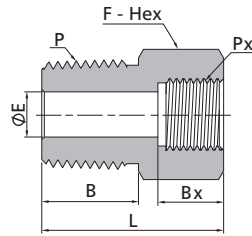

Male NPT Threads			Female ISO Parallel Threads					Working Pressure psig (bar)
P-NPT Size	Px-RG Size	Basic Ordering Number	Dimensions, in. (mm)					
			L	F	B	Bx	E	316 SS, Steel
3/8	1/4	-PRB-NS6-RG4	1.19 (30.2)	0.75 (19.1)	0.56 (14.2)	0.51 (12.9)	0.22 (5.6)	5700 (392)
1/2	3/8	-PRB-NS8-RG6	1.41 (35.8)	0.87 (22.2)	0.75 (19.1)	0.56 (14.2)	0.26 (6.6)	5700 (392)
3/4	1/2	-PRB-NS12-RG8	1.63 (41.4)	1.06 (27.0)	0.75 (19.1)	0.74 (18.8)	0.28 (7.1)	3900 (268)

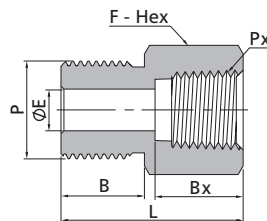

Male ISO Parallel Threads			Female NPT Threads					Working Pressure psig (bar)	
P-BP Size	Px-NPT Size	Basic Ordering Number	Dimensions, in. (mm)					316 SS, Steel	Brass
			L	F	B	Bx	E		
1/4	1/8	-PRB-BP4-NS2	1.06 (26.9)	0.56 (14.3)	0.51 (12.9)	0.41 (10.4)	0.18 (4.5)	6500 (447)	3200 (220)
3/8	1/4	-PRB-BP6-NS4	1.22 (31.0)	0.75 (19.1)	0.56 (14.2)	0.59 (15.0)	0.28 (7.1)	6600 (454)	3300 (227)
1/2	3/8	-PRB-BP8-NS6	1.41 (35.8)	0.87 (22.2)	0.74 (18.8)	0.59 (15.0)	0.26 (6.6)	5300 (365)	2600 (179)

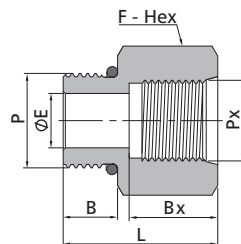

Male SAE/MS Straight Threads			Female SAE/MS Straight Threads					Working Pressure psig (bar)
P-SAE/MS Thread Size	Px-SAE/MS Thread Size	Basic Ordering Number	Dimensions, in. (mm)					
			L	F	B	Bx	E	316 SS, Steel
9/16-18	7/16-20	-PRB-ST9-US7	1.12 (28.4)	0.81 (20.6)	0.39 (9.9)	0.55 (14.0)	0.28 (7.1)	4500 (310)
3/4-16	7/16-20	-PRB-ST12-US7	0.98 (24.9)	0.87 (22.2)	0.44 (11.2)	0.55 (14.0)	0.39 (9.9)	4500 (310)
3/4-16	9/16-18	-PRB-ST12-US9	1.19 (30.2)	1.00 (25.4)	0.44 (11.2)	0.63 (16.0)	0.42 (10.7)	4500 (310)
7/8-14	9/16-18	-PRB-ST14-US9	1.10 (27.9)	1.00 (25.4)	0.50 (12.7)	0.63 (16.0)	0.50 (12.7)	3600 (248)
7/8-14	3/4-16	-PRB-ST14-US12	1.42 (36.1)	1.19 (30.2)	0.50 (12.7)	0.71 (18.0)	0.50 (12.7)	3600 (248)
1 1/16-12	3/4-16	-PRB-ST17-US12	1.27 (32.3)	1.25 (31.8)	0.59 (15.0)	0.71 (18.0)	0.65 (16.5)	3600 (248)
1 5/16-12	1 1/16-12	-PRB-ST21-US17	1.61 (40.9)	1.63 (41.3)	0.59 (15.0)	0.94 (24.0)	0.87 (22.1)	2900 (199)
1 5/8-12	1 5/16-12	-PRB-ST26-US21	1.98 (50.3)	2.13 (54.0)	0.59 (15.0)	0.94 (24.0)	1.09 (27.7)	2300 (158)
1 7/8-12	1 5/16-12	-PRB-ST30-US21	1.27 (32.3)	2.13 (54.0)	0.59 (15.0)	0.94 (24.0)	1.23 (31.2)	2300 (158)

Hex Couplings

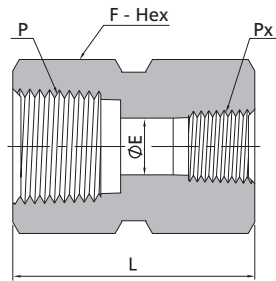

Female NPT Threads								
P-NPT Size	Px-NPT Size	Basic Ordering Number	Dimensions, in. (mm)			Working Pressure psig (bar)		
			L	F	E	316 SS, Steel	Brass	
1/16	1/16	-PCG-NS1	0.78 (19.8)	0.44 (11.1)	0.19 (4.8)	6700 (460)	3300 (227)	
1/8	1/8	-PCG-NS2	0.81 (20.6)	0.56 (14.3)	0.34 (8.6)	6500 (447)	3200 (220)	
1/4	1/8	-PCG-NS4-NS2	1.22 (31.0)	0.75 (19.1)	0.34 (8.6)	6600 (454)	3300 (227)	
1/4	1/4	-PCG-NS4	1.19 (30.2)	0.75 (19.1)	0.45 (11.4)	6600 (454)	3300 (227)	
3/8	1/4	-PCG-NS6-NS4	1.38 (35.1)	0.87 (22.2)	0.45 (11.4)	5300 (365)	2600 (179)	
3/8	3/8	-PCG-NS6	1.31 (33.3)	0.87 (22.2)	0.59 (15.0)	5300 (365)	2600 (179)	
1/2	1/8	-PCG-NS8-NS2	1.56 (39.6)	1.06 (27.0)	0.34 (8.6)	4900 (337)	2400 (165)	
1/2	1/4	-PCG-NS8-NS4	1.75 (44.4)	1.06 (27.0)	0.45 (11.4)	4900 (337)	2400 (165)	
1/2	3/8	-PCG-NS8-NS6	1.78 (45.2)	1.06 (27.0)	0.59 (15.0)	4900 (337)	2400 (165)	
1/2	1/2	-PCG-NS8	1.56 (39.6)	1.06 (27.0)	0.73 (18.5)	4900 (337)	2400 (165)	
3/4	1/4	-PCG-NS12-NS4	1.81 (46.0)	1.31 (33.3)	0.45 (11.4)	4600 (316)	2300 (158)	
3/4	1/2	-PCG-NS12-NS8	2.06 (52.3)	1.31 (33.3)	0.73 (18.5)	4600 (316)	2300 (158)	
3/4	3/4	-PCG-NS12	1.62 (41.1)	1.31 (33.3)	0.94 (23.9)	4600 (316)	2300 (158)	
1	1/2	-PCG-NS16-NS8	2.19 (55.6)	1.63 (41.3)	0.73 (18.5)	4400 (303)	2200 (151)	
1	3/4	-PCG-NS16-NS12	2.25 (57.2)	1.63 (41.3)	0.94 (23.9)	4400 (303)	2200 (151)	
1	1	-PCG-NS16	2.00 (50.8)	1.63 (41.3)	1.17 (29.7)	4400 (303)	2200 (151)	

Female ISO Tapered Threads								
P-RT Size	Px-RT Size	Basic Ordering Number	Dimensions, in. (mm)			Working Pressure psig (bar)		
			L	F	E	316 SS, Steel	Brass	
1/8	1/8	-PCG-RT2	0.81 (20.6)	0.56 (14.3)	0.33 (8.4)	6500 (447)	3200 (220)	
1/4	1/4	-PCG-RT4	1.19 (30.2)	0.75 (19.1)	0.44 (11.2)	6600 (454)	3300 (227)	
3/8	1/4	-PCG-RT6-RT4	1.38 (35.1)	0.87 (22.2)	0.44 (11.2)	5300 (365)	2600 (179)	
3/8	3/8	-PCG-RT6	1.31 (33.3)	0.87 (22.2)	0.58 (14.7)	5300 (365)	2600 (179)	
1/2	1/4	-PCG-RT8-RT4	1.75 (44.4)	1.06 (27.0)	0.44 (11.2)	4900 (337)	2400 (165)	
1/2	3/8	-PCG-RT8-RT6	1.78 (45.2)	1.06 (27.0)	0.58 (14.7)	4900 (337)	2400 (165)	
1/2	1/2	-PCG-RT8	1.56 (39.6)	1.06 (27.0)	0.72 (18.3)	4900 (337)	2400 (165)	

Union Ball Joints

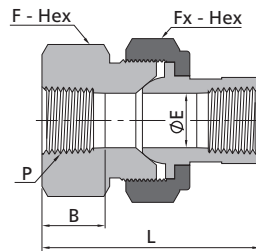

Pipe Fittings
Weld Fittings

Female NPT Threads							
P-NPT Size	Basic Ordering Number	Dimensions, in. (mm)					Working Pressure psig (bar) 316 SS, Steel
		L	F	Fx	B	E	
1/8	-UBJ-NS2	1.81 (46.0)	0.94 (23.8)	1.13 (28.6)	0.41 (10.4)	0.27 (6.8)	8400 (578)
1/4	-UBJ-NS4	2.34 (59.4)	1.19 (30.2)	1.37 (34.9)	0.59 (15.0)	0.36 (9.1)	6600 (454)
3/8	-UBJ-NS6	2.50 (63.5)	1.31 (33.3)	1.50 (38.1)	0.59 (15.0)	0.52 (13.2)	5300 (365)
1/2	-UBJ-NS8	2.69 (68.3)	1.63 (41.3)	1.75 (44.5)	0.78 (19.8)	0.62 (15.7)	6000 (410)
3/4	-UBJ-NS12	3.12 (79.2)	1.87 (47.6)	2.13 (54.0)	0.81 (20.6)	0.88 (22.4)	4600 (316)
1	-UBJ-NS16	3.56 (90.4)	2.37 (60.3)	2.50 (63.5)	1.00 (25.4)	1.03 (26.2)	6800 (468)

Female ISO Tapered Threads							
P-RT Size	Basic Ordering Number	Dimensions, in. (mm)					Working Pressure psig (bar) 316 SS, Steel
		L	F	Fx	B	E	
1/8	-UBJ-RT2	1.81 (46.0)	0.94 (23.8)	1.13 (28.6)	0.41 (10.4)	0.27 (6.8)	8400 (578)
1/4	-UBJ-RT4	2.34 (59.4)	1.19 (30.2)	1.37 (34.9)	0.59 (15.0)	0.36 (9.1)	6600 (454)
3/8	-UBJ-RT6	2.50 (63.5)	1.31 (33.3)	1.50 (38.1)	0.59 (15.0)	0.52 (13.2)	5300 (365)
1/2	-UBJ-RT8	2.69 (68.3)	1.63 (41.3)	1.75 (44.5)	0.78 (19.8)	0.62 (15.7)	6000 (410)
3/4	-UBJ-RT12	3.12 (79.2)	1.87 (47.6)	2.13 (54.0)	0.81 (20.6)	0.88 (22.4)	4600 (316)
1	-UBJ-RT16	3.56 (90.4)	2.37 (60.3)	2.50 (63.5)	1.00 (25.4)	1.03 (26.2)	6800 (468)

Male Elbows

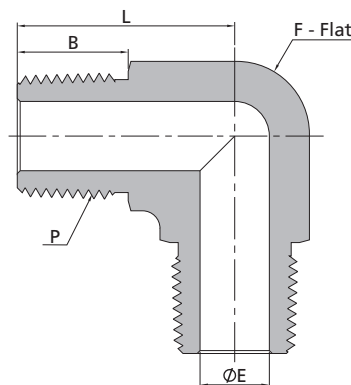

Male NPT Threads							
P-NPT Size	Basic Ordering Number	Dimensions, in. (mm)				Working Pressure psig (bar)	
		L	F	B	E	316 SS, Steel	Brass
1/16	-PME-NS1	0.67 (17.0)	0.37 (9.5)	0.38 (9.7)	0.12 (3.0)	11000 (757)	5500 (378)
1/8	-PME-NS2	0.88 (22.4)	0.44 (11.1)	0.38 (9.7)	0.19 (4.8)	10000 (690)	5000 (344)
1/4	-PME-NS4	1.05 (26.7)	0.50 (12.7)	0.56 (14.2)	0.28 (7.1)	8000 (551)	4000 (275)
3/8	-PME-NS6	1.17 (29.7)	0.69 (17.5)	0.56 (14.2)	0.38 (9.6)	7800 (537)	3900 (268)
1/2	-PME-NS8	1.45 (36.8)	0.81 (20.6)	0.75 (19.1)	0.47 (11.9)	7700 (530)	3800 (261)
3/4	-PME-NS12	1.59 (40.4)	1.06 (27.0)	0.75 (19.1)	0.62 (15.7)	7300 (502)	3600 (248)
1	-PME-NS16	1.97 (50.0)	1.37 (34.9)	0.94 (23.9)	0.88 (22.4)	5300 (365)	2600 (179)

Male ISO Tapered Threads							
P-RT Size	Basic Ordering Number	Dimensions, in. (mm)				Working Pressure psig (bar)	
		L	F	B	E	316 SS, Steel	Brass
1/16	-PME-RT1	0.67 (17.0)	0.37 (9.5)	0.38 (9.7)	0.12 (3.0)	11000 (757)	5500 (378)
1/8	-PME-RT2	0.88 (22.4)	0.44 (11.1)	0.38 (9.7)	0.19 (4.8)	10000 (690)	5000 (344)
1/4	-PME-RT4	1.05 (26.7)	0.50 (12.7)	0.56 (14.2)	0.28 (7.1)	8000 (551)	4000 (275)
3/8	-PME-RT6	1.17 (29.7)	0.69 (17.5)	0.56 (14.2)	0.38 (9.6)	7800 (537)	3900 (268)
1/2	-PME-RT8	1.45 (36.8)	0.81 (20.6)	0.75 (19.1)	0.47 (11.9)	7700 (530)	3800 (261)
3/4	-PME-RT12	1.59 (40.4)	1.06 (27.0)	0.75 (19.1)	0.62 (15.7)	7300 (502)	3600 (248)
1	-PME-RT16	1.97 (50.0)	1.37 (34.9)	0.94 (23.9)	0.88 (22.4)	5300 (365)	2600 (179)

Street Elbows

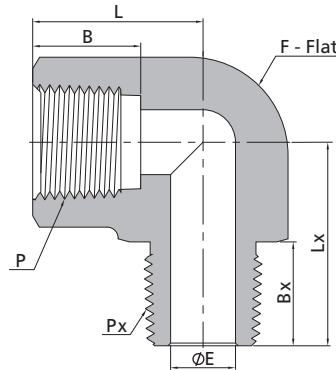

Female NPT Threads			Male NPT Threads							
P-NPT Size	Px-NPT Size	Basic Ordering Number	Dimensions, in. (mm)						Working Pressure psig (bar)	
			L	F	B	E	Lx	Bx	316 SS, Steel	Brass
1/16	1/16	-PSE-NS1	0.86 (21.8)	0.44 (11.1)	0.39 (9.9)	0.12 (3.0)	0.88 (22.4)	0.38 (9.7)	9200 (633)	4600 (316)
1/16	1/8	-PSE-NS1-NS2	0.86 (21.8)	0.44 (11.1)	0.39 (9.9)	0.19 (4.8)	0.88 (22.4)	0.38 (9.7)	9200 (633)	4600 (316)
1/16	1/4	-PSE-NS1-NS4	0.88 (22.4)	0.56 (14.3)	0.39 (9.9)	0.19 (4.8)	1.09 (27.7)	0.56 (14.2)	8000 (551)	4000 (275)
1/16	3/8	-PSE-NS1-NS6	0.88 (22.4)	0.69 (17.5)	0.39 (9.9)	0.19 (4.8)	1.17 (29.7)	0.56 (14.2)	7800 (537)	3900 (268)
1/8	1/16	-PSE-NS2-NS1	1.04 (26.4)	0.50 (12.7)	0.41 (10.4)	0.12 (3.0)	0.87 (22.1)	0.38 (9.7)	6200 (426)	3100 (213)
1/8	1/8	-PSE-NS2	1.04 (26.4)	0.50 (12.7)	0.41 (10.4)	0.19 (4.8)	0.87 (22.1)	0.38 (9.7)	6200 (426)	3100 (213)
1/8	1/4	-PSE-NS2-NS4	0.88 (22.4)	0.56 (14.3)	0.41 (10.4)	0.28 (7.1)	1.09 (27.7)	0.56 (14.2)	6500 (447)	3200 (220)
1/8	3/8	-PSE-NS2-NS6	0.88 (22.4)	0.69 (17.5)	0.41 (10.4)	0.28 (7.1)	1.17 (29.7)	0.56 (14.2)	7800 (537)	3900 (268)
1/8	1/2	-PSE-NS2-NS8	0.95 (24.1)	0.81 (20.6)	0.41 (10.4)	0.28 (7.1)	1.45 (36.8)	0.75 (19.1)	7700 (530)	3800 (261)
1/8	3/4	-PSE-NS2-NS12	1.00 (25.4)	1.06 (27.0)	0.41 (10.4)	0.28 (7.1)	1.59 (40.4)	0.75 (19.1)	7300 (502)	3600 (248)
1/8	1	-PSE-NS2-NS16	1.04 (26.4)	1.37 (34.9)	0.41 (10.4)	0.28 (7.1)	1.97 (50.0)	0.94 (23.9)	5300 (365)	2600 (179)
1/4	1/8	-PSE-NS4-NS2	1.17 (29.7)	0.69 (17.5)	0.59 (15.0)	0.19 (4.8)	1.00 (25.4)	0.38 (9.7)	7200 (496)	3600 (248)
1/4	1/4	-PSE-NS4	1.17 (29.7)	0.69 (17.5)	0.59 (15.0)	0.28 (7.1)	1.17 (29.7)	0.56 (14.2)	7200 (496)	3600 (248)
1/4	3/8	-PSE-NS4-NS6	1.17 (29.7)	0.69 (17.5)	0.59 (15.0)	0.34 (8.6)	1.17 (29.7)	0.56 (14.2)	7200 (496)	3600 (248)
1/4	1/2	-PSE-NS4-NS8	1.00 (25.4)	0.81 (20.6)	0.59 (15.0)	0.34 (8.6)	1.45 (36.8)	0.75 (19.1)	7200 (496)	3600 (248)
1/4	3/4	-PSE-NS4-NS12	1.00 (25.4)	1.06 (27.0)	0.59 (15.0)	0.34 (8.6)	1.59 (40.4)	0.75 (19.1)	7300 (502)	3600 (248)
1/4	1	-PSE-NS4-NS16	1.63 (41.4)	1.37 (34.9)	0.59 (15.0)	0.34 (8.6)	1.97 (50.0)	0.94 (23.9)	5300 (365)	2600 (179)
3/8	1/4	-PSE-NS6-NS4	1.42 (36.1)	0.81 (20.6)	0.59 (15.0)	0.28 (7.1)	1.26 (32.0)	0.56 (14.2)	5600 (385)	2800 (192)
3/8	3/8	-PSE-NS6	1.42 (36.1)	0.81 (20.6)	0.59 (15.0)	0.38 (9.6)	1.26 (32.0)	0.56 (14.2)	5600 (385)	2800 (192)
3/8	1/2	-PSE-NS6-NS8	1.42 (36.1)	0.81 (20.6)	0.59 (15.0)	0.47 (11.9)	1.45 (36.8)	0.75 (19.1)	5600 (385)	2800 (192)
3/8	3/4	-PSE-NS6-NS12	1.23 (31.2)	1.06 (27.0)	0.59 (15.0)	0.47 (11.9)	1.59 (40.4)	0.75 (19.1)	7300 (502)	3600 (248)
3/8	1	-PSE-NS6-NS16	1.63 (41.4)	1.37 (34.9)	0.59 (15.0)	0.47 (11.9)	1.97 (50.0)	0.94 (23.9)	5300 (365)	2600 (179)
1/2	1/4	-PSE-NS8-NS4	1.56 (39.6)	1.00 (25.4)	0.78 (19.8)	0.28 (7.1)	1.38 (35.1)	0.56 (14.2)	5600 (385)	2800 (192)
1/2	3/8	-PSE-NS8-NS6	1.56 (39.6)	1.00 (25.4)	0.78 (19.8)	0.38 (9.6)	1.38 (35.1)	0.56 (14.2)	5600 (385)	2800 (192)
1/2	1/2	-PSE-NS8	1.56 (39.6)	1.00 (25.4)	0.78 (19.8)	0.47 (11.9)	1.56 (39.6)	0.75 (19.1)	5600 (385)	2800 (192)
1/2	3/4	-PSE-NS8-NS12	1.23 (31.2)	1.06 (27.0)	0.78 (19.8)	0.62 (15.7)	1.59 (40.4)	0.75 (19.1)	5600 (385)	2800 (192)
1/2	1	-PSE-NS8-NS16	1.63 (41.4)	1.37 (34.9)	0.78 (19.8)	0.62 (15.7)	1.97 (50.0)	0.94 (23.9)	5300 (365)	2600 (179)
3/4	3/4	-PSE-NS12	1.92 (48.8)	1.25 (31.8)	0.81 (20.6)	0.62 (15.7)	1.67 (42.4)	0.75 (19.1)	5100 (351)	2500 (172)
3/4	1	-PSE-NS12-NS16	1.63 (41.4)	1.37 (34.9)	0.81 (20.6)	0.88 (22.4)	1.97 (50.0)	0.94 (23.9)	5100 (351)	2500 (172)
1	1	-PSE-NS16	1.91 (48.5)	1.69 (42.9)	1.00 (25.4)	0.88 (22.4)	1.94 (49.3)	0.94 (23.9)	5300 (365)	2600 (179)
1 1/4	1 1/4	-PSE-NS20	2.38 (60.5)	2.00 (50.8)	1.00 (25.4)	1.25 (31.8)	2.38 (60.5)	0.94 (23.9)	3100 (213)	1600 (110)

Street Elbows

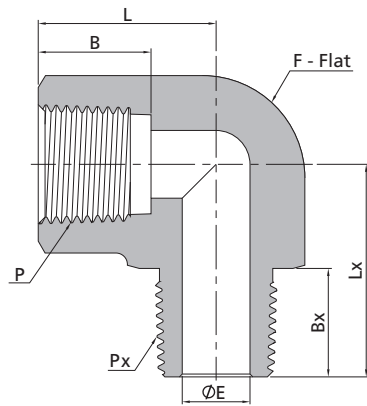

Female ISO Tapered Threads			Male ISO Tapered Threads							
P-RT Size	Px-RT Size	Basic Ordering Number	Dimensions, in. (mm)						Working Pressure psig (bar)	
			L	F	B	E	Lx	Bx	316 SS, Steel	Brass
1/16	1/16	-PSE-RT1	0.86 (21.8)	0.44 (11.1)	0.39 (9.9)	0.12 (3.0)	0.88 (22.4)	0.38 (9.7)	9200 (633)	4600 (316)
1/16	1/8	-PSE-RT1-RT2	0.86 (21.8)	0.44 (11.1)	0.39 (9.9)	0.19 (4.8)	0.88 (22.4)	0.38 (9.7)	9200 (633)	4600 (316)
1/16	1/4	-PSE-RT1-RT4	0.88 (22.4)	0.56 (14.3)	0.39 (9.9)	0.19 (4.8)	1.09 (27.7)	0.56 (14.2)	8000 (551)	4000 (275)
1/16	3/8	-PSE-RT1-RT6	0.88 (22.4)	0.69 (17.5)	0.39 (9.9)	0.19 (4.8)	1.17 (29.7)	0.56 (14.2)	7800 (537)	3900 (268)
1/8	1/16	-PSE-RT2-RT1	1.04 (26.4)	0.50 (12.7)	0.41 (10.4)	0.12 (3.0)	0.87 (22.1)	0.38 (9.7)	6200 (426)	3100 (213)
1/8	1/8	-PSE-RT2	1.04 (26.4)	0.50 (12.7)	0.41 (10.4)	0.19 (4.8)	0.87 (22.1)	0.38 (9.7)	6200 (426)	3100 (213)
1/8	1/4	-PSE-RT2-RT4	0.88 (22.4)	0.56 (14.3)	0.41 (10.4)	0.28 (7.1)	1.09 (27.7)	0.56 (14.2)	6500 (447)	3200 (220)
1/8	3/8	-PSE-RT2-RT6	0.88 (22.4)	0.69 (17.5)	0.41 (10.4)	0.28 (7.1)	1.17 (29.7)	0.56 (14.2)	7800 (537)	3900 (268)
1/8	1/2	-PSE-RT2-RT8	0.95 (24.1)	0.81 (20.6)	0.41 (10.4)	0.28 (7.1)	1.45 (36.8)	0.75 (19.1)	7700 (530)	3800 (261)
1/8	3/4	-PSE-RT2-RT12	1.00 (25.4)	1.06 (27.0)	0.41 (10.4)	0.28 (7.1)	1.59 (40.4)	0.75 (19.1)	7300 (502)	3600 (248)
1/8	1	-PSE-RT2-RT16	1.04 (26.4)	1.37 (34.9)	0.41 (10.4)	0.28 (7.1)	1.97 (50.0)	0.94 (23.9)	5300 (365)	2600 (179)
1/4	1/8	-PSE-RT4-RT2	1.17 (29.7)	0.69 (17.5)	0.59 (15.0)	0.19 (4.8)	1.00 (25.4)	0.38 (9.7)	7200 (496)	3600 (248)
1/4	1/4	-PSE-RT4	1.17 (29.7)	0.69 (17.5)	0.59 (15.0)	0.28 (7.1)	1.17 (29.7)	0.56 (14.2)	7200 (496)	3600 (248)
1/4	3/8	-PSE-RT4-RT6	1.17 (29.7)	0.69 (17.5)	0.59 (15.0)	0.34 (8.6)	1.17 (29.7)	0.56 (14.2)	7200 (496)	3600 (248)
1/4	1/2	-PSE-RT4-RT8	1.00 (25.4)	0.81 (20.6)	0.59 (15.0)	0.34 (8.6)	1.45 (36.8)	0.75 (19.1)	7200 (496)	3600 (248)
1/4	3/4	-PSE-RT4-RT12	1.00 (25.4)	1.06 (27.0)	0.59 (15.0)	0.34 (8.6)	1.59 (40.4)	0.75 (19.1)	7300 (502)	3600 (248)
1/4	1	-PSE-RT4-RT16	1.63 (41.4)	1.37 (34.9)	0.59 (15.0)	0.34 (8.6)	1.97 (50.0)	0.94 (23.9)	5300 (365)	2600 (179)
3/8	1/4	-PSE-RT6-RT4	1.42 (36.1)	0.81 (20.6)	0.59 (15.0)	0.28 (7.1)	1.26 (32.0)	0.56 (14.2)	5600 (385)	2800 (192)
3/8	3/8	-PSE-RT6	1.42 (36.1)	0.81 (20.6)	0.59 (15.0)	0.38 (9.6)	1.26 (32.0)	0.56 (14.2)	5600 (385)	2800 (192)
3/8	1/2	-PSE-RT6-RT8	1.42 (36.1)	0.81 (20.6)	0.59 (15.0)	0.47 (11.9)	1.45 (36.8)	0.75 (19.1)	5600 (385)	2800 (192)
3/8	3/4	-PSE-RT6-RT12	1.23 (31.2)	1.06 (27.0)	0.59 (15.0)	0.47 (11.9)	1.59 (40.4)	0.75 (19.1)	7300 (502)	3600 (248)
3/8	1	-PSE-RT6-RT16	1.63 (41.4)	1.37 (34.9)	0.59 (15.0)	0.47 (11.9)	1.97 (50.0)	0.94 (23.9)	5300 (365)	2600 (179)
1/2	1/4	-PSE-RT8-RT4	1.56 (39.6)	1.00 (25.4)	0.78 (19.8)	0.28 (7.1)	1.38 (35.1)	0.56 (14.2)	5600 (385)	2800 (192)
1/2	3/8	-PSE-RT8-RT6	1.56 (39.6)	1.00 (25.4)	0.78 (19.8)	0.38 (9.6)	1.38 (35.1)	0.56 (14.2)	5600 (385)	2800 (192)
1/2	1/2	-PSE-RT8	1.56 (39.6)	1.00 (25.4)	0.78 (19.8)	0.47 (11.9)	1.56 (39.6)	0.75 (19.1)	5600 (385)	2800 (192)
1/2	3/4	-PSE-RT8-RT12	1.23 (31.2)	1.06 (27.0)	0.78 (19.8)	0.62 (15.7)	1.59 (40.4)	0.75 (19.1)	5600 (385)	2800 (192)
1/2	1	-PSE-RT8-RT16	1.63 (41.4)	1.37 (34.9)	0.78 (19.8)	0.62 (15.7)	1.97 (50.0)	0.94 (23.9)	5300 (365)	2600 (179)
3/4	3/4	-PSE-RT12	1.92 (48.8)	1.25 (31.8)	0.81 (20.6)	0.62 (15.7)	1.67 (42.4)	0.75 (19.1)	5100 (351)	2500 (172)
3/4	1	-PSE-RT12-RT16	1.63 (41.4)	1.37 (34.9)	0.81 (20.6)	0.88 (22.4)	1.97 (50.0)	0.94 (23.9)	5100 (351)	2500 (172)
1	1	-PSE-RT16	1.91 (48.5)	1.69 (42.9)	1.00 (25.4)	0.88 (22.4)	1.94 (49.3)	0.94 (23.9)	5300 (365)	2600 (179)
1 1/4	1 1/4	-PSE-RT20	2.38 (60.5)	2.00 (50.8)	1.00 (25.4)	1.25 (31.8)	2.38 (60.5)	0.94 (23.9)	3100 (213)	1600 (110)

45° Street Elbows

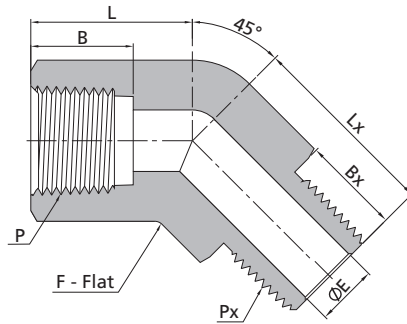

Female NPT Threads			Male NPT Threads							
P-NPT Size	Px-NPT Size	Basic Ordering Number	Dimensions, in. (mm)						Working Pressure psig (bar)	
			L	F	B	E	Lx	Bx	316 SS, Steel	Brass
1/16	1/16	-PSV-NS1	0.66 (16.8)	0.44 (11.1)	0.39 (9.9)	0.12 (3.0)	0.66 (16.8)	0.38 (9.7)	9200 (633)	4600 (316)
1/16	1/8	-PSV-NS1-NS2	0.66 (16.8)	0.44 (11.1)	0.39 (9.9)	0.19 (4.8)	0.66 (16.8)	0.38 (9.7)	9200 (633)	4600 (316)
1/16	1/4	-PSV-NS1-NS4	0.66 (16.8)	0.56 (14.3)	0.39 (9.9)	0.19 (4.8)	0.86 (21.8)	0.56 (14.2)	8000 (551)	4000 (275)
1/16	3/8	-PSV-NS1-NS6	0.88 (22.4)	0.69 (17.5)	0.39 (9.9)	0.19 (4.8)	0.94 (23.8)	0.56 (14.2)	7800 (537)	3900 (268)
1/8	1/16	-PSV-NS2-NS1	0.80 (20.2)	0.50 (12.7)	0.41 (10.4)	0.12 (3.0)	0.68 (17.2)	0.38 (9.7)	6200 (426)	3100 (213)
1/8	1/8	-PSV-NS2	0.80 (20.2)	0.50 (12.7)	0.41 (10.4)	0.19 (4.8)	0.68 (17.2)	0.38 (9.7)	6200 (426)	3100 (213)
1/8	1/4	-PSV-NS2-NS4	0.66 (16.8)	0.56 (14.3)	0.41 (10.4)	0.28 (7.1)	0.86 (21.8)	0.56 (14.2)	6500 (447)	3200 (220)
1/8	3/8	-PSV-NS2-NS6	0.88 (22.4)	0.69 (17.5)	0.41 (10.4)	0.28 (7.1)	0.94 (23.8)	0.56 (14.2)	7800 (537)	3900 (268)
1/8	1/2	-PSV-NS2-NS8	0.87 (22.2)	0.81 (20.6)	0.41 (10.4)	0.28 (7.1)	1.14 (29.0)	0.75 (19.1)	7700 (530)	3800 (261)
1/8	3/4	-PSV-NS2-NS12	1.00 (25.4)	1.06 (27.0)	0.41 (10.4)	0.28 (7.1)	1.20 (30.5)	0.75 (19.1)	7300 (502)	3600 (248)
1/8	1	-PSV-NS2-NS16	1.04 (26.4)	1.37 (34.9)	0.41 (10.4)	0.28 (7.1)	1.94 (49.3)	0.94 (23.9)	5300 (365)	2600 (179)
1/4	1/8	-PSV-NS4-NS2	1.00 (25.4)	0.69 (17.5)	0.59 (15.0)	0.19 (4.8)	0.76 (19.3)	0.38 (9.7)	7200 (496)	3600 (248)
1/4	1/4	-PSV-NS4	1.00 (25.4)	0.69 (17.5)	0.59 (15.0)	0.28 (7.1)	0.76 (19.3)	0.56 (14.2)	7200 (496)	3600 (248)
1/4	3/8	-PSV-NS4-NS6	1.00 (25.4)	0.69 (17.5)	0.59 (15.0)	0.34 (8.6)	0.94 (23.8)	0.56 (14.2)	7200 (496)	3600 (248)
1/4	1/2	-PSV-NS4-NS8	0.87 (22.2)	0.81 (20.6)	0.59 (15.0)	0.34 (8.6)	1.14 (29.0)	0.75 (19.1)	7200 (496)	3600 (248)
1/4	3/4	-PSV-NS4-NS12	1.00 (25.4)	1.06 (27.0)	0.59 (15.0)	0.34 (8.6)	1.20 (30.5)	0.75 (19.1)	7300 (502)	3600 (248)
1/4	1	-PSV-NS4-NS16	1.26 (32.0)	1.37 (34.9)	0.59 (15.0)	0.34 (8.6)	1.48 (37.6)	0.94 (23.9)	5300 (365)	2600 (179)
3/8	1/4	-PSV-NS6-NS4	1.06 (27.0)	0.81 (20.6)	0.59 (15.0)	0.28 (7.1)	0.95 (24.2)	0.56 (14.2)	5600 (385)	2800 (192)
3/8	3/8	-PSV-NS6	1.06 (27.0)	0.81 (20.6)	0.59 (15.0)	0.38 (9.6)	0.95 (24.2)	0.56 (14.2)	5600 (385)	2800 (192)
3/8	1/2	-PSV-NS6-NS8	1.06 (27.0)	0.81 (20.6)	0.59 (15.0)	0.47 (11.9)	1.14 (29.0)	0.75 (19.1)	5600 (385)	2800 (192)
3/8	3/4	-PSV-NS6-NS12	1.06 (27.0)	1.06 (27.0)	0.59 (15.0)	0.47 (11.9)	1.20 (30.5)	0.75 (19.1)	7300 (502)	3600 (248)
3/8	1	-PSV-NS6-NS16	1.26 (32.0)	1.37 (34.9)	0.59 (15.0)	0.47 (11.9)	1.48 (37.6)	0.94 (23.9)	5300 (365)	2600 (179)
1/2	1/4	-PSV-NS8-NS4	1.26 (32.0)	1.00 (25.4)	0.78 (19.8)	0.28 (7.1)	0.99 (25.2)	0.56 (14.2)	5600 (385)	2800 (192)
1/2	3/8	-PSV-NS8-NS6	1.26 (32.0)	1.00 (25.4)	0.78 (19.8)	0.38 (9.6)	0.99 (25.2)	0.56 (14.2)	5600 (385)	2800 (192)
1/2	1/2	-PSV-NS8	1.26 (32.0)	1.00 (25.4)	0.78 (19.8)	0.47 (11.9)	1.26 (32.0)	0.75 (19.1)	5600 (385)	2800 (192)
1/2	3/4	-PSV-NS8-NS12	1.28 (32.5)	1.06 (27.0)	0.78 (19.8)	0.62 (15.7)	1.20 (30.5)	0.75 (19.1)	5600 (385)	2800 (192)
1/2	1	-PSV-NS8-NS16	1.48 (37.6)	1.37 (34.9)	0.78 (19.8)	0.62 (15.7)	1.48 (37.6)	0.94 (23.9)	5300 (365)	2600 (179)
3/4	3/4	-PSV-NS12	1.36 (34.5)	1.25 (31.8)	0.81 (20.6)	0.62 (15.7)	1.36 (34.5)	0.75 (19.1)	5100 (351)	2500 (172)
3/4	1	-PSV-NS12-NS16	1.48 (37.6)	1.37 (34.9)	0.81 (20.6)	0.88 (22.4)	1.48 (37.6)	0.94 (23.9)	5100 (351)	2500 (172)
1	1	-PSV-NS16	1.81 (46.0)	1.69 (42.9)	1.00 (25.4)	0.88 (22.4)	1.81 (46.0)	0.94 (23.9)	5300 (365)	2600 (179)
1 1/4	1 1/4	-PSV-NS20	2.00 (50.8)	2.00 (50.8)	1.00 (25.4)	1.25 (31.8)	2.00 (50.8)	0.94 (23.9)	3100 (213)	1600 (110)

45° Street Elbows

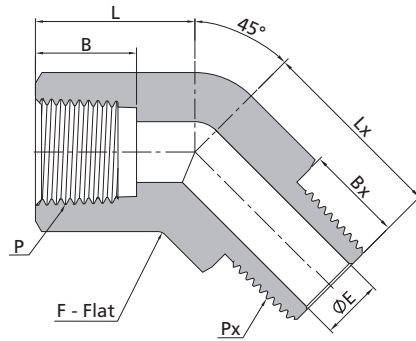

Female ISO Tapered Threads			Male ISO Tapered Threads							
P-RT Size	Px-RT Size	Basic Ordering Number	Dimensions, in. (mm)						Working Pressure psig (bar)	
			L	F	B	E	Lx	Bx	316 SS, Steel	Brass
1/16	1/16	-PSV-RT1	0.66 (16.8)	0.44 (11.1)	0.39 (9.9)	0.12 (3.0)	0.66 (16.8)	0.38 (9.7)	9200 (633)	4600 (316)
1/16	1/8	-PSV-RT1-RT2	0.66 (16.8)	0.44 (11.1)	0.39 (9.9)	0.19 (4.8)	0.66 (16.8)	0.38 (9.7)	9200 (633)	4600 (316)
1/16	1/4	-PSV-RT1-RT4	0.66 (16.8)	0.56 (14.3)	0.39 (9.9)	0.19 (4.8)	0.86 (21.8)	0.56 (14.2)	8000 (551)	4000 (275)
1/16	3/8	-PSV-RT1-RT6	0.88 (22.4)	0.69 (17.5)	0.39 (9.9)	0.19 (4.8)	0.94 (23.8)	0.56 (14.2)	7800 (537)	3900 (268)
1/8	1/16	-PSV-RT2-RT1	0.80 (20.2)	0.50 (12.7)	0.41 (10.4)	0.12 (3.0)	0.68 (17.2)	0.38 (9.7)	6200 (426)	3100 (213)
1/8	1/8	-PSV-RT2	0.80 (20.2)	0.50 (12.7)	0.41 (10.4)	0.19 (4.8)	0.68 (17.2)	0.38 (9.7)	6200 (426)	3100 (213)
1/8	1/4	-PSV-RT2-RT4	0.66 (16.8)	0.56 (14.3)	0.41 (10.4)	0.28 (7.1)	0.86 (21.8)	0.56 (14.2)	6500 (447)	3200 (220)
1/8	3/8	-PSV-RT2-RT6	0.88 (22.4)	0.69 (17.5)	0.41 (10.4)	0.28 (7.1)	0.94 (23.8)	0.56 (14.2)	7800 (537)	3900 (268)
1/8	1/2	-PSV-RT2-RT8	0.87 (22.2)	0.81 (20.6)	0.41 (10.4)	0.28 (7.1)	1.14 (29.0)	0.75 (19.1)	7700 (530)	3800 (261)
1/8	3/4	-PSV-RT2-RT12	1.00 (25.4)	1.06 (27.0)	0.41 (10.4)	0.28 (7.1)	1.20 (30.5)	0.75 (19.1)	7300 (502)	3600 (248)
1/8	1	-PSV-RT2-RT16	1.04 (26.4)	1.37 (34.9)	0.41 (10.4)	0.28 (7.1)	1.94 (49.3)	0.94 (23.9)	5300 (365)	2600 (179)
1/4	1/8	-PSV-RT4-RT2	1.00 (25.4)	0.69 (17.5)	0.59 (15.0)	0.19 (4.8)	0.76 (19.3)	0.38 (9.7)	7200 (496)	3600 (248)
1/4	1/4	-PSV-RT4	1.00 (25.4)	0.69 (17.5)	0.59 (15.0)	0.28 (7.1)	0.76 (19.3)	0.56 (14.2)	7200 (496)	3600 (248)
1/4	3/8	-PSV-RT4-RT6	1.00 (25.4)	0.69 (17.5)	0.59 (15.0)	0.34 (8.6)	0.94 (23.8)	0.56 (14.2)	7200 (496)	3600 (248)
1/4	1/2	-PSV-RT4-RT8	0.87 (22.2)	0.81 (20.6)	0.59 (15.0)	0.34 (8.6)	1.14 (29.0)	0.75 (19.1)	7200 (496)	3600 (248)
1/4	3/4	-PSV-RT4-RT12	1.00 (25.4)	1.06 (27.0)	0.59 (15.0)	0.34 (8.6)	1.20 (30.5)	0.75 (19.1)	7300 (502)	3600 (248)
1/4	1	-PSV-RT4-RT16	1.26 (32.0)	1.37 (34.9)	0.59 (15.0)	0.34 (8.6)	1.48 (37.6)	0.94 (23.9)	5300 (365)	2600 (179)
3/8	1/4	-PSV-RT6-RT4	1.06 (27.0)	0.81 (20.6)	0.59 (15.0)	0.28 (7.1)	0.95 (24.2)	0.56 (14.2)	5600 (385)	2800 (192)
3/8	3/8	-PSV-RT6	1.06 (27.0)	0.81 (20.6)	0.59 (15.0)	0.38 (9.6)	0.95 (24.2)	0.56 (14.2)	5600 (385)	2800 (192)
3/8	1/2	-PSV-RT6-RT8	1.06 (27.0)	0.81 (20.6)	0.59 (15.0)	0.47 (11.9)	1.14 (29.0)	0.75 (19.1)	5600 (385)	2800 (192)
3/8	3/4	-PSV-RT6-RT12	1.06 (27.0)	1.06 (27.0)	0.59 (15.0)	0.47 (11.9)	1.20 (30.5)	0.75 (19.1)	7300 (502)	3600 (248)
3/8	1	-PSV-RT6-RT16	1.26 (32.0)	1.37 (34.9)	0.59 (15.0)	0.47 (11.9)	1.48 (37.6)	0.94 (23.9)	5300 (365)	2600 (179)
1/2	1/4	-PSV-RT8-RT4	1.26 (32.0)	1.00 (25.4)	0.78 (19.8)	0.28 (7.1)	0.99 (25.2)	0.56 (14.2)	5600 (385)	2800 (192)
1/2	3/8	-PSV-RT8-RT6	1.26 (32.0)	1.00 (25.4)	0.78 (19.8)	0.38 (9.6)	0.99 (25.2)	0.56 (14.2)	5600 (385)	2800 (192)
1/2	1/2	-PSV-RT8	1.26 (32.0)	1.00 (25.4)	0.78 (19.8)	0.47 (11.9)	1.26 (32.0)	0.75 (19.1)	5600 (385)	2800 (192)
1/2	3/4	-PSV-RT8-RT12	1.28 (32.5)	1.06 (27.0)	0.78 (19.8)	0.62 (15.7)	1.20 (30.5)	0.75 (19.1)	5600 (385)	2800 (192)
1/2	1	-PSV-RT8-RT16	1.48 (37.6)	1.37 (34.9)	0.78 (19.8)	0.62 (15.7)	1.48 (37.6)	0.94 (23.9)	5300 (365)	2600 (179)
3/4	3/4	-PSV-RT12	1.36 (34.5)	1.25 (31.8)	0.81 (20.6)	0.62 (15.7)	1.36 (34.5)	0.75 (19.1)	5100 (351)	2500 (172)
3/4	1	-PSV-RT12-RT16	1.48 (37.6)	1.37 (34.9)	0.81 (20.6)	0.88 (22.4)	1.48 (37.6)	0.94 (23.9)	5100 (351)	2500 (172)
1	1	-PSV-RT16	1.81 (46.0)	1.69 (42.9)	1.00 (25.4)	0.88 (22.4)	1.81 (46.0)	0.94 (23.9)	5300 (365)	2600 (179)
1 1/4	1 1/4	-PSV-RT20	2.00 (50.8)	2.00 (50.8)	1.00 (25.4)	1.25 (31.8)	2.00 (50.8)	0.94 (23.9)	3100 (213)	1600 (110)

Female Elbows

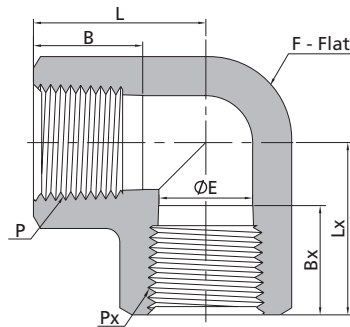

Female NPT Threads

P-NPT Size	Px-NPT Size	Basic Ordering Number	Dimensions, in. (mm)						Working Pressure psig (bar)	
			L	F	B	E	Lx	Bx	316 SS, Steel	Brass
1/16	1/16	-PE-NS1	0.86 (21.8)	0.44 (11.1)	0.39 (9.9)	0.19 (4.8)	0.86 (21.8)	0.39 (9.9)	6700 (460)	3300 (227)
1/8	1/16	-PE-NS2-NS1	1.04 (26.4)	0.50 (12.7)	0.41 (10.4)	0.19 (4.8)	1.04 (26.4)	0.39 (9.9)	6200 (427)	3100 (213)
1/8	1/8	-PE-NS2	1.04 (26.4)	0.50 (12.7)	0.41 (10.4)	0.28 (7.1)	1.04 (26.4)	0.41 (10.4)	6200 (427)	3100 (213)
1/4	1/8	-PE-NS4-NS2	1.17 (29.7)	0.69 (17.5)	0.59 (15.0)	0.28 (7.1)	1.17 (29.7)	0.41 (10.4)	7200 (496)	3600 (248)
1/4	1/4	-PE-NS4	1.17 (29.7)	0.69 (17.5)	0.59 (15.0)	0.41 (10.4)	1.17 (29.7)	0.59 (15.0)	7200 (496)	3600 (248)
3/8	3/8	-PE-NS6	1.42 (36.1)	0.81 (20.6)	0.59 (15.0)	0.50 (12.7)	1.42 (36.1)	0.59 (15.0)	5600 (385)	2800 (192)
1/2	1/2	-PE-NS8	1.56 (39.6)	1.00 (25.4)	0.78 (19.8)	0.67 (17.1)	1.56 (39.6)	0.78 (19.8)	5600 (385)	2800 (192)
3/4	3/4	-PE-NS12	1.92 (48.8)	1.25 (31.8)	0.81 (20.6)	0.88 (22.4)	1.92 (48.8)	0.81 (20.6)	5100 (351)	2500 (172)
1	1	-PE-NS16	1.91 (48.5)	1.69 (42.9)	1.00 (25.4)	1.11 (28.1)	1.91 (48.5)	1.00 (25.4)	6400 (440)	3200 (220)
1 1/4	1 1/4	-PE-NS20	2.35 (59.8)	2.00 (50.8)	1.00 (25.4)	1.09 (27.7)	2.35 (59.8)	1.00 (25.4)	3100 (213)	1600 (110)

Female ISO Tapered Threads

P-RT Size	Px-RT Size	Basic Ordering Number	Dimensions, in. (mm)						Working Pressure psig (bar)	
			L	F	B	E	Lx	Bx	316 SS, Steel	Brass
1/16	1/16	-PE-RT1	0.86 (21.8)	0.44 (11.1)	0.39 (9.9)	0.19 (4.8)	0.86 (21.8)	0.39 (9.9)	6700 (460)	3300 (227)
1/8	1/16	-PE-RT2-RT1	1.04 (26.4)	0.50 (12.7)	0.41 (10.4)	0.19 (4.8)	1.04 (26.4)	0.39 (9.9)	6200 (427)	3100 (213)
1/8	1/8	-PE-RT2	1.04 (26.4)	0.50 (12.7)	0.41 (10.4)	0.28 (7.1)	1.04 (26.4)	0.41 (10.4)	6200 (427)	3100 (213)
1/4	1/8	-PE-RT4-RT2	1.17 (29.7)	0.69 (17.5)	0.59 (15.0)	0.28 (7.1)	1.17 (29.7)	0.41 (10.4)	7200 (496)	3600 (248)
1/4	1/4	-PE-RT4	1.17 (29.7)	0.69 (17.5)	0.59 (15.0)	0.41 (10.4)	1.17 (29.7)	0.59 (15.0)	7200 (496)	3600 (248)
3/8	3/8	-PE-RT6	1.42 (36.1)	0.81 (20.6)	0.59 (15.0)	0.50 (12.7)	1.42 (36.1)	0.59 (15.0)	5600 (385)	2800 (192)
1/2	1/2	-PE-RT8	1.56 (39.6)	1.00 (25.4)	0.78 (19.8)	0.67 (17.1)	1.56 (39.6)	0.78 (19.8)	5600 (385)	2800 (192)
3/4	3/4	-PE-RT12	1.92 (48.8)	1.25 (31.8)	0.81 (20.6)	0.88 (22.4)	1.92 (48.8)	0.81 (20.6)	5100 (351)	2500 (172)
1	1	-PE-RT16	1.91 (48.5)	1.69 (42.9)	1.00 (25.4)	1.11 (28.1)	1.91 (48.5)	1.00 (25.4)	6400 (440)	3200 (220)
1 1/4	1 1/4	-PE-RT20	2.35 (59.8)	2.00 (50.8)	1.00 (25.4)	1.09 (27.7)	2.35 (59.8)	1.00 (25.4)	3100 (213)	1600 (110)

45° Female Elbows

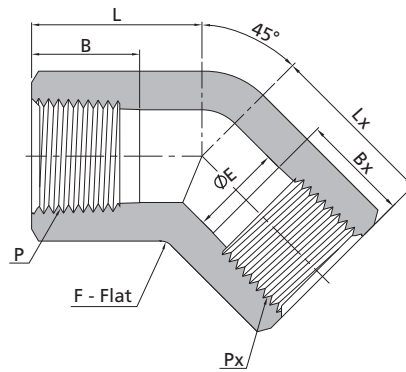

Pipe Fittings
Weld Fittings

Female NPT Threads										
P-NPT Size	Px-NPT Size	Basic Ordering Number	Dimensions, in. (mm)						Working Pressure psig (bar)	
			L	F	B	E	Lx	Bx	316 SS, Steel	Brass
1/16	1/16	-PVE-NS1	0.66 (16.8)	0.44 (11.1)	0.39 (9.9)	0.19 (4.8)	0.66 (16.8)	0.39 (9.9)	6700 (460)	3300 (227)
1/8	1/16	-PVE-NS2-NS1	0.80 (20.2)	0.50 (12.7)	0.41 (10.4)	0.19 (4.8)	0.80 (20.2)	0.39 (9.9)	6200 (427)	3100 (213)
1/8	1/8	-PVE-NS2	0.80 (20.2)	0.50 (12.7)	0.41 (10.4)	0.28 (7.1)	0.80 (20.2)	0.41 (10.4)	6200 (427)	3100 (213)
1/4	1/8	-PVE-NS4-NS2	1.00 (25.4)	0.69 (17.5)	0.59 (15.0)	0.28 (7.1)	1.00 (25.4)	0.41 (10.4)	7200 (496)	3600 (248)
1/4	1/4	-PVE-NS4	1.00 (25.4)	0.69 (17.5)	0.59 (15.0)	0.41 (10.4)	1.00 (25.4)	0.59 (15.0)	7200 (496)	3600 (248)
3/8	3/8	-PVE-NS6	1.06 (27.0)	0.81 (20.6)	0.59 (15.0)	0.50 (12.7)	1.06 (27.0)	0.59 (15.0)	5600 (385)	2800 (192)
1/2	1/2	-PVE-NS8	1.26 (32.0)	1.00 (25.4)	0.78 (19.8)	0.67 (17.1)	1.26 (32.0)	0.78 (19.8)	5600 (385)	2800 (192)
3/4	3/4	-PVE-NS12	1.36 (34.5)	1.25 (31.8)	0.81 (20.6)	0.88 (22.4)	1.36 (34.5)	0.81 (20.6)	5100 (351)	2500 (172)
1	1	-PVE-NS16	2.46 (62.6)	2.00 (50.8)	1.00 (25.4)	1.11 (28.1)	1.81 (46.0)	1.00 (25.4)	6400 (440)	3200 (220)
1 1/4	1 1/4	-PVE-NS20	1.70 (43.2)	2.00 (50.8)	1.00 (25.4)	1.09 (27.7)	1.70 (43.2)	1.00 (25.4)	3100 (213)	1600 (110)

Female ISO Tapered Threads										
P-RT Size	Px-RT Size	Basic Ordering Number	Dimensions, in. (mm)						Working Pressure psig (bar)	
			L	F	B	E	Lx	Bx	316 SS, Steel	Brass
1/16	1/16	-PVE-RT1	0.66 (16.8)	0.44 (11.1)	0.39 (9.9)	0.19 (4.8)	0.66 (16.8)	0.39 (9.9)	6700 (460)	3300 (227)
1/8	1/16	-PVE-RT2-RT1	0.80 (20.2)	0.50 (12.7)	0.41 (10.4)	0.19 (4.8)	0.80 (20.2)	0.39 (9.9)	6200 (427)	3100 (213)
1/8	1/8	-PVE-RT2	0.80 (20.2)	0.50 (12.7)	0.41 (10.4)	0.28 (7.1)	0.80 (20.2)	0.41 (10.4)	6200 (427)	3100 (213)
1/4	1/8	-PVE-RT4-RT2	1.00 (25.4)	0.69 (17.5)	0.59 (15.0)	0.28 (7.1)	1.00 (25.4)	0.41 (10.4)	7200 (496)	3600 (248)
1/4	1/4	-PVE-RT4	1.00 (25.4)	0.69 (17.5)	0.59 (15.0)	0.41 (10.4)	1.00 (25.4)	0.59 (15.0)	7200 (496)	3600 (248)
3/8	3/8	-PVE-RT6	1.06 (27.0)	0.81 (20.6)	0.59 (15.0)	0.50 (12.7)	1.06 (27.0)	0.59 (15.0)	5600 (385)	2800 (192)
1/2	1/2	-PVE-RT8	1.26 (32.0)	1.00 (25.4)	0.78 (19.8)	0.67 (17.1)	1.26 (32.0)	0.78 (19.8)	5600 (385)	2800 (192)
3/4	3/4	-PVE-RT12	1.36 (34.5)	1.25 (31.8)	0.81 (20.6)	0.88 (22.4)	1.36 (34.5)	0.81 (20.6)	5100 (351)	2500 (172)
1	1	-PVE-RT16	2.46 (62.6)	2.00 (50.8)	1.00 (25.4)	1.11 (28.1)	1.81 (46.0)	1.00 (25.4)	6400 (440)	3200 (220)
1 1/4	1 1/4	-PVE-RT20	1.70 (43.2)	2.00 (50.8)	1.00 (25.4)	1.09 (27.7)	1.70 (43.2)	1.00 (25.4)	3100 (213)	1600 (110)

Male Tees

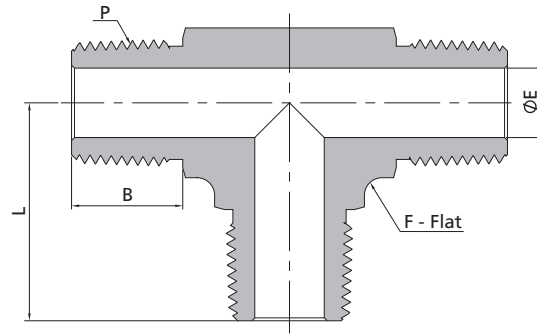

Male NPT Threads

P-NPT Size	Basic Ordering Number	Dimensions, in. (mm)				Working Pressure psig (bar)	
		L	F	B	E	316 SS, Steel	Brass
1/16	-PMT-NS1	0.67 (17.0)	0.37 (9.5)	0.38 (9.7)	0.12 (3.0)	11000 (757)	5500 (378)
1/8	-PMT-NS2	0.88 (22.4)	0.44 (11.1)	0.38 (9.7)	0.19 (4.8)	10000 (690)	5000 (344)
1/4	-PMT-NS4	1.05 (26.7)	0.50 (12.7)	0.56 (14.2)	0.28 (7.1)	8000 (551)	4000 (275)
3/8	-PMT-NS6	1.17 (29.7)	0.69 (17.5)	0.56 (14.2)	0.38 (9.6)	7800 (537)	3900 (268)
1/2	-PMT-NS8	1.45 (36.8)	0.81 (20.6)	0.75 (19.1)	0.47 (11.9)	7700 (530)	3800 (261)
3/4	-PMT-NS12	1.67 (42.4)	1.06 (27.0)	0.75 (19.1)	0.62 (15.7)	7300 (502)	3600 (248)
1	-PMT-NS16	1.94 (49.3)	1.37 (34.9)	0.94 (23.9)	0.88 (22.4)	5300 (365)	2600 (179)

Male ISO Tapered Threads

P-RT Size	Basic Ordering Number	Dimensions, in. (mm)				Working Pressure psig (bar)	
		L	F	B	E	316 SS, Steel	Brass
1/16	-PMT-RT1	0.67 (17.0)	0.37 (9.5)	0.38 (9.7)	0.12 (3.0)	11000 (757)	5500 (378)
1/8	-PMT-RT2	0.88 (22.4)	0.44 (11.1)	0.38 (9.7)	0.19 (4.8)	10000 (690)	5000 (344)
1/4	-PMT-RT4	1.05 (26.7)	0.50 (12.7)	0.56 (14.2)	0.28 (7.1)	8000 (551)	4000 (275)
3/8	-PMT-RT6	1.17 (29.7)	0.69 (17.5)	0.56 (14.2)	0.38 (9.6)	7800 (537)	3900 (268)
1/2	-PMT-RT8	1.45 (36.8)	0.81 (20.6)	0.75 (19.1)	0.47 (11.9)	7700 (530)	3800 (261)
3/4	-PMT-RT12	1.67 (42.4)	1.06 (27.0)	0.75 (19.1)	0.62 (15.7)	7300 (502)	3600 (248)
1	-PMT-RT16	1.94 (49.3)	1.37 (34.9)	0.94 (23.9)	0.88 (22.4)	5300 (365)	2600 (179)

Female Branch Tees

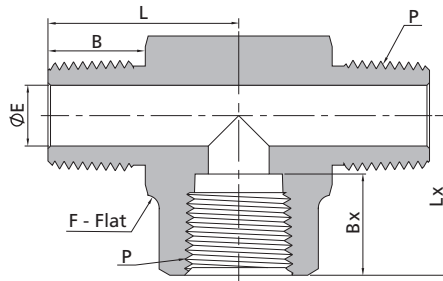

Pipe Fittings
Weld Fittings

NPT Threads		Dimensions, in. (mm)						Working Pressure psig (bar)	
P-NPT Size	Basic Ordering Number	L	F	E	B	Lx	Bx	316 SS, Steel	Brass
		1/16	-PTB-NS1	0.72 (18.3)	0.44 (11.1)	0.12 (3.0)	0.38 (9.7)	0.86 (21.8)	0.39 (9.9)
1/8	-PTB-NS2	0.87 (22.1)	0.50 (12.7)	0.19 (4.8)	0.38 (9.7)	1.04 (26.4)	0.41 (10.4)	6200 (427)	3100 (213)
1/4	-PTB-NS4	1.17 (29.7)	0.69 (17.5)	0.28 (7.1)	0.56 (14.2)	1.17 (29.7)	0.59 (15.0)	7200 (496)	3600 (248)
3/8	-PTB-NS6	1.26 (32.0)	0.81 (20.6)	0.38 (9.6)	0.56 (14.2)	1.42 (36.1)	0.59 (15.0)	5600 (385)	2800 (192)
1/2	-PTB-NS8	1.56 (39.6)	1.00 (25.4)	0.47 (11.9)	0.75 (19.1)	1.56 (39.6)	0.78 (19.8)	5600 (385)	2800 (192)
3/4	-PTB-NS12	1.67 (42.4)	1.25 (31.8)	0.62 (15.7)	0.75 (19.1)	1.92 (48.8)	0.81 (20.6)	5100 (351)	2500 (172)
1	-PTB-NS16	1.94 (49.3)	1.69 (42.9)	0.88 (22.4)	0.94 (23.9)	1.91 (48.5)	1.00 (25.4)	5300 (365)	2600 (179)

ISO Tapered Threads		Dimensions, in. (mm)						Working Pressure psig (bar)	
P-RT Size	Basic Ordering Number	L	F	E	B	Lx	Bx	316 SS, Steel	Brass
		1/16	-PTB-RT1	0.72 (18.3)	0.44 (11.1)	0.12 (3.0)	0.38 (9.7)	0.86 (21.8)	0.39 (9.9)
1/8	-PTB-RT2	0.87 (22.1)	0.50 (12.7)	0.19 (4.8)	0.38 (9.7)	1.04 (26.4)	0.41 (10.4)	6200 (427)	3100 (213)
1/4	-PTB-RT4	1.17 (29.7)	0.69 (17.5)	0.28 (7.1)	0.56 (14.2)	1.17 (29.7)	0.59 (15.0)	7200 (496)	3600 (248)
3/8	-PTB-RT6	1.26 (32.0)	0.81 (20.6)	0.38 (9.6)	0.56 (14.2)	1.42 (36.1)	0.59 (15.0)	5600 (385)	2800 (192)
1/2	-PTB-RT8	1.56 (39.6)	1.00 (25.4)	0.47 (11.9)	0.75 (19.1)	1.56 (39.6)	0.78 (19.8)	5600 (385)	2800 (192)
3/4	-PTB-RT12	1.67 (42.4)	1.25 (31.8)	0.62 (15.7)	0.75 (19.1)	1.92 (48.8)	0.81 (20.6)	5100 (351)	2500 (172)
1	-PTB-RT16	1.94 (49.3)	1.69 (42.9)	0.88 (22.4)	0.94 (23.9)	1.91 (48.5)	1.00 (25.4)	5300 (365)	2600 (179)

Female Run Tees

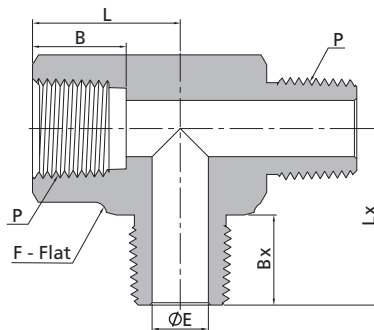

NPT Threads		Dimensions, in. (mm)						Working Pressure psig (bar)	
P-NPT Size	Basic Ordering Number	L	F	E	B	Lx	Bx	316 SS, Steel	Brass
		1/16	-PTR-NS1	0.86 (21.8)	0.44 (11.1)	0.12 (3.0)	0.39 (9.9)	0.72 (18.3)	0.38 (9.7)
1/8	-PTR-NS2	1.04 (26.4)	0.50 (12.7)	0.19 (4.8)	0.41 (10.4)	0.87 (22.1)	0.38 (9.7)	6200 (427)	3100 (213)
1/4	-PTR-NS4	1.17 (29.7)	0.69 (17.5)	0.28 (7.1)	0.59 (15.0)	1.17 (29.7)	0.56 (14.2)	7200 (496)	3600 (248)
3/8	-PTR-NS6	1.42 (36.1)	0.81 (20.6)	0.38 (9.6)	0.59 (15.0)	1.26 (32.0)	0.56 (14.2)	5600 (385)	2800 (192)
1/2	-PTR-NS8	1.56 (39.6)	1.00 (25.4)	0.47 (11.9)	0.78 (19.8)	1.56 (39.6)	0.75 (19.1)	5600 (385)	2800 (192)
3/4	-PTR-NS12	1.92 (48.8)	1.25 (31.8)	0.62 (15.7)	0.81 (20.6)	1.67 (42.4)	0.75 (19.1)	5100 (351)	2500 (172)
1	-PTR-NS16	1.91 (48.5)	1.69 (42.9)	0.88 (22.4)	1.00 (25.4)	1.94 (49.3)	0.94 (23.9)	5300 (365)	2600 (179)

ISO Tapered Threads									
P-RT Size	Basic Ordering Number	Dimensions, in. (mm)						Working Pressure psig (bar)	
		L	F	E	B	Lx	Bx	316 SS, Steel	Brass
1/16	-PTR-RT1	0.86 (21.8)	0.44 (11.1)	0.12 (3.0)	0.39 (9.9)	0.72 (18.3)	0.38 (9.7)	9200 (633)	4600 (316)
1/8	-PTR-RT2	1.04 (26.4)	0.50 (12.7)	0.19 (4.8)	0.41 (10.4)	0.87 (22.1)	0.38 (9.7)	6200 (427)	3100 (213)
1/4	-PTR-RT4	1.17 (29.7)	0.69 (17.5)	0.28 (7.1)	0.59 (15.0)	1.17 (29.7)	0.56 (14.2)	7200 (496)	3600 (248)
3/8	-PTR-RT6	1.42 (36.1)	0.81 (20.6)	0.38 (9.6)	0.59 (15.0)	1.26 (32.0)	0.56 (14.2)	5600 (385)	2800 (192)
1/2	-PTR-RT8	1.56 (39.6)	1.00 (25.4)	0.47 (11.9)	0.78 (19.8)	1.56 (39.6)	0.75 (19.1)	5600 (385)	2800 (192)
3/4	-PTR-RT12	1.92 (48.8)	1.25 (31.8)	0.62 (15.7)	0.81 (20.6)	1.67 (42.4)	0.75 (19.1)	5100 (351)	2500 (172)
1	-PTR-RT16	1.91 (48.5)	1.69 (42.9)	0.88 (22.4)	1.00 (25.4)	1.94 (49.3)	0.94 (23.9)	5300 (365)	2600 (179)

Male Street Tees

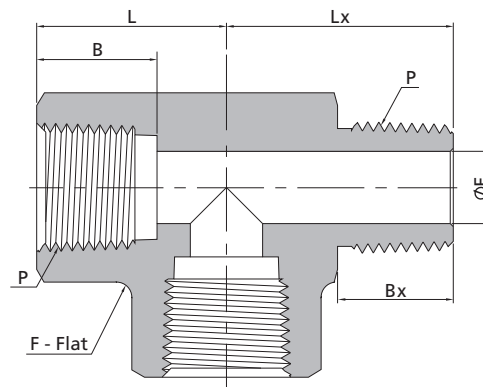

NPT Threads									
P-NPT Size	Basic Ordering Number	Dimensions, in. (mm)						Working Pressure psig (bar)	
		L	F	E	B	Lx	Bx	316 SS, Steel	Brass
1/16	-PST-NS1	0.86 (21.8)	0.44 (11.1)	0.12 (3.0)	0.39 (9.9)	0.72 (18.3)	0.38 (9.7)	9200 (633)	4600 (316)
1/8	-PST-NS2	1.04 (26.4)	0.50 (12.7)	0.19 (4.8)	0.41 (10.4)	0.87 (22.1)	0.38 (9.7)	6200 (427)	3100 (213)
1/4	-PST-NS4	1.17 (29.7)	0.69 (17.5)	0.28 (7.1)	0.59 (15.0)	1.17 (29.7)	0.56 (14.2)	7200 (496)	3600 (248)
3/8	-PST-NS6	1.42 (36.1)	0.81 (20.6)	0.38 (9.6)	0.59 (15.0)	1.26 (32.0)	0.56 (14.2)	5600 (385)	2800 (192)
1/2	-PST-NS8	1.56 (39.6)	1.00 (25.4)	0.47 (11.9)	0.78 (19.8)	1.56 (39.6)	0.75 (19.1)	5600 (385)	2800 (192)
3/4	-PST-NS12	1.92 (48.8)	1.25 (31.8)	0.62 (15.7)	0.81 (20.6)	1.67 (42.4)	0.75 (19.1)	5100 (351)	2500 (172)
1	-PST-NS16	1.91 (48.5)	1.69 (42.9)	0.88 (22.4)	1.00 (25.4)	1.94 (49.3)	0.94 (23.9)	5300 (365)	2600 (179)

ISO Tapered Threads									
P-RT Size	Basic Ordering Number	Dimensions, in. (mm)						Working Pressure psig (bar)	
		L	F	E	B	Lx	Bx	316 SS, Steel	Brass
1/16	-PST-RT1	0.86 (21.8)	0.44 (11.1)	0.12 (3.0)	0.39 (9.9)	0.72 (18.3)	0.38 (9.7)	9200 (633)	4600 (316)
1/8	-PST-RT2	1.04 (26.4)	0.50 (12.7)	0.19 (4.8)	0.41 (10.4)	0.87 (22.1)	0.38 (9.7)	6200 (427)	3100 (213)
1/4	-PST-RT4	1.17 (29.7)	0.69 (17.5)	0.28 (7.1)	0.59 (15.0)	1.17 (29.7)	0.56 (14.2)	7200 (496)	3600 (248)
3/8	-PST-RT6	1.42 (36.1)	0.81 (20.6)	0.38 (9.6)	0.59 (15.0)	1.26 (32.0)	0.56 (14.2)	5600 (385)	2800 (192)
1/2	-PST-RT8	1.56 (39.6)	1.00 (25.4)	0.47 (11.9)	0.78 (19.8)	1.56 (39.6)	0.75 (19.1)	5600 (385)	2800 (192)
3/4	-PST-RT12	1.92 (48.8)	1.25 (31.8)	0.62 (15.7)	0.81 (20.6)	1.67 (42.4)	0.75 (19.1)	5100 (351)	2500 (172)
1	-PST-RT16	1.91 (48.5)	1.69 (42.9)	0.88 (22.4)	1.00 (25.4)	1.94 (49.3)	0.94 (23.9)	5300 (365)	2600 (179)

Male Branch Tees

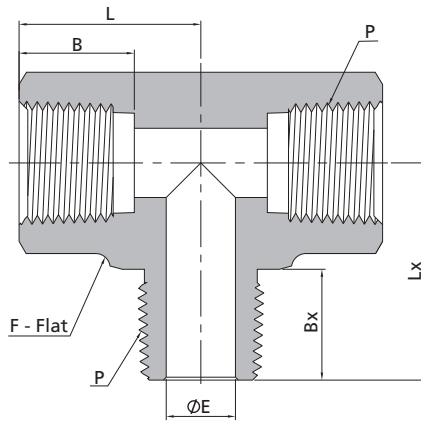

NPT Threads		Dimensions, in. (mm)						Working Pressure psig (bar)	
P-NPT Size	Basic Ordering Number	L	F	E	B	Lx	Bx	316 SS, Steel	Brass
		1/16	-PBT-NS1	0.86 (21.8)	0.44 (11.1)	0.12 (3.0)	0.39 (9.9)	0.72 (18.3)	0.38 (9.7)
1/8	-PBT-NS2	1.04 (26.4)	0.50 (12.7)	0.19 (4.8)	0.41 (10.4)	0.87 (22.1)	0.38 (9.7)	6200 (427)	3100 (213)
1/4	-PBT-NS4	1.17 (29.7)	0.69 (17.5)	0.28 (7.1)	0.59 (15.0)	1.17 (29.7)	0.56 (14.2)	7200 (496)	3600 (248)
3/8	-PBT-NS6	1.42 (36.1)	0.81 (20.6)	0.38 (9.6)	0.59 (15.0)	1.26 (32.0)	0.56 (14.2)	5600 (385)	2800 (192)
1/2	-PBT-NS8	1.56 (39.6)	1.00 (25.4)	0.47 (11.9)	0.78 (19.8)	1.56 (39.6)	0.75 (19.1)	5600 (385)	2800 (192)
3/4	-PBT-NS12	1.92 (48.8)	1.25 (31.8)	0.62 (15.7)	0.81 (20.6)	1.67 (42.4)	0.75 (19.1)	5100 (351)	2500 (172)
1	-PBT-NS16	1.91 (48.5)	1.69 (42.9)	0.88 (22.4)	1.00 (25.4)	1.94 (49.3)	0.94 (23.9)	5300 (365)	2600 (179)

ISO Tapered Threads		Dimensions, in. (mm)						Working Pressure psig (bar)	
P-RT Size	Basic Ordering Number	L	F	E	B	Lx	Bx	316 SS, Steel	Brass
		1/16	-PBT-RT1	0.86 (21.8)	0.44 (11.1)	0.12 (3.0)	0.39 (9.9)	0.72 (18.3)	0.38 (9.7)
1/8	-PBT-RT2	1.04 (26.4)	0.50 (12.7)	0.19 (4.8)	0.41 (10.4)	0.87 (22.1)	0.38 (9.7)	6200 (427)	3100 (213)
1/4	-PBT-RT4	1.17 (29.7)	0.69 (17.5)	0.28 (7.1)	0.59 (15.0)	1.17 (29.7)	0.56 (14.2)	7200 (496)	3600 (248)
3/8	-PBT-RT6	1.42 (36.1)	0.81 (20.6)	0.38 (9.6)	0.59 (15.0)	1.26 (32.0)	0.56 (14.2)	5600 (385)	2800 (192)
1/2	-PBT-RT8	1.56 (39.6)	1.00 (25.4)	0.47 (11.9)	0.78 (19.8)	1.56 (39.6)	0.75 (19.1)	5600 (385)	2800 (192)
3/4	-PBT-RT12	1.92 (48.8)	1.25 (31.8)	0.62 (15.7)	0.81 (20.6)	1.67 (42.4)	0.75 (19.1)	5100 (351)	2500 (172)
1	-PBT-RT16	1.91 (48.5)	1.69 (42.9)	0.88 (22.4)	1.00 (25.4)	1.94 (49.3)	0.94 (23.9)	5300 (365)	2600 (179)

Female Tees

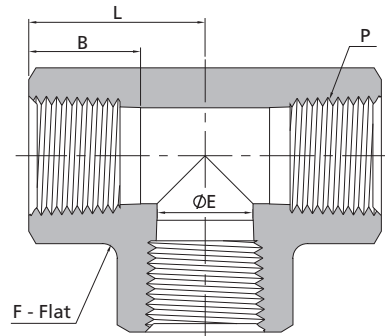

Female NPT Threads							
P-NPT Size	Basic Ordering Number	Dimensions, in. (mm)				Working Pressure psig (bar)	
		L	F	E	B	316 SS, Steel	Brass
1/16	-PT-NS1	0.86 (21.8)	0.44 (11.1)	0.19 (4.8)	0.39 (9.9)	6700 (460)	3300 (227)
1/8	-PT-NS2	1.04 (26.4)	0.50 (12.7)	0.34 (8.6)	0.41 (10.4)	6200 (427)	3100 (213)
1/4	-PT-NS4	1.17 (29.7)	0.69 (17.5)	0.45 (11.4)	0.59 (15.0)	7200 (496)	3600 (248)
3/8	-PT-NS6	1.42 (36.1)	0.81 (20.6)	0.59 (15.0)	0.59 (15.0)	5600 (385)	2800 (192)
1/2	-PT-NS8	1.56 (39.6)	1.00 (25.4)	0.73 (18.5)	0.78 (19.8)	5600 (385)	2800 (192)
3/4	-PT-NS12	1.92 (48.8)	1.25 (31.8)	0.94 (23.9)	0.81 (20.6)	5100 (351)	2500 (172)
1	-PT-NS16	1.91 (48.5)	1.69 (42.9)	1.17 (29.7)	1.00 (25.4)	6400 (440)	3200 (220)
1 1/4	-PT-NS20	2.35 (59.8)	2.00 (50.8)	1.46 (37.2)	1.00 (25.4)	3100 (213)	1600 (110)
1 1/2	-PT-NS24	2.56 (65.0)	2.50 (63.5)	1.70 (43.3)	1.09 (27.7)	5100 (351)	2500 (172)

Female ISO Tapered Threads							
P-RT Size	Basic Ordering Number	Dimensions, in. (mm)				Working Pressure psig (bar)	
		L	F	E	B	316 SS, Steel	Brass
1/16	-PT-RT1	0.86 (21.8)	0.44 (11.1)	0.19 (4.8)	0.39 (9.9)	6700 (460)	3300 (227)
1/8	-PT-RT2	1.04 (26.4)	0.50 (12.7)	0.34 (8.6)	0.41 (10.4)	6200 (427)	3100 (213)
1/4	-PT-RT4	1.17 (29.7)	0.69 (17.5)	0.44 (11.2)	0.59 (15.0)	7200 (496)	3600 (248)
3/8	-PT-RT6	1.42 (36.1)	0.81 (20.6)	0.58 (14.7)	0.59 (15.0)	5600 (385)	2800 (192)
1/2	-PT-RT8	1.56 (39.6)	1.00 (25.4)	0.72 (18.3)	0.78 (19.8)	5600 (385)	2800 (192)
3/4	-PT-RT12	1.92 (48.8)	1.25 (31.8)	0.94 (23.9)	0.81 (20.6)	5100 (351)	2500 (172)
1	-PT-RT16	1.91 (48.5)	1.69 (42.9)	1.17 (29.7)	1.00 (25.4)	6400 (440)	3200 (220)
1 1/4	-PT-RT20	2.35 (59.8)	2.00 (50.8)	1.46 (37.2)	1.00 (25.4)	3100 (213)	1600 (110)
1 1/2	-PT-RT24	2.56 (65.0)	2.50 (63.5)	1.70 (43.3)	1.09 (27.7)	5100 (351)	2500 (172)

Female Crosses

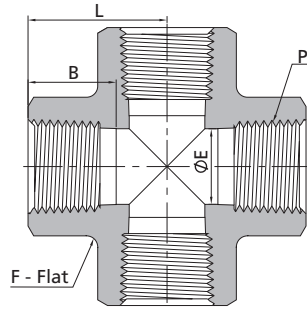

Pipe Fittings
Weld Fittings

Female NPT Threads							
P-NPT Size	Basic Ordering Number	Dimensions, in. (mm)				Working Pressure psig (bar)	
		L	F	E	B	316 SS, Steel	Brass
1/16	-PCR-NS1	0.86 (21.8)	0.44 (11.1)	0.19 (4.8)	0.39 (9.9)	6700 (460)	3300 (227)
1/8	-PCR-NS2	1.04 (26.4)	0.50 (12.7)	0.34 (8.6)	0.41 (10.4)	6200 (427)	3100 (213)
1/4	-PCR-NS4	1.17 (29.7)	0.69 (17.5)	0.45 (11.4)	0.59 (15.0)	7200 (496)	3600 (248)
3/8	-PCR-NS6	1.42 (36.1)	0.81 (20.6)	0.59 (15.0)	0.59 (15.0)	5600 (385)	2800 (192)
1/2	-PCR-NS8	1.56 (39.6)	1.00 (25.4)	0.73 (18.5)	0.78 (19.8)	5600 (385)	2800 (192)
3/4	-PCR-NS12	1.92 (48.8)	1.25 (31.8)	0.94 (23.9)	0.81 (20.6)	5100 (351)	2500 (172)
1	-PCR-NS16	1.91 (48.5)	1.69 (42.9)	1.17 (29.7)	1.00 (25.4)	6400 (440)	3200 (220)

Female ISO Tapered Threads							
P-RT Size	Basic Ordering Number	Dimensions, in. (mm)				Working Pressure psig (bar)	
		L	F	E	B	316 SS, Steel	Brass
1/16	-PCR-RT1	0.86 (21.8)	0.44 (11.1)	0.19 (4.8)	0.39 (9.9)	6700 (460)	3300 (227)
1/8	-PCR-RT2	1.04 (26.4)	0.50 (12.7)	0.34 (8.6)	0.41 (10.4)	6200 (427)	3100 (213)
1/4	-PCR-RT4	1.17 (29.7)	0.69 (17.5)	0.45 (11.4)	0.59 (15.0)	7200 (496)	3600 (248)
3/8	-PCR-RT6	1.42 (36.1)	0.81 (20.6)	0.59 (15.0)	0.59 (15.0)	5600 (385)	2800 (192)
1/2	-PCR-RT8	1.56 (39.6)	1.00 (25.4)	0.73 (18.5)	0.78 (19.8)	5600 (385)	2800 (192)
3/4	-PCR-RT12	1.92 (48.8)	1.25 (31.8)	0.94 (23.9)	0.81 (20.6)	5100 (351)	2500 (172)
1	-PCR-RT16	1.91 (48.5)	1.69 (42.9)	1.17 (29.7)	1.00 (25.4)	6400 (440)	3200 (220)

Pipe to Pipe Unions

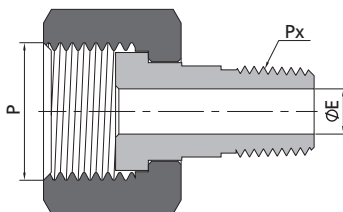

Metric Threads			NPT Threads	
P-Metric Thread Size	Px-NPT Size	Basic Ordering Number	Dimensions, in. (mm)	Working Pressure psig (bar)
			E	316 SS, Steel
M20 x 1.5	1/8	-PUP-MS20-NS2	0.19 (4.8)	4500 (310)
M20 x 1.5	1/4	-PUP-MS20-NS4	0.28 (7.1)	4500 (310)

Metric Threads			ISO Tapered Threads	
P-Metric Thread Size	Px-RT Size	Basic Ordering Number	Dimensions, in. (mm)	Working Pressure psig (bar)
			E	316 SS, Steel
M20 x 1.5	1/8	-PUP-MS20-RT2	0.19 (4.8)	4500 (310)
M20 x 1.5	1/4	-PUP-MS20-RT4	0.28 (7.1)	4500 (310)

ISO Parallel Threads			NPT Threads		
P-ISO Pipe Size	Px- NPT Size	Basic Ordering Number	Dimensions, in. (mm)		Working Pressure psig (bar) 316 SS, Steel
			E		
1/2	1/8	-PUP-RG8-NS2	0.19 (4.8)		4900 (337)
1/2	1/4	-PUP-RG8-NS4	0.28 (7.1)		4900 (337)

Hand Tight Adapter Fittings

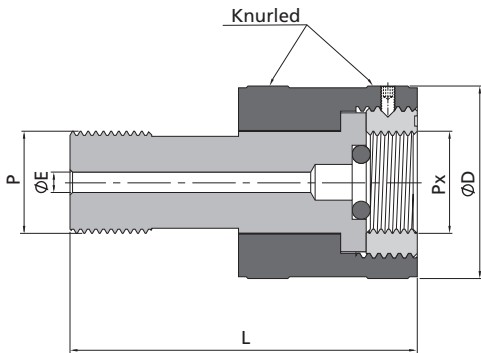

Metric Threads						
P-Metric Thread Size	Px-Metric Thread Size	Basic Ordering Number	Dimensions, mm (in.)			Working Pressure psig (bar) 316 SS, Steel
			L	D	E	
M14 x 1.5	M14 x 1.5	-HF-MS14	58.0 (2.28)	27.0 (1.06)	3.2 (0.13)	6100 (425)
M14 x 1.5	M20 x 1.5	-HF-MS14-MS20	58.0 (2.28)	37.5 (1.48)	3.2 (0.13)	5700 (393)
M20 x 1.5	M14 x 1.5	-HF-MS20-MS14	68.0 (2.68)	32.0 (1.26)	4.0 (0.16)	6100 (425)
M20 x 1.5	M20 x 1.5	-HF-MS20	68.0 (2.68)	37.5 (1.48)	4.0 (0.16)	5700 (393)
M20 x 1.5	M22 x 1.5	-HF-MS20-MS22	68.0 (2.68)	37.5 (1.48)	4.0 (0.16)	4000 (275)

Metric Threads			ISO Parallel Threads			
P-Metric Thread Size	Px-ISO Thread Size	Basic Ordering Number	Dimensions, mm (in.)			Working Pressure psig (bar) 316 SS, Steel
			L	D	E	
M20 x 1.5	1/4	-HF-MS20-RG4	68.0 (2.68)	32.0 (1.26)	3.2 (0.13)	6500 (447)
M20 x 1.5	3/8	-HF-MS20-RG6	68.0 (2.68)	32.0 (1.26)	3.6 (0.14)	4300 (297)
M20 x 1.5	1/2	-HF-MS20-RG8	68.0 (2.68)	37.5 (1.48)	4.0 (0.16)	4800 (334)

ISO Parallel Threads						
P-ISO Thread Size	Px-ISO Thread Size	Basic Ordering Number	Dimensions, mm (in.)			Working Pressure psig (bar) 316 SS, Steel
			L	D	E	
1/2	1/4	-HF-BP8-RG4	68.0 (2.68)	32.0 (1.26)	3.2 (0.13)	6500 (447)
1/2	3/8	-HF-BP8-RG6	68.0 (2.68)	32.0 (1.26)	3.6 (0.14)	4300 (297)
1/2	1/2	-HF-BP8-RG8	68.0 (2.68)	37.5 (1.48)	4.0 (0.16)	4800 (334)

Pipe Plugs

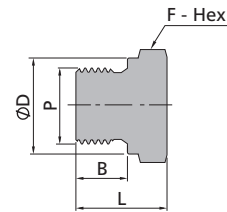
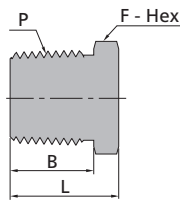

Male NPT Threads

P-NPT Size	Basic Ordering Number	Dimensions, in. (mm)		
		L	F	B
1/16	-PP-NS1	0.56 (14.2)	0.31 (7.9)	0.38 (9.7)
1/8	-PP-NS2	0.56 (14.2)	0.44 (11.1)	0.38 (9.7)
1/4	-PP-NS4	0.75 (19.1)	0.56 (14.3)	0.56 (14.2)
3/8	-PP-NS6	0.78 (19.8)	0.69 (17.5)	0.56 (14.2)
1/2	-PP-NS8	0.97 (24.6)	0.87 (22.2)	0.75 (19.1)
3/4	-PP-NS12	1.21 (30.7)	1.06 (27.0)	0.75 (19.1)
1	-PP-NS16	1.50 (38.1)	1.37 (34.9)	0.94 (23.9)
1 1/4	-PP-NS20	1.51 (38.4)	1.75 (44.5)	0.94 (23.9)
1 1/2	-PP-NS24	1.72 (43.7)	2.00 (50.8)	1.03 (26.2)
2	-PP-NS32	2.00 (50.8)	2.75 (69.9)	1.03 (26.2)

Male ISO Parallel Threads

P-RS Size	Basic Ordering Number	Dimensions, in. (mm)			
		L	F	B	D
1/8	-PP-RS2	0.55 (14.0)	0.56 (14.3)	0.28 (7.1)	0.54 (13.7)
1/4	-PP-RS4	0.78 (19.8)	0.75 (19.1)	0.44 (11.2)	0.71 (18.0)
3/8	-PP-RS6	0.78 (19.8)	0.87 (22.2)	0.44 (11.2)	0.86 (21.8)
1/2	-PP-RS8	0.99 (25.1)	1.06 (27.0)	0.55 (14.0)	1.02 (25.9)
3/4	-PP-RS12	1.13 (28.7)	1.31 (33.3)	0.62 (15.7)	1.26 (32.0)
1	-PP-RS16	1.21 (30.7)	1.63 (41.3)	0.71 (18.0)	1.54 (39.1)

Male Metric Threads

P-Metric Size	Basic Ordering Number	Dimensions, mm (in.)			
		L	F	B	D
M14 x 1.5	-PP-MRS14	21.0 (0.83)	20.6 (0.81)	12.0 (0.47)	18.8 (0.74)
M16 x 1.5	-PP-MRS16	23.0 (0.91)	22.2 (0.87)	12.0 (0.47)	20.8 (0.82)
M18 x 1.5	-PP-MRS18	25.0 (0.98)	23.8 (0.94)	12.0 (0.47)	22.8 (0.90)
M20 x 1.5	-PP-MRS20	26.5 (1.04)	25.4 (1.00)	14.0 (0.55)	24.8 (0.98)
M22 x 1.5	-PP-MRS22	28.8 (1.13)	28.6 (1.13)	14.0 (0.55)	26.8 (1.06)
M24 x 1.5	-PP-MRS24	29.0 (1.14)	35.0 (1.38)	14.0 (0.55)	28.8 (1.13)
M27 x 2	-PP-MRS27	30.0 (1.18)	36.5 (1.44)	16.0 (0.63)	31.8 (1.25)

Male ISO Tapered Threads

P-RT Size	Basic Ordering Number	Dimensions, in. (mm)		
		L	F	B
1/16	-PP-RT1	0.56 (14.2)	0.31 (7.9)	0.38 (9.7)
1/8	-PP-RT2	0.56 (14.2)	0.44 (11.1)	0.38 (9.7)
1/4	-PP-RT4	0.75 (19.1)	0.56 (14.3)	0.56 (14.2)
3/8	-PP-RT6	0.78 (19.8)	0.69 (17.5)	0.56 (14.2)
1/2	-PP-RT8	0.97 (24.6)	0.87 (22.2)	0.75 (19.1)
3/4	-PP-RT12	1.21 (30.7)	1.06 (27.0)	0.75 (19.1)
1	-PP-RT16	1.50 (38.1)	1.37 (34.9)	0.94 (23.9)
1 1/4	-PP-RT20	1.51 (38.4)	1.75 (44.5)	0.94 (23.9)
1 1/2	-PP-RT24	1.72 (43.7)	2.00 (50.8)	1.03 (26.2)
2	-PP-RT32	2.00 (50.8)	2.75 (69.9)	1.03 (26.2)

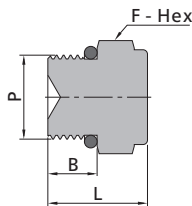
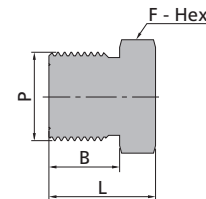

Male SAE/MS Straight Threads

P-SAE/MS Thread Size	Basic Ordering Number	Dimensions, in. (mm)		
		L	F	B
7/16-20	-PP-ST7	0.76 (19.3)	0.56 (14.3)	0.36 (9.1)
9/16-18	-PP-ST9	0.82 (20.8)	0.69 (17.5)	0.39 (9.9)
3/4-16	-PP-ST12	0.89 (22.6)	0.87 (22.2)	0.44 (11.2)
1 1/16-12	-PP-ST17	1.12 (28.4)	1.25 (31.8)	0.59 (15.0)
1 5/16-12	-PP-ST21	1.18 (30.0)	1.50 (38.1)	0.59 (15.0)

Male Metric Threads

P-Metric Size	Basic Ordering Number	Dimensions, mm (in.)		
		L	F	B
M14 x 1.5	-PP-MS14	18.0 (0.71)	16.0 (0.63)	13.0 (0.51)
M16 x 1.5	-PP-MS16	20.0 (0.79)	18.0 (0.71)	14.0 (0.55)
M18 x 1.5	-PP-MS18	22.0 (0.87)	19.0 (0.75)	15.0 (0.59)
M20 x 1.5	-PP-MS20	24.0 (0.94)	22.0 (0.87)	16.0 (0.63)
M22 x 1.5	-PP-MS22	26.0 (1.02)	24.0 (0.94)	17.0 (0.67)
M24 x 1.5	-PP-MS24	26.0 (1.02)	27.0 (1.06)	17.0 (0.67)
M27 x 2	-PP-MS27	27.0 (1.06)	30.0 (1.18)	18.0 (0.71)
M30 x 2	-PP-MS30	32.0 (1.26)	32.0 (1.26)	20.0 (0.79)

Dimensions are for reference only, subject to change.

Hollow Hex Plugs

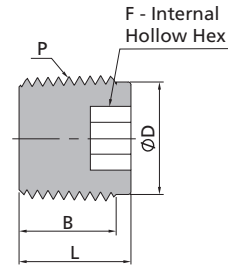
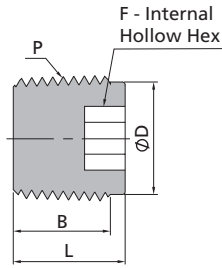

Pipe Fittings
Weld Fittings

Male NPT Threads

P-NPT Size	Basic Ordering Number	Dimensions, in. (mm)			
		L	F	B	D
1/16	-PI-NS1	0.30 (7.6)	0.16 (4.0)	0.29 (7.4)	0.29 (7.4)
1/8	-PI-NS2	0.41 (10.4)	0.19 (4.8)	0.29 (7.4)	0.37 (9.4)
1/4	-PI-NS4	0.61 (15.5)	0.25 (6.4)	0.49 (12.4)	0.48 (12.1)
3/8	-PI-NS6	0.59 (15.0)	0.31 (7.9)	0.47 (11.9)	0.62 (15.7)
1/2	-PI-NS8	0.76 (19.3)	0.37 (9.5)	0.64 (16.2)	0.76 (19.3)
3/4	-PI-NS12	0.78 (19.8)	0.56 (14.3)	0.66 (16.7)	1.01 (25.7)
1	-PI-NS16	0.82 (20.8)	0.63 (15.9)	0.70 (17.7)	1.25 (31.8)

Male ISO Tapered Threads

P-RT Size	Basic Ordering Number	Dimensions, in. (mm)			
		L	F	B	D
1/16	-PI-RT1	0.30 (7.6)	0.16 (4.0)	0.29 (7.4)	0.29 (7.4)
1/8	-PI-RT2	0.41 (10.4)	0.19 (4.8)	0.29 (7.4)	0.37 (9.4)
1/4	-PI-RT4	0.61 (15.5)	0.25 (6.4)	0.49 (12.4)	0.48 (12.1)
3/8	-PI-RT6	0.61 (15.5)	0.31 (7.9)	0.49 (12.4)	0.62 (15.7)
1/2	-PI-RT8	0.76 (19.3)	0.37 (9.5)	0.64 (16.2)	0.76 (19.3)
3/4	-PI-RT12	0.78 (19.8)	0.56 (14.3)	0.66 (16.7)	1.01 (25.7)
1	-PI-RT16	0.82 (20.8)	0.63 (15.9)	0.70 (17.7)	1.25 (31.8)

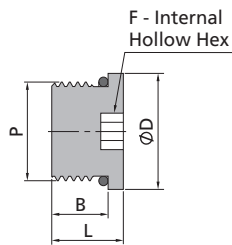

Male SAE/MS Straight Threads

P-SAE/MS Thread Size	Basic Ordering Number	Dimensions, in. (mm)			
		L	F	B	D
7/16-20	-PI-ST7	0.45 (11.4)	0.19 (4.8)	0.36 (9.1)	0.56 (14.2)
9/16-18	-PI-ST9	0.48 (12.2)	0.25 (6.4)	0.39 (9.9)	0.69 (17.5)
3/4-16	-PI-ST12	0.56 (14.2)	0.31 (7.9)	0.44 (11.2)	0.88 (22.4)
1 1/16-12	-PI-ST17	0.75 (19.1)	0.56 (14.3)	0.59 (15.0)	1.25 (31.8)
1 5/16-12	-PI-ST21	0.75 (19.1)	0.63 (15.9)	0.59 (15.0)	1.50 (38.1)

Pipe Caps

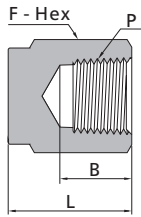

Pipe Fittings
Weld Fittings

Female NPT Threads						
P-NPT Size	Basic Ordering Number	Dimensions, in. (mm)			Working Pressure psig (bar)	
		L	F	B	316 SS, Steel	Brass
1/16	-PC-NS1	0.50 (12.7)	0.44 (11.1)	0.39 (9.9)	6700 (460)	3300 (227)
1/8	-PC-NS2	0.75 (19.1)	0.56 (14.3)	0.41 (10.4)	6500 (447)	3200 (220)
1/4	-PC-NS4	0.91 (23.1)	0.75 (19.1)	0.59 (15.0)	6600 (454)	3300 (277)
3/8	-PC-NS6	1.03 (26.2)	0.87 (22.2)	0.59 (15.0)	5300 (365)	2600 (179)
1/2	-PC-NS8	1.34 (34.0)	1.06 (27.0)	0.78 (19.8)	4900 (337)	2400 (165)
3/4	-PC-NS12	1.44 (36.6)	1.31 (33.3)	0.81 (20.6)	4600 (316)	2300 (158)
1	-PC-NS16	1.62 (41.1)	1.63 (41.3)	1.00 (25.4)	4400 (303)	2200 (151)

Female ISO Tapered Threads						
P-RT Size	Basic Ordering Number	Dimensions, in. (mm)			Working Pressure psig (bar)	
		L	F	B	316 SS, Steel	Brass
1/16	-PC-RT1	0.50 (12.7)	0.44 (11.1)	0.39 (9.9)	6700 (460)	3300 (227)
1/8	-PC-RT2	0.75 (19.1)	0.56 (14.3)	0.41 (10.4)	6500 (447)	3200 (220)
1/4	-PC-RT4	0.91 (23.1)	0.75 (19.1)	0.59 (15.0)	6600 (454)	3300 (277)
3/8	-PC-RT6	1.03 (26.2)	0.87 (22.2)	0.59 (15.0)	5300 (365)	2600 (179)
1/2	-PC-RT8	1.34 (34.0)	1.06 (27.0)	0.78 (19.8)	4900 (337)	2400 (165)
3/4	-PC-RT12	1.44 (36.6)	1.31 (33.3)	0.81 (20.6)	4600 (316)	2300 (158)
1	-PC-RT16	1.62 (41.1)	1.63 (41.3)	1.00 (25.4)	4400 (303)	2200 (151)

Ordering Number Description

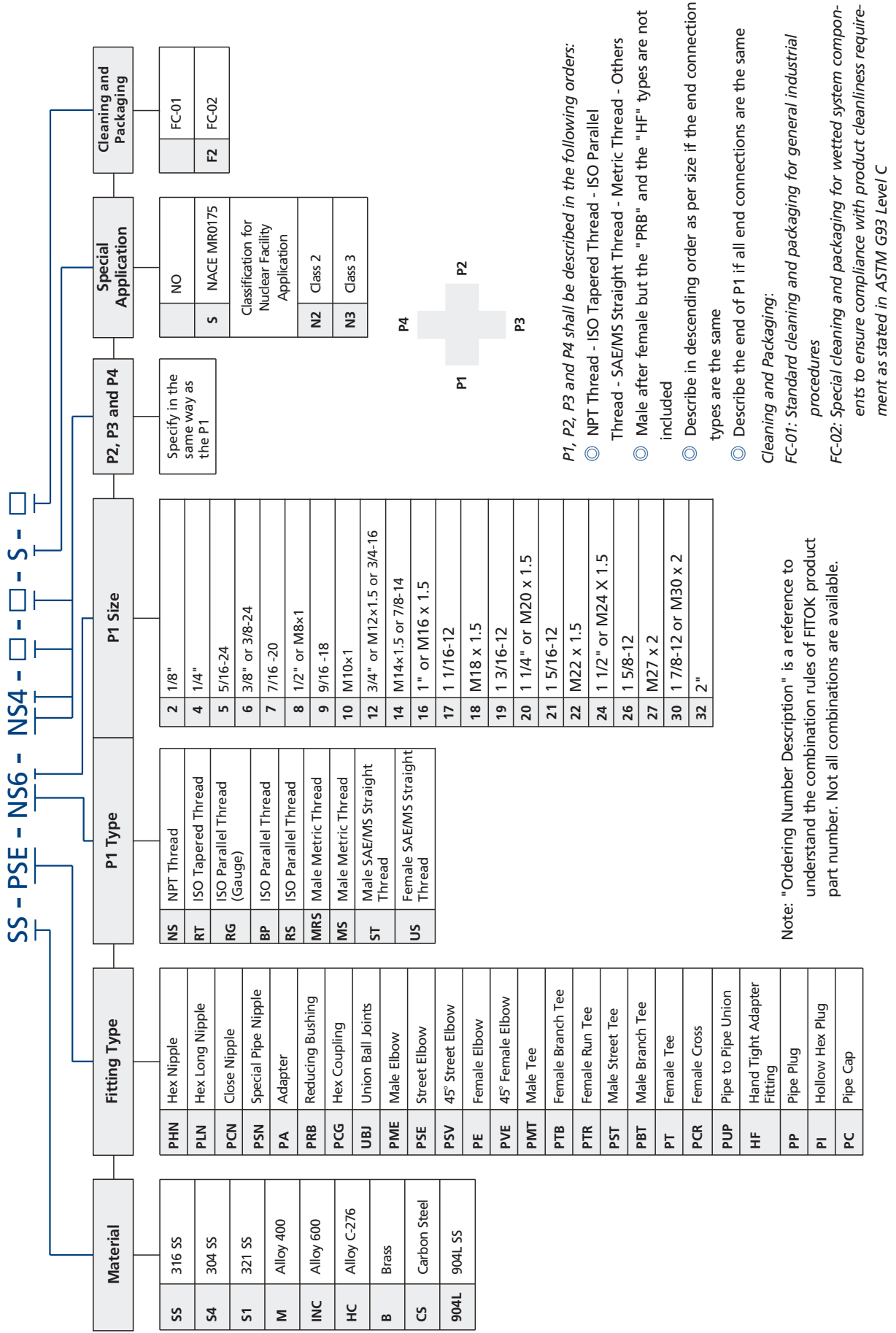

info@fitokgroup.com
www.fitokgroup.com

FK-IC-GF-02-EN-191226

6 Series Weld Fittings



Contents

Tube Butt Weld Fittings

Male Connectors - WM



A-147

Female Connectors - WF



A-148

Reducing Unions - WU



A-148

Union Elbows - WLU



A-149

Union Tees - WT

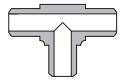

A-149

Union Crosses - WC

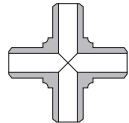

A-150

Tube Socket Weld Fittings

Male Connectors - WM



A-150

Female Connectors - WF



A-151

Male Elbows - WLM



A-151

Female Elbows - WLF



A-152

Unions - WU



A-153

Reducing Unions - WU



A-153

Union Elbows - WLU



A-153

Union 45° Elbows - WV



A-154

Union Tees - WT

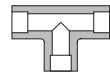

A-154

Union Crosses - WC

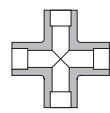

A-155

Pipe Butt Weld Fittings

Male Connectors - WM



A-155

Female Connectors - WF



A-156

Pipe Socket Weld Fittings

Male Connectors - WM



A-156

Female Connectors - WF



A-156

Unions - WU



A-157

Weld Adapters

Tube Butt Weld to Tube Socket Weld - WA



A-157

Pipe Butt Weld to Tube Socket Weld - WA



A-157

Pipe to Weld Fittings

Pipe to Tube Butt Weld - PUW

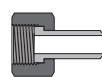

A-158

Male Pipe to Tube Butt Weld - MUW

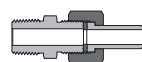

A-159

Ordering Number Description

A-160

Features

- ⦿ 316 stainless steel as standard material. Other materials are available upon request
- ⦿ Straight fittings are manufactured from quality bar stock. Shaped fittings are made by forging
- ⦿ Quality machining of all ports ensures consistent welding
- ⦿ Radius junction design for elbows provides smooth flow path
- ⦿ All fittings are cleaned to remove oil, grease and loose particles
- ⦿ Every fitting is marked with size, material and heat number

Technical Data

- ⦿ Sizes range from 1/8" to 2" and 6 mm to 38 mm.
- ⦿ Working Temperature:

Material	Minimum Temperature	Maximum Temperature
316 stainless steel	-325°F (-198°C)	1000°F (538°C)
316L stainless steel	-325°F (-198°C)	850°F (454°C)
904L stainless steel	-325°F (-198°C)	700°F (371°C)

- ⦿ Working Pressure:

1. The working pressures shown are based on ANSI/ASME B31.3 at ambient temperature, to determine working pressures in accordance with ANSI/ASME B31.1, multiply the working pressures by 0.94.
2. Use the allowable working pressure at ambient temperature to multiply the elevated temperature factors to get the working pressure at elevated temperature. To know the elevated temperature factor, please see F-14.

Materials

Material	Bar Stock	Forgings	Designator
316 stainless steel	ASTM A276, ASME SA479	ASTM A182, ASME SA182	SS
316L stainless steel			6L
904L stainless steel	ASTM B649	ASTM A182	904L

- ⦿ *Using the same materials to weld will ensure the same coefficients of expansion and good welding.*
- ⦿ *Tungsten Inert Gas (TIG) Welding is recommended.*

Tube Butt Weld Fittings

Male Connectors

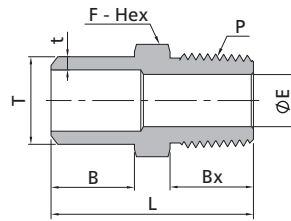

Fractional Tube				NPT Thread					
T-Tube O.D. (in.)	t-Wall Thickness (in.)	P-NPT Size	Basic Ordering Number	Dimensions, in. (mm)					Working Pressure psig (bar)
				L	B	Bx	F	E	
1/4	0.065	1/4	-WM-TB4-NS4	1.17 (29.7)	0.38 (9.7)	0.56 (14.2)	0.56 (14.3)	0.28 (7.1)	8000 (551)
1/4	0.065	1/2	-WM-TB4-NS8	1.45 (36.8)	0.38 (9.7)	0.75 (19.1)	0.87 (22.2)	0.47 (11.9)	7700 (530)
3/8	0.095	1/4	-WM-TB6-NS4	1.17 (29.7)	0.38 (9.7)	0.56 (14.2)	0.56 (14.3)	0.28 (7.1)	8000 (551)
3/8	0.095	1/2	-WM-TB6-NS8	1.45 (36.8)	0.38 (9.7)	0.75 (19.1)	0.87 (22.2)	0.47 (11.9)	7700 (530)
1/2	0.095	1/4	-WM-TB8-NS4	1.35 (34.3)	0.56 (14.2)	0.56 (14.2)	0.56 (14.3)	0.28 (7.1)	6780 (468)
1/2	0.095	1/2	-WM-TB8-NS8	1.63 (41.4)	0.56 (14.2)	0.75 (19.1)	0.87 (22.2)	0.47 (11.9)	6780 (468)
5/8	0.109	1/4	-WM-TB10-NS4	1.37 (34.8)	0.56 (14.2)	0.56 (14.2)	0.69 (17.5)	0.28 (7.1)	5760 (397)
5/8	0.109	1/2	-WM-TB10-NS8	1.63 (41.4)	0.56 (14.2)	0.75 (19.1)	0.87 (22.2)	0.47 (11.9)	5760 (397)
3/4	0.120	1/4	-WM-TB12-NS4	1.58 (40.1)	0.75 (19.1)	0.56 (14.2)	0.81 (20.6)	0.28 (7.1)	5530 (381)
3/4	0.120	1/2	-WM-TB12-NS8	1.82 (46.2)	0.75 (19.1)	0.75 (19.1)	0.87 (22.2)	0.47 (11.9)	5530 (381)
1	0.134	1/4	-WM-TB16-NS4	1.69 (42.9)	0.75 (19.1)	0.56 (14.2)	1.06 (27.0)	0.28 (7.1)	4480 (309)
1	0.134	1/2	-WM-TB16-NS8	1.88 (47.8)	0.75 (19.1)	0.75 (19.1)	1.06 (27.0)	0.47 (11.9)	4480 (309)

Metric Tube				NPT Thread					
T-Tube O.D. (mm)	t-Wall Thickness (mm)	P-NPT Size	Basic Ordering Number	Dimensions, mm (in.)					Working Pressure psig (bar)
				L	B	Bx	F	E	
12	2.2	1/4	-WM-MTB12-NS4	34.3 (1.35)	14.2 (0.56)	14.2 (0.56)	14.0 (0.55)	7.1 (0.28)	6470 (446)
12	2.2	1/2	-WM-MTB12-NS8	41.1 (1.62)	14.2 (0.56)	19.1 (0.75)	22.0 (0.87)	11.9 (0.47)	6470 (446)
14	2.5	1/4	-WM-MTB14-NS4	34.3 (1.35)	14.2 (0.56)	14.2 (0.56)	15.0 (0.59)	7.1 (0.28)	6280 (433)
14	2.5	1/2	-WM-MTB14-NS8	41.4 (1.63)	14.2 (0.56)	19.1 (0.75)	22.0 (0.87)	11.9 (0.47)	6280 (433)
15	2.5	1/4	-WM-MTB15-NS4	34.8 (1.37)	14.2 (0.56)	14.2 (0.56)	16.0 (0.63)	7.1 (0.28)	5770 (398)
16	2.8	1/4	-WM-MTB16-NS4	35.6 (1.40)	14.2 (0.56)	14.2 (0.56)	18.0 (0.71)	7.1 (0.28)	6140 (423)
16	2.8	1/2	-WM-MTB16-NS8	41.1 (1.62)	14.2 (0.56)	19.1 (0.75)	22.0 (0.87)	11.9 (0.47)	6140 (423)
20	3.0	1/2	-WM-MTB20-NS8	46.2 (1.82)	19.1 (0.75)	19.1 (0.75)	22.0 (0.87)	11.9 (0.47)	5110 (352)
22	3.0	1/4	-WM-MTB22-NS4	41.2 (1.62)	19.1 (0.75)	14.2 (0.56)	24.0 (0.94)	7.1 (0.28)	4620 (319)
22	3.0	1/2	-WM-MTB22-NS8	46.1 (1.81)	19.1 (0.75)	19.1 (0.75)	24.0 (0.94)	11.9 (0.47)	4620 (319)
25	3.5	3/4	-WM-MTB25-NS12	47.8 (1.88)	19.1 (0.75)	19.1 (0.75)	27.0 (1.06)	15.7 (0.62)	4730 (326)
25	3.5	1	-WM-MTB25-NS16	54.9 (2.16)	19.1 (0.75)	23.9 (0.94)	35.0 (1.38)	22.4 (0.88)	4730 (326)
28	4.0	1/2	-WM-MTB28-NS8	54.2 (2.13)	21.4 (0.84)	19.1 (0.75)	30.0 (1.18)	11.9 (0.47)	4850 (335)

Dimensions are for reference only, subject to change.

Female Connectors

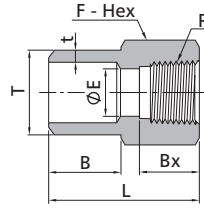

Pipe Fittings
Weld Fittings

Fractional Tube				Dimensions, in. (mm)					NPT Thread	Working Pressure psig (bar)
T-Tube O.D. (in.)	t-Wall Thickness (in.)	P-NPT Size	Basic Ordering Number	L	B	Bx	F	E		
1/4	0.065	1/4	-WF-TB4-NS4	1.10 (27.9)	0.38 (9.7)	0.59 (15.0)	0.75 (19.1)	0.12 (3.0)	6600 (454)	
1/4	0.065	3/8	-WF-TB4-NS6	1.16 (29.5)	0.38 (9.7)	0.59 (15.0)	0.87 (22.2)	0.12 (3.0)	5300 (365)	
3/8	0.095	1/4	-WF-TB6-NS4	1.10 (27.9)	0.38 (9.7)	0.59 (15.0)	0.75 (19.1)	0.19 (4.7)	6600 (454)	
3/8	0.095	3/8	-WF-TB6-NS6	1.16 (29.5)	0.38 (9.7)	0.59 (15.0)	0.87 (22.2)	0.19 (4.7)	5300 (365)	
1/2	0.095	1/4	-WF-TB8-NS4	1.34 (34.0)	0.56 (14.2)	0.59 (15.0)	0.75 (19.1)	0.31 (7.9)	6600 (454)	
1/2	0.095	3/8	-WF-TB8-NS6	1.34 (34.0)	0.56 (14.2)	0.59 (15.0)	0.87 (22.2)	0.31 (7.9)	5300 (365)	
1/2	0.095	1/2	-WF-TB8-NS8	1.53 (38.9)	0.56 (14.2)	0.78 (19.8)	1.06 (27.0)	0.31 (7.9)	4900 (337)	

Metric Tube				Dimensions, mm (in.)					NPT Thread	Working Pressure psig (bar)
T-Tube O.D. (mm)	t-Wall Thickness (mm)	P-NPT Size	Basic Ordering Number	L	B	Bx	F	E		
14	2.5	1/4	-WF-MTB14-NS4	33.0 (1.30)	14.2 (0.56)	15.0 (0.59)	19.0 (0.75)	9.0 (0.35)	6280 (433)	
14	2.5	1/2	-WF-MTB14-NS8	38.9 (1.53)	14.2 (0.56)	19.8 (0.78)	27.0 (1.06)	9.0 (0.35)	4900 (337)	
20	3.0	1/2	-WF-MTB20-NS8	43.7 (1.72)	19.1 (0.75)	19.8 (0.78)	27.0 (1.06)	14.0 (0.55)	4900 (337)	
28	4.0	1/2	-WF-MTB28-NS8	49.8 (1.96)	23.9 (0.94)	19.8 (0.78)	30.0 (1.18)	15.7 (0.62)	4850 (335)	

Reducing Unions

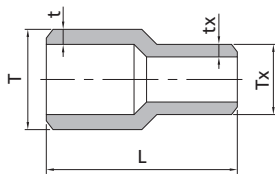

Fractional Tube				Fractional Tube		
T-Tube O.D. (in.)	t-Wall Thickness (in.)	Tx-Tube O.D. (in.)	tx-Wall Thickness (in.)	Basic Ordering Number	L in. (mm)	Working Pressure psig (bar)
3/8	0.095	1/4	0.065	-WU-TB6-TB4	1.50 (38.1)	9930 (685)
1/2	0.095	1/4	0.065	-WU-TB8-TB4	1.50 (38.1)	6780 (468)
1/2	0.095	3/8	0.095	-WU-TB8-TB6	1.50 (38.1)	6780 (468)
3/4	0.120	1/2	0.095	-WU-TB12-TB8	1.50 (38.1)	5530 (381)
1	0.134	3/4	0.120	-WU-TB16-TB12	1.50 (38.1)	4480 (309)

Metric Tube				Metric Tube		
T-Tube O.D. (mm)	t-Wall Thickness (mm)	Tx-Tube O.D. (mm)	tx-Wall Thickness (mm)	Basic Ordering Number	L mm (in.)	Working Pressure psig (bar)
20	3.0	14	2.5	-WU-MTB20-MTB14	38.1 (1.50)	6470 (445)
22	3.0	14	2.5	-WU-MTB22-MTB14	38.1 (1.50)	5780 (395)
22	3.0	18	2.8	-WU-MTB22-MTB18	38.1 (1.50)	5780 (395)
25	3.5	22	3.0	-WU-MTB25-MTB22	38.1 (1.50)	5780 (395)
38	5.0	25	3.5	-WU-MTB38-MTB25	38.1 (1.50)	5540 (380)

Union Elbows

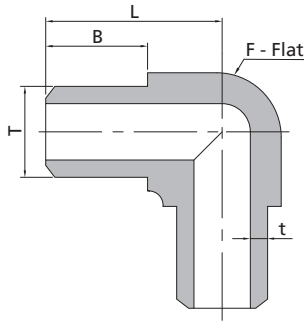

Fractional Tube

T-Tube O.D. (in.)	t-Wall Thickness (in.)	Basic Ordering Number	Dimensions, in. (mm)			Working Pressure psig (bar)
			L	B	F	
1/4	0.065	-WLU-TB4	0.64 (16.3)	0.38 (9.7)	0.37 (9.5)	10320 (712)
3/8	0.095	-WLU-TB6	0.71 (18.0)	0.38 (9.7)	0.44 (11.1)	9930 (685)
1/2	0.095	-WLU-TB8	0.96 (24.4)	0.56 (14.2)	0.56 (14.3)	6780 (468)
3/4	0.120	-WLU-TB12	1.31 (33.3)	0.75 (19.1)	0.81 (20.6)	5530 (381)
1	0.134	-WLU-TB16	1.46 (37.1)	0.75 (19.1)	1.06 (27.0)	4480 (309)

Metric Tube

T-Tube O.D. (mm)	t-Wall Thickness (mm)	Basic Ordering Number	Dimensions, mm (in.)			Working Pressure psig (bar)
			L	B	F	
10	2.2	-WLU-MTB10	18.0 (0.71)	9.7 (0.38)	11.1 (0.44)	8160 (563)
14	2.5	-WLU-MTB14	25.4 (1.00)	14.2 (0.56)	15.9 (0.63)	6280 (433)
16	2.8	-WLU-MTB16	26.2 (1.03)	14.2 (0.56)	17.5 (0.69)	6140 (423)
20	3.0	-WLU-MTB20	33.3 (1.31)	19.1 (0.75)	20.6 (0.81)	5110 (352)
22	3.0	-WLU-MTB22	35.3 (1.39)	19.1 (0.75)	23.8 (0.94)	4620 (319)
25	3.5	-WLU-MTB25	37.1 (1.46)	19.1 (0.75)	27.0 (1.06)	4730 (326)

Union Tees

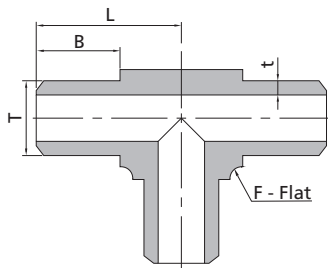

Fractional Tube

T-Tube O.D. (in.)	t-Wall Thickness (in.)	Basic Ordering Number	Dimensions, in. (mm)			Working Pressure psig (bar)
			L	B	F	
1/4	0.065	-WT-TB4	0.64 (16.3)	0.38 (9.7)	0.37 (9.5)	10320 (712)
3/8	0.095	-WT-TB6	0.71 (18.0)	0.38 (9.7)	0.44 (11.1)	9930 (685)
1/2	0.095	-WT-TB8	0.96 (24.4)	0.56 (14.2)	0.56 (14.3)	6780 (468)
3/4	0.120	-WT-TB12	1.31 (33.3)	0.75 (19.1)	0.81 (20.6)	5530 (381)
1	0.134	-WT-TB16	1.46 (37.1)	0.75 (19.1)	1.06 (27.0)	4480 (309)

Metric Tube

T-Tube O.D. (mm)	t-Wall Thickness (mm)	Basic Ordering Number	Dimensions, mm (in.)			Working Pressure psig (bar)
			L	B	F	
6	1.8	-WT-MTB6	16.3 (0.64)	9.7 (0.38)	9.5 (0.37)	12660 (873)
8	1.8	-WT-MTB8	16.3 (0.64)	9.7 (0.38)	9.5 (0.37)	8320 (574)
10	2.2	-WT-MTB10	18.0 (0.71)	9.7 (0.38)	11.1 (0.44)	8160 (563)
12	2.2	-WT-MTB12	24.4 (0.96)	14.2 (0.56)	14.3 (0.56)	6470 (446)
14	2.5	-WT-MTB14	25.4 (1.00)	14.2 (0.56)	15.9 (0.63)	6280 (433)
16	2.8	-WT-MTB16	26.2 (1.03)	14.2 (0.56)	17.5 (0.69)	6140 (423)
20	3.0	-WT-MTB20	33.3 (1.31)	19.1 (0.75)	20.6 (0.81)	5110 (352)
22	3.0	-WT-MTB22	35.3 (1.39)	19.1 (0.75)	23.8 (0.94)	4620 (319)
25	3.5	-WT-MTB25	37.1 (1.46)	19.1 (0.75)	27.0 (1.06)	4730 (326)
32	4.5	-WT-MTB32	49.3 (1.94)	23.9 (0.94)	34.9 (1.37)	4730 (326)

Union Crosses

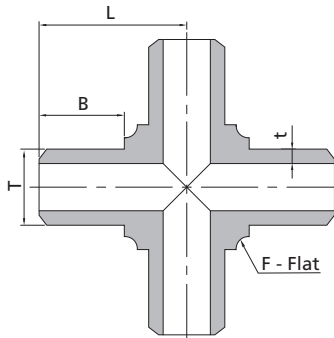

Pipe Fittings
Weld Fittings

Fractional Tube						
T-Tube O.D. (in.)	t-Wall Thickness (in.)	Basic Ordering Number	Dimensions, in. (mm)			Working Pressure psig (bar)
			L	B	F	
1/4	0.065	-WC-TB4	0.64 (16.3)	0.38 (9.7)	0.37 (9.5)	10320 (712)
3/8	0.095	-WC-TB6	0.71 (18.0)	0.38 (9.7)	0.44 (11.1)	9930 (685)
1/2	0.095	-WC-TB8	0.96 (24.4)	0.56 (14.2)	0.56 (14.3)	6780 (468)
3/4	0.120	-WC-TB12	1.31 (33.3)	0.75 (19.1)	0.81 (20.6)	5530 (381)
1	0.134	-WC-TB16	1.46 (37.1)	0.75 (19.1)	1.06 (27.0)	4480 (309)

Metric Tube						
T-Tube O.D. (mm)	t-Wall Thickness (mm)	Basic Ordering Number	Dimensions, mm (in.)			Working Pressure psig (bar)
			L	B	F	
6	1.8	-WC-MTB6	16.3 (0.64)	9.7 (0.38)	9.5 (0.37)	12660 (873)
8	1.8	-WC-MTB8	16.3 (0.64)	9.7 (0.38)	9.5 (0.37)	8320 (574)
10	2.2	-WC-MTB10	18.0 (0.71)	9.7 (0.38)	11.1 (0.44)	8160 (563)

Tube Socket Weld Fittings

Male Connectors

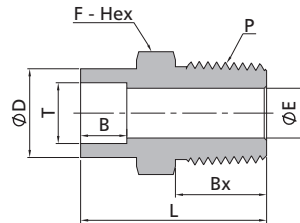

Fractional Tube							NPT Thread		
T-Tube Size (in.)	P-NPT Size	Basic Ordering Number	Dimensions, in. (mm)					Working Pressure psig (bar)	
			L	D	B	Bx	F		E
1/4	1/4	-WM-TS4-NS4	1.15 (29.2)	0.48 (12.2)	0.28 (7.1)	0.56 (14.2)	0.56 (14.3)	0.19 (4.8)	8000 (551)
3/8	1/4	-WM-TS6-NS4	1.25 (31.8)	0.60 (15.2)	0.31 (7.9)	0.56 (14.2)	0.63 (15.9)	0.28 (7.1)	8000 (551)
3/8	3/8	-WM-TS6-NS6	1.25 (31.8)	0.60 (15.2)	0.31 (7.9)	0.56 (14.2)	0.69 (17.5)	0.28 (7.1)	7800 (537)
3/8	1/2	-WM-TS6-NS8	1.47 (37.3)	0.60 (15.2)	0.31 (7.9)	0.75 (19.1)	0.87 (22.2)	0.28 (7.1)	7700 (530)
1/2	1/4	-WM-TS8-NS4	1.31 (33.3)	0.73 (18.5)	0.38 (9.7)	0.56 (14.2)	0.75 (19.1)	0.28 (7.1)	6600 (454)
1/2	3/8	-WM-TS8-NS6	1.31 (33.3)	0.73 (18.5)	0.38 (9.7)	0.56 (14.2)	0.75 (19.1)	0.38 (9.6)	6600 (454)
1/2	1/2	-WM-TS8-NS8	1.53 (38.9)	0.73 (18.5)	0.38 (9.7)	0.75 (19.1)	0.87 (22.2)	0.41 (10.4)	6600 (454)
3/4	3/4	-WM-TS12-NS12	1.78 (45.1)	1.04 (26.4)	0.44 (11.2)	0.75 (19.1)	1.06 (27.0)	0.62 (15.7)	5900 (406)
1	1	-WM-TS16-NS16	2.11 (53.6)	1.36 (34.5)	0.62 (15.7)	0.94 (23.9)	1.37 (34.9)	0.88 (22.4)	5300 (365)

Metric Tube							NPT Thread		
T-Tube Size (mm)	P-NPT Size	Basic Ordering Number	Dimensions, mm (in.)					Working Pressure psig (bar)	
			L	D	B	Bx	F		E
6	1/4	-WM-MTS6-NS4	29.2 (1.15)	12.0 (0.47)	7.1 (0.28)	14.2 (0.56)	14.0 (0.55)	4.8 (0.19)	8000 (551)
12	1/2	-WM-MTS12-NS8	38.9 (1.53)	20.2 (0.80)	9.7 (0.38)	19.1 (0.75)	22.0 (0.87)	9.5 (0.37)	6820 (470)
14	1/4	-WM-MTS14-NS4	33.3 (1.31)	23.8 (0.94)	10.0 (0.39)	14.2 (0.56)	24.0 (0.94)	7.1 (0.28)	6930 (478)
14	3/8	-WM-MTS14-NS6	35.0 (1.38)	23.8 (0.94)	10.0 (0.39)	14.2 (0.56)	24.0 (0.94)	9.6 (0.38)	6930 (478)
14	1/2	-WM-MTS14-NS8	40.0 (1.57)	23.8 (0.94)	10.0 (0.39)	19.1 (0.75)	24.0 (0.94)	10.4 (0.41)	6930 (478)
16	1/4	-WM-MTS16-NS4	35.0 (1.38)	23.8 (0.94)	10.4 (0.41)	14.2 (0.56)	24.0 (0.94)	7.1 (0.28)	6190 (426)
16	1/2	-WM-MTS16-NS8	40.0 (1.57)	23.8 (0.94)	10.4 (0.41)	19.1 (0.75)	24.0 (0.94)	11.9 (0.47)	6190 (426)
18	1/4	-WM-MTS18-NS4	40.1 (1.58)	26.0 (1.02)	11.2 (0.44)	14.2 (0.56)	27.0 (1.06)	7.1 (0.28)	6050 (417)
28	3/4	-WM-MTS28-NS12	55.5 (2.19)	40.0 (1.57)	20.0 (0.79)	19.1 (0.75)	41.0 (1.61)	15.7 (0.62)	5040 (348)
38	1 1/4	-WM-MTS38-NS20	68.3 (2.69)	50.8 (2.00)	22.0 (0.87)	23.9 (0.94)	52.0 (2.05)	28.6 (1.13)	5000 (344)

Female Connectors

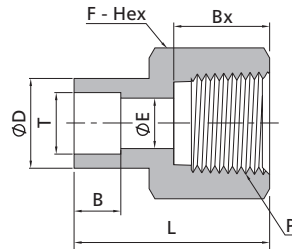

Fractional Tube			Dimensions, in. (mm)							NPT Thread	Working Pressure psig (bar)
T-Tube Size (in.)	P-NPT Size	Basic Ordering Number	L	D	B	Bx	F	E			
1/8	1/8	-WF-TS2-NS2	0.83 (21.1)	0.29 (7.4)	0.10 (2.5)	0.41 (10.4)	0.56 (14.3)	0.09 (2.3)		6500 (447)	
1/4	1/8	-WF-TS4-NS2	1.05 (26.7)	0.48 (12.2)	0.28 (7.1)	0.41 (10.4)	0.56 (14.3)	0.19 (4.8)		6500 (447)	
1/4	1/4	-WF-TS4-NS4	1.18 (30.0)	0.48 (12.2)	0.28 (7.1)	0.59 (15.0)	0.75 (19.1)	0.19 (4.8)		6600 (454)	
3/8	1/4	-WF-TS6-NS4	1.24 (31.5)	0.60 (15.2)	0.31 (7.9)	0.59 (15.0)	0.75 (19.1)	0.28 (7.1)		6600 (454)	
1/2	3/8	-WF-TS8-NS6	1.36 (34.5)	0.73 (18.5)	0.38 (9.7)	0.59 (15.0)	0.87 (22.2)	0.41 (10.4)		5300 (365)	
1/2	1/2	-WF-TS8-NS8	1.59 (40.4)	0.73 (18.5)	0.38 (9.7)	0.78 (19.8)	1.06 (27.0)	0.41 (10.4)		4900 (337)	
3/4	3/4	-WF-TS12-NS12	1.73 (43.9)	1.04 (26.4)	0.44 (11.2)	0.81 (20.6)	1.31 (33.3)	0.63 (16.0)		4600 (316)	
1	1	-WF-TS16-NS16	2.13 (54.1)	1.36 (34.5)	0.62 (15.7)	1.00 (25.4)	1.63 (41.3)	0.88 (22.4)		4400 (303)	

Metric Tube			Dimensions, mm (in.)							NPT Thread	Working Pressure psig (bar)
T-Tube Size (mm)	P-NPT Size	Basic Ordering Number	L	D	B	Bx	F	E			
8	1/4	-WF-MTS8-NS4	27.0 (1.06)	14.3 (0.56)	7.9 (0.31)	15.0 (0.59)	19.0 (0.75)	4.8 (0.19)		6600 (454)	
10	1/4	-WF-MTS10-NS4	29.0 (1.14)	16.5 (0.65)	7.9 (0.31)	15.0 (0.59)	19.0 (0.75)	7.1 (0.28)		6600 (454)	
14	1/4	-WF-MTS14-NS4	32.0 (1.26)	23.8 (0.94)	10.0 (0.39)	15.0 (0.59)	24.0 (0.94)	9.5 (0.37)		6930 (478)	
28	3/4	-WF-MTS28-NS12	54.1 (2.13)	40.0 (1.57)	20.0 (0.79)	20.6 (0.81)	41.0 (1.61)	19.8 (0.78)		4600 (316)	

Male Elbows

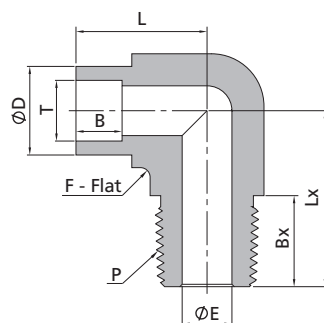

Fractional Tube			Dimensions, in. (mm)							NPT Thread	Working Pressure psig (bar)
T-Tube Size (in.)	P-NPT Size	Basic Ordering Number	L	Lx	D	B	Bx	F	E		
1/4	1/4	SS-WLM-TS4-NS4	0.79 (20.1)	1.05 (26.7)	0.58 (14.7)	0.28 (7.1)	0.56 (14.2)	0.50 (12.7)	0.19 (4.8)	8000 (551)	
3/8	1/4	SS-WLM-TS6-NS4	1.04 (26.4)	1.05 (26.7)	0.58 (14.7)	0.31 (7.9)	0.56 (14.2)	0.50 (12.7)	0.28 (7.1)	8000 (551)	
3/8	3/8	SS-WLM-TS6-NS6	0.97 (24.6)	1.17 (29.7)	0.80 (20.2)	0.31 (7.9)	0.56 (14.2)	0.69 (17.5)	0.28 (7.1)	7800 (537)	
3/8	1/2	SS-WLM-TS6-NS8	1.02 (25.9)	1.45 (36.8)	0.94 (23.8)	0.31 (7.9)	0.75 (19.1)	0.81 (20.6)	0.28 (7.1)	7700 (530)	
1/2	1/2	SS-WLM-TS8-NS8	1.08 (27.4)	1.45 (36.8)	0.94 (23.8)	0.38 (9.7)	0.75 (19.1)	0.81 (20.6)	0.41 (10.4)	6600 (454)	
3/4	3/4	SS-WLM-TS12-NS12	1.53 (38.9)	1.56 (39.6)	1.04 (26.4)	0.44 (11.2)	0.75 (19.1)	1.06 (27.0)	0.62 (15.7)	5900 (406)	

Female Elbows

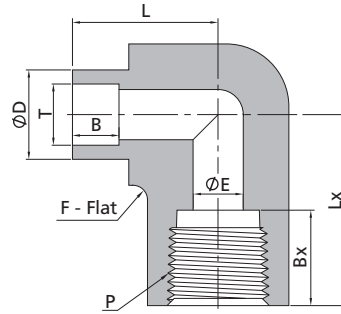

Pipe Fittings
Weld Fittings

Fractional Tube			Dimensions, in. (mm)							NPT Thread	Working Pressure psig (bar)
T-Tube Size (in.)	P-NPT Size	Basic Ordering Number	L	Lx	D	B	Bx	F	E		
1/4	1/4	SS-WLF-TS4-NS4	0.90 (22.9)	1.17 (29.7)	0.80 (20.2)	0.28 (7.1)	0.59 (15.0)	0.69 (17.5)	0.19 (4.8)		7400 (509)
3/8	1/4	SS-WLF-TS6-NS4	0.99 (25.1)	1.17 (29.7)	0.80 (20.2)	0.31 (7.9)	0.59 (15.0)	0.69 (17.5)	0.28 (7.1)		7400 (509)
3/8	1/2	SS-WLF-TS6-NS8	1.13 (28.7)	1.56 (39.6)	1.15 (29.3)	0.31 (7.9)	0.78 (19.8)	1.00 (25.4)	0.28 (7.1)		5700 (392)
1/2	1/2	SS-WLF-TS8-NS8	1.19 (30.2)	1.56 (39.6)	1.15 (29.3)	0.38 (9.7)	0.78 (19.8)	1.00 (25.4)	0.41 (10.4)		5700 (392)

Unions

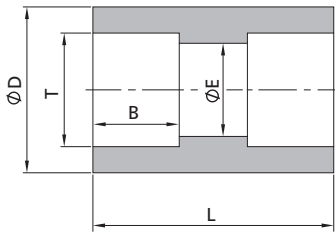

Fractional Tube		Dimensions, in. (mm)				Working Pressure psig (bar)
T-Tube Size (in.)	Basic Ordering Number	L	D	B	E	
1/4	SS-WU-TS4	0.75 (19.1)	0.48 (12.2)	0.28 (7.1)	0.19 (4.8)	10700 (737)
3/8	SS-WU-TS6	0.88 (22.4)	0.60 (15.2)	0.31 (7.9)	0.28 (7.1)	8100 (558)
1/2	SS-WU-TS8	1.06 (26.9)	0.73 (18.5)	0.38 (9.7)	0.41 (10.4)	6600 (454)
5/8	SS-WU-TS10	1.19 (30.2)	0.92 (23.4)	0.41 (10.4)	0.50 (12.7)	6200 (427)
3/4	SS-WU-TS12	1.31 (33.3)	1.04 (26.4)	0.44 (11.2)	0.63 (16.0)	5900 (406)
7/8	SS-WU-TS14	1.40 (35.5)	1.24 (31.5)	0.50 (12.7)	0.74 (18.8)	5730 (395)
1	SS-WU-TS16	1.44 (36.6)	1.36 (34.5)	0.62 (15.7)	0.88 (22.4)	5600 (385)

Metric Tube		Dimensions, mm (in.)				Working Pressure psig (bar)
T-Tube Size (mm)	Basic Ordering Number	L	D	B	E	
8	SS-WU-MTS8	22.4 (0.88)	14.3 (0.56)	7.9 (0.31)	6.4 (0.25)	9790 (675)
10	SS-WU-MTS10	23.6 (0.93)	16.5 (0.65)	7.9 (0.31)	7.4 (0.29)	8100 (558)
12	SS-WU-MTS12	26.9 (1.06)	20.2 (0.80)	9.7 (0.38)	9.5 (0.37)	6820 (470)
14	SS-WU-MTS14	28.0 (1.10)	23.8 (0.94)	10.0 (0.39)	10.4 (0.41)	6930 (478)
16	SS-WU-MTS16	30.2 (1.19)	23.8 (0.94)	10.4 (0.41)	12.7 (0.50)	6190 (426)
20	SS-WU-MTS20	28.0 (1.10)	27.0 (1.06)	11.2 (0.44)	17.0 (0.67)	5510 (380)

Reducing Unions

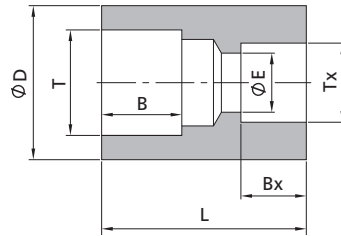

Fractional Tube			Dimensions, in. (mm)					Working Pressure psig (bar)
T-Tube Size (in.)	Tx-Tube Size (in.)	Basic Ordering Number	L	D	B	E	Bx	Working Pressure psig (bar)
3/8	1/4	-WU-TS6-TS4	0.88 (22.4)	0.60 (15.2)	0.31 (7.9)	0.19 (4.8)	0.28 (7.1)	
1/2	1/4	-WU-TS8-TS4	0.96 (24.3)	0.73 (18.5)	0.38 (9.7)	0.19 (4.8)	0.28 (7.1)	6600 (454)
1/2	3/8	-WU-TS8-TS6	1.03 (26.1)	0.73 (18.5)	0.38 (9.7)	0.28 (7.1)	0.31 (7.9)	6600 (454)
3/4	3/8	-WU-TS12-TS6	1.17 (29.8)	1.04 (26.4)	0.44 (11.2)	0.28 (7.1)	0.31 (7.9)	5900 (406)
3/4	1/2	-WU-TS12-TS8	1.24 (31.6)	1.04 (26.4)	0.44 (11.2)	0.41 (10.4)	0.38 (9.7)	5900 (406)
1	3/4	-WU-TS16-TS12	1.26 (32.1)	1.36 (34.5)	0.62 (15.7)	0.63 (16.0)	0.44 (11.2)	5600 (385)

Metric Tube			Dimensions, mm (in.)					Working Pressure psig (bar)
T-Tube Size (mm)	Tx-Tube Size (mm)	Basic Ordering Number	L	D	B	E	Bx	Working Pressure psig (bar)
14	10	-WU-MTS14-MTS10	26.0 (1.02)	23.8 (0.94)	10.4 (0.41)	7.4 (0.29)	7.9 (0.31)	
25	14	-WU-MTS25-MTS14	30.0 (1.18)	34.5 (1.36)	15.7 (0.62)	10.4 (0.41)	10.0 (0.39)	5450 (376)
25	22	-WU-MTS25-MTS22	35.8 (1.41)	34.5 (1.36)	15.7 (0.62)	19.0 (0.75)	13.5 (0.53)	5450 (376)

Metric Tube			Dimensions, mm (in.)					Working Pressure psig (bar)
T-Tube Size (mm)	Tx-Tube Size (in.)	Basic Ordering Number	L	D	B	E	Bx	Working Pressure psig (bar)
20	3/4	-WU-MTS20-TS12	28.0 (1.10)	27.0 (1.06)	11.2 (0.44)	15.7 (0.62)	11.2 (0.44)	
28	3/4	-WU-MTS28-TS12	36.8 (1.45)	40.0 (1.57)	20.0 (0.79)	15.7 (0.62)	11.2 (0.44)	5040 (348)

Union Elbows

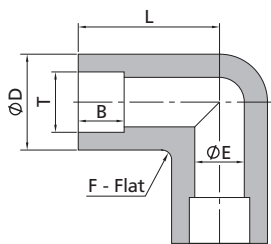

Fractional Tube		Dimensions, in. (mm)					Working Pressure psig (bar)
T-Tube Size (in.)	Basic Ordering Number	L	D	B	F	E	Working Pressure psig (bar)
1/8	-WLU-TS2	0.59 (15.0)	0.43 (11.0)	0.10 (2.5)	0.37 (9.5)	0.09 (2.3)	
1/4	-WLU-TS4	0.86 (21.8)	0.50 (12.8)	0.28 (7.1)	0.44 (11.1)	0.19 (4.8)	10700 (737)
3/8	-WLU-TS6	1.04 (26.4)	0.65 (16.5)	0.31 (7.9)	0.56 (14.3)	0.28 (7.1)	8100 (558)
1/2	-WLU-TS8	1.17 (29.7)	0.80 (20.2)	0.38 (9.7)	0.69 (17.5)	0.41 (10.4)	6600 (454)
5/8	-WLU-TS10	1.42 (36.1)	0.94 (23.8)	0.41 (10.4)	0.81 (20.6)	0.50 (12.7)	6200 (427)
3/4	-WLU-TS12	1.56 (39.6)	1.15 (29.3)	0.44 (11.2)	1.00 (25.4)	0.63 (16.0)	5900 (406)
1	-WLU-TS16	1.92 (48.8)	1.44 (36.7)	0.62 (15.7)	1.25 (31.8)	0.88 (22.4)	5600 (385)

Metric Tube		Dimensions, mm (in.)					Working Pressure psig (bar)
T-Tube Size (mm)	Basic Ordering Number	L	D	B	F	E	Working Pressure psig (bar)
10	-WLU-MTS10	24.6 (0.97)	16.5 (0.65)	7.9 (0.31)	14.3 (0.56)	7.4 (0.29)	
12	-WLU-MTS12	29.7 (1.17)	20.2 (0.80)	9.7 (0.38)	17.5 (0.69)	9.5 (0.37)	6820 (470)
14	-WLU-MTS14	31.7 (1.25)	23.8 (0.94)	10.0 (0.39)	20.6 (0.81)	10.4 (0.41)	6930 (478)
16	-WLU-MTS16	34.7 (1.37)	23.8 (0.94)	10.4 (0.41)	20.6 (0.81)	12.7 (0.50)	6190 (426)

Union 45° Elbows

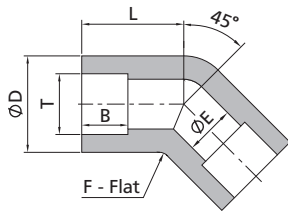

Fractional Tube		Dimensions, in. (mm)					Working Pressure psig (bar)
T-Tube Size (in.)	Basic Ordering Number	L	D	B	F	E	
1/4	SS-WV-TS4	0.59 (15.0)	0.58 (14.7)	0.28 (7.1)	0.50 (12.7)	0.19 (4.8)	10700 (737)
3/8	SS-WV-TS6	0.78 (19.7)	0.65 (16.5)	0.31 (7.9)	0.56 (14.3)	0.28 (7.1)	8100 (558)
1/2	SS-WV-TS8	0.84 (21.3)	0.80 (20.2)	0.38 (9.7)	0.69 (17.5)	0.41 (10.4)	6600 (454)
3/4	SS-WV-TS12	1.13 (28.7)	1.15 (29.3)	0.44 (11.2)	1.00 (25.4)	0.63 (16.0)	5900 (406)
1	SS-WV-TS16	1.57 (40.0)	1.59 (40.3)	0.62 (15.7)	1.37 (34.9)	0.88 (22.4)	5600 (385)

Metric Tube		Dimensions, mm (in.)					Working Pressure psig (bar)
T-Tube Size (mm)	Basic Ordering Number	L	D	B	F	E	
8	SS-WV-MTS8	17.3 (0.68)	14.7 (0.58)	7.9 (0.31)	12.7 (0.50)	6.4 (0.25)	9790 (675)
10	SS-WV-MTS10	19.1 (0.75)	16.5 (0.65)	7.9 (0.31)	14.3 (0.56)	7.4 (0.29)	8100 (558)
12	SS-WV-MTS12	21.3 (0.84)	20.2 (0.80)	9.7 (0.38)	17.5 (0.69)	9.5 (0.37)	6820 (470)
14	SS-WV-MTS14	26.4 (1.04)	23.8 (0.94)	10.0 (0.39)	20.6 (0.81)	10.4 (0.41)	6930 (478)
16	SS-WV-MTS16	26.4 (1.04)	23.8 (0.94)	10.4 (0.41)	20.6 (0.81)	12.7 (0.50)	6190 (426)
20	SS-WV-MTS20	28.7 (1.13)	29.3 (1.15)	11.2 (0.44)	25.4 (1.00)	17.0 (0.67)	5510 (380)
22	SS-WV-MTS22	29.7 (1.17)	31.2 (1.23)	13.5 (0.53)	27.0 (1.06)	19.0 (0.75)	5700 (396)
23	SS-WV-MTS25	40.0 (1.57)	40.3 (1.59)	15.7 (0.62)	34.9 (1.37)	22.0 (0.87)	5450 (376)

Union Tees

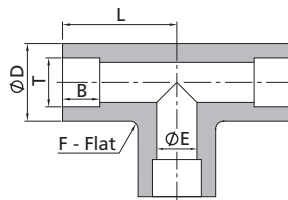

Fractional Tube		Dimensions, in. (mm)					Working Pressure psig (bar)
T-Tube Size (in.)	Basic Ordering Number	L	D	B	F	E	
1/8	-WT-TS2	0.59 (15.0)	0.39 (10.0)	0.10 (2.5)	0.44 (11.1)	0.09 (2.3)	12600 (868)
1/4	-WT-TS4	0.86 (21.8)	0.50 (12.8)	0.28 (7.1)	0.44 (11.1)	0.19 (4.8)	10700 (737)
3/8	-WT-TS6	1.04 (26.4)	0.65 (16.5)	0.31 (7.9)	0.56 (14.3)	0.28 (7.1)	8100 (558)
1/2	-WT-TS8	1.17 (29.7)	0.80 (20.2)	0.38 (9.7)	0.69 (17.5)	0.41 (10.4)	6600 (454)
5/8	-WT-TS10	1.42 (36.1)	0.94 (23.8)	0.41 (10.4)	0.81 (20.6)	0.50 (12.7)	6200 (428)
3/4	-WT-TS12	1.56 (39.6)	1.15 (29.3)	0.44 (11.2)	1.00 (25.4)	0.63 (16.0)	5900 (406)
1	-WT-TS16	1.92 (48.8)	1.44 (36.7)	0.62 (15.7)	1.25 (31.8)	0.88 (22.4)	5600 (385)

Metric Tube		Dimensions, mm (in.)					Working Pressure psig (bar)
T-Tube Size (mm)	Basic Ordering Number	L	D	B	F	E	
8	-WT-MTS8	19.8 (0.78)	14.7 (0.58)	7.9 (0.31)	12.7 (0.50)	6.4 (0.25)	9790 (675)
10	-WT-MTS10	24.6 (0.97)	16.5 (0.65)	7.9 (0.31)	14.3 (0.56)	7.4 (0.29)	8100 (558)
12	-WT-MTS12	29.7 (1.17)	20.2 (0.80)	9.7 (0.38)	17.5 (0.69)	9.5 (0.37)	6820 (470)
14	-WT-MTS14	31.7 (1.25)	23.8 (0.94)	10.0 (0.39)	20.6 (0.81)	10.4 (0.41)	6930 (478)
16	-WT-MTS16	36.0 (1.42)	23.8 (0.94)	10.4 (0.41)	20.6 (0.81)	12.7 (0.50)	6190 (426)
20	-WT-MTS20	39.6 (1.56)	29.3 (1.15)	11.2 (0.44)	25.4 (1.00)	17.0 (0.67)	5510 (380)
22	-WT-MTS22	41.3 (1.63)	31.2 (1.23)	13.5 (0.53)	27.0 (1.06)	19.0 (0.75)	5700 (396)
25	-WT-MTS25	48.8 (1.92)	36.7 (1.44)	15.7 (0.62)	31.8 (1.25)	22.0 (0.87)	5450 (376)

Union Crosses

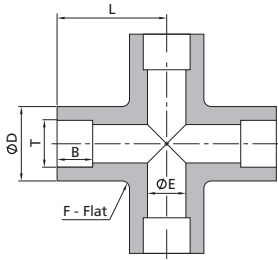

Fractional Tube		Dimensions, in. (mm)					Working Pressure psig (bar)
T-Tube Size (in.)	Basic Ordering Number	L	D	B	F	E	
1/8	-WC-TS2	0.59 (15.0)	0.43 (11.0)	0.10 (2.5)	0.44 (11.1)	0.09 (2.3)	12600 (863)
1/4	-WC-TS4	0.86 (21.8)	0.50 (12.8)	0.28 (7.1)	0.44 (11.1)	0.19 (4.8)	10700 (737)
3/8	-WC-TS6	1.04 (26.4)	0.58 (14.7)	0.31 (7.9)	0.50 (12.7)	0.28 (7.1)	8100 (558)
1/2	-WC-TS8	1.17 (29.7)	0.80 (20.2)	0.38 (9.7)	0.69 (17.5)	0.41 (10.4)	6600 (454)
5/8	-WC-TS10	1.42 (36.1)	0.94 (23.8)	0.41 (10.4)	0.81 (20.6)	0.50 (12.7)	6200 (428)
3/4	-WC-TS12	1.56 (39.6)	1.15 (29.3)	0.44 (11.2)	1.00 (25.4)	0.63 (16.0)	5900 (406)
1	-WC-TS16	1.92 (48.8)	1.44 (36.7)	0.62 (15.7)	1.25 (31.8)	0.88 (22.4)	5600 (385)

Metric Tube		Dimensions, mm (in.)					Working Pressure psig (bar)
T-Tube Size (mm)	Basic Ordering Number	L	D	B	F	E	
8	-WC-MTS8	19.8 (0.78)	14.7 (0.58)	7.9 (0.31)	12.7 (0.50)	6.4 (0.25)	9790 (675)
10	-WC-MTS10	24.6 (0.97)	16.5 (0.65)	7.9 (0.31)	14.3 (0.56)	7.1 (0.28)	8100 (558)
12	-WC-MTS12	29.7 (1.17)	20.2 (0.80)	9.7 (0.38)	17.5 (0.69)	9.5 (0.37)	6820 (470)
14	-WC-MTS14	31.7 (1.25)	23.8 (0.94)	10.0 (0.39)	20.6 (0.81)	10.4 (0.41)	6930 (478)
16	-WC-MTS16	36.0 (1.42)	23.8 (0.94)	10.4 (0.41)	20.6 (0.81)	12.7 (0.50)	6190 (426)
20	-WC-MTS20	39.6 (1.56)	29.3 (1.15)	11.2 (0.44)	25.4 (1.00)	17.0 (0.67)	5510 (380)
22	-WC-MTS22	1.22 (31.00)	31.2 (1.23)	13.5 (0.53)	27.0 (1.06)	19.0 (0.75)	5700 (396)
25	-WC-MTS25	48.8 (1.92)	36.7 (1.44)	15.7 (0.62)	31.8 (1.25)	22.0 (0.87)	5450 (376)

Pipe Butt Weld Fittings

Male Connectors

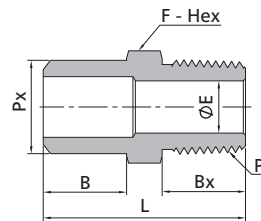

Pipe			Dimensions, in. (mm)					Working Pressure psig (bar)
Px-Sch80 Pipe Size	P-NPT Size	Basic Ordering Number	L	B	Bx	F	E	
1/4	1/4	-WM-PB4-NS4	1.35 (34.3)	0.56 (14.2)	0.56 (14.2)	0.56 (14.3)	0.28 (7.1)	8000 (551)
1/4	1/2	-WM-PB4-NS8	1.63 (41.3)	0.56 (14.2)	0.75 (19.1)	0.87 (22.2)	0.30 (7.7)	7700 (537)
3/8	1/4	-WM-PB6-NS4	1.37 (34.8)	0.56 (14.2)	0.56 (14.2)	0.69 (17.5)	0.28 (7.1)	6650 (459)
3/8	1/2	-WM-PB6-NS8	1.63 (41.3)	0.56 (14.2)	0.75 (19.1)	0.87 (22.2)	0.42 (10.7)	6650 (459)
1/2	1/4	-WM-PB8-NS4	1.63 (41.3)	0.75 (19.1)	0.56 (14.2)	0.87 (22.2)	0.28 (7.1)	6190 (427)
1/2	1/2	-WM-PB8-NS8	1.82 (46.2)	0.75 (19.1)	0.75 (19.1)	0.87 (22.2)	0.47 (11.9)	6190 (427)
3/4	1/4	-WM-PB12-NS4	1.69 (42.9)	0.75 (19.1)	0.56 (14.2)	1.06 (27.0)	0.28 (7.1)	5040 (348)
3/4	1/2	-WM-PB12-NS8	1.88 (47.8)	0.75 (19.1)	0.75 (19.1)	1.06 (27.0)	0.47 (11.9)	5040 (348)
1	1/4	-WM-PB16-NS4	1.97 (50.0)	0.94 (23.9)	0.56 (14.2)	1.37 (34.9)	0.28 (7.1)	4640 (320)
1	1/2	-WM-PB16-NS8	2.16 (54.9)	0.94 (23.9)	0.75 (19.1)	1.37 (34.9)	0.47 (11.9)	4640 (320)

Female Connectors

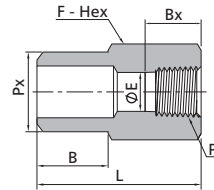

Pipe			Dimensions, in. (mm)					NPT Thread	Working Pressure psig (bar)
Px-Sch80 Pipe Size	P-NPT Size	Basic Ordering Number	L	B	Bx	F	E		
1/4	1/2	-WF-PB4-NS8	1.53 (38.9)	0.56 (14.2)	0.78 (19.8)	1.06 (27.0)	0.30 (7.6)	4900 (337)	
3/8	1/2	-WF-PB6-NS8	1.53 (38.9)	0.56 (14.2)	0.78 (19.8)	1.06 (27.0)	0.42 (10.7)	4900 (337)	
1/2	1/4	-WF-PB8-NS4	1.47 (37.3)	0.75 (19.1)	0.59 (15.0)	0.87 (22.2)	0.41 (10.4)	7500 (516)	
1/2	1/2	-WF-PB8-NS8	1.72 (43.7)	0.75 (19.1)	0.78 (19.8)	1.06 (27.0)	0.55 (13.9)	4900 (337)	

Pipe Socket Weld Fittings

Male Connectors

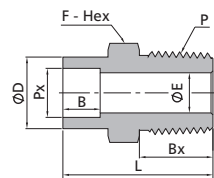

Pipe			Dimensions, in. (mm)					NPT Thread	Working Pressure psig (bar)
Px-Pipe Size	P-NPT Size	Basic Ordering Number	L	D	B	Bx	F	E	
1/4	1/4	-WM-PS4-NS4	1.39 (35.2)	0.88 (22.4)	0.39 (9.9)	0.56 (14.2)	0.94 (23.8)	0.28 (7.1)	8000 (551)
1/4	1/2	-WM-PS4-NS8	1.57 (40.0)	0.88 (22.4)	0.39 (9.9)	0.75 (19.1)	0.94 (23.8)	0.36 (9.1)	7700 (530)
3/8	3/8	-WM-PS6-NS6	1.50 (38.0)	1.03 (26.2)	0.39 (9.9)	0.56 (14.2)	1.06 (27.0)	0.38 (9.7)	7100 (489)
3/8	1/2	-WM-PS6-NS8	1.69 (42.9)	1.03 (26.2)	0.39 (9.9)	0.75 (19.1)	1.06 (27.0)	0.47 (11.9)	7100 (489)
1/2	3/8	-WM-PS8-NS6	1.59 (40.3)	1.25 (31.8)	0.39 (9.9)	0.56 (14.2)	1.31 (33.3)	0.38 (9.7)	6800 (468)
1/2	1/2	-WM-PS8-NS8	1.78 (45.2)	1.25 (31.8)	0.39 (9.9)	0.75 (19.1)	1.31 (33.3)	0.47 (11.9)	6800 (468)
3/4	1/2	-WM-PS12-NS8	2.14 (54.3)	1.47 (37.3)	0.51 (13.0)	0.75 (19.1)	1.50 (38.1)	0.47 (11.9)	5800 (399)
3/4	3/4	-WM-PS12-NS12	2.14 (54.3)	1.47 (37.3)	0.51 (13.0)	0.75 (19.1)	1.50 (38.1)	0.62 (15.7)	5800 (399)
1	3/4	-WM-PS16-NS12	2.20 (55.8)	1.86 (47.2)	0.51 (13.0)	0.75 (19.1)	1.87 (47.6)	0.62 (15.7)	6100 (420)
1	1	-WM-PS16-NS16	2.39 (60.6)	1.86 (47.2)	0.51 (13.0)	0.94 (23.9)	1.87 (47.6)	0.88 (22.4)	5300 (365)

Female Connectors

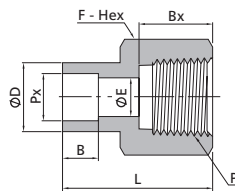

Pipe			Dimensions, in. (mm)					NPT Thread	Working Pressure psig (bar)
Px-Pipe Size	P-NPT Size	Basic Ordering Number	L	D	B	Bx	F	E	
1/4	1/4	-WF-PS4-NS4	1.32 (33.5)	0.88 (22.4)	0.39 (9.9)	0.59 (15.0)	0.94 (23.8)	0.36 (9.1)	8000 (551)
1/4	3/8	-WF-PS4-NS6	1.32 (33.5)	0.88 (22.4)	0.39 (9.9)	0.59 (15.0)	0.94 (23.8)	0.36 (9.1)	6790 (463)
3/8	3/8	-WF-PS6-NS6	1.34 (34.1)	1.03 (26.2)	0.39 (9.9)	0.59 (15.0)	1.06 (27.0)	0.49 (12.4)	7100 (489)
3/8	1/2	-WF-PS6-NS8	1.54 (39.1)	1.03 (26.2)	0.39 (9.9)	0.78 (19.8)	1.06 (27.0)	0.49 (12.4)	4900 (337)
1/2	1/2	-WF-PS8-NS8	1.57 (40.0)	1.25 (31.8)	0.39 (9.9)	0.78 (19.8)	1.31 (33.3)	0.62 (15.7)	6800 (468)
1/2	3/4	-WF-PS8-NS12	1.60 (40.6)	1.25 (31.8)	0.39 (9.9)	0.81 (20.6)	1.31 (33.3)	0.62 (15.7)	4600 (316)
3/4	3/4	-WF-PS12-NS12	2.09 (53.2)	1.47 (37.3)	0.51 (13.0)	0.81 (20.6)	1.50 (38.1)	0.82 (20.8)	5800 (399)
3/4	1	-WF-PS12-NS16	2.29 (58.1)	1.47 (37.3)	0.51 (13.0)	1.00 (25.4)	1.63 (41.3)	0.82 (20.8)	4400 (303)

Unions

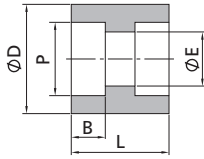

Pipe		Dimensions, in. (mm)				Working Pressure psig (bar)
P-Pipe Size	Basic Ordering Number	L	D	B	E	
1/8	-WU-PS2	1.01 (25.7)	0.67 (17.1)	0.39 (9.9)	0.28 (7.0)	8230 (568)
1/4	-WU-PS4	1.06 (26.9)	0.88 (22.4)	0.39 (9.9)	0.38 (9.7)	8000 (551)
3/8	-WU-PS6	1.12 (28.4)	1.03 (26.2)	0.39 (9.9)	0.49 (12.4)	7100 (489)
1/2	-WU-PS8	1.16 (29.5)	1.25 (31.8)	0.39 (9.9)	0.62 (15.7)	6800 (468)
3/4	-WU-PS12	1.75 (44.5)	1.47 (37.3)	0.51 (13.0)	0.82 (20.8)	5800 (399)
1	-WU-PS16	1.75 (44.5)	1.86 (47.2)	0.51 (13.0)	1.05 (26.7)	6100 (420)

Weld Adapters

Tube Butt Weld to Tube Socket Weld

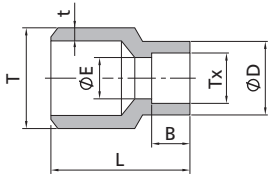

Fractional Tube								
T-Tube O.D. (in.)	t-Wall Thickness (in.)	Tx-Tube Size (in.)	Basic Ordering Number	Dimensions, in. (mm)				Working Pressure psig (bar)
				L	B	D	E	
1/4	0.083	1/8	-WA-TB4-TS2	0.56 (14.2)	0.10 (2.5)	0.31 (8.0)	0.09 (2.3)	12600 (868)
3/8	0.095	1/4	-WA-TB6-TS4	0.75 (19.1)	0.28 (7.1)	0.48 (12.2)	0.19 (4.8)	8200 (564)
1/2	0.095	1/4	-WA-TB8-TS4	0.88 (22.4)	0.28 (7.1)	0.50 (12.7)	0.19 (4.8)	7500 (516)
1/2	0.095	3/8	-WA-TB8-TS6	0.88 (22.4)	0.31 (7.9)	0.60 (15.2)	0.28 (7.1)	7500 (516)
3/4	0.120	1/2	-WA-TB12-TS8	1.12 (28.4)	0.38 (9.7)	0.73 (18.5)	0.41 (10.4)	6300 (434)
1	0.134	1/2	-WA-TB16-TS8	1.38 (35.1)	0.38 (9.7)	0.73 (18.5)	0.41 (10.4)	5300 (365)
1	0.134	3/4	-WA-TB16-TS12	1.50 (38.1)	0.44 (11.2)	1.04 (26.4)	0.63 (16.0)	5300 (365)

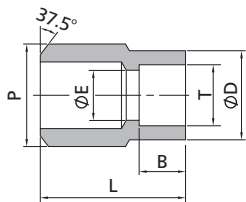
Pipe Butt Weld to
Tube Socket Weld

Pipe			Fractional Tube				Working Pressure psig (bar)
P-Sch80 Pipe Size	T-Tube Size (in.)	Basic Ordering Number	Dimensions, in. (mm)				
			L	B	D	E	
1/4	1/4	-WA-PB4-TS4	0.88 (22.4)	0.28 (7.1)	0.48 (12.2)	0.19 (4.8)	10810 (744)
3/8	1/4	-WA-PB6-TS4	1.03 (26.2)	0.31 (7.9)	0.48 (12.2)	0.19 (4.8)	8500 (586)
3/8	3/8	-WA-PB6-TS6	1.03 (26.2)	0.31 (7.9)	0.60 (15.2)	0.28 (7.1)	8500 (586)
3/8	1/2	-WA-PB6-TS8	1.00 (25.4)	0.38 (9.7)	0.73 (18.5)	0.41 (10.4)	6930 (476)
1/2	1/4	-WA-PB8-TS4	1.12 (28.4)	0.28 (7.1)	0.48 (12.2)	0.19 (4.8)	8190 (563)
1/2	3/8	-WA-PB8-TS6	1.12 (28.4)	0.31 (7.9)	0.60 (15.2)	0.28 (7.1)	8190 (563)
1/2	1/2	-WA-PB8-TS8	1.19 (30.2)	0.38 (9.7)	0.73 (18.5)	0.41 (10.4)	6930 (476)
3/4	1/4	-WA-PB12-TS4	1.50 (38.1)	0.28 (7.1)	0.48 (12.2)	0.19 (4.8)	6930 (476)
3/4	3/8	-WA-PB12-TS6	1.50 (38.1)	0.31 (7.9)	0.60 (15.2)	0.28 (7.1)	6930 (476)
3/4	1/2	-WA-PB12-TS8	1.50 (38.1)	0.38 (9.7)	0.73 (18.5)	0.41 (10.4)	6930 (476)
3/4	3/4	-WA-PB12-TS12	1.50 (38.1)	0.44 (11.2)	1.04 (26.4)	0.63 (16.0)	6190 (483)
1	3/8	-WA-PB16-TS6	1.38 (35.1)	0.31 (7.9)	0.60 (15.2)	0.28 (7.1)	6300 (434)
1	1/2	-WA-PB16-TS8	1.56 (39.6)	0.38 (9.7)	0.73 (18.5)	0.41 (10.4)	6300 (434)

Pipe to Weld Fittings

Pipe to Tube Butt Weld

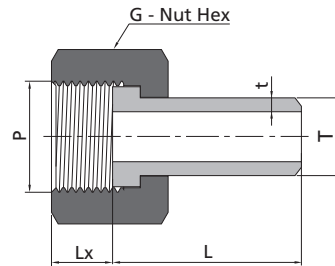

ISO Parallel Thread				Metric Tube			
P-ISO Thread Size	T-Tube O.D. (mm)	t-Wall Thickness (mm)	Basic Ordering Number	Dimensions, mm (in.)			Working Pressure psig (bar)
				L	G	Lx	
1/2	12	2.2	-PUW-RG8-MTB12	34.0 (1.34)	27.0 (1.06)	11.0 (0.43)	6470 (446)
1/2	14	2.5	-PUW-RG8-MTB14	34.0 (1.34)	27.0 (1.06)	11.0 (0.43)	6280 (433)
1/2	16	2.8	-PUW-RG8-MTB16	34.0 (1.34)	27.0 (1.06)	11.0 (0.43)	6140 (423)

Metric Thread				Metric Tube			
P-Metric Thread Size	T-Tube O.D. (mm)	t-Wall Thickness (mm)	Basic Ordering Number	Dimensions, mm (in.)			Working Pressure psig (bar)
				L	G	Lx	
M12 x 1.5	6	1.8	-PUW-MS12-MTB6	25.0 (0.98)	16.0 (0.63)	9.0 (0.35)	12660 (873)
M12 x 1.5	8	1.8	-PUW-MS12-MTB8	30.0 (1.18)	16.0 (0.63)	9.0 (0.35)	8320 (574)
M14 x 1.5	8	1.8	-PUW-MS14-MTB8	30.0 (1.18)	18.0 (0.71)	9.0 (0.35)	8320 (574)
M14 x 1.5	10	2.2	-PUW-MS14-MTB10	30.0 (1.18)	18.0 (0.71)	9.0 (0.35)	8160 (563)
M16 x 1.5	8	1.8	-PUW-MS16-MTB8	30.0 (1.18)	22.0 (0.87)	9.0 (0.35)	8320 (574)
M16 x 1.5	10	2.2	-PUW-MS16-MTB10	30.0 (1.18)	22.0 (0.87)	9.0 (0.35)	8160 (563)
M16 x 1.5	12	2.2	-PUW-MS16-MTB12	34.0 (1.34)	22.0 (0.87)	9.0 (0.35)	6470 (446)
M18 x 1.5	10	2.2	-PUW-MS18-MTB10	34.0 (1.34)	22.0 (0.87)	10.0 (0.39)	8160 (563)
M18 x 1.5	12	2.2	-PUW-MS18-MTB12	34.0 (1.34)	22.0 (0.87)	10.0 (0.39)	6470 (446)
M18 x 1.5	14	2.5	-PUW-MS18-MTB14	34.0 (1.34)	22.0 (0.87)	10.0 (0.39)	6280 (433)
M20 x 1.5	10	2.2	-PUW-MS20-MTB10	34.0 (1.34)	25.0 (0.98)	11.0 (0.43)	8160 (563)
M20 x 1.5	12	2.2	-PUW-MS20-MTB12	34.0 (1.34)	25.0 (0.98)	11.0 (0.43)	6470 (446)
M20 x 1.5	14	2.5	-PUW-MS20-MTB14	34.0 (1.34)	25.0 (0.98)	11.0 (0.43)	6280 (433)
M20 x 1.5	15	2.5	-PUW-MS20-MTB15	34.0 (1.34)	25.0 (0.98)	11.0 (0.43)	6160 (425)
M20 x 1.5	16	2.8	-PUW-MS20-MTB16	34.0 (1.34)	25.0 (0.98)	11.0 (0.43)	6140 (423)
M22 x 1.5	14	2.5	-PUW-MS22-MTB14	34.0 (1.34)	27.0 (1.06)	11.0 (0.43)	6280 (433)
M22 x 1.5	16	2.8	-PUW-MS22-MTB16	34.0 (1.34)	27.0 (1.06)	11.0 (0.43)	6140 (423)
M24 x 1.5	16	2.8	-PUW-MS24-MTB16	34.0 (1.34)	30.0 (1.18)	11.0 (0.43)	6140 (423)
M24 x 1.5	18	2.8	-PUW-MS24-MTB18	34.0 (1.34)	30.0 (1.18)	11.0 (0.43)	5670 (392)
M24 x 1.5	20	3.0	-PUW-MS24-MTB20	34.0 (1.34)	30.0 (1.18)	11.0 (0.43)	5110 (352)
M27 x 2	14	2.5	-PUW-MS27-MTB14	34.0 (1.34)	32.0 (1.26)	14.0 (0.55)	6280 (433)
M27 x 2	16	2.8	-PUW-MS27-MTB16	34.0 (1.34)	32.0 (1.26)	14.0 (0.55)	6140 (423)
M27 x 2	18	2.8	-PUW-MS27-MTB18	34.0 (1.34)	32.0 (1.26)	14.0 (0.55)	5670 (392)
M27 x 2	20	3.0	-PUW-MS27-MTB20	40.0 (1.57)	32.0 (1.26)	14.0 (0.55)	5110 (352)
M27 x 2	22	3.0	-PUW-MS27-MTB22	40.0 (1.57)	32.0 (1.26)	14.0 (0.55)	4620 (319)
M30 x 2	22	3.0	-PUW-MS30-MTB22	40.0 (1.57)	35.0 (1.38)	18.0 (0.71)	4620 (319)
M30 x 2	25	3.5	-PUW-MS30-MTB25	45.0 (1.77)	35.0 (1.38)	18.0 (0.71)	4730 (326)
M33 x 2	28	4.0	-PUW-MS33-MTB28	45.0 (1.77)	41.0 (1.61)	18.0 (0.71)	5160 (356)
M36 x 2	30	4.0	-PUW-MS36-MTB30	45.0 (1.77)	41.0 (1.61)	18.0 (0.71)	4760 (328)

Male Pipe to Tube Butt Weld

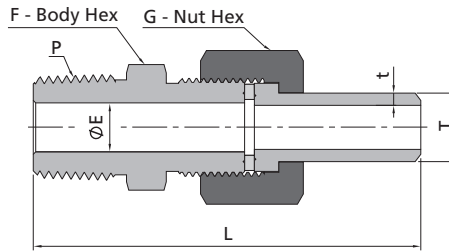

NPT Thread				Metric Tube				
P-NPT Size	T-Tube O.D. (mm)	t-Wall Thickness (mm)	Basic Ordering Number	Dimensions, mm (in.)				Working Pressure psig (bar)
				L	F	G	E	
1/8	14	2.5	-MUW-NS2-MTB14	69.0 (2.72)	19.0 (0.75)	22.0 (0.87)	4.8 (0.19)	6280 (433)
1/4	6	1.8	-MUW-NS4-MTB6	60.0 (2.36)	14.0 (0.55)	14.0 (0.55)	3.0 (0.12)	8240 (566)
1/4	8	1.8	-MUW-NS4-MTB8	73.2 (2.88)	14.0 (0.55)	16.0 (0.63)	4.0 (0.16)	8240 (566)
1/4	10	2.2	-MUW-NS4-MTB10	73.2 (2.88)	15.0 (0.59)	18.0 (0.71)	6.0 (0.24)	8160 (563)
1/4	12	2.2	-MUW-NS4-MTB12	73.2 (2.88)	18.0 (0.71)	22.0 (0.87)	7.0 (0.28)	6470 (446)
1/4	14	2.5	-MUW-NS4-MTB14	73.2 (2.88)	19.0 (0.75)	22.0 (0.87)	7.1 (0.28)	6280 (433)
1/4	16	2.8	-MUW-NS4-MTB16	73.2 (2.88)	22.0 (0.87)	25.0 (0.98)	7.1 (0.28)	6140 (423)
1/4	18	2.8	-MUW-NS4-MTB18	74.2 (2.92)	24.0 (0.94)	27.0 (1.06)	7.1 (0.28)	5670 (392)
3/8	14	2.5	-MUW-NS6-MTB14	73.2 (2.88)	19.0 (0.75)	22.0 (0.87)	9.7 (0.38)	6280 (433)
1/2	12	2.2	-MUW-NS8-MTB12	78.0 (3.07)	18.0 (0.71)	22.0 (0.87)	7.0 (0.28)	6470 (446)
1/2	14	2.5	-MUW-NS8-MTB14	78.0 (3.07)	19.0 (0.75)	22.0 (0.87)	9.0 (0.35)	6280 (433)
1/2	16	2.8	-MUW-NS8-MTB16	78.0 (3.07)	22.0 (0.87)	25.0 (0.98)	10.0 (0.39)	6140 (423)
1/2	22	3.0	-MUW-NS8-MTB22	82.0 (3.23)	30.0 (1.18)	32.0 (1.26)	11.9 (0.47)	4620 (319)
1/2	25	2.8	-MUW-NS8-MTB25	86.0 (3.39)	32.0 (1.26)	35.0 (1.38)	11.9 (0.47)	4730 (326)
1	25	3.5	-MUW-NS16-MTB25	103.0 (4.06)	35.0 (1.38)	35.0 (1.38)	17.0 (0.67)	4730 (326)

Ordering Number Description

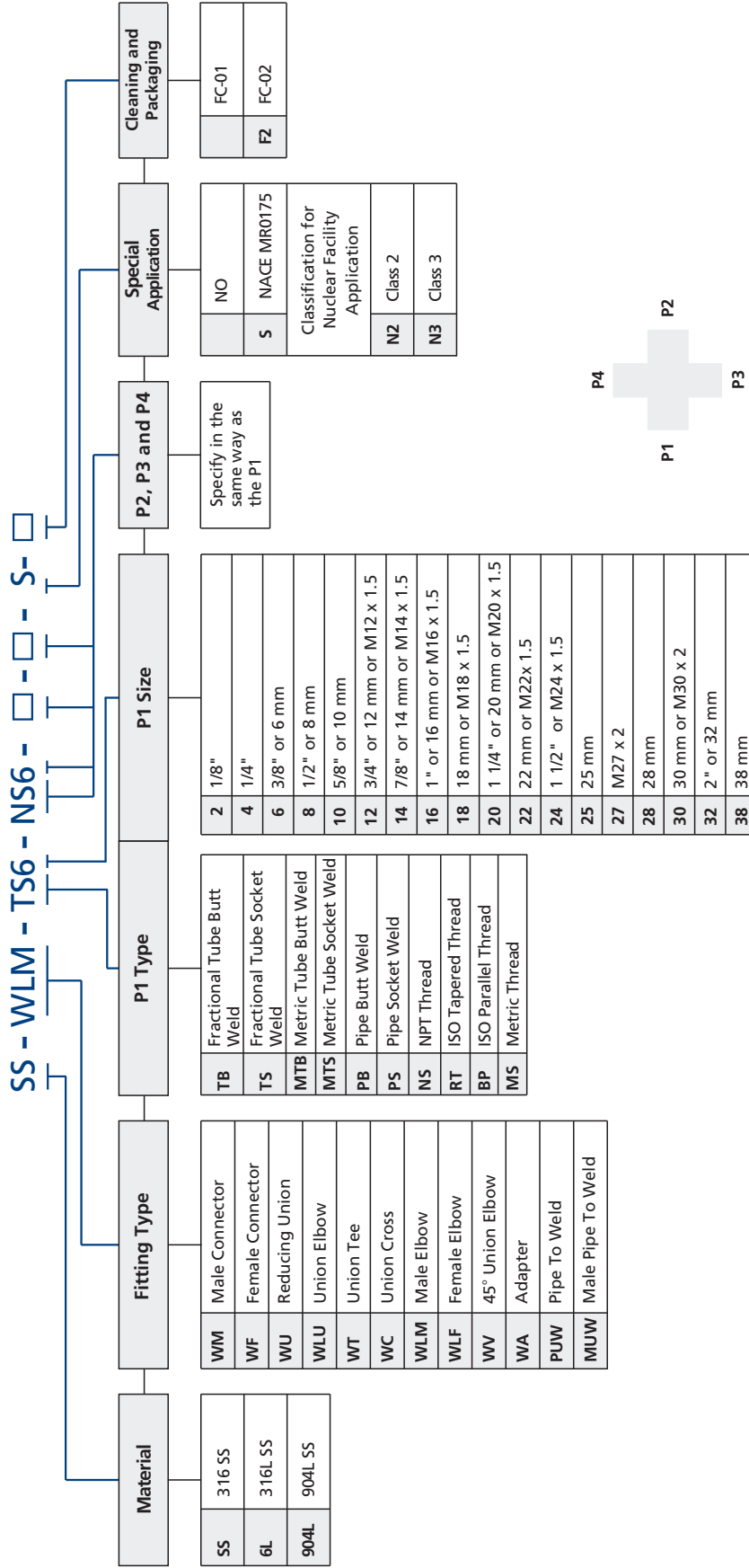

Note: "Ordering Number Description" is a reference to understand the combination rules of FITOK product part number. Not all combinations are available.

P1, P2, P3 and P4 shall be described in the following orders:

- ☉ Pipe thread connection type after weld connection type ("PUW" and "MUW" excluded)
- ☉ Pipe Butt Weld - Tube Butt Weld - Pipe Socket Weld - Tube Socket Weld - Others
- ☉ Describe in descending order as per size if the end connection types are the same
- ☉ Describe the end of P1 if all end connections are the same

Cleaning and Packaging:

- FC-01: Standard cleaning and packaging for general industrial procedures
- FC-02: Special cleaning and packaging for wetted system components to ensure compliance with product cleanliness requirement as stated in ASTM G93 Level C

info@fitokgroup.com
www.fitokgroup.com

FK-IC-GF-03-EN-181109

Ball Valves

BF, BFH, BG, BH, BO, BP, BR,
BV, BK and BU Series

Ball Valves
Plug Valves

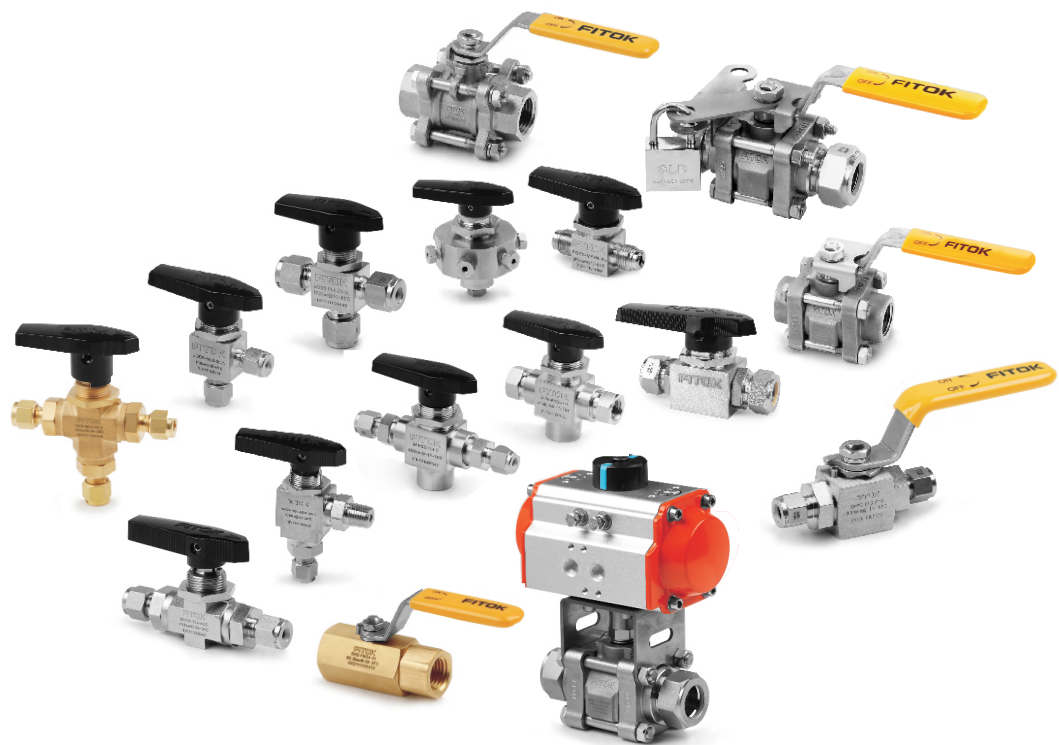

Contents

Trunnion Ball Valves

BF and BFH Series



B-04

3-piece Ball Valves

BG Series



B-11

3-piece Ball Valves

BH Series



B-16

One-piece Instrumentation Ball Valves

BO Series



B-22

Bar Stock Ball Valves

BP Series



B-36

Hex Bar Stock Ball Valves

BR Series



B-42

High Performance Ball Valves

BV Series



B-46

High Temperature Metal-seated Ball Valves

BK Series

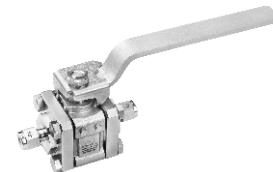

B-55

Alternative Fuel Service (AFS) Ball Valves

BU Series



B-59

Important Information about Ball Valves

- ⦿ FITOK ball valves are designed to be used in fully open or fully closed position.
- ⦿ Packing adjustment may be required during the valve's life (except for BF and BFH series).
- ⦿ For better quality maintenance, FITOK ball valves should be kept in fully open position in warehouse.
- ⦿ Valves that have not been cycled for a period of time may have a higher initial actuation torque.

Trunnion Ball Valves

BF and BFH Series

Features

- ⦿ Working pressure up to: 10,000 psig (690 bar)
- ⦿ Working temperature: 0°F to 450°F (-18°C to 232°C)
- ⦿ Orifice size: 0.19" (4.8 mm)
- ⦿ Fixed ball with double sealing
- ⦿ Trunnion-style ball to prevent ball blowout
- ⦿ Automatic compensation of seat sealing
- ⦿ Low operating torque
- ⦿ Blowout proof stem
- ⦿ Handle as indicator of flow direction
- ⦿ Positive handle stop
- ⦿ Handle color options available
- ⦿ Pneumatic and electric actuator available
- ⦿ Panel mountable
- ⦿ Leak-tight performance testing with nitrogen or compressed air for every valve at the rated pressure (not higher than 6000 psig) to meet the requirement of no visible leak
- ⦿ Compact maximum-flow design
- ⦿ 2- or 3-way flow patterns
- ⦿ Spring-load seats to provide leak tight integrity in both low-and high-pressure systems and reduce seat wear from pressure surges
- ⦿ The inlet of 3-way valve can be any port
- ⦿ Low-temperature service option available
- ⦿ BF series 3-way ball valves for "fast fill" CNG filling station application available
- ⦿ BF series ball valves with ECE R110 type approval available



Pressure vs. Temperature

BF Series

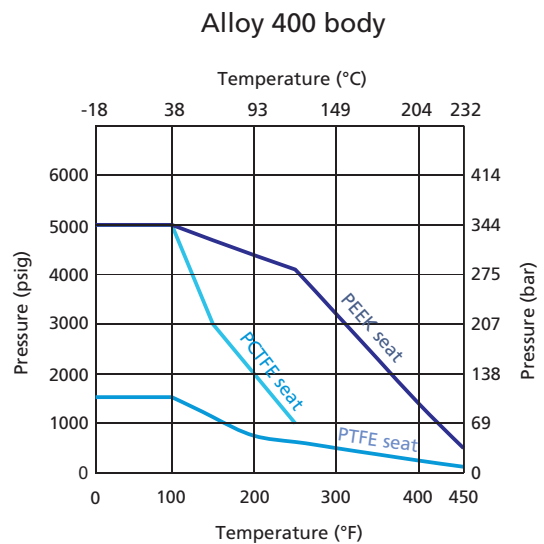
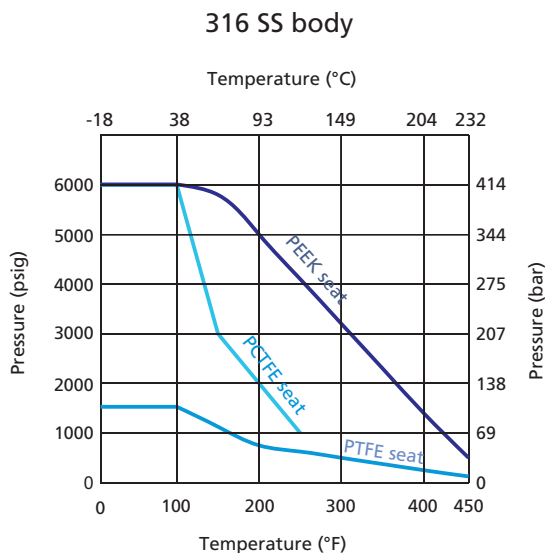

BFH Series

316 SS body

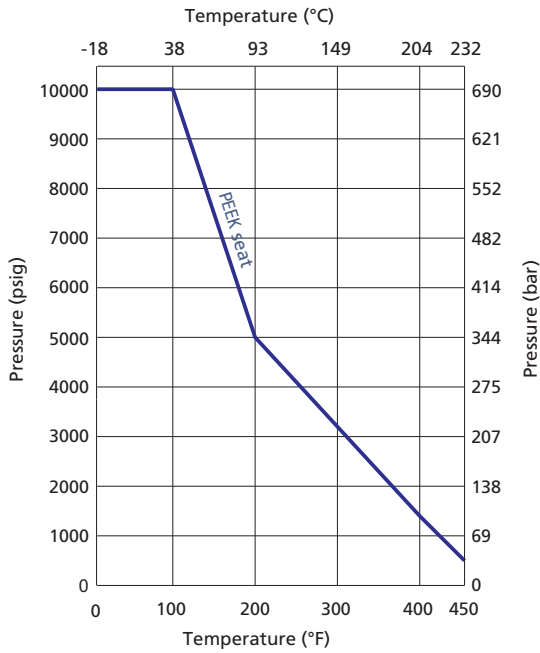

Pressure Rating @ 100°F (38°C)

Material	End Connection	Pressure Rating, psig (bar)
316 SS	FNS2, FNS4 FL4, ML6	10000 (690)
	ML10	8400 (578)
	FL6/ML8	7500 (516)
	FL8	6700 (461)
	ML12	6800 (470)

Note: Maximum working pressure of BFH Series ball valves is 10,000 psig. The specified pressure rating is restricted by end connections.

Ball Valves
Plug Valves

Standard Materials of Construction

BF Series

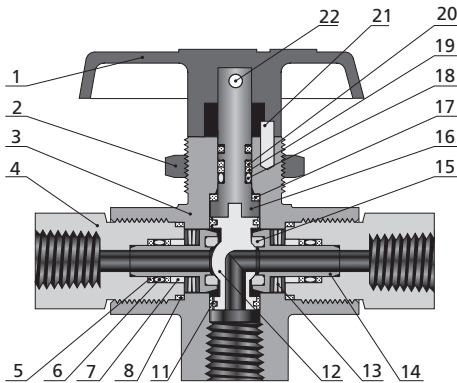
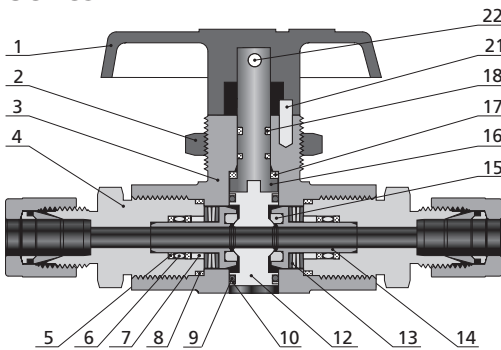

Item	Component	Valve Body Material			
		316 SS		Alloy 400	
		2-way	3-way	2-way	3-way
Material Grade/ASTM Specification					
1	Handle	Nylon with SS insert			
2	Panel Nut	316 SS/A479			
3	Body	<i>F316 SS/A182</i>		<i>Alloy 400/B164</i>	
4	End Connection	<i>316 SS/A479</i>		<i>Alloy 400/B164</i>	
5	Seat Retainer Backup Ring	<i>Reinforced PTFE</i>			
6	Seat Retainer O-ring	<i>Fluorocarbon FKM</i>			
7	Seat Retainer Guide	<i>316 SS/A479</i>		<i>Alloy 400/B164</i>	
8	End Connection Seal	<i>Silver-plated 316L/A269</i>			
9	Trunnion O-ring	<i>Fluorocarbon FKM</i>	—	<i>Fluorocarbon FKM</i>	—
10	Trunnion Backup Ring	<i>Reinforced PTFE</i>	—	<i>Reinforced PTFE</i>	—
11	Trunnion Bearing	—	<i>PEEK</i>	—	<i>PEEK</i>
12	Ball	<i>316 SS/A479</i>	<i>S21800/A479</i>	<i>Alloy 400/B164</i>	
13	Seat Spring	<i>Alloy X-750/AMS 5542</i>			
14	Seat Retainer	<i>316 SS/A479</i>		<i>Alloy 400/B164</i>	
15	Seat	<i>PTFE or PEEK or PCTFE</i>			
16	Stem	<i>316 SS/A479</i>		<i>Alloy 400/B164</i>	
17	Stem Washer	<i>PEEK</i>			
18	Stem O-ring	<i>Fluorocarbon FKM</i>	<i>Fluorocarbon FKM</i>	<i>Fluorocarbon FKM</i>	<i>Fluorocarbon FKM</i>
19	Secondary Stem Backup Ring	—	<i>PTFE/D1710</i>	—	<i>PTFE/D1710</i>
20	Primary Stem Backup Ring	—	<i>PEEK</i>	—	<i>PEEK</i>
21	Stop Pin	<i>SS</i>			
22	Set Screw	<i>Galvanized carbon steel</i>			
<i>Lubricants</i>		<i>Fluorinated-based</i>			

Note: Wetted components are listed in italics.

- Ball trunnions are PTFE coated for BF series 2-way valves.
- For other materials, please contact FITOK Group or our authorized distributors.

BFH Series

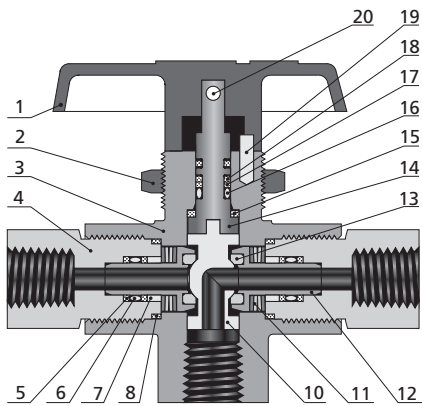
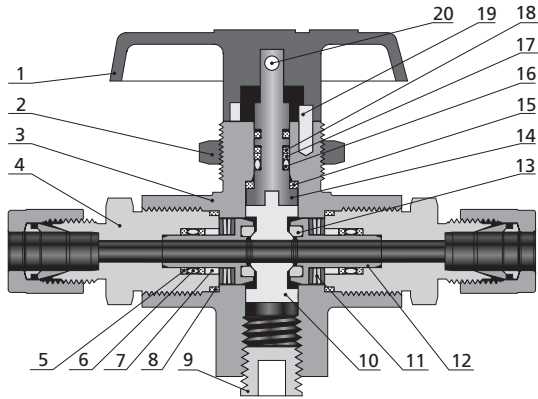

Item	Component	2-way	3-way
		Material Grade/ASTM Specification	
1	Handle	<i>Nylon with SS insert</i>	
2	Panel Nut	<i>316 SS/A479</i>	
3	Body	<i>316 SS/A182</i>	
4	End Connection	<i>316 SS/A479</i>	
5	Seat Retainer Backup Ring	<i>Reinforced PTFE</i>	
6	Seat Retainer O-ring	<i>Fluorocarbon FKM</i>	
7	Seat Retainer Guide	<i>316 SS/A479</i>	
8	End Connection Seal	<i>Silver-plated 316L/A269</i>	
9	Plug	<i>316 SS/A479</i>	
10	Ball	<i>S21800/A479</i>	
11	Seat Spring	<i>Alloy X-750/AMS 5542</i>	
12	Seat Retainer	<i>316 SS/A479</i>	
13	Seat	<i>PEEK</i>	
14	Stem	<i>316 SS/A479</i>	
15	Stem Washer	<i>PEEK</i>	
16	Stem O-ring	<i>Fluorocarbon FKM</i>	
17	Secondary Stem Backup Ring	<i>PTFE/D1710</i>	
18	Primary Stem Backup Ring	<i>PEEK</i>	
19	Stop Pin	<i>SS</i>	
20	Set Screw	<i>Galvanized carbon steel</i>	
Lubricants		<i>Fluorinated-based</i>	

Note: Wetted components are listed in italics.

1. Ball trunnions are PTFE coated for BFH series ball valves.

2. For other materials, please contact FITOK Group or our authorized distributors.

Dimensions

2-way Valves

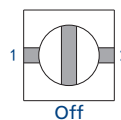
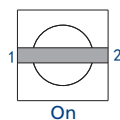
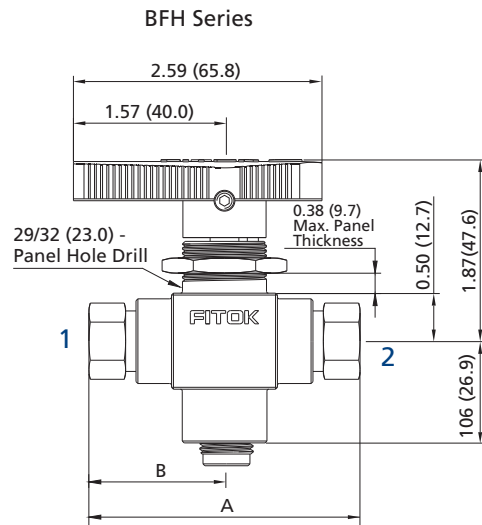
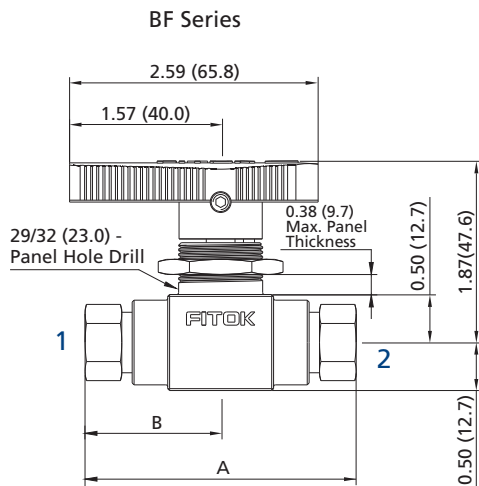

Basic Ordering Number		Connection Type and Size		Orifice in. (mm)	Cv	Dimensions, in. (mm)	
BF Series	BFH Series	Connection 1/2				A	B
BF□□-FNS2	BFH□□-FNS2-P	1/8 Female NPT		0.19 (4.8)	1.2	2.94 (74.7)	1.47 (37.3)
BF□□-FNS4	BFH□□-FNS4-P	1/4 Female NPT					
BF□□-FNS8	BFH□□-FNS4-P	1/2 Female NPT			1.0	3.93 (99.8)	1.97 (50.0)
BF□□-FL4	BFH□□-FL4-P	1/4" FITOK			1.2	4.25 (108.0)	2.13 (54.1)
BF□□-FL6	BFH□□-FL6-P	3/8" FITOK			1.6	4.14 (105.2)	2.07 (52.6)
BF□□-FL8	BFH□□-FL8-P	1/2" FITOK			1.4	4.39 (111.5)	2.19 (55.6)
BF□□-ML6	BFH□□-ML6-P	6 mm FITOK			1.0	4.60 (116.8)	2.30 (58.4)
BF□□-ML8	BFH□□-ML8-P	8 mm FITOK			1.6	4.14 (105.2)	2.07 (52.6)
BF□□-ML10	BFH□□-ML10-P	10 mm FITOK			1.5	4.15 (105.4)	2.07 (52.6)
BF□□-ML12	BFH□□-ML12-P	12 mm FITOK			1.3	4.41 (112.0)	2.20 (55.9)
					1.0	4.60 (116.8)	2.30 (58.4)

3-way Valves

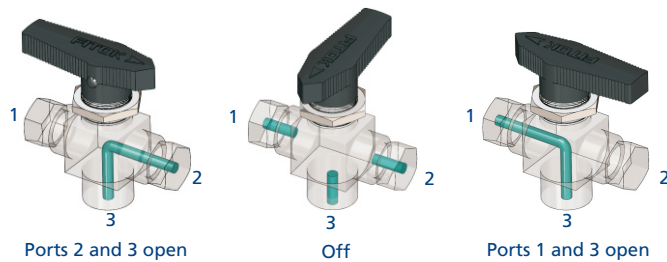
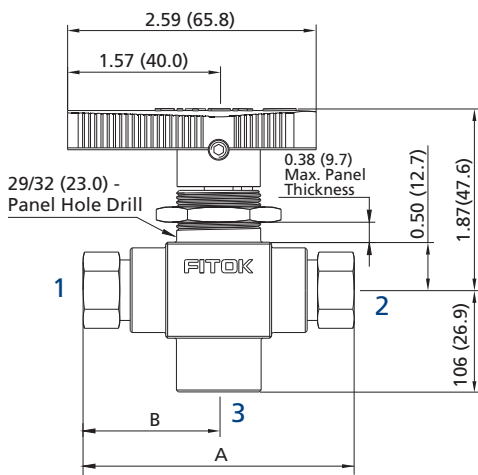

Basic Ordering Number		Connection Type and Size		Orifice in. (mm)	Cv	Dimensions, in. (mm)	
BF Series	BFH Series	Connection 1/2	Connection 3			A	B
BF□□-FNS2-3	BFH□□-FNS2-P-3	1/8 Female NPT	1/4 Female NPT	0.19 (4.8)	0.75	2.94 (74.7)	1.47 (37.3)
BF□□-FNS4-3	BFH□□-FNS4-P-3	1/4 Female NPT					
BF□□-FL4-3	BFH□□-FL4-P-3	1/4" FITOK				3.93 (99.8)	1.97 (50.0)
BF□□-FL6-3	BFH□□-FL6-P-3	3/8" FITOK				4.14 (105.2)	2.07 (52.6)
BF□□-FL8-3	BFH□□-FL8-P-3	1/2" FITOK				4.39 (111.5)	2.19 (55.6)
BF□□-ML6-3	BFH□□-ML6-P-3	6 mm FITOK				4.60 (116.8)	2.30 (58.4)
BF□□-ML8-3	BFH□□-ML8-P-3	8 mm FITOK				4.14 (105.2)	2.07 (52.6)
BF□□-ML10-3	BFH□□-ML10-P-3	10 mm FITOK				4.15 (105.4)	2.07 (52.6)
BF□□-ML12-3	BFH□□-ML12-P-3	12 mm FITOK				4.41 (112.0)	2.20 (55.9)
						4.60 (116.8)	2.30 (58.4)

1. FITOK means FITOK double ferrule tube fittings.
2. Sizes and types listed are standard. Other sizes and types are available upon request, please contact FITOK Group or our authorized distributors.
3. Dimensions are shown with tube fitting nuts finger-tightened. All dimensions are for reference only and are subject to change.
For dimensions not shown above, please contact FITOK Group or our authorized distributors.
4. Bottom port of all 3-way valves is 1/4 in. female NPT.

Special Application Ball Valves

Low-Temperature Service

BF and BFH series ball valves for low-temperature service, with a temperature rating of -40°F to 200°F (-40°C to 93°C), are available.

Low-temperature service valves have low-temperature NBR O-rings. All other materials are the same as those of standard valves. To order a valve for low-temperature service, add -LT into the valve ordering number.

For example: BFSS-FL4-P-LT

BFSS-FL4-P-3-LT

Seal kit for field replacement is available, see "Seal Kits" in Page B-09.

Low-Temperature Service BF Series Pressure vs. Temperature

316 SS Body

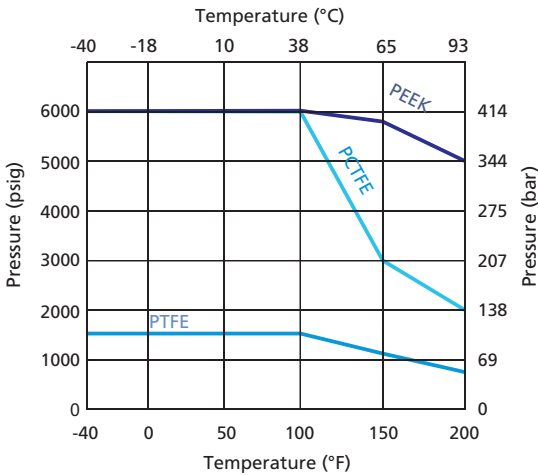

Alloy 400 Body

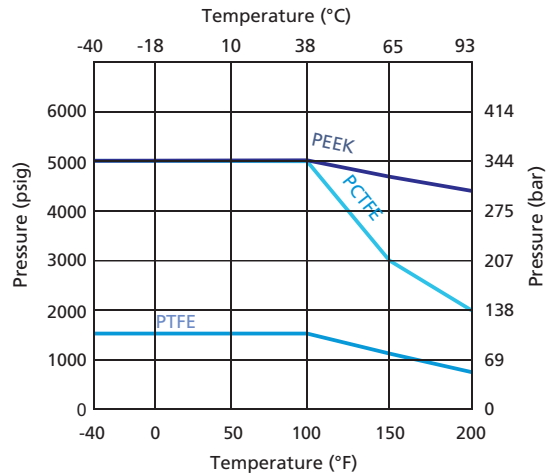

Low-Temperature Service BFH Series Pressure vs. Temperature

316 SS Body

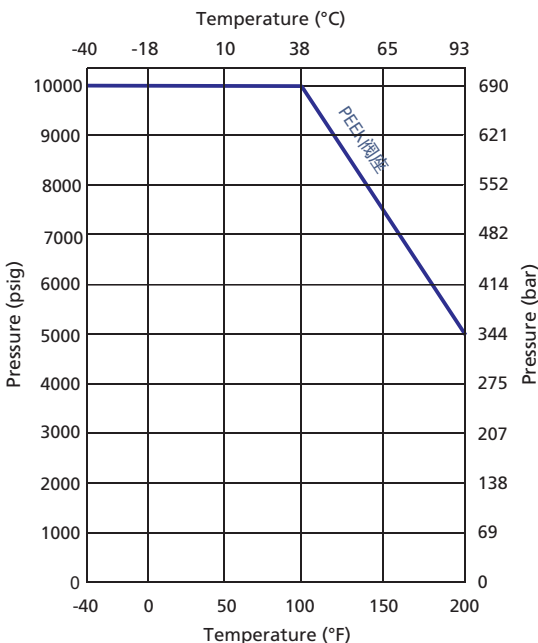

Note: The maximum working pressure for BFH series low-temperature service ball valves is the same as that of standard ball valves.

"Fast Fill" CNG Filling Station Application

BF series 3-way valves for use in "fast-fill" CNG filling station as well as a variety of filling station applications are available.

Features

- A directional installation with 90 degree actuation for ease of operation during filling
 - 3-way design with vent port for ease of venting after fill
 - PEEK seats to reduce maintenance required in high-cycle applications
 - Cycle life test report available upon request
 - Field repairable with seal kit, see "Seal Kits" on Page B-09
- To order, the flow pattern designator should be specified as "3DL" in the valve ordering number.

Example: BFSS-FNS4-P-3DL (The material and pressure vs. temperature curve are the same with those of BF series standard valves.)
 BFSS-FNS4-P-3DL-LT (The material and pressure vs. temperature curve are the same with those of BF series low-temperature service valves.)

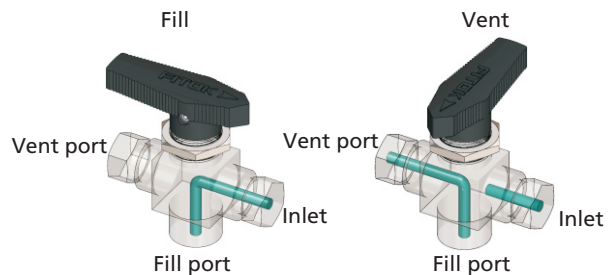

CNG/NGV Application

BF series ball valves with ECE R110 manual valve type approval available.

Classification: Class 0

Temperature rating: -40°F to 248°F (-40°C to 120°C)

Pressure rating: 3370 psig (260 bar)

CNG/NGV application valves have low-temperature FKM O-rings and PEEK seats. All other materials are the same as those of standard valves.

To order a valve for CNG/NGV application, add **-R110** into the valve ordering number.

For example: BFSS-FL4-P-**R110**

BFSS-FL4-P-3-**R110**

Seal kit for field replacement is available, see "Seal Kits" in Page B-09.

Seal Kits

Valve Series	Flow Pattern	Special Application	Basic Seal Kit Ordering Number	Content
BF	2-way	/	BFSS-2-□	Seat retainer backup ring, seat retainer O-ring, seat retainer guide, end connection seal, trunnion O-ring, trunnion backup ring, ball, seat spring, seat retainer, seat, stem, stem washer, stem O-ring, instructions.
		Low-temperature service	BFSS-2-□-LT	
		CNG/NGV application	BFSS-2-P-R110	
	3-way	/	BFSS-3-□	Seat retainer backup ring, seat retainer O-ring, seat retainer guide, end connection seal, trunnion bearing, ball, seat spring, seat retainer, seat, stem, stem washer, stem O-ring, secondary stem backup ring, primary stem backup ring, instructions.
		Low-temperature service	BFSS-3-□-LT	
		"Fast Fill" CNG filling station application	BFSS-3DL-P	
CNG/NGV application		BFSS-3DL-P-LT		
BFH	2-way	/	BFHSS-2-P	Seat retainer backup ring, seat retainer O-ring, seat retainer guide, end connection seal, ball, seat spring, seat retainer, seat, stem, stem washer, stem O-ring, secondary stem backup ring, primary stem backup ring, instructions.
		Low-temperature service	BFHSS-2-P-LT	
	3-way	/	BFHSS-3-P	
		Low-temperature service	BFHSS-3-P-LT	

Seat Material	Designator
PTFE	T
PCTFE	K
PEEK	P

To order seal kits for BF series standard and low-temperature service ball valves, select a seat designator from the table at left and add to the basic seal kit ordering number.

Example: BFSS-2-T
BFSS-2-P-LT

Ordering numbers specify 316 stainless steel material. For other materials, replace SS in the ordering numbers with other material designators.

Example: BFM-2-T. M is the designator for Alloy 400.

Ordering Number Description

BFSS - FNS4 - ML12 - P - RXHQ3 - SCEF2

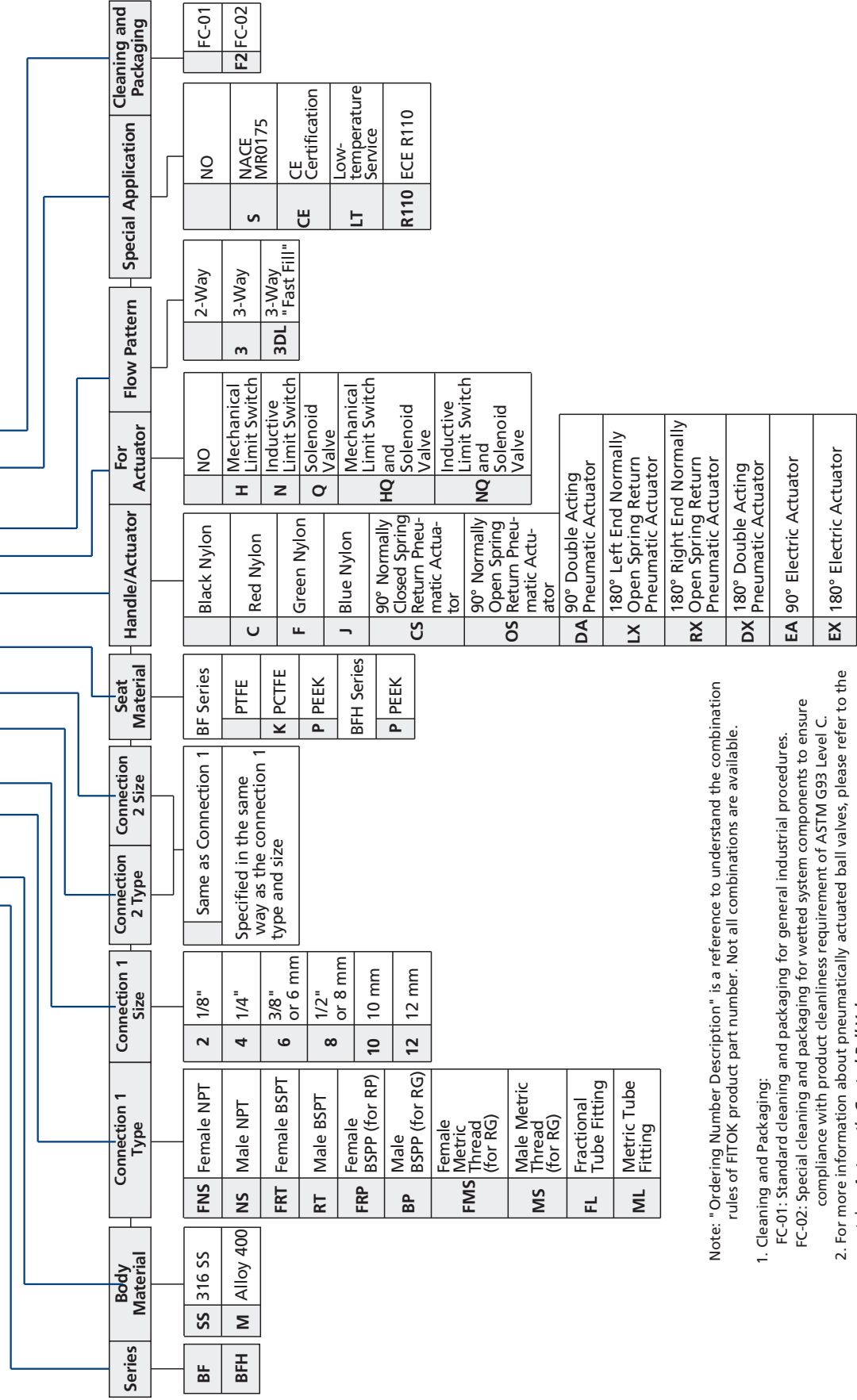

Note: " Ordering Number Description" is a reference to understand the combination rules of FITOK product part number. Not all combinations are available.

- Cleaning and Packaging:
 FC-01: Standard cleaning and packaging for general industrial procedures.
 FC-02: Special cleaning and packaging for wetted system components to ensure compliance with product cleanliness requirement of ASTM G93 Level C.
- For more information about pneumatically actuated ball valves, please refer to the catalog **Automatic Control Ball Valves**.
- CE certification is available. For more information, please contact FITOK group or our authorized distributors.
- Certifications do not include attachments to the valve, such as actuators or a different handle mechanism.

3-piece Ball Valves

BG Series

Features

- ⦿ Working pressure up to: 1000 psig (69.0 bar)
- ⦿ Working temperature: -20°F to 450°F (-28°C to 232°C)
- ⦿ End connections:
 - 1/8 to 1 thread
 - 1/8" to 1" pipe butt or socket weld
 - 1/4" to 1" and 6 mm to 25 mm tube butt or socket weld
 - 1/4" to 1" and 6 mm to 25 mm tube fitting
- ⦿ Orifice sizes: 0.19" (4.8 mm) to 1" (25 mm)
- ⦿ Blowout proof stem
- ⦿ Bidirectional flow
- ⦿ Leak-tight performance testing with nitrogen or compressed air for every valve at the rated pressure to meet the requirement of no visible leak



Pressure vs. Temperature

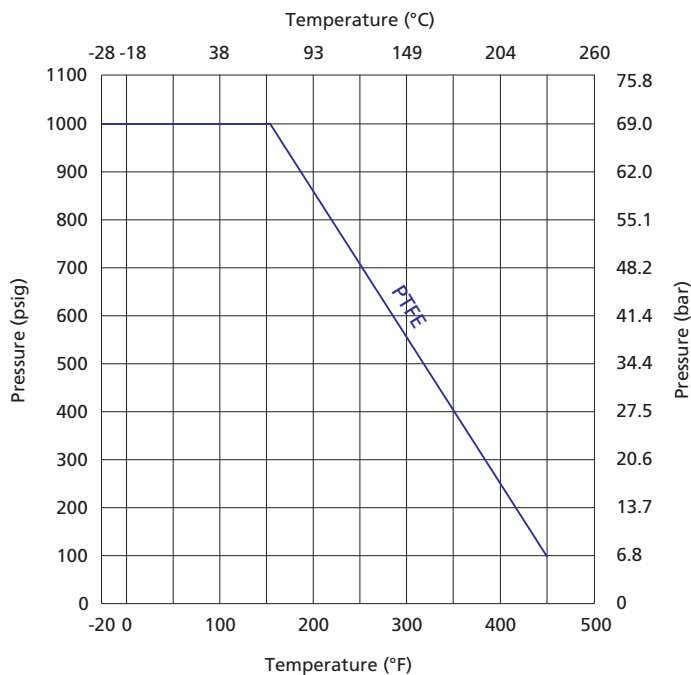

Note: The temperature and pressure rating are based on valves of standard materials.

Standard Materials of Construction

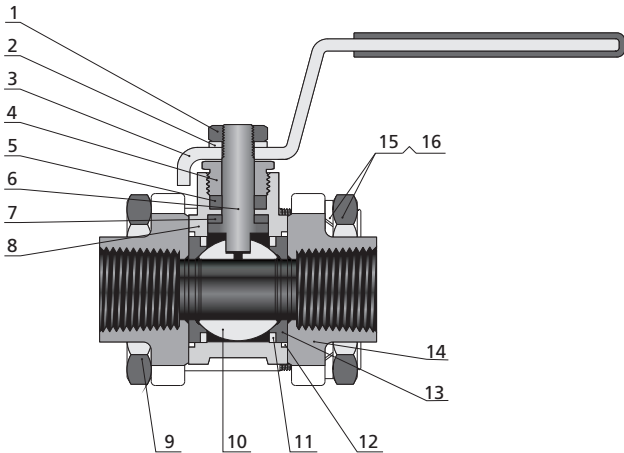

Item	Component	Valve Body Material	
		CF8M/A351	CF8/A351
1	Stem Nut	SS	
2	Gasket	SS	
3	Handle	304 SS/A240 (with vinyl sleeve)	
4	Gland	316 SS/A479 or 304 SS/A479	
5	Stem Packing	PTFE/D1710	
6	Stem	316 SS/A479 or 304 SS/A479	
7	Stem Bearing	PTFE/D1710	
8	Body	CF8M/A351	CF8/A351
9	Body Bolt	SS	
10	Ball	316 SS/A479 or 304 SS/A479	
11	Support Ring	316 SS/A240 or 304 SS/A240	
12	Flange Seal	PTFE/D1710	
13	Seat	PTFE/D1710	
14	End Connection	CF8M/A351	CF8/A351
15	Gasket	SS	
16	Nut	SS	
Lubricants		Silicone-based and PTFE-based	

Note: Wetted components are listed in italics.
For other materials, please contact FITOK Group or our authorized distributors.

Dimensions

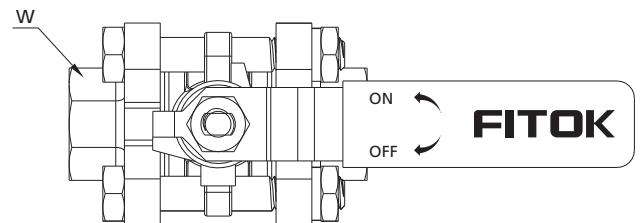
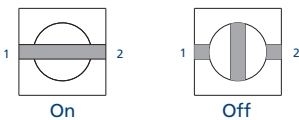
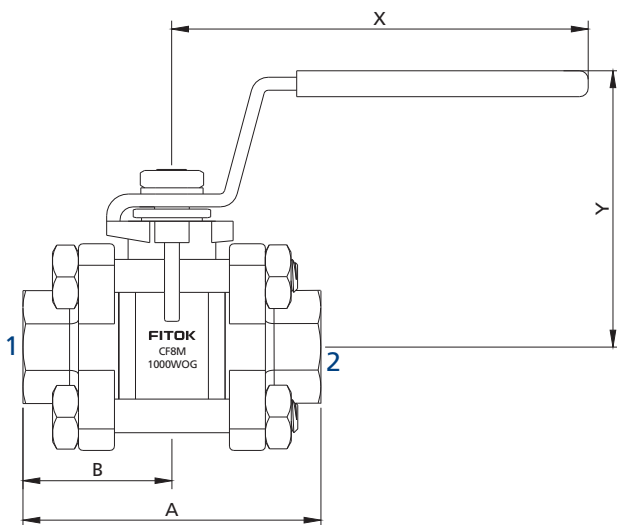

Basic Ordering Number	Connection Type and Size		Orifice in. (mm)	Cv	Dimensions, in. (mm)				
	Connection 1	Connection 2			A	B	W	X	Y
BG□□-FNS2-05	1/8 Female NPT	1/8 Female NPT	0.19 (4.8)	1.2	2.05 (52.1)	1.03 (26.0)	0.63 (16.0)	2.69 (68.3)	1.46 (37.0)
BG□□-FRP2-05	1/8 Female BSPP	1/8 Female BSPP							
BG□□-PB4-05	1/4 PB, Schedule Number: 80	1/4 PB, Schedule Number: 80							
BG□□-FL4-05	1/4" FITOK	1/4" FITOK							
BG□□-ML6-05	6 mm FITOK	6 mm FITOK							
BG□□-ML8-05	8 mm FITOK	8 mm FITOK							
BG□□-FNS4-07	1/4 Female NPT	1/4 Female NPT	0.28 (7.1)	3.8	2.05 (52.1)	1.03 (26.0)	0.93 (23.5)	3.94 (100.0)	2.19 (55.7)
BG□□-FRP4-07	1/4 Female BSPP	1/4 Female BSPP							
BG□□-FL6-07	3/8" FITOK	3/8" FITOK							
BG□□-ML10-07	10 mm FITOK	10 mm FITOK							
BG□□-FL8-11	1/2" FITOK	1/2" FITOK	0.42 (10.6)	7.5	4.04 (103.0)	2.02 (51.3)			
BG□□-ML12-11	12 mm FITOK	12 mm FITOK							
BG□□-ML14-11	14 mm FITOK	14 mm FITOK							
BG□□-FNS6-13	3/8 Female NPT	3/8 Female NPT	0.50 (12.7)	11.3	2.57 (65.2)	1.28 (32.6)	0.93 (23.5)	3.94 (100.0)	2.19 (55.7)
BG□□-FRP6-13	3/8 Female BSPP	3/8 Female BSPP							
BG□□-PS6-13	3/8 PS	3/8 PS							
BG□□-PB8-13	1/2 PB, Schedule Number: 80	1/2 PB, Schedule Number: 80							
BG□□-FL10-13	5/8" FITOK	5/8" FITOK							
BG□□-ML16-13	16 mm FITOK	16 mm FITOK							
BG□□-FNS8-15	1/2 Female NPT	1/2 Female NPT	0.55 (14.0)	13.0	2.74 (69.5)	1.37 (34.8)	1.06 (27.0)	3.94 (100.0)	2.26 (57.5)
BG□□-FRP8-15	1/2 Female BSPP	1/2 Female BSPP							
BG□□-PS8-15	1/2 PS	1/2 PS							
BG□□-MTB22-15	22 mm MTB, tube wall thickness: 3 mm	22 mm MTB, tube wall thickness: 3 mm							
BG□□-TS12-15	3/4" TS	3/4" TS							
BG□□-MTS18-15	18 mm MTS	18 mm MTS							
BG□□-FL12-15	3/4" FITOK	3/4" FITOK							
BG□□-ML18-15	18 mm FITOK	18 mm FITOK							
BG□□-FNS12-20	3/4 Female NPT	3/4 Female NPT	0.79 (20.0)	50.0	3.15 (80.0)	1.57 (40.0)	1.34 (34.0)	5.18 (131.5)	2.66 (67.5)
BG□□-FRP12-20	3/4 Female BSPP	3/4 Female BSPP							

B-14 Ball Valves

Basic Ordering Number	Connection Type and Size		Orifice in. (mm)	Cv	Dimensions, in. (mm)				
	Connection 1	Connection 2			A	B	W	X	Y
BG□□-PB12-20	3/4 PB Schedule Number: 80	3/4 PB Schedule Number: 80	0.79 (20.0)	50.0	3.15 (80.0)	1.57 (40.0)	1.34 (34.0)	5.18 (131.5)	2.66 (67.5)
BG□□-PS12-20	3/4 PS	3/4 PS							
BG□□-TS16-20	1" TS	1" TS							
BG□□-MTB25-20	25 mm MTB, tube wall thickness: 3.5 mm	25 mm MTB, tube wall thickness: 3.5 mm							
BG□□-MTS25-20	25 mm MTS	25 mm MTS			5.12 (130.0)	2.56 (65.0)	1.34 (34.0)	5.18 (131.5)	2.66 (67.5)
BG□□-FL16-20	1" FITOK	1" FITOK							
BG□□-ML22-20	22 mm FITOK	22 mm FITOK							
BG□□-ML25-20	25 mm FITOK	25 mm FITOK							
BG□□-FNS16-25	1 Female NPT	1 Female NPT	0.98 (25.0)	93.0	3.54 (90.0)	1.77 (45.0)	1.57 (40.0)	5.95 (151.2)	3.08 (78.2)
BG□□-FRP16-25	1 Female BSPP	1 Female BSPP							
BG□□-PS16-25	1 PS	1 PS							
BG□□-PB16-25	1 PB Schedule Number: 80	1 PB Schedule Number: 80							

1. FITOK means FITOK double ferrule tube fittings, TS means fractional tube socket weld, MTS means metric tube socket weld, TB means fractional tube butt weld, MTB means metric tube butt weld, PS means pipe socket weld, and PB means pipe butt weld.
2. Sizes and types listed are standard. Other sizes and types are available upon request, please contact FITOK Group or our authorized distributors.
3. Dimensions are shown with tube fitting nuts finger-tightened. All dimensions are for reference only and are subject to change. For dimensions not shown above, please contact FITOK Group or our authorized distributors.

Ordering Number Description

BGSS - FNS8 - ML18 - 15 - L - SF2

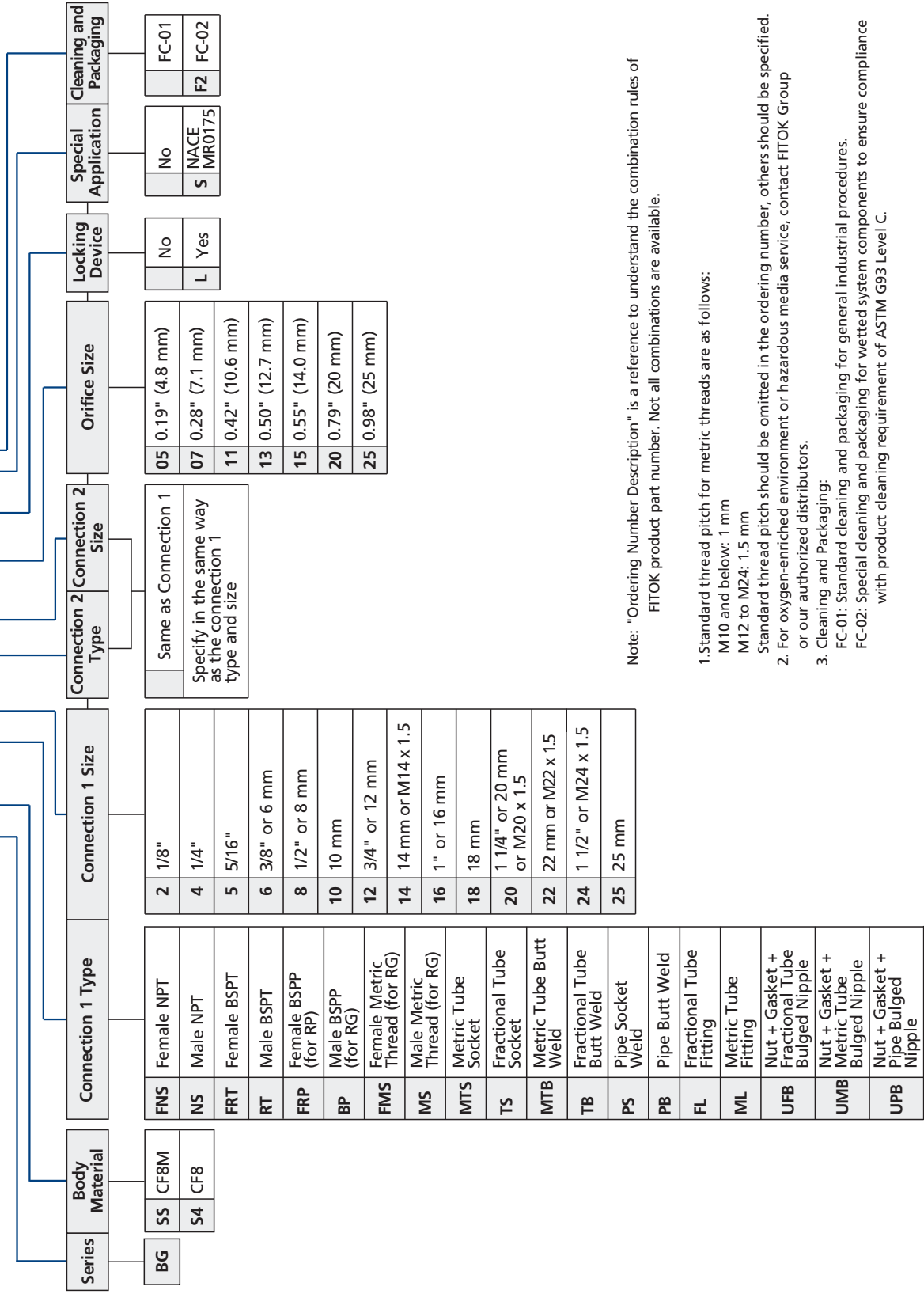

Note: "Ordering Number Description" is a reference to understand the combination rules of FITOK product part number. Not all combinations are available.

- Standard thread pitch for metric threads are as follows:
M10 and below: 1 mm
M12 to M24: 1.5 mm
Standard thread pitch should be omitted in the ordering number, others should be specified.
2. For oxygen-enriched environment or hazardous media service, contact FITOK Group or our authorized distributors.
- Cleaning and Packaging:
FC-01: Standard cleaning and packaging for general industrial procedures.
FC-02: Special cleaning and packaging for wetted system components to ensure compliance with product cleaning requirement of ASTM G93 Level C.

3-piece Ball Valves

BH Series

Features

- ⦿ Working pressure up to: 3000 psig (207 bar)
- ⦿ Working temperature: -20°F to 450°F (-28°C to 232°C)
- ⦿ End connections:
 - 1/8 to 2 thread
 - 1/8" to 2" pipe butt or socket weld
 - 1/4" to 2" and 6 mm to 50 mm tube butt or socket weld
 - 1/4" to 2" and 6 mm to 38 mm tube fitting
- ⦿ 3-piece precision cast body construction
- ⦿ Orifice sizes: 0.19" (4.8 mm) to 1.5" (38.1 mm)
- ⦿ Pneumatic and electric actuator available
- ⦿ Bidirectional flow for 2-way valves
- ⦿ Bottom port as inlet for 3-way valves
- ⦿ Leak-tight performance testing with nitrogen or compressed air for every valve at the rated pressure to meet the requirement of no visible leak

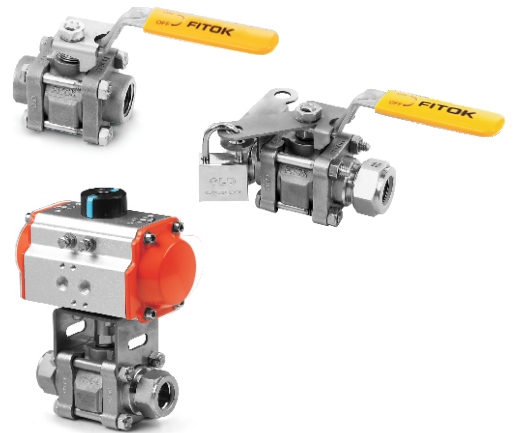

Pressure vs. Temperature

2-way Valves

Orifice Size: 0.19", 0.28", 0.41", 0.52" & 0.88"

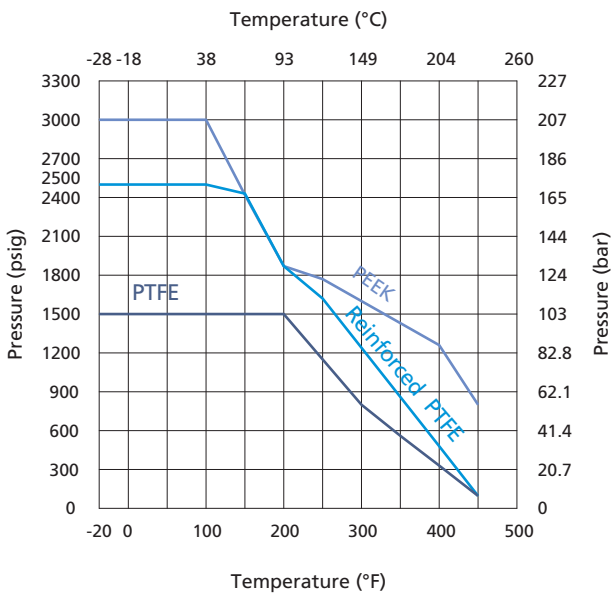

Orifice Size: 1.13", 1.25" & 1.50"

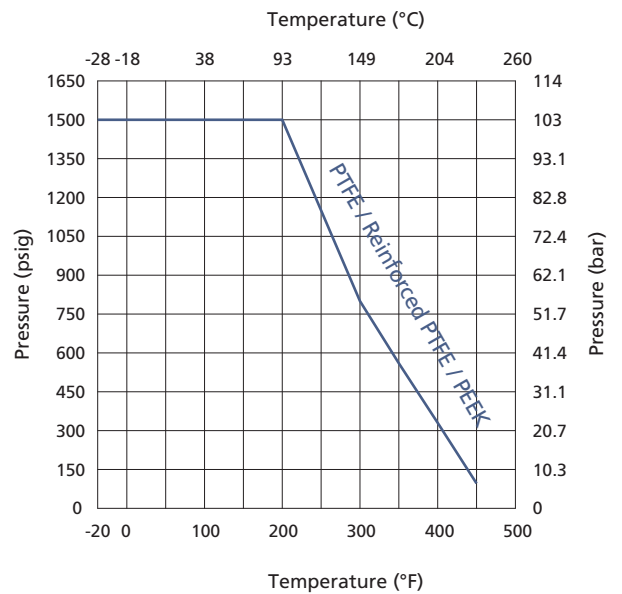

3-way Valves

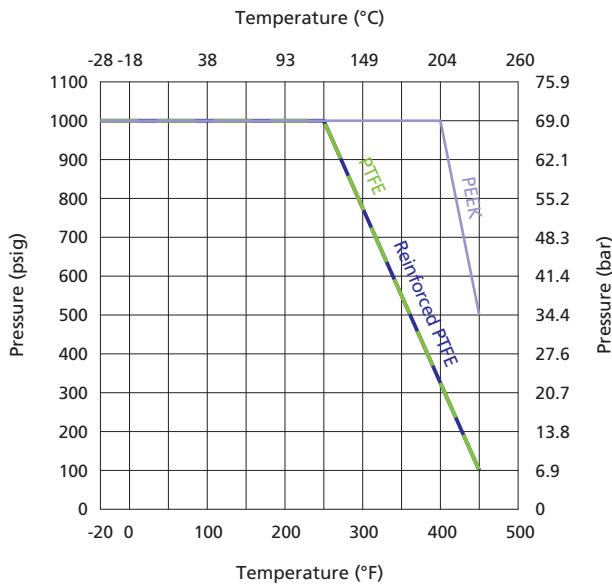

Note: The temperature and pressure rating are based on valves of standard materials.

Standard Materials of Construction

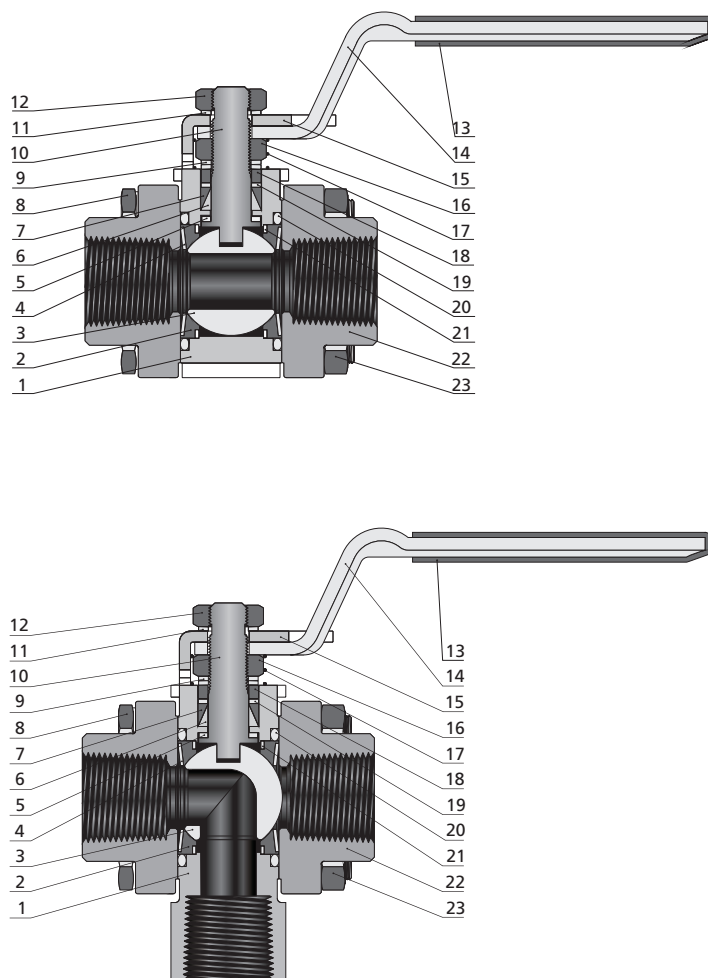

Item	Component	Material Grade/ASME Specification	
1	Body	<i>CF8M/A351</i>	<i>CF8/A351</i>
2	Seat	<i>PTFE or Reinforced PTFE or PEEK</i>	
3	Ball	<i>316 SS/A479</i>	
4	Coned-disc Spring	<i>Strain-hardened 316 SS/A240</i>	
5	Stem Bearing	<i>PEEK</i>	
6	Lower Packing	<i>Reinforced PTFE</i>	
7	Upper Packing	<i>Reinforced PTFE</i>	
8	Body Bolt	<i>Gr. B8M/A193</i>	
9	Stem Spring	<i>Strain-hardened 316 SS/A240</i>	
10	Stem	<i>316 SS/A479</i>	
11	Stem Spring	<i>Strain-hardened 316 SS/A240</i>	
12	Stem Nut	<i>Gr. 8M/A194</i>	
13	Handle Sleeve	<i>Vinyl</i>	
14	Handle	<i>304 SS/A240</i>	
15	Stop Plate	<i>304 SS/A240</i>	
16	Stem Nut	<i>Gr. 8M/A194</i>	
17	Grounding Spring	<i>302 SS/A313</i>	
18	Gland	<i>PTFE-coated 316 SS/A479</i>	
19	Packing Support	<i>PEEK</i>	
20	Flange Seal	<i>PTFE/D1710</i>	
21	Support Ring	<i>316 SS/A240</i>	
22	End Connection	<i>CF8M/A351</i>	<i>CF8/A351</i>
23	Body Nut	<i>Gr.8M/A194</i>	
	Lubricants	<i>Silicone-based and PTFE-based</i>	

Note: Wetted components are listed in italics. For other materials, please contact FITOK Group or our authorized distributors.

Dimensions

2-way Valves

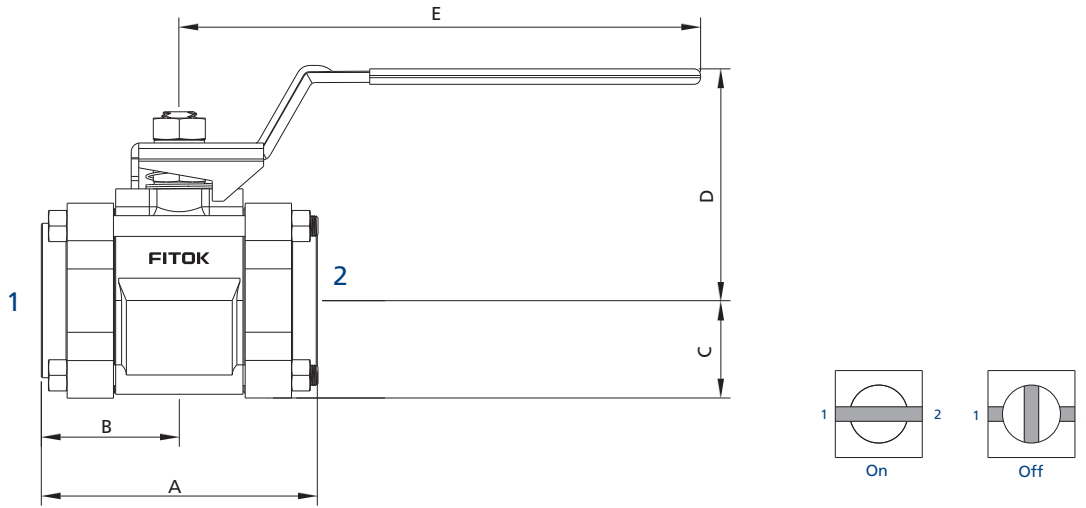

3-way Valves

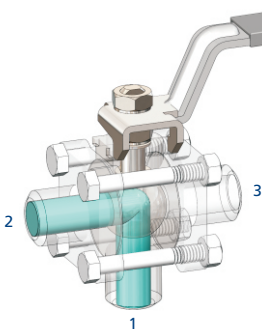
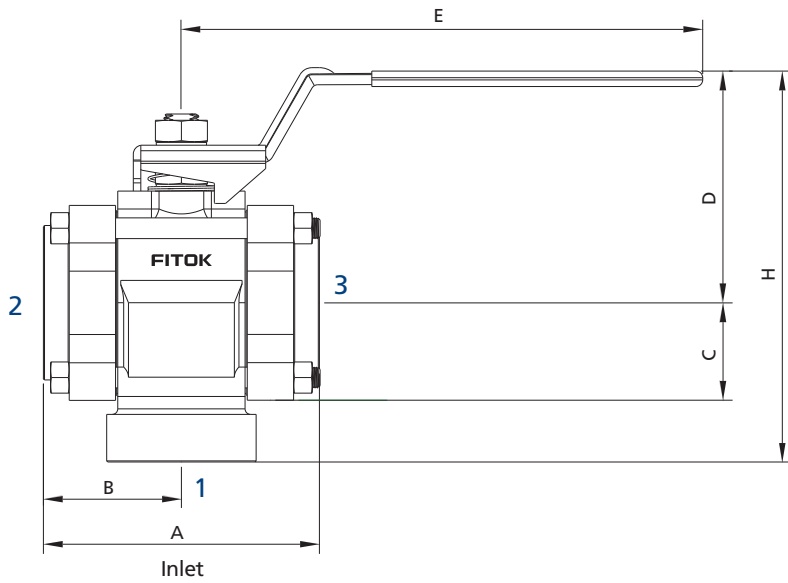

Port 1 to port 2

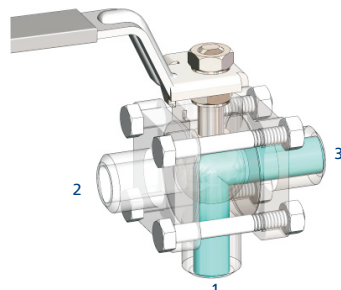

Port 1 to port 3

Basic Ordering Number		Connection Type and Size		Orifice in. (mm)	Cv	Dimensions, in. (mm)												
2-way	3-way	Connection 1	Connection 2/3			A	B	C	D	E	H							
BH□□-FL4-05	BH□□-FL4-05-3	1/4" FITOK	1/4" FITOK	0.19 (4.8)	1.2	3.17 (80.5)	1.59 (40.4)	0.68 (17.3)	1.66 (42.2)	2.37 (60.2)	3.35 (85.1)							
BH□□-ML6-05	BH□□-ML6-05-3	6 mm FITOK	6 mm FITOK		2.5													
BH□□-ML8-05	BH□□-ML8-05-3	8 mm FITOK	8 mm FITOK		1.2	2.16 (54.9)	1.08 (27.4)											
BH□□-TS4-05	—	1/4" TS	1/4" TS			2.08 (52.8)	1.04 (26.4)											
BH□□-MTS6-05	—	6 mm MTS	6 mm MTS															
BH□□-PB4-05	—	1/4 PB, Schedule Number: 80	1/4 PB, Schedule Number: 80															
BH□□-FNS2-07	BH□□-FNS2-07-3	1/8 Female NPT	1/8 Female NPT	0.28 (7.1)	3.8	2.16 (54.9)	1.08 (27.4)	0.68 (17.3)	1.66 (42.2)	2.37 (60.2)	3.12 (79.2)							
BH□□-FRT2-07	BH□□-FRT2-07-3	1/8 Female BSPT	1/8 Female BSPT															
BH□□-FRP2-07	BH□□-FRP2-07-3	1/8 Female BSPP	1/8 Female BSPP															
BH□□-FNS4-07	BH□□-FNS4-07-3	1/4 Female NPT	1/4 Female NPT															
BH□□-FRT4-07	BH□□-FRT4-07-3	1/4 Female BSPT	1/4 Female BSPT															
BH□□-FRP4-07	BH□□-FRP4-07-3	1/4 Female BSPP	1/4 Female BSPP															
BH□□-FL6-07	BH□□-FL6-07-3	3/8" FITOK	3/8" FITOK									3.17 (80.5)	1.59 (40.4)	4.37 (111)				
BH□□-ML10-07	BH□□-ML10-07-3	10 mm FITOK	10 mm FITOK									3.20 (81.3)	1.60 (40.6)					
BH□□-TS6-07	—	3/8" TS	3/8" TS									2.16 (54.9)	1.08 (27.4)					
BH□□-PB6-07	—	3/8 PB, Schedule Number: 80	3/8 PB, Schedule Number: 80									2.08 (52.8)	1.04 (26.4)					
BH□□-FL8-10	BH□□-FL8-10-3	1/2" FITOK	1/2" FITOK									0.41 (10.4)	7.5	4.04 (103)	2.02 (51.3)	0.89 (22.6)	2.35 (59.7)	4.50 (114)
BH□□-ML12-10	BH□□-ML12-10-3	12 mm FITOK	12 mm FITOK	0.41 (10.4)														
BH□□-TS8-10	—	1/2" TS	1/2" TS	0.41 (10.4)	2.70 (68.6)	1.34 (34)												
BH□□-FNS6-13	BH□□-FNS6-13-3	3/8 Female NPT	3/8 Female NPT	0.52 (13.1)	12	2.70 (68.6)	1.35 (34.3)	0.89 (22.6)	2.35 (59.7)	4.50 (114)	4.19 (106)							
BH□□-FRT6-13	BH□□-FRT6-13-3	3/8 Female BSPT	3/8 Female BSPT															
BH□□-FRP6-13	BH□□-FRP6-13-3	3/8 Female BSPP	3/8 Female BSPP															
BH□□-FNS8-13	BH□□-FNS8-13-3	1/2 Female NPT	1/2 Female NPT															
BH□□-FRT8-13	BH□□-FRT8-13-3	1/2 Female BSPT	1/2 Female BSPT															
BH□□-FRP8-13	BH□□-FRP8-13-3	1/2 Female BSPP	1/2 Female BSPP															
BH□□-FL12-13	BH□□-FL12-13-3	3/4" FITOK	3/4" FITOK									13.6	4.04 (103)	2.02 (51.3)	0.89 (22.6)	2.35 (59.7)	4.50 (114)	4.48 (114)
BH□□-ML16-13	BH□□-ML16-13-3	16 mm FITOK	16 mm FITOK															
BH□□-ML18-13	BH□□-ML18-13-3	18 mm FITOK	18 mm FITOK										2.70 (68.6)	1.34 (34)				
BH□□-TS12-13	—	3/4" TS	3/4" TS															
BH□□-PS8-13	—	1/2 PS	1/2 PS									15						
BH□□-PB8-13	—	1/2 PB, Schedule Number: 80	1/2 PB, Schedule Number: 80	6.8	2.69 (68.3)	1.34 (34)												

B-20 Ball Valves

Basic Ordering Number		Connection Type and Size		Orifice in.(mm)	Cv	Dimensions, in. (mm)					
2-way	3-way	Connection 1	Connection 2/3			A	B	C	D	E	H
BH□□-PB12-13	—	3/4 PB, Schedule Number: 80	3/4 PB, Schedule Number: 80	0.52 (13.1)	13.6	2.69 (68.3)	1.34 (34)	0.89 (22.6)	2.35 (59.7)	4.50 (114)	—
BH□□-FNS12-22	BH□□-FNS12-22-3	3/4 Female NPT	3/4 Female NPT	0.88 (22.2)	31	3.59 (91.2)	1.8 (45.7)	1.25 (31.8)	2.94 (74.7)	6.00 (152)	5.45 (138)
BH□□-FRT12-22	BH□□-FRT12-22-3	3/4 Female BSPT	3/4 Female BSPT								
BH□□-FRP12-22	BH□□-FRP12-22-3	3/4 Female BSPP	3/4 Female BSPP								
BH□□-FNS16-22	BH□□-FNS16-22-3	1 Female NPT	1 Female NPT								
BH□□-FRT16-22	BH□□-FRT16-22-3	1 Female BSPT	1 Female BSPT								
BH□□-FRP16-22	BH□□-FRP16-22-3	1 Female BSPP	1 Female BSPP								
BH□□-FL16-22	BH□□-FL16-22-3	1" FITOK	1" FITOK								
BH□□-FL20-22	BH□□-FL20-22-3	1 1/4" FITOK	1 1/4" FITOK								
BH□□-ML25-22	BH□□-ML25-22-3	25 mm FITOK	25 mm FITOK								
BH□□-ML28-22	BH□□-ML28-22-3	28 mm FITOK	28 mm FITOK								
BH□□-TS16-22	—	1" TS	1" TS								
BH□□-MTS25-22	—	25 mm MTS	25 mm MTS								
BH□□-PS12-22	—	3/4 PS	3/4 PS								
BH□□-PS16-22	—	1 PS	1 PS								
BH□□-PB16-22	—	1 PB Schedule Number: 80	1 PB Schedule Number: 80								
BH□□-TS20-29	—	1 1/4" TS	1 1/4" TS		1.13 (28.6)	80	4.39 (112)				
BH□□-PB20-32	—	1 1/4 PB, Schedule Number: 80	1 1/4 PB, Schedule Number: 80	4.57 (116)			2.28 (57.9)				
BH□□-FNS20-32	BH□□-FNS20-32-3	1 1/4 Female NPT	1 1/4 Female NPT	1.25 (31.8)	90	4.39 (112)	2.19 (55.6)	1.53 (38.9)	4.03 (102)	9.14 (232)	6.86 (174)
BH□□-FNS24-32	BH□□-FNS24-32-3	1 1/2 Female NPT	1 1/2 Female NPT								
BH□□-TS24-32	—	1 1/2" TS	1 1/2" TS								
BH□□-PS20-32	—	1 1/4 PS	1 1/4 PS								
BH□□-PS24-32	—	1 1/2 PS	1 1/2 PS								
BH□□-PB24-32	—	1 1/2 PB, Schedule Number: 80	1 1/2 PB, Schedule Number: 80								
BH□□-FNS32-38	BH□□-FNS32-38-3	2 Female NPT	2 Female NPT	1.50 (38.1)	130	4.94 (125)	2.47 (62.5)	1.74 (44.2)	4.16 (106)	9.14 (232)	7.21 (183)
BH□□-FRT32-38	BH□□-FRT32-38-3	2 Female BSPT	2 Female BSPT								
BH□□-TS32-38	—	2" TS	2" TS								
BH□□-PS32-38	—	2 PS	2 PS								
BH□□-PB32-38	—	2 PB, Schedule Number: 80	2 PB, Schedule Number: 80								

1. FITOK means FITOK double ferrule tube fittings, TS means fractional tube socket weld, MTS means metric tube socket weld, TB means fractional tube butt weld, MTB means metric tube butt weld, PS means pipe socket weld, and PB means pipe butt weld.
2. Sizes and types listed are standard. Other sizes and types are available upon request, please contact FITOK Group or our authorized distributors.
3. Dimensions are shown with tube fitting nuts finger-tightened. All dimensions are for reference only and are subject to change. For dimensions not shown above, please contact FITOK Group or our authorized distributors.

Ordering Number Description

BHS4 - FNS8 - FRT8 - FL8 - P13G - OSHQ3L - SCEF2

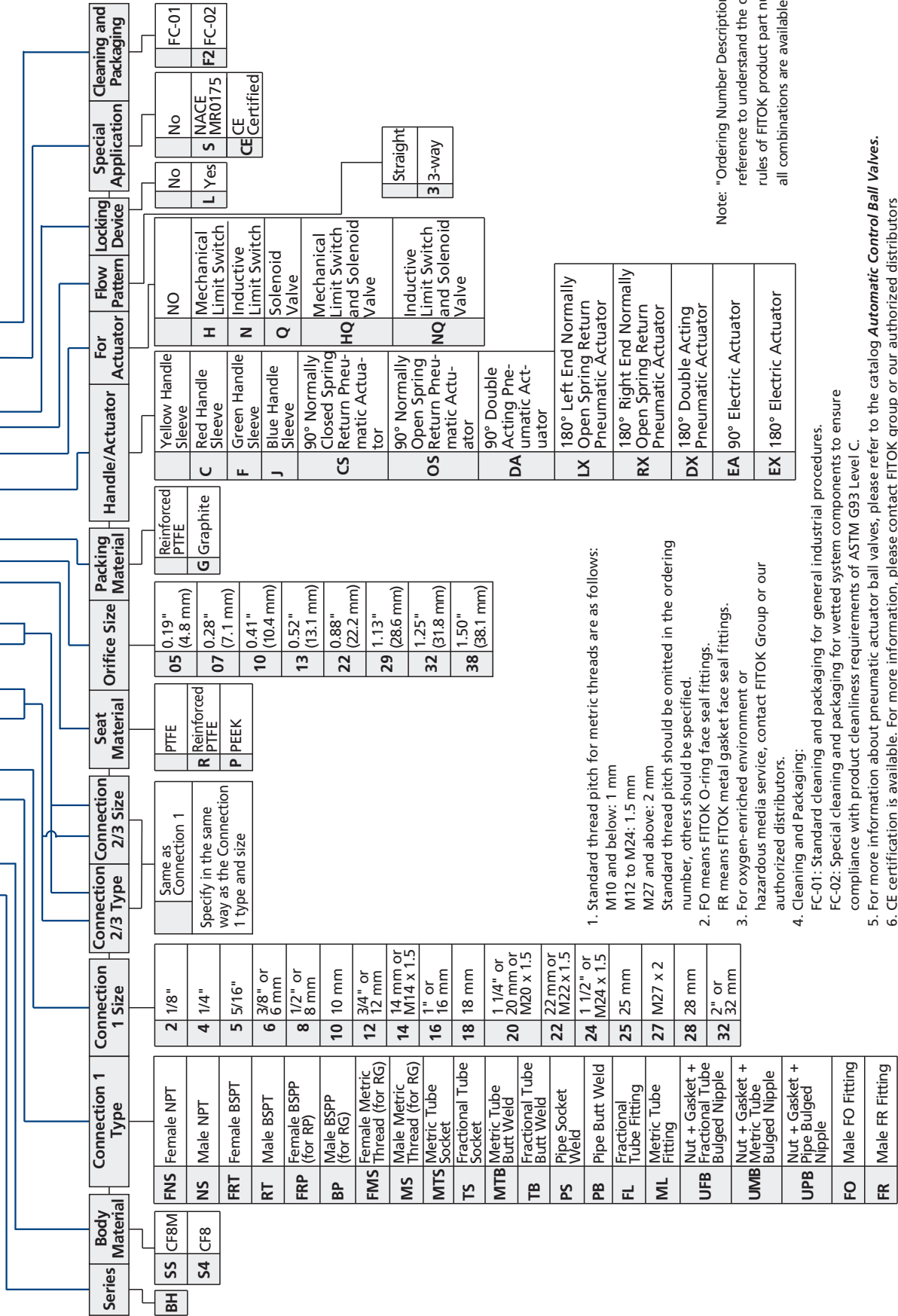

Series	Body Material	Connection 1 Type	Connection 1 Size	Connection 2/3 Type	Connection 2/3 Size	Seat Material	Orifice Size	Packing Material	Handle/Actuator	For Actuator	Flow Pattern	Locking Device	Special Application	Cleaning and Packaging
BH	SS CF8M	FNS Female NPT	2 1/8"		Same as Connection 1	PTFE	05 0.19" (4.8 mm)	Reinforced PTFE	Yellow Handle Sleeve	H	NO		No	FC-01
	S4 CF8	NS Male NPT	4 1/4"		Specify in the same way as the Connection 1 type and size	R Reinforced PTFE	07 0.28" (7.1 mm)	G Graphite	Red Handle Sleeve	C	Mechanical Limit Switch		No	F2 FC-02
		FRT Female BSPT	5 5/16"			P PEEK	10 0.41" (10.4 mm)		Green Handle Sleeve	F	Inductive Limit Switch		L Yes	
		RT Male BSPT	3/8" or 6 mm				13 0.52" (13.1 mm)		Blue Handle Sleeve	J	Solenoid Valve		S NACE MR0175	
		FRP Female BSPP (for RP)	1/2" or 8 mm				22 0.88" (22.2 mm)		90° Normally Closed Spring Return Pneumatic Actuator	CS	Mechanical Limit Switch and Solenoid Valve		CE Certified	
		BP Male BSPP (for RG)	10 10 mm				29 1.13" (28.6 mm)		90° Normally Open Spring Return Pneumatic Actuator	OS	Inductive Limit Switch and Solenoid Valve			
		FMS Female Metric Thread (for RG)	3/4" or 12 mm				32 1.25" (31.8 mm)		90° Double Acting Pneumatic Actuator	DA				
		MS Male Metric Thread (for RG)	14 14 mm or M14 x 1.5				38 1.50" (38.1 mm)		180° Left End Normally Open Spring Return Pneumatic Actuator	LX				
		MTS Metric Tube Socket	1" or 16 mm						180° Right End Normally Open Spring Return Pneumatic Actuator	RX				
		TS Fractional Tube Socket	18 18 mm						180° Double Acting Pneumatic Actuator	DX				
		MTB Metric Tube Butt Weld	1 1/4" or 20 mm or M20 x 1.5						90° Electric Actuator	EA				
		TB Fractional Tube Butt Weld	22 22 mm or M22 x 1.5						180° Electric Actuator	EX				
		PS Pipe Socket Weld	24 1 1/2" or M24 x 1.5											
		PB Pipe Butt Weld	25 25 mm											
		FL Fractional Tube Fitting	27 M27 x 2											
		ML Metric Tube Fitting	28 28 mm											
		UFB Nut + Gasket + Fractional Tube Bulged Nipple	2" or 32 mm											
		UMB Nut + Gasket + Metric Tube Bulged Nipple												
		UPB Nut + Gasket + Pipe Bulged Nipple												
		FO Male FO Fitting												
		FR Male FR Fitting												

- Standard thread pitch for metric threads are as follows:
 M10 and below: 1 mm
 M12 to M24: 1.5 mm
 M27 and above: 2 mm
 Standard thread pitch should be omitted in the ordering number, others should be specified.
- FO means FITOK O-ring face seal fittings.
 FR means FITOK metal gasket face seal fittings.
- For oxygen-enriched environment or hazardous media service, contact FITOK Group or our authorized distributors.
- Cleaning and Packaging:
 FC-01: Standard cleaning and packaging for general industrial procedures.
 FC-02: Special cleaning and packaging for wetted system components to ensure compliance with product cleanliness requirements of ASTM G93 Level C.
- For more information about pneumatic actuator ball valves, please refer to the catalog **Automatic Control Ball Valves**.
- CE certification is available. For more information, please contact FITOK group or our authorized distributors.

Note: "Ordering Number Description" is a reference to understand the combination rules of FITOK product part number. Not all combinations are available.

One-piece Instrumentation Ball Valves

BO Series

Features

- ⦿ Working pressure up to: 3000 psig (207 bar)
- ⦿ Working temperature: -65°F to 300°F (-54°C to 148°C)
- ⦿ End connections:
1/4 to 1/2 thread
1/16" to 3/4" and 3 mm to 18 mm tube fitting
- ⦿ 2-, 3-, 4-, 5-, 6- and 7-way models for on-off, switching and crossover service available
- ⦿ One-piece body and one-piece ball stem
- ⦿ No dead space
- ⦿ Top-loaded design to allow adjustment with the valve in-line
- ⦿ Thermal cycle performance improved and wear compensated by live-loaded design
- ⦿ Any reasonable connections available
- ⦿ Pneumatic and electric actuator available
- ⦿ Handle color options available
- ⦿ Full operating pressure at any port
- ⦿ Leak-tight performance testing with nitrogen or compressed air for every valve at the rated pressure to meet the requirement of no visible leak
- ⦿ The inlet can be any port except for valves with vent ports



Note:

1. To prevent seat leakage, packing adjustment may be required periodically during the service life of the valve.
2. A higher initial actuation torque may happen to the valves that have not been cycled for a period of time.
3. Before installation, instrumentation ball valves exposed to dynamic temperature conditions may lose their initial packing load. Stem packing adjustment should be required.

Standard Materials of Construction

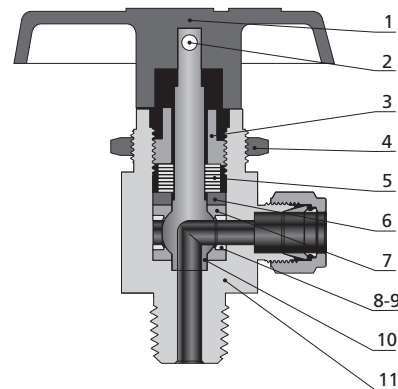
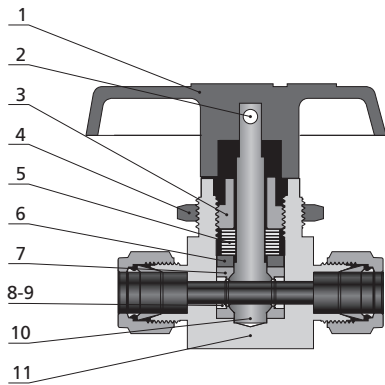

Item	Component	Valve Body Material		
		316 SS	Brass	Alloy 400
		Material Grade/ASTM Specification		
1	Handle	Nylon or Aluminium		
2	Set Screw	Galvanized carbon steel		
3	Packing Bolt	316 SS/A479	Brass C36000/B16	Alloy 400/B164
4	Panel Nut	316 SS/A479	Brass C36000/B16	316 SS/A479
5	Disc Spring	S17700/A693		
6	Gland	316 SS/A479	316 SS/A479	Alloy 400/B164
7	<i>Packing Seat</i>	<i>PTFE/D1710 or UHMWPE/D4020 or PFA/D3307</i>		
8	<i>Support Ring</i>	316 SS/A479	316 SS/A479	Alloy 400/B164
9	<i>Support Disc</i>			
10	<i>Ball Stem</i>	316 SS/A479	Brass C36000/B16	Alloy 400/B164
11	<i>Body</i>	316 SS/A182	Brass C37700/B16	Alloy 400/B164
<i>Wetted Lubricant</i>		<i>Fluorinated-based and silicone-based</i>		
Non-wetted Lubricant		Molybdenum disulfide with hydrocarbon binder coat		

Note: Wetted components are listed in italics.
For other materials, please contact FITOK Group or our authorized distributors.

On-Off (2-way) Valves

Standard Flow Path

Straight Pattern



Angle Pattern



Pressure vs. Temperature

Straight Pattern and Angle Pattern

PTFE Packing Seat

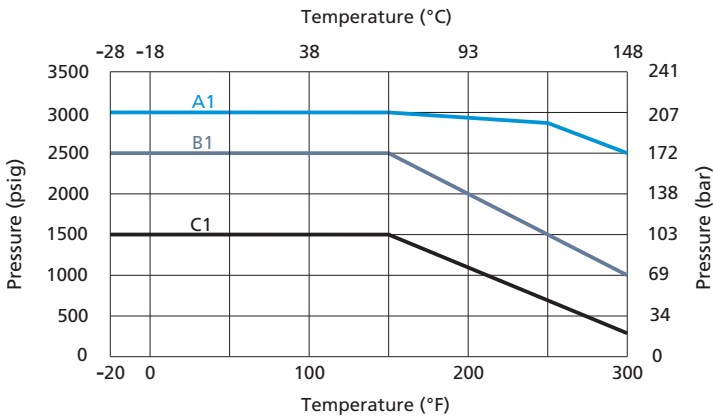

A1: Straight Pattern Valves (orifice 0.19")

B1: Straight Pattern Valves (orifice 0.05" & 0.06" & 0.09" & 0.13" & 0.28" & 0.41")

Angle Pattern Valves (orifice 0.05" & 0.06" & 0.09" & 0.13" & 0.19")

C1: Angle Pattern Valves (orifice 0.28" & 0.41")

PFA, UHMWPE Packing Seat

The working temperature of UHMWPE packing seat should not be higher than 150°F (65°C).

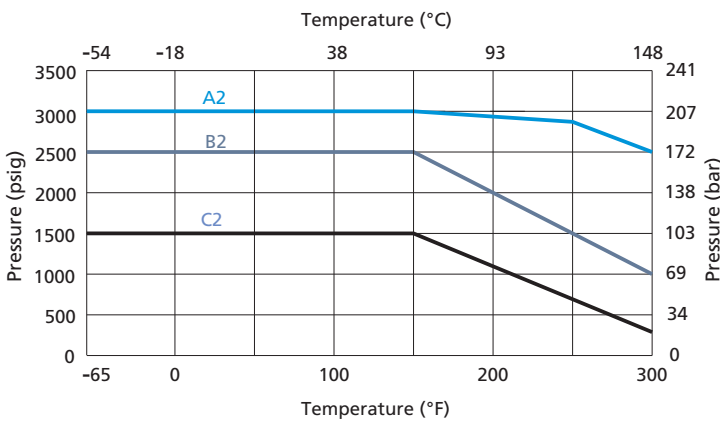

A2: Straight Pattern Valves (orifice 0.19")

B2: Straight Pattern Valves (orifice 0.05" & 0.06" & 0.09" & 0.13" & 0.28" & 0.41")

Angle Pattern Valves (orifice 0.05" & 0.06" & 0.09" & 0.13" & 0.19")

C2: Angle Valves (orifice 0.28" & 0.41")

Dimensions

Straight Pattern

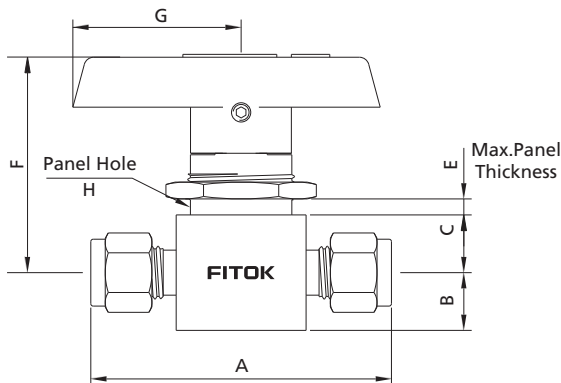

Angle Pattern

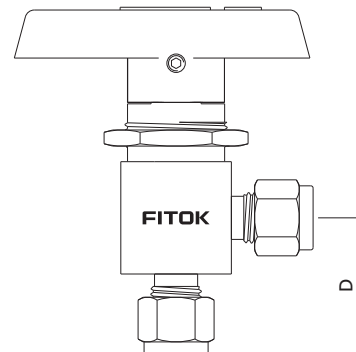

Basic Ordering Number	Connection Type and Size	Orifice in. (mm)	Cv		Dimensions, in. (mm)								
			Straight	Angle	A	B	C	D	E	F	G	H	
BO□□-FL1-00	1/16" FITOK	0.05 (1.3)	0.10	—	1.68 (42.7)				—				
BO□□-FL2-02	1/8" FITOK	0.09 (2.4)	0.20	0.15	2.01 (51.1)	0.28 (7.1)	0.34 (8.6)	0.97 (24.6)	0.25 (6.4)	1.43 (36.2)	1.10 (28)	19/32 (15.1)	
BO□□-FL4-03	1/4" FITOK	0.13 (3.2)	0.60	0.35	2.21 (56.1)			1.07 (27.2)					
BO□□-FL4-05		0.19 (4.8)	1.40	0.90	2.39 (60.7)	0.38 (9.7)	0.44 (11.2)	1.17 (29.7)	0.19 (4.8)	1.64 (41.7)	1.57 (39.9)	25/32 (19.8)	
BO□□-FL6-05	3/8" FITOK		1.50		2.58 (65.5)			1.29 (32.8)					
BO□□-FL6-07		0.28 (7.1)	6.00	2.00	3.05 (77.5)	0.56 (14.2)	0.56 (14.2)	1.43 (36.3)	0.35 (9)	2.19 (55.5)	2.05 (52)	1 1/8 (28.6)	
BO□□-FL8-10	1/2" FITOK	0.41 (10.3)	6.40	3.80	3.92 (99.6)	0.69 (17.5)	0.69 (17.5)	1.74 (44.2)	0.49 (12.5)	2.67 (67.7)	3.13 (79.6)	1 1/2 (38.1)	
BO□□-FL12-10	3/4" FITOK		12.00	4.60									
BO□□-ML3-02	3 mm FITOK	0.09 (2.4)	0.20	0.15	2.01 (51.1)	0.28 (7.1)	0.34 (8.6)	0.97 (24.6)	0.25 (6.4)	1.43 (36.2)	1.10 (28)	19/32 (15.1)	
BO□□-ML6-03	6 mm FITOK	0.13 (3.2)	0.60	0.35	2.21 (56.1)			1.07 (27.2)					
BO□□-ML6-05		0.19 (4.8)	1.40	0.90	2.39 (60.7)	0.38 (9.7)	0.44 (11.2)	1.17 (29.7)	0.19 (4.8)	1.64 (41.7)	1.57 (39.9)	25/32 (19.8)	
BO□□-ML8-05	8 mm FITOK		1.50		2.46 (62.5)			1.20 (30.5)					
BO□□-ML10-07	10 mm FITOK	0.28 (7.1)	6.00	2.00	3.07 (78.0)	0.56 (14.2)	0.56 (14.2)	1.43 (36.3)	0.35 (9)	2.19 (55.5)	2.05 (52)	1 1/8 (28.6)	
BO□□-ML12-10	12 mm FITOK	0.41 (10.3)	12.00	4.60	3.92 (99.6)	0.69 (17.5)	0.69 (17.5)	1.74 (44.2)	0.49 (12.5)	2.67 (67.7)	3.13 (79.6)	1 1/2 (38.1)	
BO□□-FNS2-03	1/8 Female NPT	0.13 (3.2)	0.50	0.30	1.63 (41.4)	0.28 (7.1)	0.34 (8.6)	0.81 (20.6)	0.25 (6.4)	1.43 (36.2)	1.10 (28)	19/32 (15.1)	
BO□□-FNS2-05		0.19 (4.8)	1.20	0.70	2.00 (50.8)	0.38 (9.7)	0.44 (11.2)	1.00 (25.4)	0.19 (4.8)	1.64 (41.7)	1.57 (39.9)	25/32 (19.8)	
BO□□-FNS4-05	1/4 Female NPT		0.90	0.75	2.06 (52.3)			1.03 (26.2)					
BO□□-FNS4-07		0.28 (7.1)	3.00	1.70	2.50 (63.5)	0.56 (14.2)	0.56 (14.2)	1.25 (31.8)	0.35 (9)	2.19 (55.5)	2.05 (52)	1 1/8 (28.6)	
BO□□-FNS6-07	3/8 Female NPT		2.60	1.50									
BO□□-FNS8-10	1/2 Female NPT	0.41 (10.3)	6.30	3.50	3.12 (79.2)	0.69 (17.5)	0.69 (17.5)	1.56 (39.6)	0.49 (12.5)	2.67 (67.7)	3.13 (79.6)	1 1/2 (38.1)	
BO□□-NS4-05	1/4 Male NPT	0.19 (4.8)	1.20	0.75	2.00 (50.8)	0.38 (9.7)	0.44 (11.2)	1.03 (26.2)	0.19 (4.8)	1.64 (41.7)	1.57 (39.9)	25/32 (19.8)	
BO□□-FRT4-05	1/4 Female BSPT		0.90		2.06 (52.3)								
BO□□-FRT6-07	3/8 Female BSPT	0.28 (7.1)	2.60	—	2.50 (63.5)	0.56 (14.2)	0.56 (14.2)	—	0.35 (9)	2.19 (55.5)	2.05 (52)	1 1/8 (28.6)	
BO□□-FRT8-10	1/2 Female BSPT	0.41 (10.3)	6.30	—	3.12 (79.2)	0.69 (17.5)	0.69 (17.5)	—	0.49 (12.5)	2.67 (67.7)	3.13 (79.6)	1 1/2 (38.1)	
BO□□-FO4-03	1/4 Male FO	0.13 (3.2)	0.60	0.35	1.75 (44.4)		0.34 (8.6)	0.94 (23.9)	0.25 (6.4)	1.43 (36.2)	1.10 (28)	19/32 (15.1)	
BO□□-FO4-05		0.19 (4.8)	2.40	0.90	1.88 (47.8)	0.38 (9.7)	0.44 (11.2)		0.19 (4.8)	1.64 (41.7)	1.57 (39.9)	25/32 (19.8)	
BO□□-FR4-03	1/4 Male FR	0.13 (3.2)	0.60	0.35	2.13 (54.1)		0.34 (8.6)	1.09 (27.7)	0.25 (6.4)	1.43 (36.2)	1.10 (28)	19/32 (15.1)	
BO□□-FR4-05		0.19 (4.8)	2.40	0.90			0.44 (11.2)		0.19 (4.8)	1.64 (41.7)	1.57 (39.9)	25/32 (19.8)	
BO□□-FR8-07	1/2 Male FR	0.28 (7.1)	6.00	—	2.88 (73.2)	0.56 (14.2)			0.35 (9)	2.19 (55.5)	2.05 (52)	1 1/8 (28.6)	
BO□□-FR8-10		0.41 (10.3)	12.00	—	3.12 (79.2)	0.69 (17.5)			0.49 (12.5)	2.67 (67.7)	3.13 (79.6)	1 1/2 (38.1)	

Switching (3-, 4-, 5-, 6- and 7-way) Valves

Standard Flow Path

3-way Valves

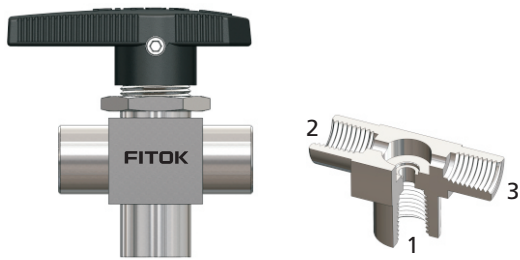

4-way Valves

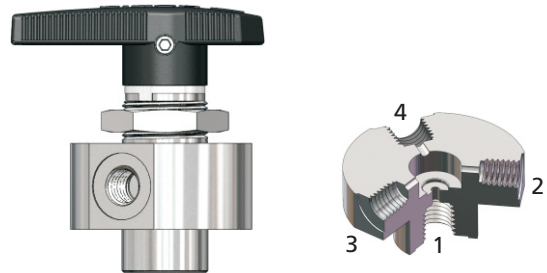

3L Flow Path

This type of valve can connect one side port to the bottom port or shut off 3 ports. Switch between 0°, 90° and 180° positions with 180° rotation handle.

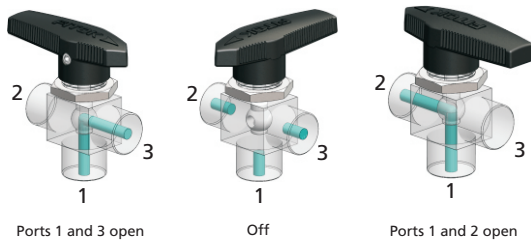

4L Flow Path

This type of valve can connect one side port to the bottom port, and shut off other 2 side ports at the same time. Switching can be done in 120° increments with 360° rotation handle.



5-way Valves

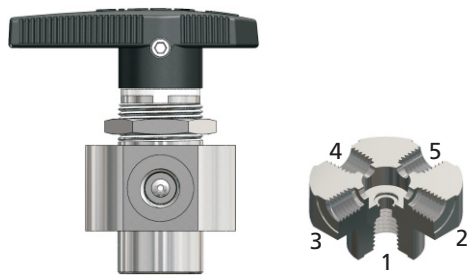

5L Flow Path

This type of valve can connect one side port to the bottom port, and shut off other 3 side ports at the same time. Switching can be done in 90° increments with 360° rotation handle.

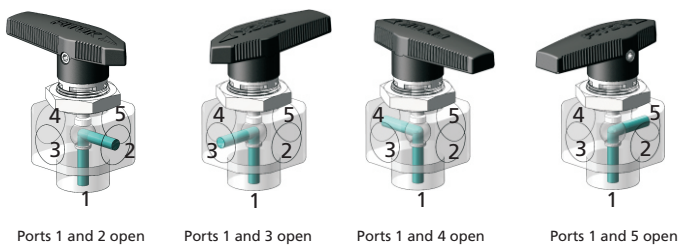

6-way Valves

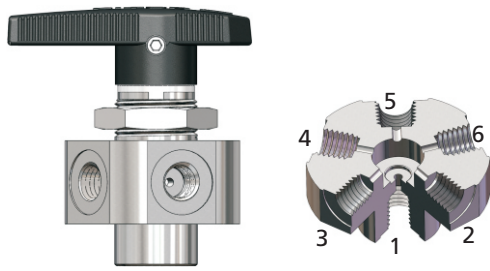

6L Flow Path

This type of valve can connect one side port to the bottom port, and shut off other 4 side ports at the same time. Switching can be done in 72° increments with 360° rotation handle.

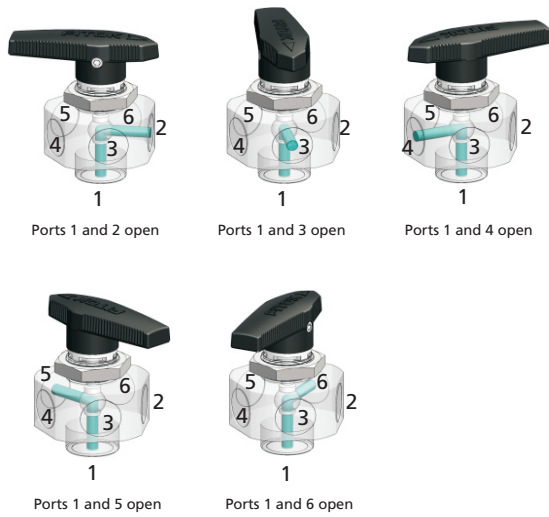

7-way Valves

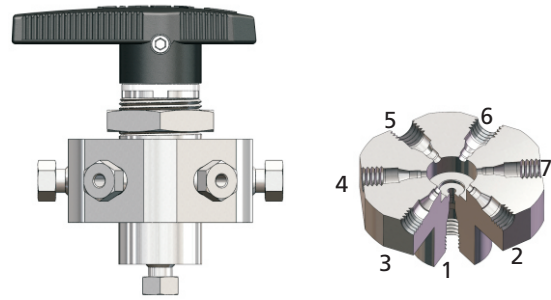

7L Flow Path

This type of valve can connect one side port to the bottom port, and shut off other 5 side ports at the same time. Switching can be done in 60° increments with 360° rotation handle.

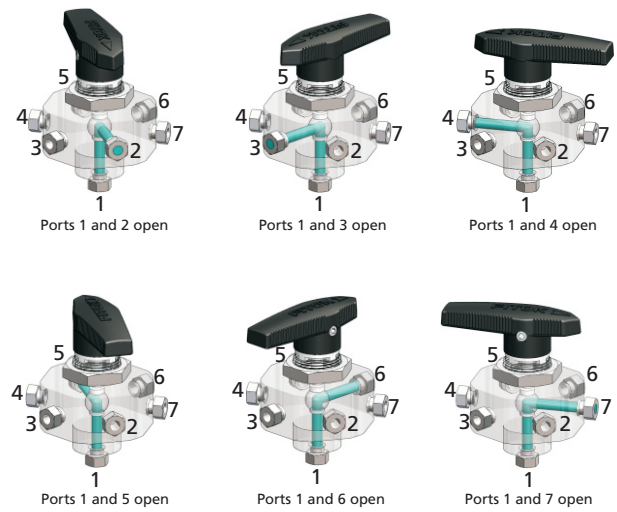

Pressure vs. Temperature

Switching Valves

PTFE Packing Seat

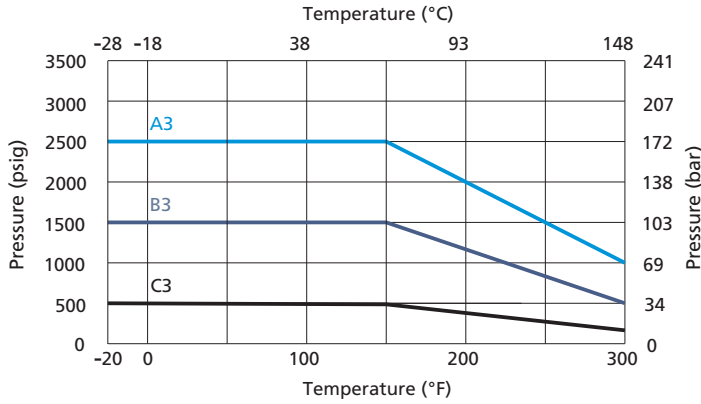

A3: 3-way (orifice 0.05" & 0.06" & 0.09" & 0.13" & 0.19")
4-way / 5-way (orifice 0.06")

B3: 3-way (orifice 0.28" & 0.41")
4-way / 5-way (orifice 0.41")

C3: 6-way / 7-way (orifice 0.05" & 0.06")

PFA, UHMWPE Packing Seat

The working temperature of UHMWPE packing seat should not be higher than 150°F (65°C).

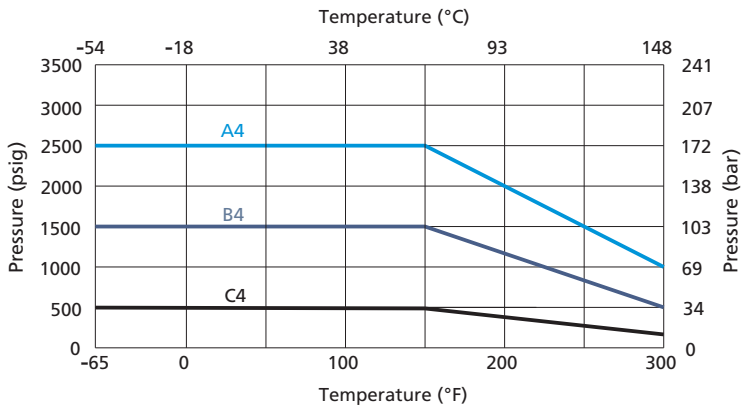

A4: 3-way (orifice 0.05" & 0.06" & 0.09" & 0.13" & 0.19")
4-way / 5-way (orifice 0.06")

B4: 3-way (orifice 0.28" & 0.41")
4-way / 5-way (orifice 0.41")

C4: 6-way / 7-way (orifice 0.05" & 0.06")

Dimensions

3-way Valves

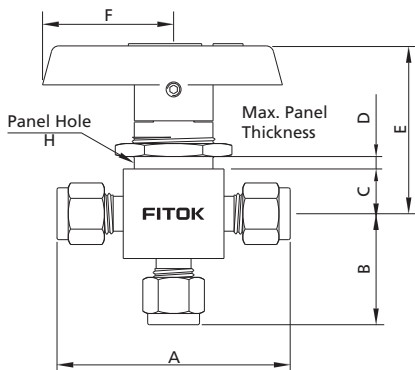

4-and 5-way Valves

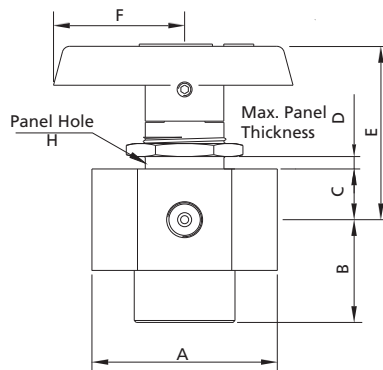

6-and 7-way Valves

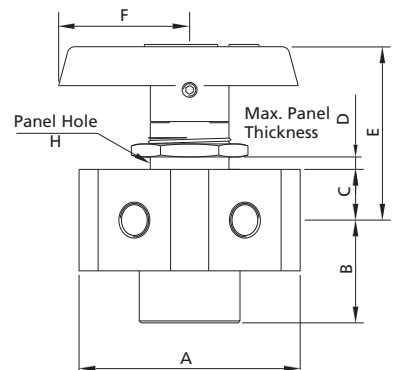

Basic Ordering Number	Connection Type and Size	Orifice in. (mm)	Cv	Dimensions, in. (mm)						
				A	B	C	D	E	F	H
3-way Valves										
BO□□-FL1-00-3L	1/16" FITOK	0.05 (1.3)	0.08	1.68 (42.7)	0.81 (20.6)					
BO□□-FL2-02-3L	1/8" FITOK	0.09 (2.4)	0.15	2.01 (51.1)	0.97 (24.6)	0.34 (8.6)	0.25 (6.4)	1.43 (36.2)	1.10 (28)	19/32 (15.1)
BO□□-FL4-03-3L	1/4" FITOK	0.13 (3.2)	0.35	2.21 (56.1)	1.07 (27.2)					
BO□□-FL4-05-3L		0.19 (4.8)	0.90	2.39 (60.7)	1.17 (29.7)	0.44 (11.2)	0.19 (4.8)	1.64 (41.7)	1.57 (39.9)	25/32 (19.8)
BO□□-FL6-07-3L	3/8" FITOK	0.28 (7.1)	2.00	2.89 (73.4)	1.43 (36.3)	0.56 (14.2)	0.35 (9)	2.19 (55.5)	2.05 (52)	11/8 (28.6)
BO□□-FL8-10-3L	1/2" FITOK	0.41 (10.3)	4.60	3.48 (88.4)	1.74 (44.2)	0.69 (17.5)	0.49 (12.5)	2.67 (67.7)	3.13 (79.6)	11/2 (38.1)
BO□□-FL12-10-3L	3/4" FITOK		4.90							
BO□□-ML3-02-3L	3 mm FITOK	0.09 (2.4)	0.15	2.01 (51.1)	0.97 (24.6)	0.34 (8.6)	0.25 (6.4)	1.43 (36.2)	1.10 (28)	19/32 (15.1)
BO□□-ML6-03-3L	6 mm FITOK	0.13 (3.2)	0.35	2.21 (56.1)	1.07 (27.2)					
BO□□-ML6-05-3L		8 mm FITOK	0.19 (4.8)	0.90	2.39 (60.7)	1.17 (29.7)	0.44 (11.2)	0.19 (4.8)	1.64 (41.7)	1.57 (39.9)
BO□□-ML8-05-3L	0.80			2.46 (62.5)	1.20 (30.5)					
BO□□-ML10-07-3L	10 mm FITOK	0.28 (7.1)	2.00	2.89 (73.4)	1.43 (36.3)	0.56 (14.2)	0.35 (9)	2.19 (55.5)	2.05 (52)	1 1/8 (28.6)
BO□□-ML12-10-3L	12 mm FITOK	0.41 (10.3)	4.60	3.48 (88.4)	1.74 (44.2)	0.69 (17.5)	0.49 (12.5)	2.67 (67.7)	3.13 (79.6)	1 1/2 (38.1)
BO□□-FNS2-03-3L	1/8 Female NPT	0.13 (3.2)	0.30	1.63 (41.4)	0.81 (20.6)	0.34 (8.6)	0.25 (6.4)	1.43 (36.2)	1.10 (28)	19/32 (15.1)
BO□□-FNS4-05-3L	1/4 Female NPT	0.19 (4.8)	0.75	2.06 (52.3)	1.03 (26.2)	0.44 (11.2)	0.19 (4.8)	1.64 (41.7)	1.57 (39.9)	25/32 (19.8)
BO□□-FNS4-07-3L		0.28 (7.1)	1.70	2.5 (63.5)	1.18 (30)	0.56 (14.2)	0.35 (9)	2.19 (55.5)	2.05 (52)	1 1/8 (28.6)
BO□□-FNS6-07-3L	3/8 Female NPT		1.50							
BO□□-FNS8-10-3L	1/2 Female NPT	0.41 (10.3)	3.50	3.13 (79.5)	1.56 (39.6)	0.69 (17.5)	0.49 (12.5)	2.67 (67.7)	3.13 (79.6)	1 1/2 (38.1)
BO□□-FRT4-05-3L	1/4 Female BSPT	0.19 (4.8)	0.75	2.06 (52.3)	1.03 (26.2)	0.44 (11.2)	0.19 (4.8)	1.64 (41.7)	1.57 (39.9)	25/32 (19.8)
BO□□-FRT6-07-3L	3/8 Female BSPT	0.28 (7.1)	1.50	2.5 (63.5)	1.18 (30)	0.56 (14.2)	0.35 (9)	2.19 (55.5)	2.05 (52)	1 1/8 (28.6)
BO□□-FRT8-10-3L	1/2 Female BSPT	0.41 (10.3)	3.50	3.13 (79.5)	1.56 (39.6)	0.69 (17.5)	0.49 (12.5)	2.67 (67.7)	3.13 (79.6)	1 1/2 (38.1)
4 - & 5-way Valves										
BO□□-FL2-01-4L	1/8" Female FITOK Tube Fitting	0.06 (1.6)	0.07	2.36 (60)	1.32 (33.5)	0.44 (11.2)	0.20 (5.2)	1.76 (44.6)	1.57 (39.9)	29/32 (23.1)
BO□□-FL2-01-5L				1.85 (47)	0.88 (22.4)					
BO□□-FNS2-01-4L	1/8 Female NPT	0.06 (1.6)	0.07	1.55 (39.4)						
BO□□-FNS2-01-5L										
BO□□-FNS8-10-4L	1/2 Female NPT	0.41 (10.3)	3.50	3.13 (79.5)	1.56 (39.6)	0.69 (17.5)	0.41 (10.5)	2.67 (70.2)	2.63 (66.7)	1 1/2 (38.1)
BO□□-FNS8-10-5L										
6 - & 7-way Valves										
BO□□-FL1-00-6L	1/16" Female FITOK Tube Fitting	0.05 (1.3)	0.05	2.64 (67)	1.32 (33.5)	0.44 (11.2)	0.28 (7)	1.76 (44.6)	1.57 (39.9)	29/32 (23.1)
BO□□-FL1-00-7L										
BO□□-FL2-01-6L	1/8" Female FITOK Tube Fitting	0.06 (1.6)	0.07	2.26 (57.6)	0.97 (24.7)					
BO□□-FL2-01-7L										

Crossover (4-, 6-way) Valves

Standard Flow Path

4-way Valves

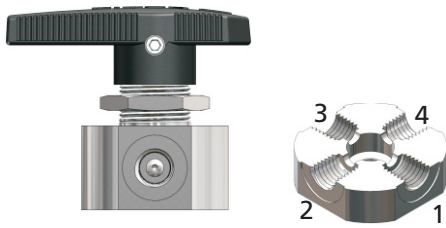

6-way Valves

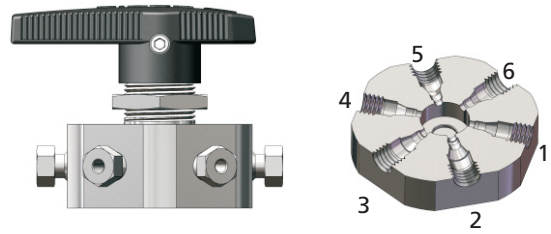

4C Flow Path

This type of valve can connect two groups of adjacent ports at the same time. Switch between 0° and 90° positions with 90° rotation handle.

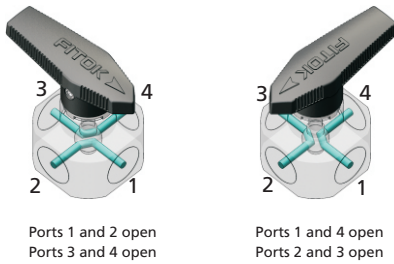

Ports 1 and 2 open
Ports 3 and 4 open

Ports 1 and 4 open
Ports 2 and 3 open

6C Flow Path

This type of valve can connect three groups of adjacent ports at the same time. Switch between 0° and 60° positions with 60° rotation handle.

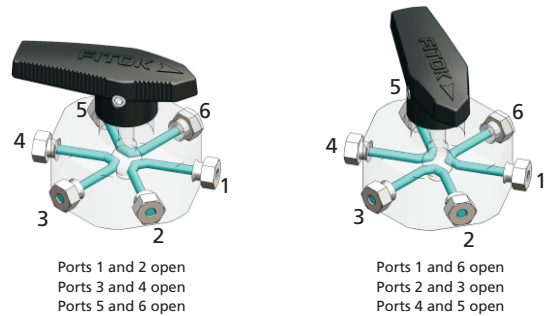

Ports 1 and 2 open
Ports 3 and 4 open
Ports 5 and 6 open

Ports 1 and 6 open
Ports 2 and 3 open
Ports 4 and 5 open

Pressure vs. Temperature

Crossover Valves

PTFE Packing Seat

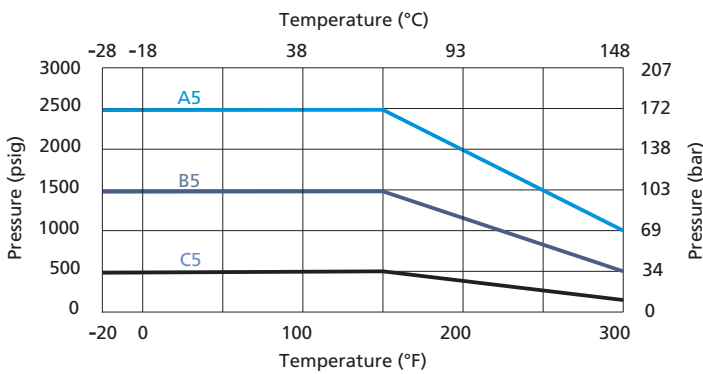

A5: 4-way (orifice 0.06")

B5: 4-way (orifice 0.41")

C5: 6-way (orifice 0.05" & 0.06")

PFA, UHMWPE Packing Seat

The working temperature of UHMWPE packing seat should not be higher than 150°F (65°C).

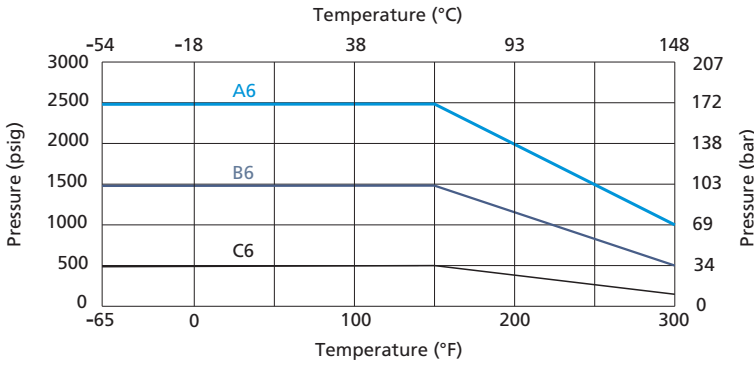

- A6: 4-way (orifice 0.06")
- B6: 6-way (orifice 0.41")
- C6: 6-way (orifice 0.05" & 0.06")

Dimensions

4-way Valves

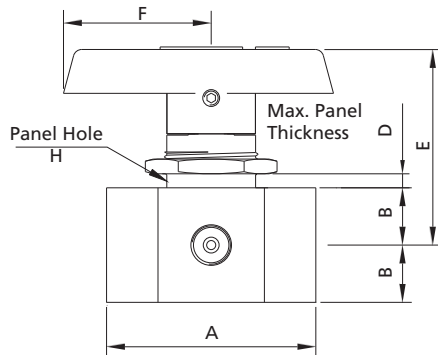

6-way Valves

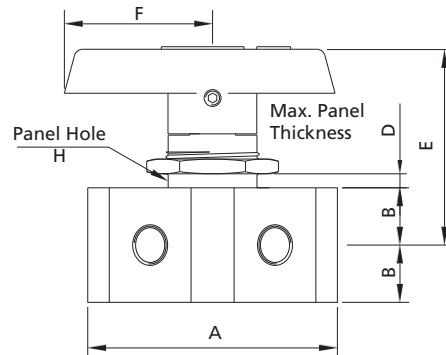

Basic Ordering Number	Connection Type and Size	Orifice in. (mm)	Cv	Dimensions, in. (mm)						
				A	B	D	E	F	H	
4-way Valve										
BO□□-FL1-00-4C	1/16" Female FITOK Tube Fitting	0.05 (1.3)	0.06	1.95 (49.6)						
BO□□-FL2-01-4C	1/8" Female FITOK Tube Fitting	0.06 (1.6)	0.08	2.61 (66.3)	0.44 (11.2)	0.19 (4.8)	1.64 (41.7)	1.57 (39.9)	25/32 (19.8)	
BO□□-FNS2-01-4C	1/8 Female NPT			1.55 (39.4)						
BO□□-FNS8-07-4C	1/2 Female NPT	0.28 (7.1)	1.60	3.13 (79.5)	0.69 (17.5)	0.48 (12.2)	2.67 (67.7)	3.13 (79.6)	1 1/2 (38.1)	
6-way Valve										
BO□□-FL1-00-6C	1/16" Female FITOK Tube Fitting	0.05 (1.3)	0.06	1.95 (49.5)	0.44 (11.2)	0.19 (4.8)	1.68 (42.7)	1.53 (38.9)	29/32 (23.1)	
BO□□-FL2-01-6C	1/8" Female FITOK Tube Fitting	0.06 (1.6)	0.08	2.59 (65.8)						

Note: Connection type for ball valves in 4L, 5L, 6L, 7L, 4C, 6C, 4H, 4HL, 4V, 5HL, 5H and 5LV flow path is female FITOK tube fitting, which can not be used directly with standard FT and MT connections. Please contact FITOK Group or authorized distributors for use with standard FT and MT connections.

1. FITOK means FITOK double ferrule tube fittings.
 2. Sizes and types listed are standard. Other sizes and types are available upon request, please contact FITOK Group or our authorized distributors.
 3. Dimensions are shown with tube fitting nuts finger-tightened. All dimensions are for reference only and are subject to change.
- For dimensions not shown above, please contact FITOK Group or our authorized distributors.

Special Flow Path

3-way Valves

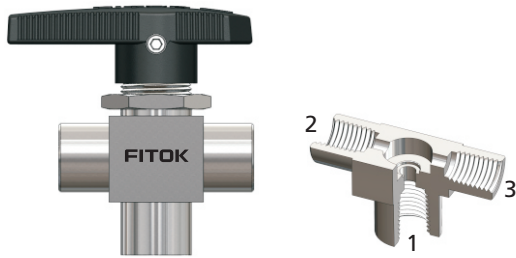

3HL Flow Path

This type of valve can connect one side port to the bottom port, or connect two side ports to the bottom port. Switching can be done in 90° increments with 180° rotation handle.

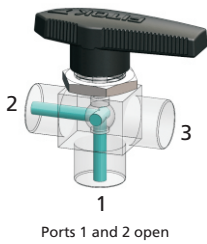
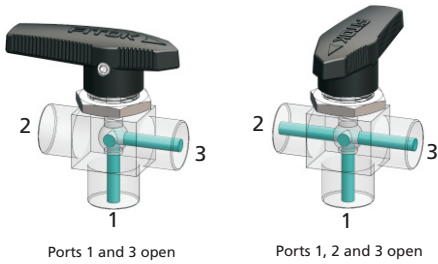

Note: For Temperature VS. Pressure curves and dimensions of 3-way valves, see Switching (3-way) Valves above. For Temperature VS. Pressure curves and dimensions of 4-way valves, see Crossover (4-way) Valves above.

4-way Valves

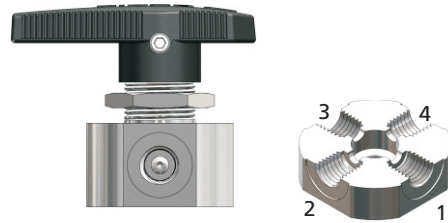

4H Flow Path

This type of valve can connect two opposite ports. Switch between 0° and 90° positions with 90° rotation handle.

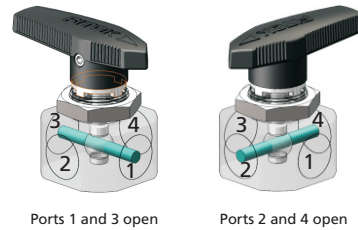

4HL Flow Path

This type of valve can connect three adjacent ports and shut off other ports. Switching can be done in 90° increments with 360° rotation handle.

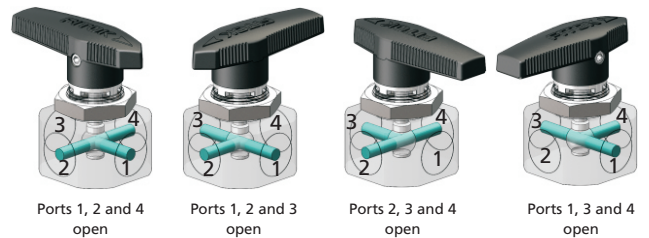

4V Flow Path

This type of valve can connect two adjacent ports and shut off other ports. Switching can be done in 90° increments with 360° rotation handle.

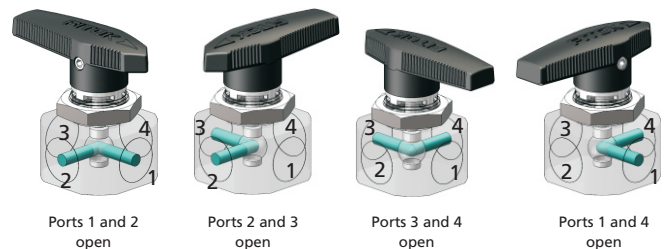

5-way Valves

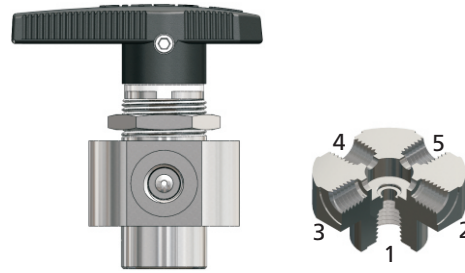

5HL Flow Path

This type of valve can connect three side ports to the bottom port, and shut off the fourth side port at the same time. Switching can be done in 90° increments with 360° rotation handle.

5H Flow Path

This type of valve can connect the bottom port to port 2 and port 4, or connect the bottom port to port 3 and port 5. Switch between 0° and 90° positions with 90° rotation handle.

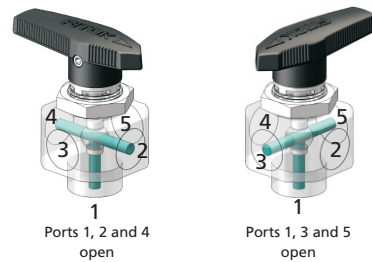
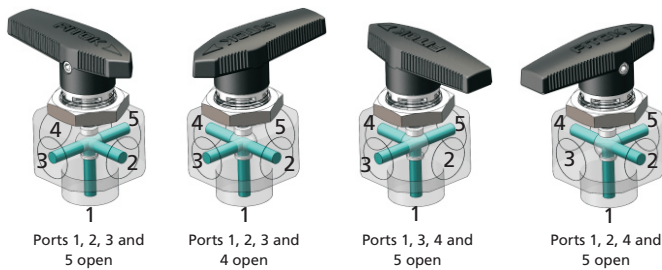

5LV Flow Path

This type of valve can connect two adjacent ports to the bottom port, and shut off other two side ports at the same time. Switching can be done in 90° increments with 360° rotation handle.

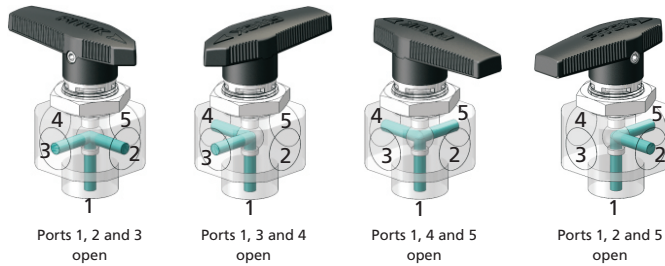

Note: For Temperature vs. Pressure curve and dimensions of 5-way valves, see Switching (5-way) Valves above.

Vent Port Options

Vented Valves

The maximum working pressure for vented valves is 500 psig (34.4 bar).

Straight-pattern Valves

A vent hole in the side of the valve body makes the downstream port vent to atmosphere when the valve is closed.

Angle-pattern and 3-way Valves

A vent hole in the side of the valve body makes the bottom port vent to atmosphere when the valve is closed.

Welded Vent Port Connections

A FITOK tube fitting or a tube stub welded to the vent port is available for stainless steel vented valves.

Bottom Screw Panel Mounting Options

Mounting Dimensions

The bottom screw panel mounting options are not available on angle-pattern valves, 3-way valves, 6-way valves and 7-way valves.

2-way

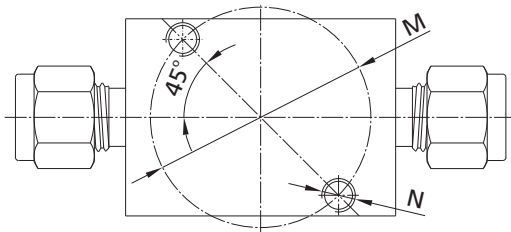

4-way

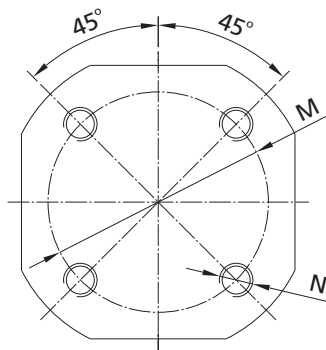

5-way

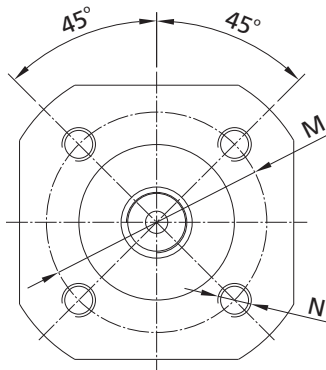

	Orifice in. (mm)	Dimensions, in. (mm)	
		M	N
2-way	0.05~0.13 (1.3~3.2)	0.63 (15.88)	M2.5 x 0.45 deep 0.24" (6)
	0.19 (4.8)	0.88 (22.23)	M3 x 0.5 deep 0.24" (6)
	0.28 (7.1)	1.25 (31.75)	M5 x 0.8 deep 0.24" (6)
4-way	0.41 (10.3)	1.63 (41.28)	M5 x 0.8 deep 0.24" (6)
	0.05~0.06 (1.3~1.6)	1.25 (31.75)	M5 x 0.8 deep 0.24" (6)
5-way	0.28 (7.1)	2.00 (50.8)	M5 x 0.8 deep 0.24" (6)
	0.05~0.06 (1.3~1.6)	1.25 (31.75)	M5 x 0.8 deep 0.24" (6)
5-way	0.41 (10.3)	2.00 (50.8)	M5 x 0.8 deep 0.24" (6)
	0.05~0.06 (1.3~1.6)	1.25 (31.75)	M5 x 0.8 deep 0.24" (6)

Ordering Number Description

BOSS - ML6 - FL4 - ML8 - H05 - OSHQ3L - B - FL4 - SCEF2

Series	Body Material	Connection 1 Type	Connection 1 Size	Connection 2 to 7 Type	Connection 2 to 7 Size	Seat Material	Orifice Size	Handle/Actuator	For Actuator	Flow Pattern	Panel Installation	Vent Port	Special Application	Cleaning and Packaging
BO	SS 316 SS S4 304 SS S1 321 SS 6L 316L SS B Brass M Alloy 400	FNS Female NPT NS Male NPT FRT Female BSPT RT Male BSPT FMS Female Metric Thread (for RG) MS Male Metric Thread (for RG) FRP Female BSPP (for RP) FL Fractional Tube Fitting ML Metric Tube Fitting FO Male FO Fitting FR Male FR Fitting	1 1/16" 2 1/8" 3 3 mm 4 1/4" 6 3/8" or 6 mm 8 1/2" or 8 mm 10 10 mm 12 3/4" or 12 mm 14 14 mm 16 16 mm 18 18 mm	Same as connection 1 Specified in the same way as the connection 1 type and size	00 0.05" (1.3 mm) 01 0.06" (1.6 mm) 02 0.09" (2.4 mm) 03 0.13" (3.2 mm) 05 0.19" (4.8 mm) 07 0.28" (7.1 mm) 10 0.41" (10.3 mm)	C Black Nylon F Red Nylon J Green Nylon U Blue Nylon Aluminium CS 90° Normally Closed Spring Return Pneumatic Actuator OS 90° Normally Open Spring Return Pneumatic Actuator DA 90° Double Acting Pneumatic Actuator LX 180° Left End Normally Open Spring Return Pneumatic Actuator RX 180° Right End Normally Open Spring Return Pneumatic Actuator DX 180° Double Acting Pneumatic Actuator EA 90° Electric Actuator EX 180° Electric Actuator	NO H Mechanical Limit Switch N Inductive Limit Switch Q Solenoid Valve HQ and Solenoid Valve NQ Inductive Limit Switch and Solenoid Valve	A Straight 3L Angle 3HL 3-way 4L 4-way 4C 4-way 4H 4-way 4HL 4-way 4V 4-way 5L 5-way 5H 5-way 5HL 5-way 5LV 5-way 6L 6-way 6C 6-way 7L 7-way	No vent port FL2 1/8" tube fitting FL4 1/4" tube fitting FL6 3/8" tube fitting ML3 3 mm tube fitting ML6 6 mm tube fitting ML8 8 mm tube fitting Panel nut Bottom screw B	NO NACE S MR0175 CE Certified	FC-01 F2 FC-02			

Note: "Ordering Number Description" is a reference to understand the combination rules of FITOK product part number. Not all combinations are available.

- For oxygen-enriched environment or hazardous media service, contact FITOK Group or our authorized distributors.
- Cleaning and Packaging:
FC-01: Standard cleaning and packaging for general industrial procedures.
FC-02: Special cleaning and packaging for wetted system components to ensure compliance with product cleanliness requirement of ASTM G93 Level C.
- For more information about pneumatic actuator ball valves, please refer to the catalog **Automatic Control Ball Valves**.
- CE certification is available. For more information, please contact FITOK group or our authorized distributors

Bar Stock Ball Valves

BP Series

Features

- ⦿ Working pressure up to: 10000 psig (690 bar)
- ⦿ Working temperature: -40°F to 450°F (-40°C to 232°C)
- ⦿ Bidirectional flow for 2-way valves
- ⦿ Seat wear compensation by free floating ball
- ⦿ Variety of end connections
- ⦿ Blowout proof stem with self-sealing function
- ⦿ Handle color options available
- ⦿ Optional pneumatic and electric actuator
- ⦿ Leak-tight performance testing with nitrogen or compressed air for every valve at the rated pressure (not higher than 6000 psig) to meet the requirement of no visible leak
- ⦿ Restricted flow path for BP series: only port 1 as inlet, port 2 and port 3 as outlet



Pressure vs. Temperature

2-way Valves

Orifice code: 10

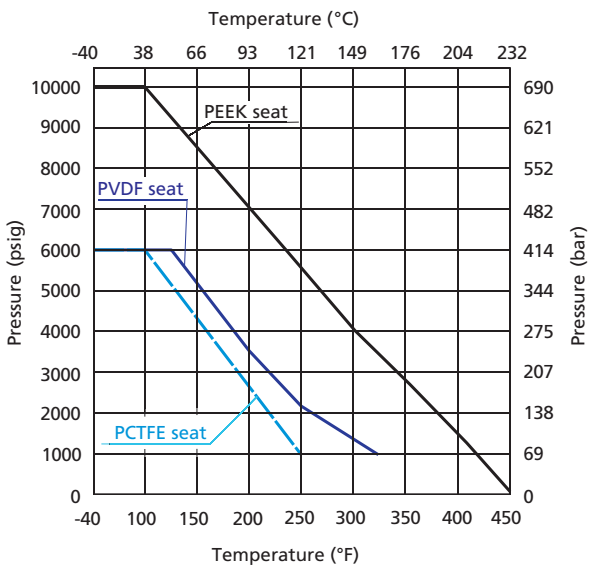

Orifice code: 13 and 19

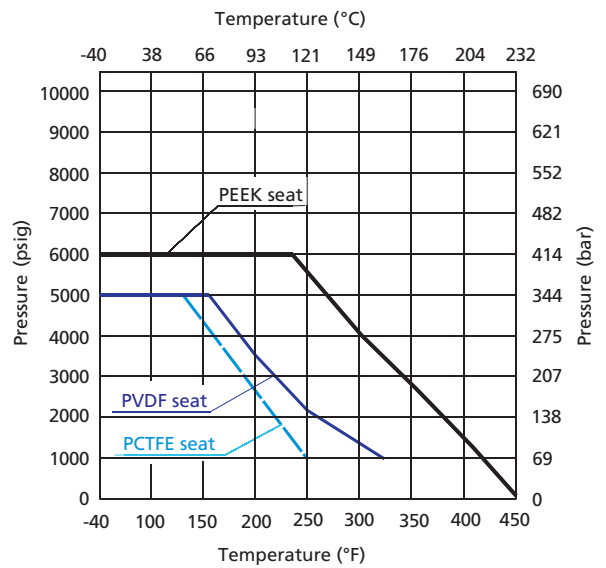

3-way Valves

Orifice code: 10

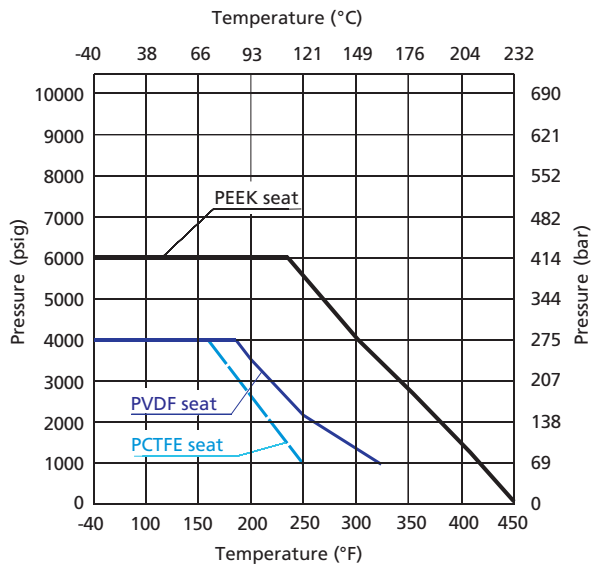

Orifice code: 13 and 19

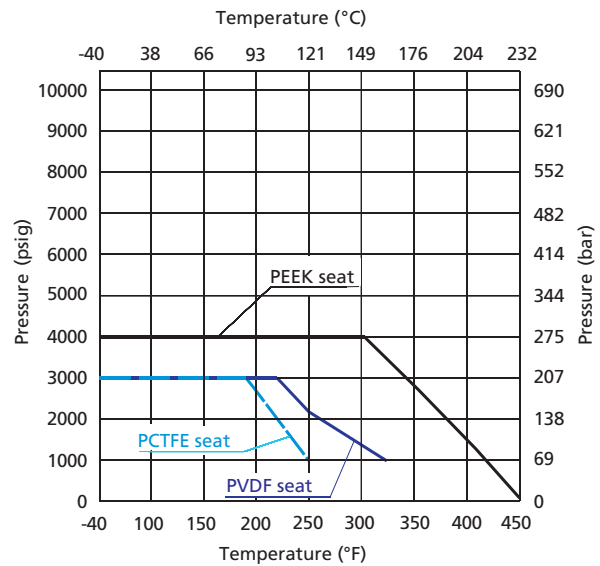

- Note: 1. Graphs are with 316SS body. For information of body in other materials, please contact FITOK Group or our authorized distributors.
 2. The working pressure of valves is restricted by materials of the valve body and seat, as well as end connections. When choosing a valve for your applications, please refer to the above Temperature vs. Pressure Curves and the pressure rating in the dimension table. The minimum value shall be the pressure rating of the valve.

Standard Materials of Construction

2-way Valves

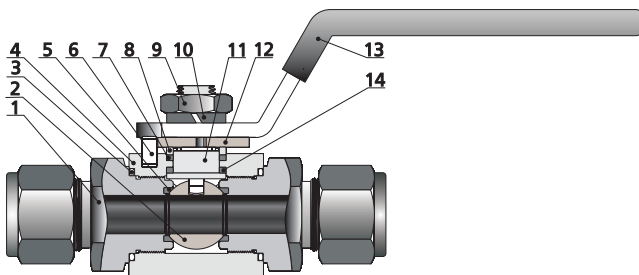

3-way Valves

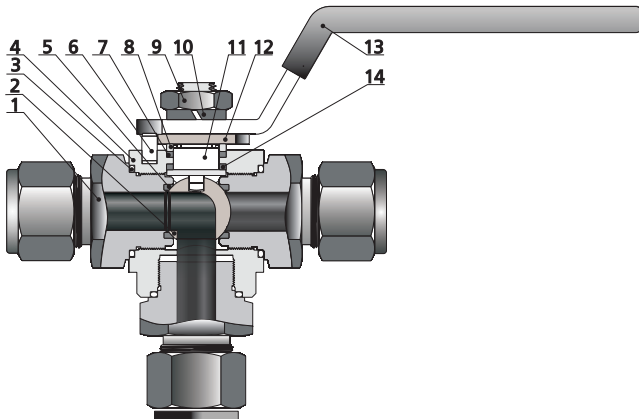

Item	Component	Body Material
		316 SS
1	<i>End Connection</i>	<i>316 SS/A479</i>
2	<i>Ball</i>	<i>316 SS/A479</i>
3	<i>O-ring</i>	<i>Fluorocarbon FKM</i>
4	<i>Body</i>	<i>316 SS/A479</i>
5	<i>Seat</i>	<i>PVDF or PCTFE or PEEK</i>
6	<i>Stop Pin</i>	SS
7	<i>Stem Packing</i>	<i>PTFE/D1710</i>
8	<i>Stem Washer</i>	316 SS/A479
9	<i>Stem Nut</i> ①	SS
10	<i>Spring Washer</i>	SS
11	<i>Stem</i>	<i>316 SS/A479</i>
12	<i>Stop Block</i>	304 SS/A240
13	<i>Handle</i>	SS with vinyl cover
14	<i>Lower Packing</i> ②	PEEK

Note: Wetted components are listed in italics.
 For other materials, please contact FITOK Group or our authorized distributors.

- ① Ball valves with orifice code 13 or 19 have 2 stem nuts.
- ② Lower packing material of ball valves with orifice code 19 is PTFE.

Ball Valves
Plug Valves

Dimensions

2-way Valves

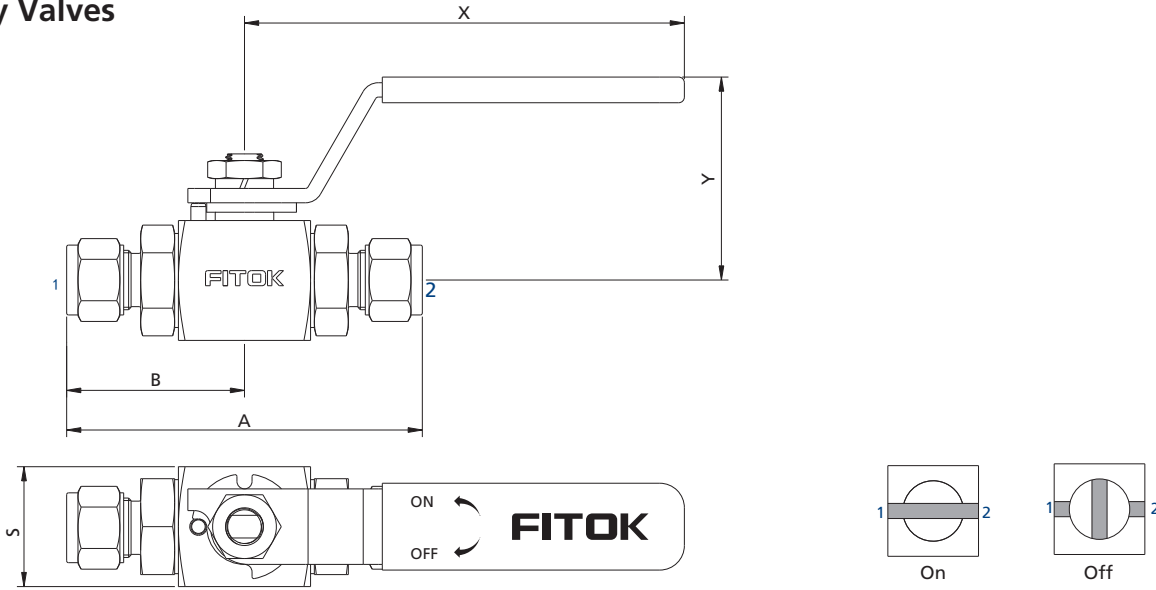

Ball Valves
Plug Valves

Basic Ordering Number	Connection Type and Size	Pressure Rating of End Connections @ 100°F (38°C), psig (bar)	Orifice in. (mm)	Cv	Dimensions, in. (mm)									
					A	B	X	Y	S					
BP□□-ML6-10	6 mm FITOK	10000 (690)	0.19(4.8)	1.2	3.54 (90.0)	1.77 (45.0)	4.57 (116.0)	2.10 (53.4)	1.30 (32.0)					
BP□□-ML8-10	8 mm FITOK	7500 (517)	0.25(6.4)	2.3	3.60 (91.6)	1.80 (45.8)								
BP□□-ML10-10	10 mm FITOK	8400 (579)	0.28(7.1)	3.7	3.70 (94.0)	1.85 (47.0)								
BP□□-ML12-10	12 mm FITOK	6800 (469)	0.39 (10.0)	7.5	3.94 (100.0)	1.97 (50.0)								
BP□□-ML14-10	14 mm FITOK	6200 (427)			3.92 (99.6)	1.96 (49.8)								
BP□□-FL4-10	1/4" FITOK	10000 (690)	0.19(4.8)	1.2	3.56 (90.4)	1.78 (45.2)				4.57 (116.0)	2.10 (53.4)	1.30 (32.0)		
BP□□-FL6-10	3/8" FITOK	6500 (448)	0.28(7.1)	3.7	3.72 (94.6)	1.86 (47.3)								
BP□□-FL8-10	1/2" FITOK	6700 (462)	0.39 (10.0)	7.5	3.92 (99.6)	1.96 (49.8)								
BP□□-FNS4-10	1/4 Female NPT	10000 (690)			3.03 (77.0)	1.52 (38.5)								
BP□□-FNS6-10	3/8 Female NPT	10000 (690)			2.80 (71.0)	1.40 (35.5)								
BP□□-FNS8-10	1/2 Female NPT	10000 (690)			3.27 (83.0)	1.63 (41.5)								
BP□□-NS4-10	1/4 Male NPT	10000 (690)	0.28(7.1)	3.7	3.36 (85.4)	1.68 (42.7)	4.57 (116.0)	2.10 (53.4)	1.30 (32.0)					
BP□□-NS6-10	3/8 Male NPT	10000 (690)	0.39 (10.0)	7.5	3.75 (95.2)	1.88 (47.6)								
BP□□-NS8-10	1/2 Male NPT	10000 (690)			3.36 (85.4)	1.68 (42.7)								
BP□□-ML16-13	16 mm FITOK	5800 (400)			0.50 (12.7)	10.0				4.42 (112.2)	2.21 (56.1)	5.59 (142.0)	2.54 (64.4)	1.50 (38.0)
BP□□-ML18-13	18 mm FITOK	5400 (372)	4.12 (104.6)	2.06 (52.3)										
BP□□-ML20-13	20 mm FITOK	5500 (379)	4.43 (112.6)	2.22 (56.3)										
BP□□-ML22-13	22 mm FITOK	4900 (338)	4.29 (109.0)	2.15 (54.5)										
BP□□-FL10-13	5/8" FITOK	6000 (414)	4.36 (110.6)	2.18 (55.3)										
BP□□-FL12-13	3/4" FITOK	5800 (400)	3.54 (90.0)	1.77 (45.0)										
BP□□-FNS8-13	1/2 Female NPT	6000 (414)	4.09 (104.0)	2.05 (52.0)										
BP□□-FNS12-13	3/4 Female NPT	6000 (414)	4.14 (105.2)	2.07 (52.6)										
BP□□-NS12-13	3/4 Male NPT	6000 (414)	0.71 (18.0)	30.0			4.87 (123.8)	2.43 (61.9)	6.46 (164.0)	2.72 (69.0)	1.96 (50.0)			
BP□□-ML20-19	20 mm FITOK	5500 (379)					5.11 (129.8)	2.66 (64.9)						
BP□□-ML22-19	22 mm FITOK	4900 (338)			4.59 (116.6)	2.29 (58.3)								
BP□□-ML25-19	25 mm FITOK	4600 (317)			5.11 (129.8)	2.66 (64.9)								
BP□□-FL12-19	3/4" FITOK	5800 (400)			3.81 (96.8)	1.91 (48.4)								
BP□□-FL16-19	1" FITOK	4700 (324)			4.26 (108.2)	2.13 (54.1)								
BP□□-FNS12-19	3/4 Female NPT	6000 (414)			4.91 (124.8)	2.45 (62.4)								
BP□□-FNS16-19	1 Female NPT	6000 (414)												
BP□□-NS16-19	1 Male NPT	6000 (414)												

3-way Valves

Vertical Pattern

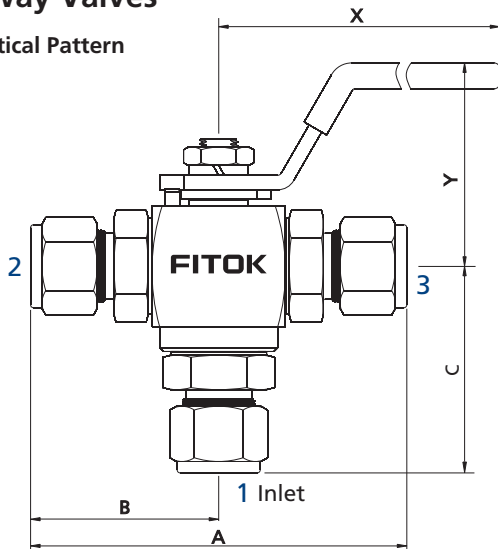

Port 1 as inlet
180° rotation handle

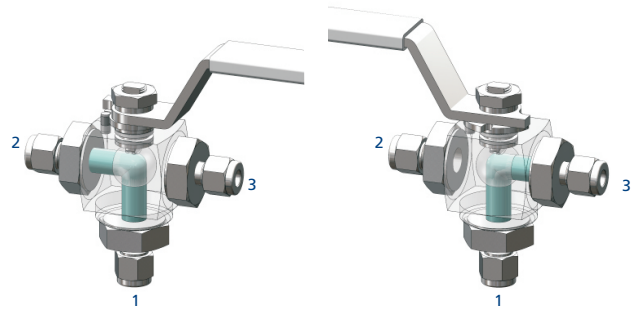

Port 1 to port 2

Port 1 to port 3

Horizontal Pattern

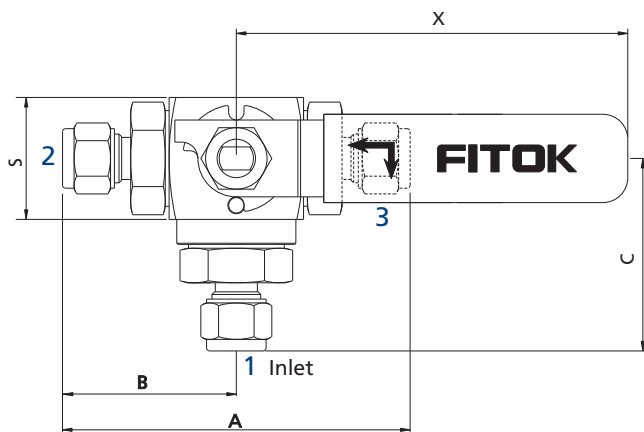

Port 1 as inlet
90° rotation handle

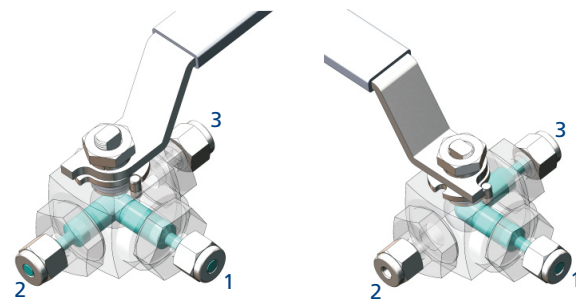

Port 1 to port 2

Port 1 to port 3

Ball Valves
Plug Valves

Basic Ordering Number	Connection Type and Size	Pressure Rating of End Connections @ 100 °F (38 °C), psig (bar)	Orifice in. (mm)	Dimensions, in. (mm)						
				A	B	C	X	Y	S	
BP□□-ML6-10-3□	6 mm FITOK	10000 (690)	0.19 (4.8)	3.54 (90.0)	1.77 (45.0)	2.00 (51.0)	4.57 (116.0)	2.10 (53.4)	1.30 (32.0)	
BP□□-ML8-10-3□	8 mm FITOK	7500 (517)	0.25 (6.4)	3.60 (91.6)	1.80 (45.8)	2.02 (51.3)				
BP□□-ML10-10-3□	10 mm FITOK	8400 (579)	0.28 (7.1)	3.70 (94.0)	1.85 (47.0)	2.07 (52.5)				
BP□□-ML12-10-3□	12 mm FITOK	6800 (469)	0.39 (10.0)	3.94 (100.0)	1.97 (50.0)	2.18 (55.5)				
BP□□-ML14-10-3□	14 mm FITOK	6200 (427)		3.94 (100.0)	1.97 (50.0)	2.18 (55.5)				
BP□□-FL4-10-3□	1/4" FITOK	10000 (690)	0.19 (4.8)	3.56 (90.4)	1.78 (45.2)	1.95 (49.5)				
BP□□-FL6-10-3□	3/8" FITOK	6500 (448)	0.28 (7.1)	3.72 (94.6)	1.86 (47.3)	2.16 (54.8)				
BP□□-FL8-10-3□	1/2" FITOK	6700 (462)	0.39 (10.0)	3.92 (99.6)	1.96 (49.8)	2.13 (54.0)				
BP□□-FNS4-10-3□	1/4 Female NPT	10000 (690)		3.03 (77.0)	1.52 (38.5)	1.44 (36.5)				
BP□□-FNS6-10-3□	3/8 Female NPT	10000 (690)		2.80 (71.0)	1.40 (35.5)	1.57 (40.0)				
BP□□-FNS8-10-3□	1/2 Female NPT	10000 (690)		3.27 (83.0)	1.63 (41.5)	1.83 (46.4)				
BP□□-NS4-10-3□	1/4 Male NPT	10000 (690)		0.28 (7.1)	3.36 (85.4)	1.68 (42.7)				1.90 (48.2)
BP□□-NS6-10-3□	3/8 Male NPT	10000 (690)			3.36 (85.4)	1.68 (42.7)				1.90 (48.2)
BP□□-NS8-10-3□	1/2 Male NPT	10000 (690)	3.75 (95.2)		1.88 (47.6)	2.09 (53.1)				

Basic Ordering Number	Connection Type and Size	Pressure Rating of End Connections @ 100°F (38°C), psig (bar)	Orifice in. (mm)	Dimensions, in. (mm)					
	Connection 1/2/3			316 SS	A	B	C	X	Y
BP□□-ML16-13-3□	16 mm FITOK	5800 (400)	0.50 (12.7)	4.42 (112.2)	2.21 (56.1)	2.60 (66.1)	5.59 (142.0)	2.54 (64.4)	1.50 (38.0)
BP□□-ML18-13-3□	18 mm FITOK	5400 (372)		4.12 (104.6)	2.06 (52.3)	2.45 (62.3)			
BP□□-ML20-13-3□	20 mm FITOK	5500 (379)		4.43 (112.6)	2.22 (56.3)	2.61 (66.3)			
BP□□-ML22-13-3□	22 mm FITOK	4900 (338)		4.29 (109.0)	2.15 (54.5)	2.54 (64.5)			
BP□□-FL10-13-3□	5/8" FITOK	6000 (414)		4.36 (110.6)	2.18 (55.3)	2.57 (65.3)			
BP□□-FL12-13-3□	3/4" FITOK	5800 (400)		3.54 (90.0)	1.77 (45.0)	2.02 (51.2)			
BP□□-FNS8-13-3□	1/2 Female NPT	6000 (414)		4.09 (104.0)	2.05 (52.0)	2.44 (62.0)			
BP□□-FNS12-13-3□	3/4 Female NPT	6000 (414)		4.14 (105.2)	2.07 (52.6)	2.46 (62.6)			
BP□□-NS12-13-3□	3/4 Male NPT	6000 (414)							
BP□□-ML20-19-3□	20 mm FITOK	5500 (379)	0.71 (18.0)	4.87 (123.8)	2.43 (61.9)	2.89 (73.4)	6.46 (164.0)	2.72 (69.0)	1.96 (50.0)
BP□□-ML22-19-3□	22 mm FITOK	4900 (338)		5.11 (129.8)	2.66 (64.9)	3.00 (76.2)			
BP□□-ML25-19-3□	25 mm FITOK	4600 (317)		4.86 (123.4)	2.43 (61.7)	3.02 (76.7)			
BP□□-FL12-19-3□	3/4" FITOK	5800 (400)		5.11 (129.8)	2.66 (64.9)	2.85 (72.4)			
BP□□-FL16-19-3□	1" FITOK	4700 (324)		3.82 (97.0)	1.91 (48.5)	2.22 (56.5)			
BP□□-FNS12-19-3□	3/4 Female NPT	6000 (414)		4.26 (108.2)	2.13 (54.1)	2.72 (69.1)			
BP□□-FNS16-19-3□	1 Female NPT	6000 (414)		4.54 (115.2)	2.27 (57.6)	2.72 (69.1)			
BP□□-NS12-19-3□	3/4 Male NPT	6000 (414)		4.91 (124.8)	2.45 (62.4)	2.90 (73.9)			
BP□□-NS16-19-3□	1 Male NPT	6000 (414)							

1. FITOK means FITOK double ferrule tube fittings.
2. Sizes and types listed are standard. Other sizes and types are available upon request, please contact FITOK Group or our authorized distributors.
3. Dimensions are shown with tube fitting nuts finger-tightened. All dimensions are for reference only and are subject to change.
For dimensions not shown above, please contact FITOK Group or our authorized distributors.

Panel Mounting Options

Dimension for Panel Mounting

Orifice in. (mm)	in. (mm)			
	L1	L2	T1	T2
0.39 (10.0)	1.02 (26.0)	1.02 (26.0)	M4 × 0.7P deep 0.19 (5.0)	1.18 (30.0)
0.50 (12.7)	1.18 (30.0)	1.18 (30.0)	M5 × 0.8P deep 0.19 (5.0)	1.18 (30.0)
0.71 (18.0)	1.37 (35.0)	1.57 (40.0)	M5 × 0.8P deep 0.19 (5.0)	1.50 (38.0)

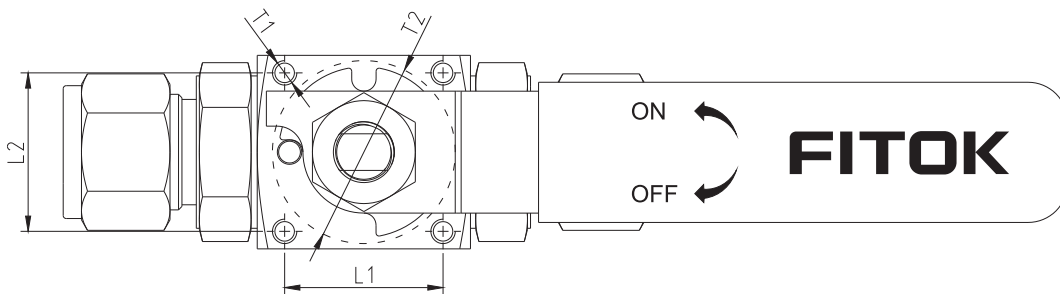

Ordering Number Description

BPSS - ML20 - FL12 - FNS8 - P13 - OSHQ3ML - SCEF2

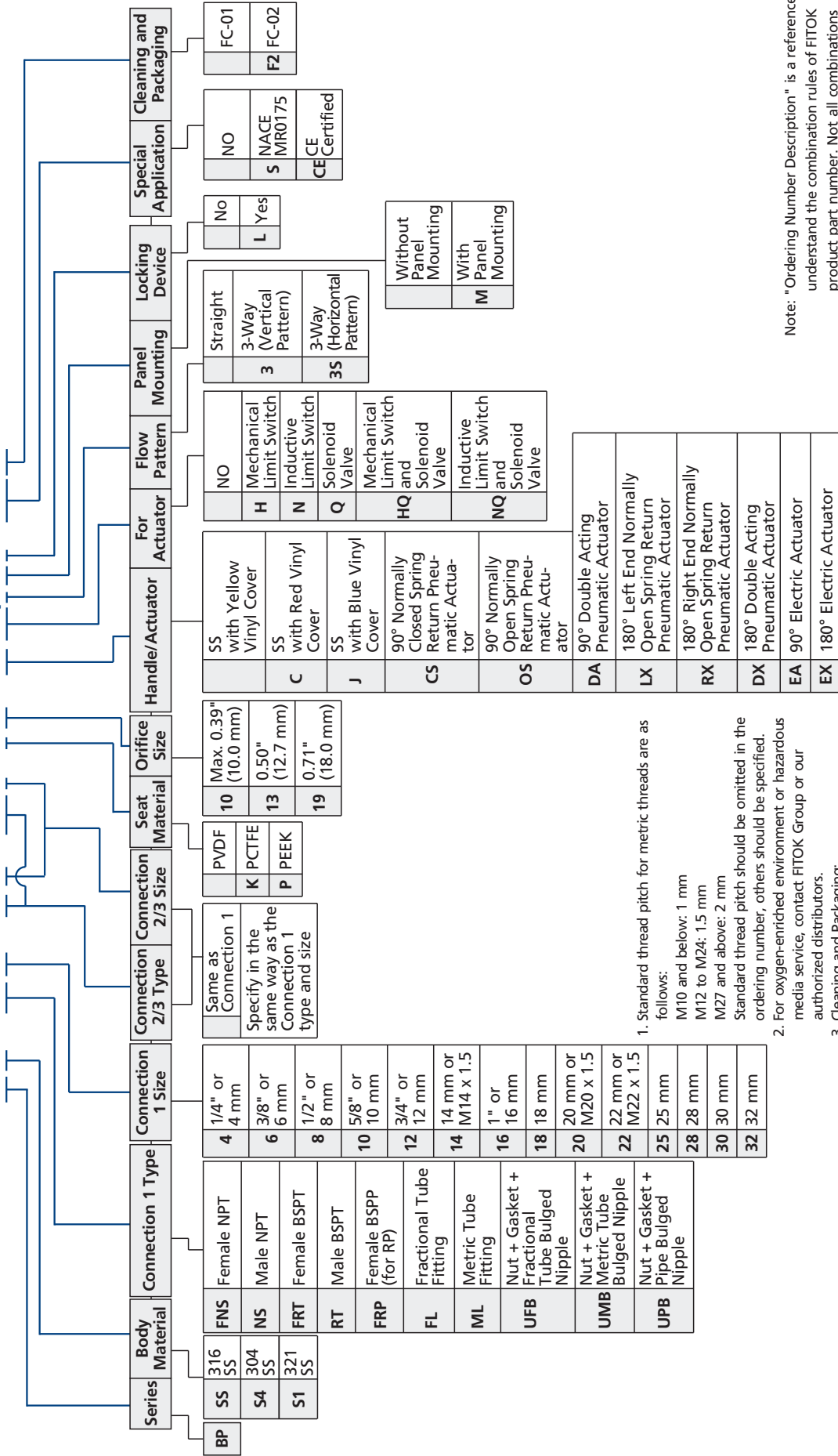

Series	Body Material	Connection 1 Type	Connection 1 Size	Connection 2/3 Type	Connection 2/3 Size	Seat Material	Orifice Size	Handle/Actuator	For Actuator	Flow Pattern	Panel Mounting	Locking Device	Special Application	Cleaning and Packaging										
BP	SS	FNS	Female NPT	4	1/4" or 4 mm	K	PCTFE	SS with Yellow Vinyl Cover	H	NO	Straight	No	NO	FC-01										
		NS	Male NPT	6	3/8" or 6 mm										P	PEEK	C	SS with Red Vinyl Cover	N	Inductive Limit Switch	3	L	NACE MR0175	F2
		FRT	Female BSPT	8	1/2" or 8 mm																			
RT	Male BSPT	10	5/8" or 10 mm	CS	90° Normally Closed Spring Return Pneumatic Actuator	HQ	Mechanical Limit Switch and Solenoid Valve	M	Without Panel Mounting	With Panel Mounting	FC-02													
FRP	Female BSPP (for Rp)	12	3/4" or 12 mm									OS	90° Normally Open Spring Return Pneumatic Actuator	NQ	Inductive Limit Switch and Solenoid Valve	EA	90° Electric Actuator	EX	180° Electric Actuator					
FL	Fractional Tube Fitting	14	14 mm or M14 x 1.5	DA	90° Double Acting Pneumatic Actuator	DA	Double Acting Pneumatic Actuator	LX	180° Left End Normally Open Spring Return Pneumatic Actuator	RX	180° Right End Normally Open Spring Return Pneumatic Actuator									DX	180° Double Acting Pneumatic Actuator			
ML	Metric Tube Fitting	16	1" or 16 mm									UPB	Nut + Gasket + Fractional Tube Bulged Nipple	UPB	Nut + Gasket + Metric Tube Bulged Nipple	EA	90° Electric Actuator	EX	180° Electric Actuator					
UFB	Nut + Gasket + Fractional Tube Bulged Nipple	18	18 mm	UPB	Nut + Gasket + Metric Tube Bulged Nipple	UPB	Nut + Gasket + Metric Tube Bulged Nipple	EA	90° Electric Actuator	EX	180° Electric Actuator													
UMB	Nut + Gasket + Metric Tube Bulged Nipple	20	20 mm or M20 x 1.5									UPB	Nut + Gasket + Metric Tube Bulged Nipple	UPB	Nut + Gasket + Metric Tube Bulged Nipple	EA	90° Electric Actuator	EX	180° Electric Actuator					
UPB	Nut + Gasket + Pipe Bulged Nipple	22	22 mm or M22 x 1.5	UPB	Nut + Gasket + Metric Tube Bulged Nipple	UPB	Nut + Gasket + Metric Tube Bulged Nipple	EA	90° Electric Actuator	EX	180° Electric Actuator													
		25	25 mm									UPB	Nut + Gasket + Metric Tube Bulged Nipple	UPB	Nut + Gasket + Metric Tube Bulged Nipple	EA	90° Electric Actuator	EX	180° Electric Actuator					
		28	28 mm	UPB	Nut + Gasket + Metric Tube Bulged Nipple	UPB	Nut + Gasket + Metric Tube Bulged Nipple	EA	90° Electric Actuator	EX	180° Electric Actuator													
		30	30 mm									UPB	Nut + Gasket + Metric Tube Bulged Nipple	UPB	Nut + Gasket + Metric Tube Bulged Nipple	EA	90° Electric Actuator	EX	180° Electric Actuator					
		32	32 mm	UPB	Nut + Gasket + Metric Tube Bulged Nipple	UPB	Nut + Gasket + Metric Tube Bulged Nipple	EA	90° Electric Actuator	EX	180° Electric Actuator													

- Standard thread pitch for metric threads are as follows:
 M10 and below: 1 mm
 M12 to M24: 1.5 mm
 M27 and above: 2 mm
 Standard thread pitch should be omitted in the ordering number, others should be specified.
- For oxygen-enriched environment or hazardous media service, contact FITOK Group or our authorized distributors.
- Cleaning and Packaging:
 FC-01: Standard cleaning and packaging for wetted system components to ensure compliance with product cleanliness requirements of ASTM G93 Level C
 FC-02: Special cleaning and packaging for general industrial procedures.
- For more information about pneumatic actuator ball valves, please refer to the catalog **Automatic Control Ball Valves**.
- CE certification is available. For more information, please contact FITOK group or our authorized distributors

Note: "Ordering Number Description" is a reference to understand the combination rules of FITOK product part number. Not all combinations are available.

Hex Bar Stock Ball Valves

BR Series

Features

- ⦿ Working pressure up to: 1000 psig (69.0 bar)
- ⦿ Working temperature: -20°F to 450°F (-28°C to 232°C)
- ⦿ Compact and economical design
- ⦿ Free floating ball design for seat wear compensation
- ⦿ Bi-directional flow
- ⦿ Low operating torque
- ⦿ Any reasonable connections available
- ⦿ Blowout proof stem
- ⦿ Handle color options available
- ⦿ Leak-tight performance testing with nitrogen or compressed air for every valve at the rated pressure to meet the requirement of no visible leak



Pressure vs. Temperature

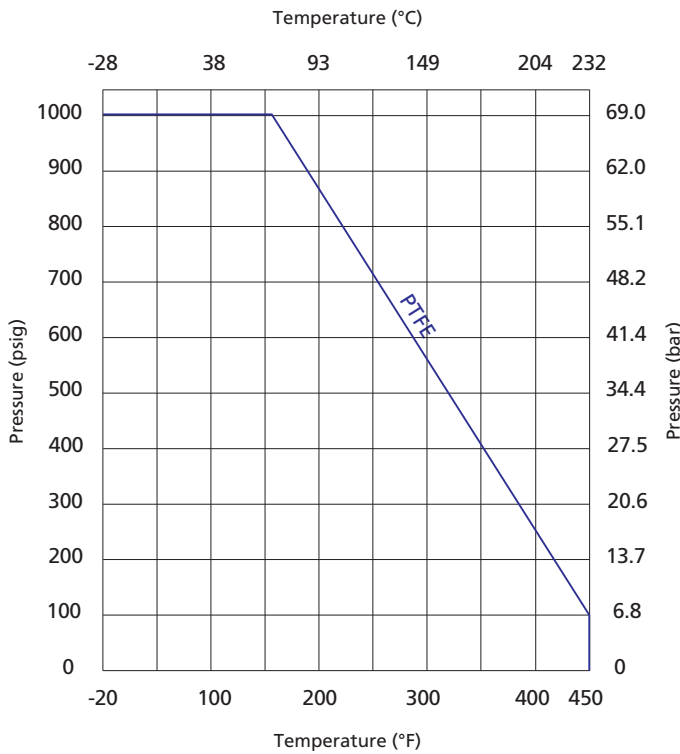

Standard Materials of Construction

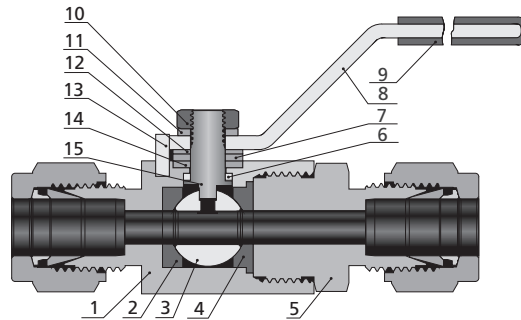

Item	Component	Valve Body Material			
		316 SS	304 SS	316L SS	Brass
1	<i>Body</i>	<i>316 SS/A479</i>	<i>304 SS/A479</i>	<i>316L SS/A479</i>	<i>Brass C36000/B16</i>
2	<i>Front Seat</i>	<i>PTFE/D1710</i>			
3	<i>Ball</i>	<i>316 SS/A479</i>	<i>304 SS/A479</i>	<i>316L SS/A479</i>	<i>316 SS/A479</i>
4	<i>Back Seat</i>	<i>PTFE/D1710</i>			
5	<i>End Connection</i>	<i>316 SS/A479</i>	<i>304 SS/A479</i>	<i>316L SS/A479</i>	<i>Brass C36000/B16</i>
6	<i>Lower Packing</i>	<i>PTFE/D1710</i>			
7	Washer	316 SS/A479			
8	Handle	304 SS/A240 or Aluminium			
9	Sleeve	Vinyl			
10	Stem Nut	SS			
11	Gasket	SS			
12	Coned-disk Spring	S17700/A693			
13	Stop Pin	SS			
14	<i>Upper Packing</i>	<i>PTFE/D1710</i>			
15	<i>Stem</i>	<i>316 SS/A479</i>	<i>304 SS/A479</i>	<i>316L SS/A479</i>	<i>316 SS/A479</i>

Note: Wetted components are listed in italics.
 For other materials, please contact FITOK Group or our authorized distributors.

Dimensions

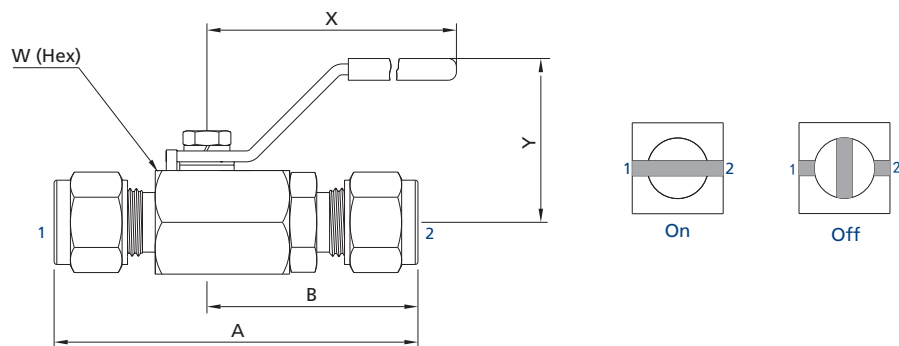

Ball Valves
Plug Valves

B-44 Ball Valves

Basic Ordering Number	Connection Type and Size		Orifice in. (mm)	Cv	Dimensions, in. (mm)				
	Connection 1	Connection 2			A	B	W	X	Y
BR□□-ML6-05	6 mm FITOK	6 mm FITOK	0.19 (4.8)	1.25	2.57 (65.2)	1.50 (38.1)	3/4 (19.05)	2.36 (60)	1.18 (30)
BR□□-ML8-05	8 mm FITOK	8 mm FITOK			2.63 (66.8)	1.53 (38.8)			
BR□□-FL4-05	1/4" FITOK	1/4" FITOK			2.57 (65.2)	1.50 (38.1)			
BR□□-FL5-05	5/16" FITOK	5/16" FITOK			2.63 (66.8)	1.53 (38.8)			
BR□□-FNS2-05	1/8 Female NPT	1/8 Female NPT			1.85 (47.0)	1.08 (27.4)			
BR□□-FRP2-05	1/8 Female BSPP	1/8 Female BSPP			2.00 (50.0)	1.14 (29.0)			
BR□□-FRP4-05	1/4 Female BSPP	1/4 Female BSPP			2.00 (50.0)	1.14 (29.0)			
BR□□-FNS4-05	1/4 Female NPT	1/4 Female NPT			1.85 (47.0)	1.08 (27.4)			
BR□□-ML10-07	10 mm FITOK	10 mm FITOK	0.28 (7.1)	2.50	2.87 (72.9)	1.68 (42.7)	7/8 (22.23)	1.26 (32)	
BR□□-FL6-07	3/8" FITOK	3/8" FITOK			2.03 (51.6)	1.18 (30.0)			
BR□□-FRP6-07	3/8 Female BSPP	3/8 Female BSPP							
BR□□-FNS6-07	3/8 Female NPT	3/8 Female NPT							
BR□□-ML12-10	12 mm FITOK	12 mm FITOK	0.35 (8.9)	9.25	3.15 (80.0)	1.83 (46.5)	1 1/16 (27.0)	3.15 (80)	1.54 (39)
BR□□-ML14-10	14 mm FITOK	14 mm FITOK			3.24 (82.2)	1.87 (47.5)			
BR□□-FL8-10	1/2" FITOK	1/2" FITOK			3.15 (80.0)	1.83 (46.5)			
BR□□-FL10-10	5/8" FITOK	5/8" FITOK			3.24 (82.2)	1.87 (47.5)			
BR□□-FRP8-10	1/2 Female BSPP	1/2 Female BSPP			2.08 (53.0)	1.12 (28.5)	15/16 (24.0)		
BR□□-FNS8-10	1/2 Female NPT	1/2 Female NPT			2.08 (53.0)	1.12 (28.5)			
BR□□-ML16-13	16 mm FITOK	16 mm FITOK	0.47 (12.0)	12.65	3.50 (88.9)	2.00 (50.8)	1 1/4 (31.75)	3.94 (100)	2.03 (51.7)
BR□□-ML18-13	18 mm FITOK	18 mm FITOK			2.48 (63.0)	1.30 (33.0)			
BR□□-FL12-13	3/4" FITOK	3/4" FITOK							
BR□□-FRP12-13	3/4 Female BSPP	3/4 Female BSPP			2.39 (60.7)	1.20 (30.5)			
BR□□-FNS12-13	3/4 Female NPT	3/4 Female NPT							
BR□□-ML22-16	22 mm FITOK	22 mm FITOK	0.63 (16.0)	17.35	3.96 (100.6)	2.24 (57.1)	1 1/2 (38.1)	2.15 (54.8)	
BR□□-ML25-16	25 mm FITOK	25 mm FITOK			4.31 (109.5)	2.42 (61.5)			
BR□□-FL16-16	1" FITOK	1" FITOK			3.25 (82.6)	1.63 (41.3)			
BR□□-FRP16-16	1 Female BSPP	1 Female BSPP			3.00 (76.5)	1.50 (38.1)			
BR□□-FNS16-16	1 Female NPT	1 Female NPT							

1. FITOK means FITOK double ferrule tube fittings.

2. Sizes and types listed are standard. Other sizes and types are available upon request, please contact FITOK Group or our authorized distributors.

3. Dimensions are shown with tube fitting nuts finger-tightened. All dimensions are for reference only and are subject to change.

For dimensions not shown above, please contact FITOK Group or our authorized distributors.

Ordering Number Description

BRSS - ML8 - FL4 - 05 - UL - SF2

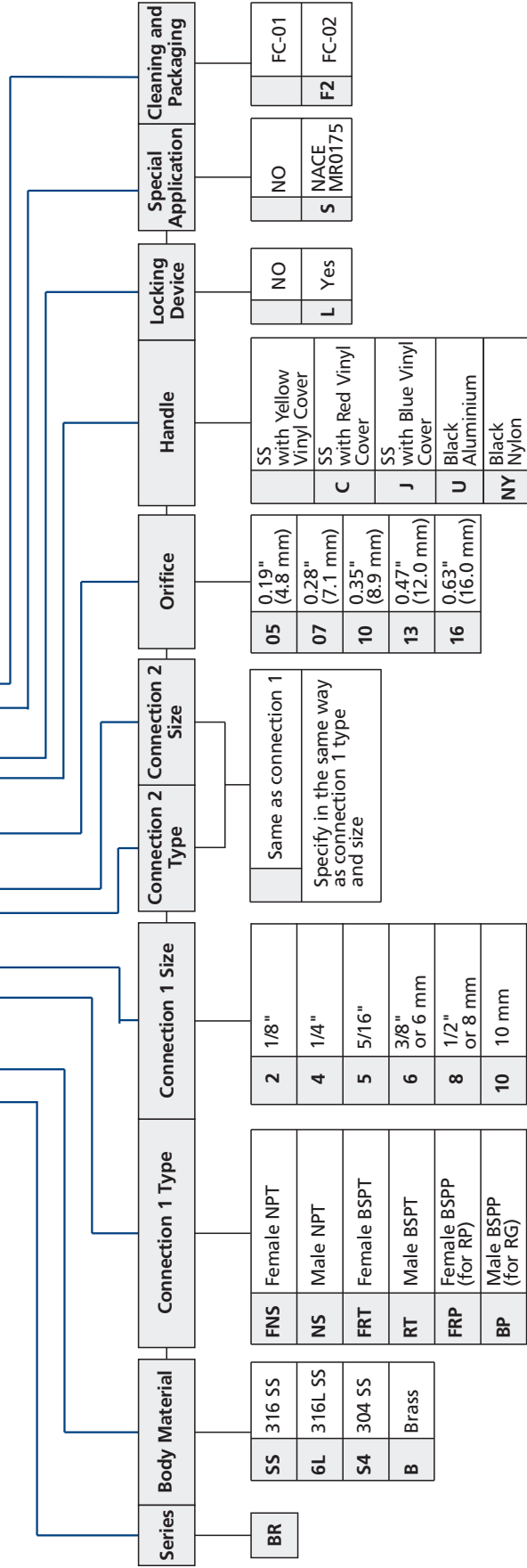

Series	Body Material	Connection 1 Type	Connection 1 Size	Connection 2 Type	Connection 2 Size	Orifice	Handle	Locking Device	Special Application	Cleaning and Packaging
BR	SS 316 SS 6L 316L SS S4 304 SS B Brass	FNS Female NPT NS Male NPT FRT Female BSPT RT Male BSPT FRP Female BSPP (for RP) BP Male BSPP (for RG) FL Fractional Tube Fitting ML Metric Tube Fitting UFB Nut + Gasket + Fractional Tube Bulged Nipple UMB Nut + Gasket + Metric Tube Bulged Nipple UPB Nut + Gasket + Pipe Bulged Nipple	2 1/8" 4 1/4" 5 5/16" 6 3/8" or 6 mm 8 1/2" or 8 mm 10 10 mm 12 3/4" or 12 mm 14 14 mm or M14 x 1.5 16 1" or 16 mm 18 18 mm 20 1 1/4" or 20 mm or M20 x 1.5 22 22 mm or M22 x 1.5 25 25 mm	Same as connection 1 Specify in the same way as connection 1 type and size	05 0.19" (4.8 mm) 07 0.28" (7.1 mm) 10 0.35" (8.9 mm) 13 0.47" (12.0 mm) 16 0.63" (16.0 mm)	SS with Yellow Vinyl Cover C with Red Vinyl Cover SS with Blue Vinyl Cover Black Aluminium NY Nylon	NO L Yes	NO S NACE MR0175	FC-01 FC-02 F2	

Note: "Ordering Number Description" is a reference to understand the combination rules of FITOK product part number. Not all combinations are available.

1. Standard thread pitch for metric threads are as follows:

M10 and below: 1 mm

M12 to M24: 1.5 mm

M27 and above: 2 mm

Standard thread pitch should be omitted in the ordering number, others should be specified.
2. For oxygen-enriched environment or hazardous media service, contact FITOK Group or our authorized distributors.

3. Cleaning and Packaging:

FC-01: Standard cleaning and packaging for general industrial procedures.

FC-02: Special cleaning and packaging for wetted system components to ensure compliance with product cleaning requirement of ASTM G93 Level C.

High Performance Ball Valves

BV Series

Features

- ⦿ Working pressure up to: 6000 psig (414 bar)
- ⦿ Working temperature: -65°F to 450°F (-54°C to 232°C)
- ⦿ Low operating torque
- ⦿ Handle as indicator of flow direction
- ⦿ Positive handle stop
- ⦿ Electric and pneumatic actuator available
- ⦿ Handle color options available
- ⦿ Leak-tight performance testing with nitrogen or compressed air for every valve to meet the requirement of no visible leakage at the rated pressure
- ⦿ Bi-directional flow for straight valves
- ⦿ The inlet of 3-way valves and angle pattern valves can only be the bottom port



Pressure vs. Temperature

316 SS Body

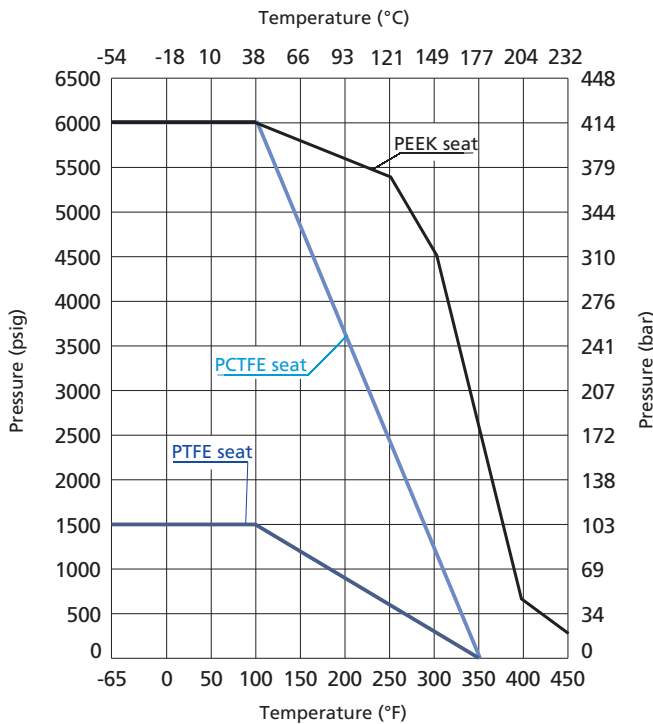

Brass Body

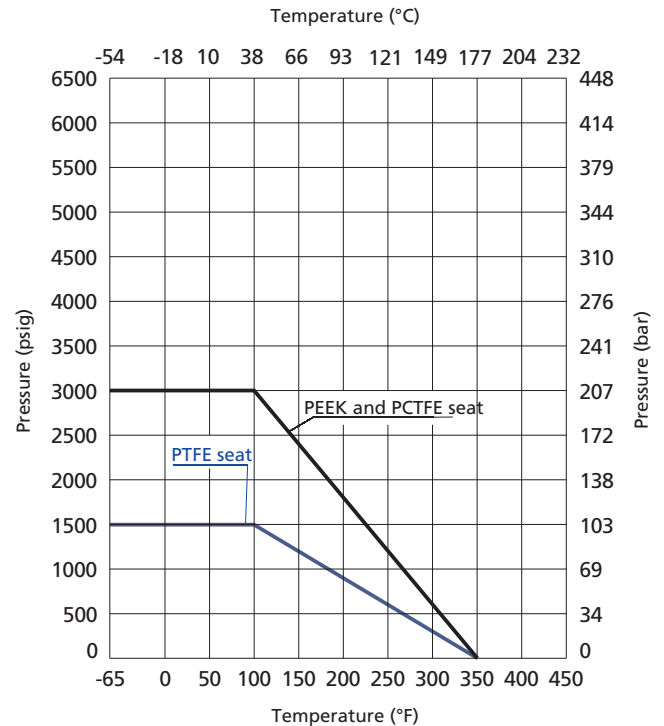

Note: The working pressure of valves is restricted by materials of the valve body and seat, as well as end connections. When choosing a valve for your applications, please refer to the above Temperature vs. Pressure Curves and the pressure rating in the dimension table. The minimum value shall be the pressure rating of the valve.

Standard Materials of Construction

Straight Valves

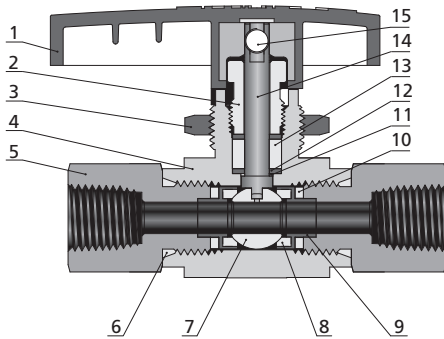

Item	Component	Valve Body Material	
		SS	Brass
1	Handle	Nylon or Aluminium	
2	Packing Nut	316 SS/A479	C36000/B16
3	Panel Nut	316 SS/A479	
4	<i>Body</i>	<i>CF8M/A351</i>	<i>C37700/B283</i>
5	<i>End Connection</i>	<i>316 SS/A479</i>	<i>C36000/B16</i>
6	<i>Connection O-ring</i>	PTFE	
7	<i>Ball</i>	<i>316 SS/A479</i>	
8	<i>Seat</i>	<i>PTFE or PCTFE or PEEK</i>	
9	<i>Seat Retainer</i>	<i>316 SS/A479</i>	
10	<i>Seat Packing</i>	PTFE	
11	<i>Stem Back-up Ring</i>	PEEK	
12	<i>Stem Washer</i>	<i>316/A479</i>	
13	<i>Stem Packing</i>	PTFE	
14	<i>Stem</i>	<i>316 SS/A479</i>	
15	<i>Set Screw</i>	<i>Galvanized carbon steel</i>	
	<i>Lubricants</i>	<i>Fluorinated-based</i>	

Note: Wetted components are listed in italics.

For other materials, please contact FITOK Group or our authorized distributors.

3-way Valves

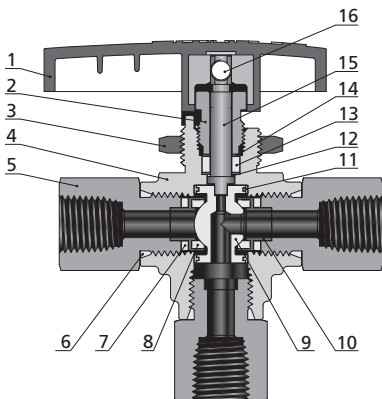

Item	Component	Valve Body Material	
		SS	Brass
1	Handle	Nylon or Aluminium	
2	Packing Nut	316 SS/A479	C36000/B16
3	Panel Nut	316 SS/A479	
4	<i>Body</i>	<i>CF8M/A351</i>	<i>C37700/B283</i>
5	<i>End Connection</i>	<i>316 SS/A479</i>	<i>C36000/B16</i>
6	<i>Connection O-ring</i>	PTFE	
7	<i>Seat Packing</i>	PTFE	
8	<i>Seat</i>	<i>PTFE or PCTFE or PEEK</i>	
9	<i>Ball</i>	<i>316 SS/A479</i>	
10	<i>Seat Retainer</i>	<i>316 SS/A479</i>	
11	<i>Trunnion Bearing</i>	PEEK	
12	<i>Stem Back-up Ring</i>	PEEK	
13	<i>Stem Packing</i>	PTFE	
14	<i>Stem Washer</i>	<i>316 SS/A479</i>	
15	<i>Stem</i>	<i>316 SS/A479</i>	
16	<i>Set Screw</i>	<i>Galvanized carbon steel</i>	
	<i>Lubricants</i>	<i>Fluorinated-based</i>	

Note: Wetted components are listed in italics.

For other materials, please contact FITOK Group or our authorized distributors.

Angle Pattern Valves

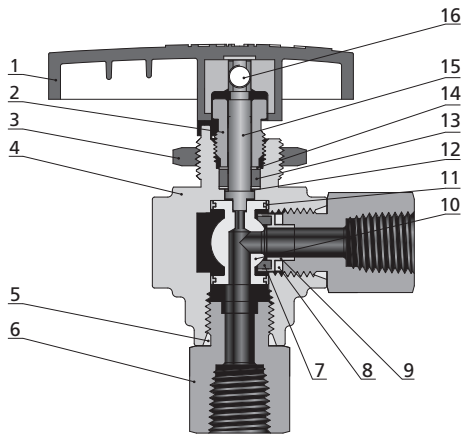

Item	Component	Valve Body Material	
		SS	Brass
1	Handle	Nylon or Aluminium	
2	Packing Nut	316 SS/A479	C36000/B16
3	Panel Nut	316 SS/A479	
4	Body	CF8M/A351	C37700/B283
5	Connection O-ring	PTFE	
6	End Connection	316 SS/A479	C36000/B16
7	Seat	PTFE or PCTFE or PEEK	
8	Seat Packing	PTFE	
9	Seat Retainer	316 SS/A479	
10	Ball	316 SS/A479	
11	Trunnion Bearing	PEEK	
12	Stem Back-up Ring	PEEK	
13	Stem Packing	PTFE	
14	Stem Washer	316 SS/A479	
15	Stem	316 SS/A479	
16	Set Screw	Galvanized carbon Steel	
	Lubricants	Fluorinated-based	

Note: Wetted components are listed in italics.
For other materials, please contact FITOK Group or our authorized distributors.

Dimensions

Straight Valves

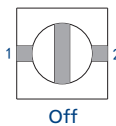
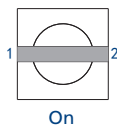
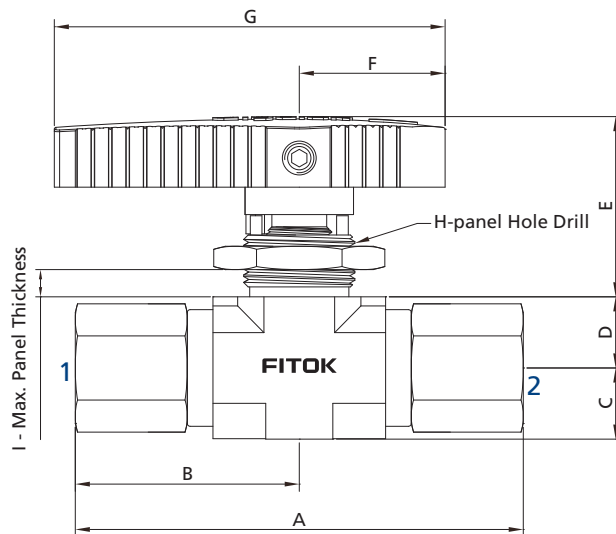

Basic Ordering Number	Connection Type and Size	Pressure Rating of End Connections @ 100°F (38°C)		Orifice in. (mm)	Cv	Dimensions, in. (mm)																						
		psig (bar)				A	B	C	D	E	F	G	H	I														
		316 SS	Brass																									
BV□□-FL1-01	1/16" FITOK	6000 (414)	3000 (207)	0.05 (1.3)	0.06	2.60 (66.0)	1.30 (33.0)																					
BV□□-FL2-02	1/8" FITOK	6000 (414)	3000 (207)	0.09 (2.4)	0.21	2.72 (69.0)	1.36 (34.5)																					
BV□□-ML3-02	3 mm FITOK	6000 (414)	3000 (207)			2.74 (69.6)	1.37 (34.8)																					
BV□□-FRT2-04	1/8 Female BSPT	6000 (414)	3000 (207)	0.17 (4.2)	0.93	2.14 (54.4)	1.07 (27.2)	0.36 (9.2)	0.33 (8.5)	0.94 (23.9)	0.79 (20.0)	1.97 (50.0)	0.58 (14.7)	0.18 (4.6)														
BV□□-FRP2-04	1/8 Female BSPP	6000 (414)	3000 (207)																									
BV□□-FNS2-04	1/8 Female NPT	6000 (414)	3000 (207)																									
BV□□-RT2-04	1/8 Male BSPT	6000 (414)	3000 (207)																									
BV□□-BP2-04	1/8 Male BSPP	6000 (414)	3000 (207)																									
BV□□-NS2-04	1/8 Male NPT	6000 (414)	3000 (207)			2.36 (60.0)	1.18 (30.0)																					
BV□□-RT4-04	1/4 Male BSPT	6000 (414)	3000 (207)																									
BV□□-BP4-04	1/4 Male BSPP	6000 (414)	3000 (207)																									
BV□□-NS4-04	1/4 Male NPT	6000 (414)	3000 (207)																									
BV□□-FL4-05	1/4" FITOK	6000 (414)	3000 (207)					0.19 (4.7)	1.04	3.48 (88.4)	1.74 (44.2)																	
BV□□-ML6-05	6 mm FITOK	6000 (414)	3000 (207)							3.50 (89.0)	1.75 (44.5)																	
BV□□-FL6-06	3/8" FITOK	6000 (414)	2200 (152)	0.25 (6.4)	2.34	3.60 (91.4)	1.80 (45.7)																					
BV□□-ML8-06	8 mm FITOK	6000 (414)	2300 (159)			3.56 (90.4)	1.78 (45.2)																					
BV□□-ML10-06	10 mm FITOK	6000 (414)	1900 (131)			3.62 (92.0)	1.81 (46.0)																					
BV□□-FRT4-06	1/4 Female BSPT	6000 (414)	3000 (207)			3.02 (76.8)	1.51 (38.4)	0.48 (12.2)	0.48 (12.2)	1.24 (31.5)	0.59 (25.0)	2.64 (67.0)	0.77 (19.6)	0.25 (6.4)														
BV□□-FRP4-06	1/4 Female BSPP	6000 (414)	3000 (207)																									
BV□□-FNS4-06	1/4 Female NPT	6000 (414)	3000 (207)																									
BV□□-RT4-06	1/4 Male BSPT	6000 (414)	3000 (207)																									
BV□□-BP4-06	1/4 Male BSPP	6000 (414)	3000 (207)																									
BV□□-NS4-06	1/4 Male NPT	6000 (414)	3000 (207)																									
BV□□-RT6-06	3/8 Male BSPT	6000 (414)	3000 (207)												3.24 (82.2)	1.62 (41.1)												
BV□□-BP6-06	3/8 Male BSPP	6000 (414)	3000 (207)																									
BV□□-NS6-06	3/8 Male NPT	6000 (414)	3000 (207)																									
BV□□-FL8-10	1/2" FITOK	6000 (414)	2100 (145)			0.41 (10.3)	6.42	4.68 (118.8)	2.34 (59.4)																			
BV□□-FL12-10	3/4" FITOK	5800 (400)	1800 (124)			0.37 (9.5)	5.57	4.66 (118.4)	2.33 (59.2)																			
BV□□-ML12-10	12 mm FITOK	6000 (414)	2000 (138)																									
BV□□-ML14-10	14 mm FITOK	6000 (414)	1900 (131)	0.41 (10.3)	6.42	4.84 (123.0)	2.42 (61.5)	0.75 (19.0)	0.71 (18.0)	1.54 (39.0)	1.42 (36.0)	3.78 (96.0)	0.90 (22.9)	0.38 (9.7)														
BV□□-ML16-10	16 mm FITOK	5800 (400)	1700 (117)																									
BV□□-ML18-10	18 mm FITOK	5400 (372)	1600 (110)																									
BV□□-ML20-10	20 mm FITOK	5500 (379)	1600 (110)																									
BV□□-ML22-10	22 mm FITOK	4900 (338)	1450 (100)																									
BV□□-FRT6-10	3/8 Female BSPT	6000 (414)	3000 (207)			3.90 (99.0)	1.95 (49.5)																					
BV□□-FRP6-10	3/8 Female BSPP	6000 (414)	3000 (207)																									
BV□□-FNS6-10	3/8 Female NPT	6000 (414)	3000 (207)																									
BV□□-FRT8-10	1/2 Female BSPT	6000 (414)	3000 (207)																									
BV□□-FRP8-10	1/2 Female BSPP	6000 (414)	3000 (207)																									
BV□□-FNS8-10	1/2 Female NPT	6000 (414)	3000 (207)																									
BV□□-FRT12-10	3/4 Female BSPT	6000 (414)	3000 (207)	4.50 (114.2)	2.25 (57.1)																							
BV□□-FRP12-10	3/4 Female BSPP	6000 (414)	3000 (207)																									
BV□□-FNS12-10	3/4 Female NPT	6000 (414)	3000 (207)																									
BV□□-RT8-10	1/2 Male BSPT	6000 (414)	3000 (207)			4.44 (112.8)	2.22 (56.4)																					
BV□□-BP8-10	1/2 Male BSPP	6000 (414)	3000 (207)																									
BV□□-NS8-10	1/2 Male NPT	6000 (414)	3000 (207)																									
BV□□-RT12-10	3/4 Male BSPT	6000 (414)	3000 (207)																									
BV□□-BP12-10	3/4 Male BSPP	6000 (414)	3000 (207)																									
BV□□-NS12-10	3/4 Male NPT	6000 (414)	3000 (207)																									

3-way Valves

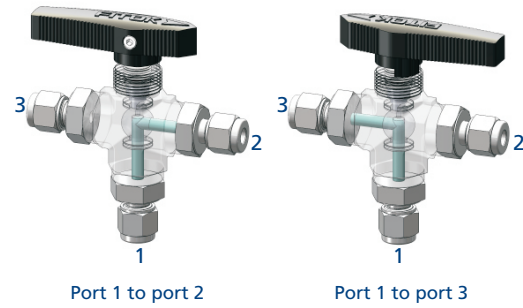
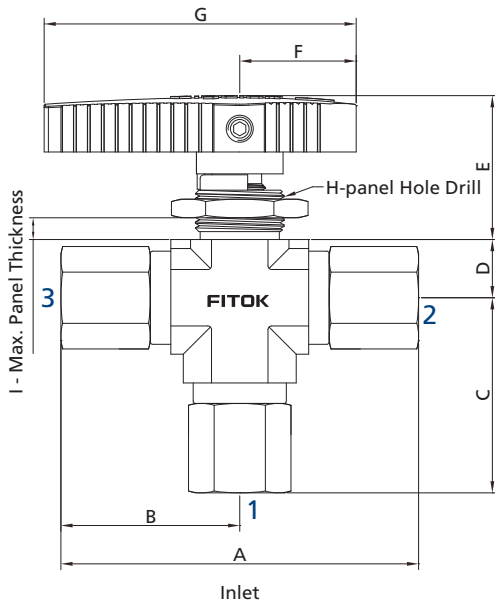

Ball Valves
Plug Valves

Basic Ordering Number	Connection Type and Size	Pressure Rating of End Connections @ 100°F (38°C), psig (bar)		Orifice in. (mm)	Cv	Dimensions, in. (mm)													
		316 SS	Brass			A	B	C	D	E	F	G	H	I					
BV□□-FL1-01-3	1/16" FITOK	6000 (414)	3000 (207)	0.05 (1.3)	0.06	2.60 (66.0)	1.30 (33.0)	1.35 (34.3)											
BV□□-FL2-02-3	1/8" FITOK	6000 (414)	3000 (207)	0.09 (2.4)	0.21	2.72 (69.0)	1.36 (34.5)	1.41 (35.8)											
BV□□-ML3-02-3	3 mm FITOK	6000 (414)	3000 (207)			2.74 (69.6)	1.37 (34.8)	1.42 (36.1)											
BV□□-FRT2-04-3	1/8 Female BSPT	6000 (414)	3000 (207)	0.12 (3.0)	0.28	2.14 (54.4)	1.07 (27.2)	1.12 (28.5)											
BV□□-FRP2-04-3	1/8 Female BSPP	6000 (414)	3000 (207)																
BV□□-FNS2-04-3	1/8 Female NPT	6000 (414)	3000 (207)								0.33 (8.5)	0.94 (23.9)	0.79 (20.0)	1.97 (50.0)	0.58 (14.7)	0.18 (4.6)			
BV□□-RT2-04-3	1/8 Male BSPT	6000 (414)	3000 (207)					2.36 (60.0)	1.18 (30.0)	1.23 (31.3)									
BV□□-BP2-04-3	1/8 Male BSPP	6000 (414)	3000 (207)																
BV□□-NS2-04-3	1/8 Male NPT	6000 (414)	3000 (207)																
BV□□-RT4-04-3	1/4 Male BSPT	6000 (414)	3000 (207)																
BV□□-BP4-04-3	1/4 Male BSPP	6000 (414)	3000 (207)					2.70 (68.6)	1.35 (34.3)	1.40 (35.6)									
BV□□-NS4-04-3	1/4 Male NPT	6000 (414)	3000 (207)																
BV□□-FL4-05-3	1/4" FITOK	6000 (414)	3000 (207)			0.19 (4.7)	0.70	3.48 (88.4)	1.74 (44.2)	1.88 (47.7)									
BV□□-ML6-05-3	6 mm FITOK	6000 (414)	3000 (207)					3.50 (89.0)	1.75 (44.5)	1.89 (48.0)									
BV□□-FL6-06-3	3/8" FITOK	6000 (414)	3000 (207)					3.60 (91.4)	1.80 (45.7)	1.94 (49.2)									
BV□□-ML8-06-3	8 mm FITOK	6000 (414)	3000 (207)					3.56 (90.4)	1.78 (45.2)	1.92 (48.7)									
BV□□-ML10-06-3	10 mm FITOK	6000 (414)	3000 (207)					3.62 (92.0)	1.81 (46.0)	1.95 (49.5)									
BV□□-FRT4-06-3	1/4 Female BSPT	6000 (414)	3000 (207)																
BV□□-FRP4-06-3	1/4 Female BSPP	6000 (414)	3000 (207)					3.02 (76.8)	1.51 (38.4)	1.65 (41.9)	0.48 (12.2)	1.24 (31.5)	0.59 (25.0)	2.64 (67.0)	0.77 (19.6)	0.25 (6.4)			
BV□□-FNS4-06-3	1/4 Female NPT	6000 (414)	3000 (207)																
BV□□-RT4-06-3	1/4 Male BSPT	6000 (414)	3000 (207)																
BV□□-BP4-06-3	1/4 Male BSPP	6000 (414)	3000 (207)																
BV□□-NS4-06-3	1/4 Male NPT	6000 (414)	3000 (207)																
BV□□-RT6-06-3	3/8 Male BSPT	6000 (414)	3000 (207)			3.24 (82.2)	1.62 (41.1)	1.76 (44.6)											
BV□□-BP6-06-3	3/8 Male BSPP	6000 (414)	3000 (207)																
BV□□-NS6-06-3	3/8 Male NPT	6000 (414)	3000 (207)																

Basic Ordering Number	Connection Type and Size	Pressure Rating of End Connections @ 100°F (38°C), psig (bar)		Orifice in. (mm)	Cv	Dimensions, in. (mm)								
		316 SS	Brass			A	B	C	D	E	F	G	H	I
BV□□-FL8-10-3	1/2" FITOK	6000 (414)	2100 (145)	0.37 (9.5)	3.48	4.68 (118.8)	2.34 (59.4)	2.68 (68.1)	0.71 (18.0)	1.54 (39.0)	1.42 (36.0)	3.78 (96.0)	0.90 (22.9)	0.38 (9.7)
BV□□-FL12-10-3	3/4" FITOK	5800 (400)	1800 (124)			4.66 (118.4)	2.33 (59.2)	2.67 (67.9)						
BV□□-ML12-10-3	12 mm FITOK	6000 (414)	2000 (138)			4.84 (123.0)	2.42 (61.5)	2.76 (70.2)						
BV□□-ML14-10-3	14 mm FITOK	6000 (414)	1900 (131)											
BV□□-ML16-10-3	16 mm FITOK	5800 (400)	1700 (117)			3.90 (99.0)	1.95 (49.5)	2.29 (58.2)						
BV□□-ML18-10-3	18 mm FITOK	5400 (372)	1600 (110)											
BV□□-ML20-10-3	20 mm FITOK	5500 (379)	1600 (110)			4.30 (109.2)	2.15 (54.6)	2.49 (63.3)						
BV□□-ML22-10-3	22 mm FITOK	4900 (338)	1450 (100)											
BV□□-FRT6-10-3	3/8 Female BSPT	6000 (414)	3000 (207)			3.97 (101.0)	1.99 (50.5)	2.33 (59.1)						
BV□□-FRP6-10-3	3/8 Female BSPP	6000 (414)	3000 (207)											
BV□□-FNS6-10-3	3/8 Female NPT	6000 (414)	3000 (207)			4.30 (109.2)	2.15 (54.6)	2.49 (63.3)						
BV□□-FRT8-10-3	1/2 Female BSPT	6000 (414)	3000 (207)											
BV□□-FRP8-10-3	1/2 Female BSPP	6000 (414)	3000 (207)			4.50 (114.2)	2.25 (57.1)	2.59 (65.8)						
BV□□-FNS8-10-3	1/2 Female NPT	6000 (414)	3000 (207)											
BV□□-FRT12-10-3	3/4 Female BSPT	6000 (414)	3000 (207)			4.44 (112.8)	2.22 (56.4)	2.56 (65.1)						
BV□□-FRP12-10-3	3/4 Female BSPP	6000 (414)	3000 (207)											
BV□□-FNS12-10-3	3/4 Female NPT	6000 (414)	3000 (207)											
BV□□-RT8-10-3	1/2 Male BSPT	6000 (414)	3000 (207)											
BV□□-BP8-10-3	1/2 Male BSPP	6000 (414)	3000 (207)											
BV□□-NS8-10-3	1/2 Male NPT	6000 (414)	3000 (207)											
BV□□-RT12-10-3	3/4 Male BSPT	6000 (414)	3000 (207)											
BV□□-BP12-10-3	3/4 Male BSPP	6000 (414)	3000 (207)											
BV□□-NS12-10-3	3/4 Male NPT	6000 (414)	3000 (207)											

Angle Pattern Valves

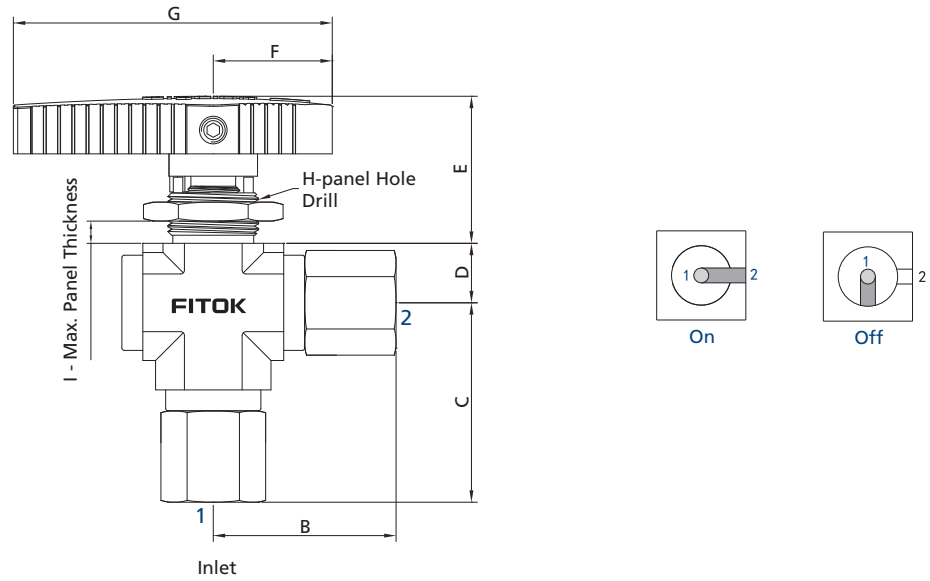

Basic Ordering Number	Connection Type and Size	Pressure Rating of End Connections @ 100°F (38°C), psig (bar)		Orifice in. (mm)	Cv	Dimensions, in. (mm)									
		316 SS	Brass			B	C	D	E	F	G	H	I		
BV□□-FL1-01-A	1/16" FITOK	6000 (414)	3000 (207)	0.05 (1.3)	0.06	1.30 (33.0)	1.35 (34.3)								
BV□□-FL2-02-A	1/8" FITOK	6000 (414)	3000 (207)	0.09 (2.4)	0.21	1.36 (34.5)	1.41 (35.8)								
BV□□-ML3-02-A	3 mm FITOK	6000 (414)	3000 (207)			1.37 (34.8)	1.42 (36.1)								
BV□□-FRT2-04-A	1/8 Female BSPT	6000 (414)	3000 (207)	0.12 (3.0)	0.28	1.07 (27.2)	1.12 (28.5)								
BV□□-FRP2-04-A	1/8 Female BSPP	6000 (414)	3000 (207)												
BV□□-FNS2-04-A	1/8 Female NPT	6000 (414)	3000 (207)					0.33 (8.5)	0.94 (23.9)	0.79 (20.0)	1.97 (50.0)	0.58 (14.7)	0.18 (4.6)		
BV□□-RT2-04-A	1/8 Male BSPT	6000 (414)	3000 (207)					1.18 (30.0)	1.23 (31.3)						
BV□□-BP2-04-A	1/8 Male BSPP	6000 (414)	3000 (207)												
BV□□-NS2-04-A	1/8 Male NPT	6000 (414)	3000 (207)												
BV□□-RT4-04-A	1/4 Male BSPT	6000 (414)	3000 (207)												
BV□□-BP4-04-A	1/4 Male BSPP	6000 (414)	3000 (207)					1.35 (34.3)	1.40 (35.6)						
BV□□-NS4-04-A	1/4 Male NPT	6000 (414)	3000 (207)												
BV□□-FL4-05-A	1/4" FITOK	6000 (414)	3000 (207)			0.19 (4.7)	0.70	1.74 (44.2)	1.88 (47.7)						
BV□□-ML6-05-A	6 mm FITOK	6000 (414)	3000 (207)					1.75 (44.5)	1.89 (48.0)						
BV□□-FL6-06-A	3/8" FITOK	6000 (414)	2200 (152)					1.80 (45.7)	1.94 (49.2)						
BV□□-ML8-06-A	8 mm FITOK	6000 (414)	2300 (159)					1.78 (45.2)	1.92 (48.7)						
BV□□-ML10-06-A	10 mm FITOK	6000 (414)	1900 (131)					1.81 (46.0)	1.95 (49.5)						
BV□□-FRT4-06-A	1/4 Female BSPT	6000 (414)	3000 (207)												
BV□□-FRP4-06-A	1/4 Female BSPP	6000 (414)	3000 (207)					1.51 (38.4)	1.65 (41.9)	0.48 (12.2)	1.24 (31.5)	0.59 (25.0)	2.64 (67.0)	0.77 (19.6)	0.25 (6.4)
BV□□-FNS4-06-A	1/4 Female NPT	6000 (414)	3000 (207)												
BV□□-RT4-06-A	1/4 Male BSPT	6000 (414)	3000 (207)												
Bv□□-BP4-06-A	1/4 Male BSPP	6000 (414)	3000 (207)												
BV□□-NS4-06-A	1/4 Male NPT	6000 (414)	3000 (207)			1.62 (41.1)	1.76 (44.6)								
BV□□-RT6-06-A	3/8 Male BSPT	6000 (414)	3000 (207)												
BV□□-BP6-06-A	3/8 Male BSPP	6000 (414)	3000 (207)												
BV□□-NS6-06-A	3/8 Male NPT	6000 (414)	3000 (207)												

Basic Ordering Number	Connection Type and Size	Pressure Rating of End Connections @ 100°F (38°C), psig (bar)		Orifice in. (mm)	Cv	Dimensions, in. (mm)							
		316 SS	Brass			B	C	D	E	F	G	H	I
BV□□-FL8-10-A	1/2" FITOK	6000 (414)	2100 (145)	0.37 (9.5)	3.48	2.34(59.4)	2.68(68.1)	0.71 (18.0)	1.54 (39.0)	1.42 (36.0)	3.78 (96.0)	0.90 (22.9)	0.38 (9.7)
BV□□-FL12-10-A	3/4" FITOK	5800 (400)	1800 (124)										
BV□□-ML12-10-A	12 mm FITOK	6000 (414)	2000 (138)										
BV□□-ML14-10-A	14 mm FITOK	6000 (414)	1900 (131)										
BV□□-ML16-10-A	16 mm FITOK	5800 (400)	1700 (117)										
BV□□-ML18-10-A	18 mm FITOK	5400 (372)	1600 (110)										
BV□□-ML20-10-A	20 mm FITOK	5500 (379)	1600 (110)										
BV□□-ML22-10-A	22 mm FITOK	4900 (338)	1450 (100)										
BV□□-FRT6-10-A	3/8 Female BSPT	6000 (414)	3000 (207)										
BV□□-FRP6-10-A	3/8 Female BSPP	6000 (414)	3000 (207)										
BV□□-FNS6-10-A	3/8 Female NPT	6000 (414)	3000 (207)										
BV□□-FRT8-10-A	1/2 Female BSPT	6000 (414)	3000 (207)										
BV□□-FRP8-10-A	1/2 Female BSPP	6000 (414)	3000 (207)										
BV□□-FNS8-10-A	1/2 Female NPT	6000 (414)	3000 (207)										
BV□□-FRT12-10-A	3/4 Female BSPT	6000 (414)	3000 (207)										
BV□□-FRP12-10-A	3/4 Female BSPP	6000 (414)	3000 (207)										
BV□□-FNS12-10-A	3/4 Female NPT	6000 (414)	3000 (207)										
BV□□-RT8-10-A	1/2 Male BSPT	6000 (414)	3000 (207)										
BV□□-BP8-10-A	1/2 Male BSPP	6000 (414)	3000 (207)										
BV□□-NS8-10-A	1/2 Male NPT	6000 (414)	3000 (207)										
BV□□-RT12-10-A	3/4 Male BSPT	6000 (414)	3000 (207)										
BV□□-BP12-10-A	3/4 Male BSPP	6000 (414)	3000 (207)										
BV□□-NS12-10-A	3/4 Male NPT	6000 (414)	3000 (207)										

1. FITOK means FITOK double ferrule tube fittings.

2. Sizes and types listed are standard. Other sizes and types are available upon request, please contact FITOK Group or our authorized distributors.

3. Dimensions are shown with tube fitting nuts finger-tightened. All dimensions are for reference only and are subject to change.

For dimensions not shown above, please contact FITOK Group or our authorized distributors.

Ordering Number Description

BVSS - FL8 - ML12 - ML10 - P06 - RXHQ3 - SCEF2

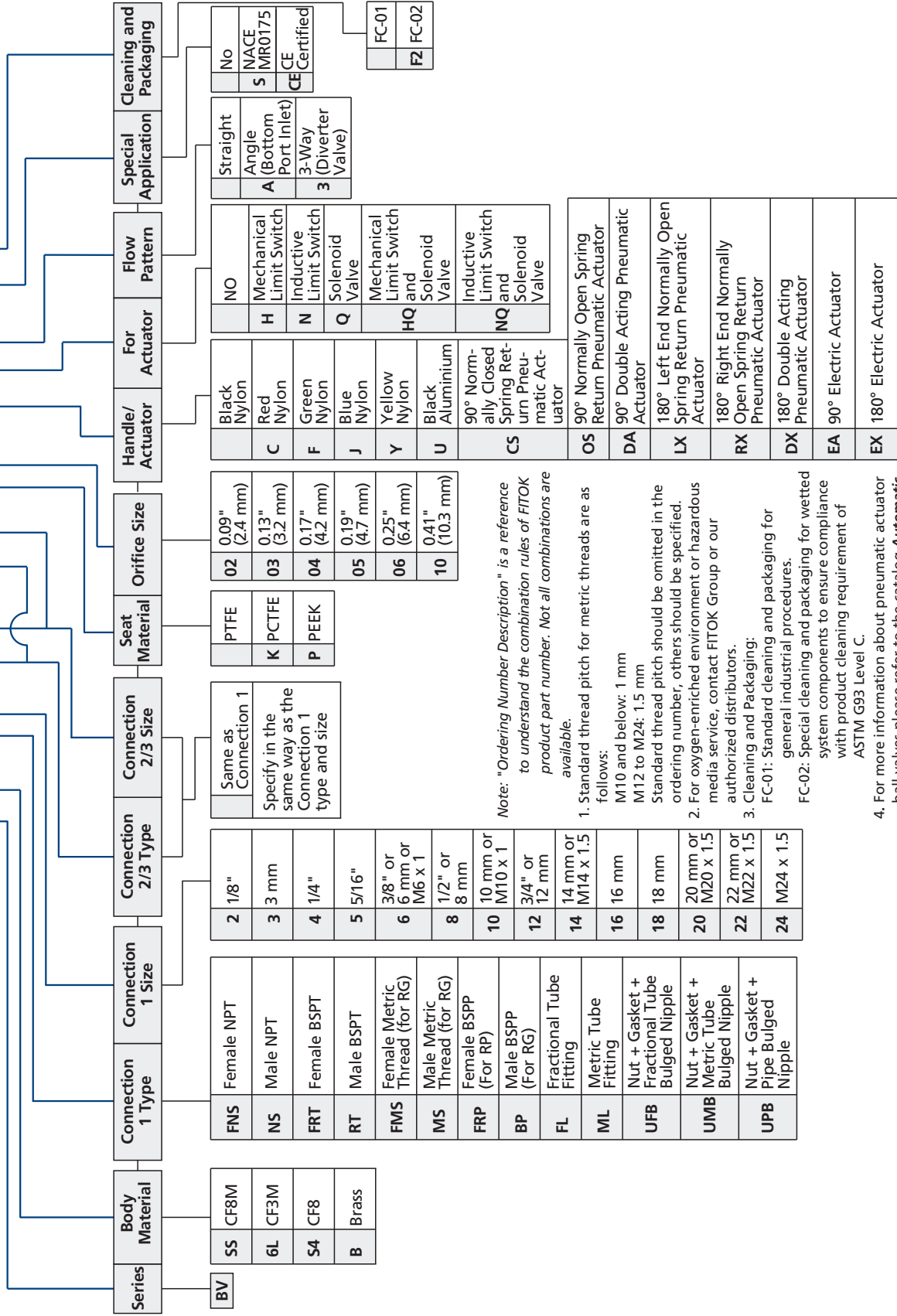

Series	Body Material	Connection 1 Type	Connection 1 Size	Connection 2/3 Type	Connection 2/3 Size	Seat Material	Orifice Size	Handle/Actuator	For Actuator	Flow Pattern	Special Application	Cleaning and Packaging
BV	SS CF8M	FNS Female NPT	2 1/8"	Same as Connection 1	02 0.09" (2.4 mm)	PTFE	Black Nylon	NO			Straight	No
	6L CF3M	NS Male NPT	3 3 mm	Specify in the same way as the Connection 1 type and size	03 0.13" (3.2 mm)	K PCTFE	Red Nylon	H Mechanical Limit Switch			Angle (Bottom Port Inlet)	INACE S IMR0175
	S4 CF8	FRT Female BSPT	4 1/4"		04 0.17" (4.2 mm)	P PEEK	Green Nylon	N Inductive Limit Switch			3-Way (Diverter Valve)	CE Certified
	B Brass	RT Male BSPT	5 5/16"		05 0.19" (4.7 mm)		Blue Nylon	Q Solenoid Valve				
		FMS Female Metric Thread (for RG)	6 3/8" or 6 mm or M6 x 1		06 0.25" (6.4 mm)		Yellow Nylon	HQ and Solenoid Valve				FC-01
		MS Male Metric Thread (for RG)	8 1/2" or 8 mm		10 0.41" (10.3 mm)		Black Aluminium					F2 FC-02
		FRP Female BSPP (For RP)	10 10 mm or M10 x 1				90° Normally Closed Spring Return Pneumatic Actuator					
		BP Male BSPP (For RG)	12 3/4" or 12 mm				CS					
		FL Fractional Tube Fitting	14 14 mm or M14 x 1.5				OS					
		ML Metric Tube Fitting	16 16 mm				DA					
		UFB Nut + Gasket + Fractional Tube Bulged Nipple	18 18 mm				LX					
		UMB Nut + Gasket + Metric Tube Bulged Nipple	20 20 mm or M20 x 1.5				RX					
		UPB Nut + Gasket + Pipe Bulged Nipple	22 22 mm or M22 x 1.5				DX					
			24 M24 x 1.5				EA					
							EX					

Note: "Ordering Number Description" is a reference to understand the combination rules of FITOK product part number. Not all combinations are available.

- Standard thread pitch for metric threads are as follows:
M10 and below: 1 mm
M12 to M24: 1.5 mm
Standard thread pitch should be omitted in the ordering number, others should be specified.
- For oxygen-enriched environment or hazardous media service, contact FITOK Group or our authorized distributors.
- Cleaning and Packaging:
FC-01: Standard cleaning and packaging for general industrial procedures.
FC-02: Special cleaning and packaging for wetted system components to ensure compliance with product cleaning requirement of ASTM G93 Level C.

4. For more information about pneumatic actuator ball valves, please refer to the catalog **Automatic Control Ball Valves**

5. CE certification is available. For more information, please contact FITOK group or our authorized distributors

High Temperature Metal-seated Ball Valves

BK Series

Features

- ⦿ 3-piece precision cast body construction
- ⦿ Free floating ball design provides seat wear compensation
- ⦿ Ball and seats mate-lapped for 100% contact ensures absolute shutoff
- ⦿ High temperature resistant sealing materials for thermal service up to 662°F (350°C)
- ⦿ Blowout-proof stem
- ⦿ Positive handle stop
- ⦿ Orifice sizes: 0.5" (12.7 mm), 1" (25.4 mm), 1.5" (38.1 mm)
- ⦿ Variety of end connections
- ⦿ Every valve leak tested with Nitrogen or compressed air at working pressure

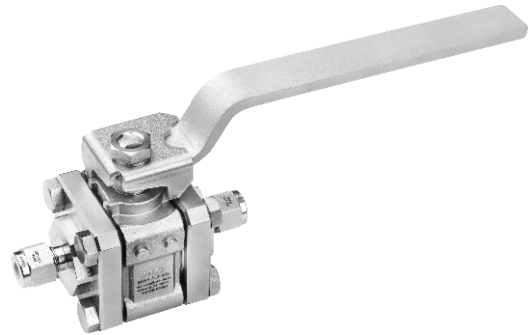

Technical Data

Orifice, in. (mm)	0.5 (12.7), 1 (25.4), 1.5 (38.1)	
Material	316/304 SS	
Connection Type	FITOK Tube Fitting	Weld Fitting
Temperature, °F (°C)	-65 (-54) to 662 (350)	
Working Pressure, psig (bar)	1000 (69)	

Standard Materials of Construction

Ball Valves
Plug Valves

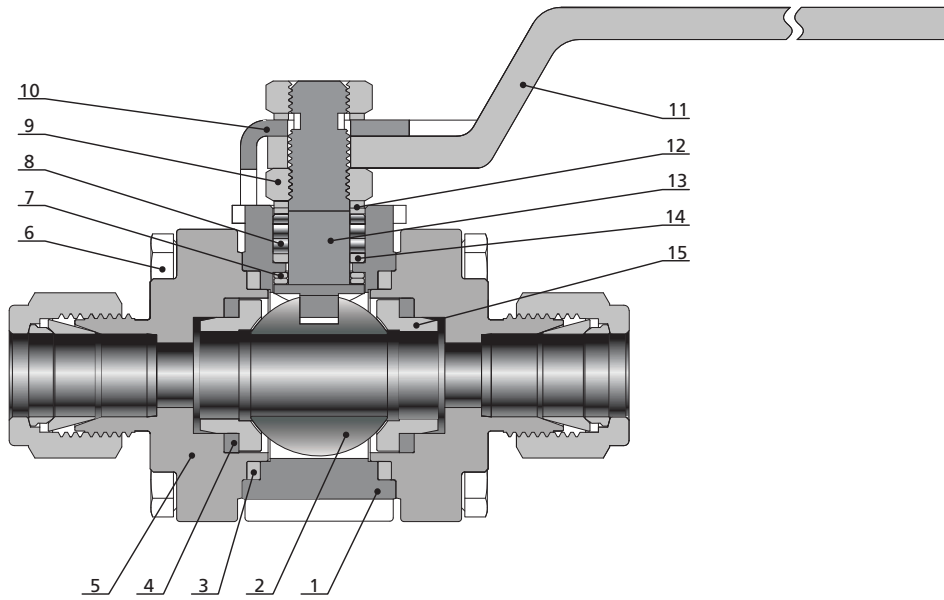

Item	Component	Material	
1	<i>Body</i>	<i>CF8M/A351</i>	<i>CF8/A351</i>
2	<i>Ball</i>	<i>316/304 SS, HVOF-sprayed WC coatings</i>	
3	<i>Flange Seal</i>	<i>Graphite</i>	
4	<i>Seat Packing</i>	<i>Graphite</i>	
5	<i>End Connection</i>	<i>CF8M/A351</i>	<i>CF8/A351</i>
6	Hex Bolt	Stainless Steel	
7	<i>Stem Bearing</i>	<i>Stellite 6/AMS5387</i>	
8	<i>Packing</i>	<i>Graphite</i>	
9	Hex Nut	316 SS/A479	
10	Stop Plate	304 SS/A240	
11	Handle	304 SS/A240	
12	Stem Spring	Strain-hardened 316 SS/A240	
13	<i>Stem</i>	<i>316 SS/A479</i>	
14	<i>Stem Washer</i>	<i>316 SS/A479</i>	
15	<i>Seat</i>	<i>316 SS/A479, hardfacing stellite</i>	<i>304 SS/A479, hardfacing stellite</i>

Note: Wetted components are listed in italics. For other materials, please contact FITOK Group or our authorized distributors.

Dimensions

Dimensions are for reference only and are subject to change.

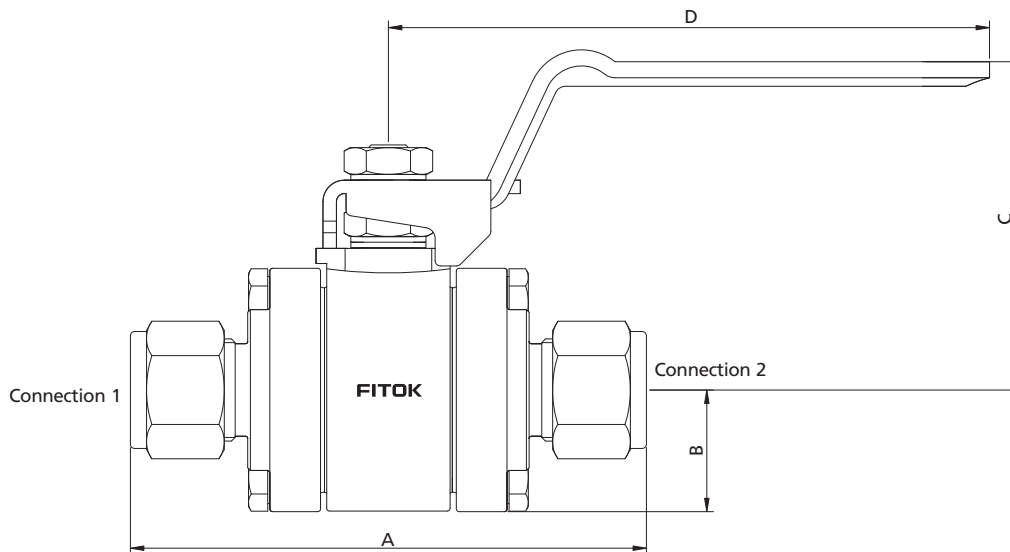

Basic Ordering Information	Connection Type		Orifice in. (mm)	Dimensions, in. (mm)			
	Connection 1	Connection 2		A	B	C	D
BK□□-FL8-13G	1/2" FITOK	1/2" FITOK	0.41 (10.4)	3.79" (96.2)	0.89" (22.7)	2.25" (57.1)	6.5" (165)
BK□□-FL10-13G	5/8" FITOK	5/8" FITOK	0.5 (12.7)	3.79" (96.2)	0.89" (22.7)	2.25" (57.1)	6.5" (165)
BK□□-FL12-13G	3/4" FITOK	3/4" FITOK		3.92" (99.6)	0.89" (22.7)	2.25" (57.1)	6.5" (165)
BK□□-ML16-13G	16 mm FITOK	16 mm FITOK		3.92" (99.6)	0.89" (22.7)	2.25" (57.1)	6.5" (165)
BK□□-ML18-13G	18 mm FITOK	18 mm FITOK		3.91" (99.4)	0.89" (22.7)	2.25" (57.1)	6.5" (165)
BK□□-TB12-13G	3/4" Tube Butt Weld	3/4" Tube Butt Weld		3.8" (96.6)	0.89" (22.7)	2.25" (57.1)	6.5" (165)
BK□□-TS12-13G	3/4" Tube Socket Weld	3/4" Tube Socket Weld		3.2" (80.2)	0.89" (22.7)	2.25" (57.1)	6.5" (165)
BK□□-PB8-13G	1/2" Pipe Butt Weld	1/2" Pipe Butt Weld		3.24" (82.34)	0.89" (22.7)	2.25" (57.1)	6.5" (165)
BK□□-PB12-13G	3/4" Pipe Butt Weld	3/4" Pipe Butt Weld		3.24" (82.34)	0.89" (22.7)	2.25" (57.1)	6.5" (165)
BK□□-TB24-25G	1 1/2" Tube Butt Weld	1 1/2" Tube Butt Weld	1 (25.4)	—	—	—	—
BK□□-TS20-25G	1 1/4" Tube Socket Weld	1 1/4" Tube Socket Weld		—	—	—	—
BK□□-PB20-25G	1 1/4" Pipe Butt Weld	1 1/4" Pipe Butt Weld		—	—	—	—
BK□□-TB32-38G	2" Tube Butt Weld	2" Tube Butt Weld	1.5 (38.1)	—	—	—	—
BK□□-PB24-38G	1 1/2" Pipe Butt Weld	1 1/2" Pipe Butt Weld		—	—	—	—
BK□□-PS24-38G	1 1/2" Pipe Socket Weld	1 1/2" Pipe Socket Weld		—	—	—	—

1. Connection type of "FITOK" means FITOK double ferrule tube fittings.
2. Sizes and types listed are standard. Other sizes and types are available upon request. For details, please contact FITOK Group or our authorized distributors.
3. Dimensions are shown with FITOK tube fitting nuts finger-tight. For dimensions not shown above, please contact FITOK Group or our authorized distributors.

Ordering Number Description

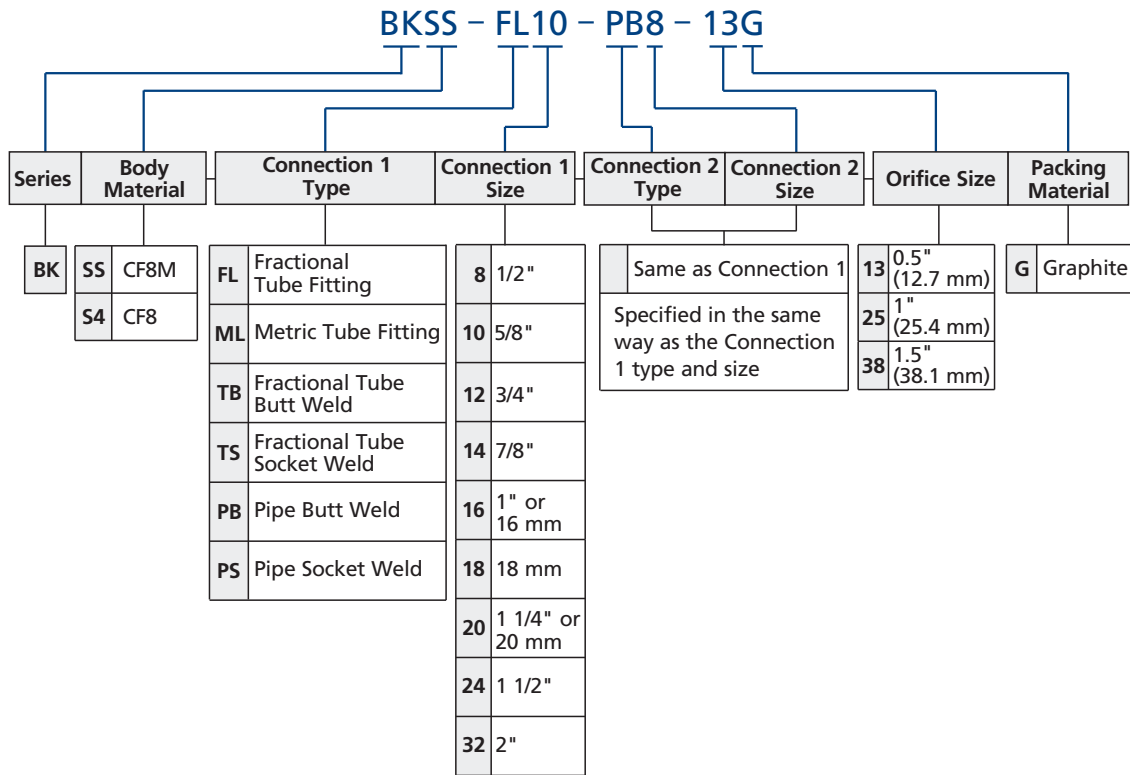

NOTE: "Ordering Number Description" is a reference to understand the combination rules of FITOK product part number. Not all combinations are available.

Alternative Fuel Service (AFS) Ball Valves

BU Series

Features

- ⦿ Working pressures up to 6000 psig (413 bar)
- ⦿ Working temperature: -40 to 250°F (-40 to 121°C)
- ⦿ High flow-Cv from 4.0 to 13.8
- ⦿ Low-temperature fluorocarbon material provides sealing capability over full temperature range
- ⦿ Spring-loaded seat provides leak-tight integrity in both low-and high-pressure systems and reduces seat wear from pressure surges
- ⦿ A variety of end connections available
- ⦿ Low operating torque
- ⦿ All wetted components are compatible with hydrogen and compressed natural gas (CNG)
- ⦿ No packing adjustment required
- ⦿ Bi-directional flow
- ⦿ Options for handle colors
- ⦿ Pneumatic actuators available
- ⦿ Each valve is leak tested with Nitrogen or compressed air at working pressure to meet a requirement of no visible leak
- ⦿ Field repairable with seal kit
- ⦿ ECE R110 type approval available

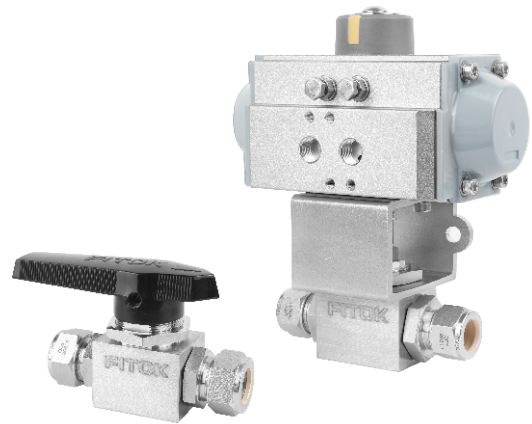

Pressure VS Temperature Ratings

End Connection	FITOK Tube Fitting			Female Pipe	
	3/8, 1/2 in., 12 mm	3/4 in., 16 mm	1 in.	3/8, 1/2 in.	3/4 in.
Temperature °F (°C)	Working Pressure, psig (bar)				
-40 (-40) ~ 250 (121)	6000 (414)	5800 (400)	4700 (324)	6000 (414)	6000 (414)

Note: Ratings are based on valves of standard materials.

Standard Materials of Construction

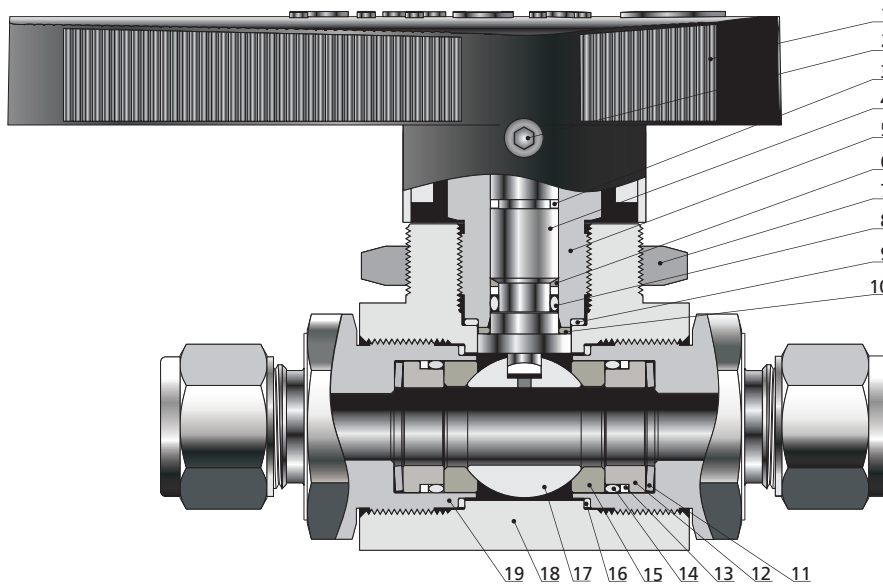

Ball Valves
Plug Valves

Item	Component	Material/ASTM Standard
1	Handle	Nylon with stainless steel insert
2	Set screw	Zinc-plated carbon steel
3	<i>Guide ring</i>	<i>PTFE/D1710</i>
4	<i>Stem</i>	<i>316 SS/A479</i>
5	<i>Packing bolt</i>	<i>316 SS/A479</i>
6	<i>Stem backup ring</i>	<i>PEEK</i>
7	<i>Lock nut</i>	<i>316 SS/A479</i>
8	<i>Stem O-ring</i>	<i>Low-temperature fluorocarbon</i>
9	<i>Packing bolt washer</i>	<i>Silver-plated 316 SS/A269</i>
10	<i>Thrust washer</i>	<i>PEEK</i>
11	<i>Coned-disc spring</i>	<i>316 SS/A240</i>
12	<i>Seat gland</i>	<i>316 SS/A479</i>
13	<i>Seat backup ring</i>	<i>PTFE/D1710</i>
14	<i>Seat O-ring</i>	<i>Low-temperature fluorocarbon</i>
15	<i>Seat</i>	<i>PEEK</i>
16	<i>End connection gasket</i>	<i>Silver-plated 316 SS/A269</i>
17	<i>Ball</i>	<i>316 SS/A479</i>
18	<i>Body</i>	<i>316 SS/A479</i>
19	<i>End connection</i>	<i>316 SS/A479</i>
	<i>Lubricant</i>	<i>PTFE-based</i>

Note: Wetted components listed in italics.

Dimensions

Dimensions in in. (mm) are for reference only and subject to change.

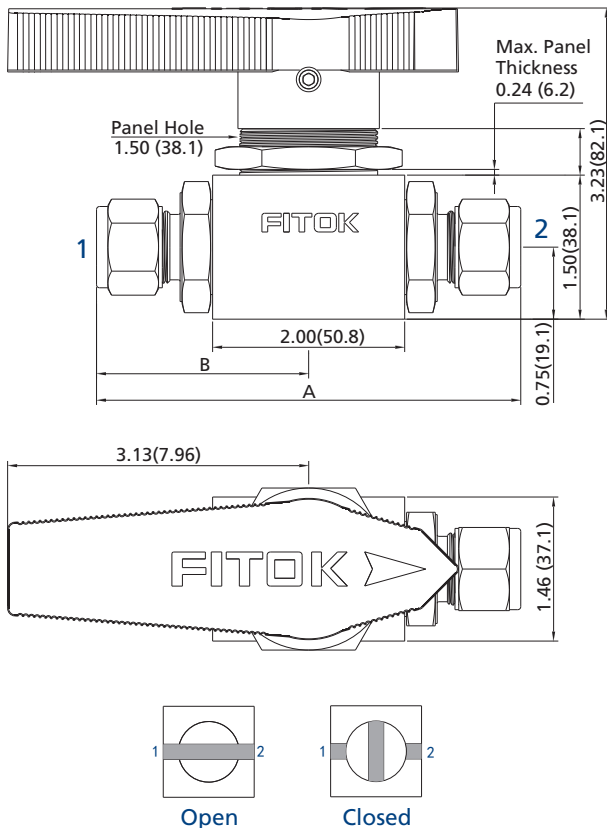

Ordering Number	Connection ^① Type and Size	Cv	Orifice in. (mm)	Dimensions in. (mm)	
				A	B
BUSS-ML10-P12	10 mm FITOK	5.2	0.31 (7.9)	4.21 (107)	2.11 (53.5)
BUSS-ML12-P12	12 mm FITOK	5.2	0.41 (10.3)	4.42 (112.2)	2.21 (56.1)
BUSS-ML16-P12	16 mm FITOK	12.4	0.47 (12.0)	4.42 (112.3)	2.21 (56.2)
BUSS-FL6-P12	3/8" FITOK	4.0	0.28 (7.1)	4.20 (106.6)	2.10 (53.3)
BUSS-FL8-P12	1/2" FITOK	7.2	0.41 (10.3)	4.40 (111.8)	2.20 (55.9)
BUSS-FL12-P12	3/4" FITOK	7.1	0.47 (12.0)	4.50 (114.3)	2.46 (62.5)
BUSS-FL16-P12 ^②	1" FITOK	6.5	0.47 (12.0)	4.93 (125.1)	2.25 (57.1)
BUSS-FNS6-P12	3/8" Female NPT	11.0	0.47 (12.0)	4.01 (102)	2.00 (50.8)
BUSS-FNS8-P12	1/2" Female NPT	13.8		4.01 (102)	2.00 (50.8)
BUSS-FNS12-P12	3/4" Female NPT	7.8		4.13 (105)	2.06 (52.3)
BUSS-FRT8-P12	1/2" Female BSPT	13.8		4.01 (102)	2.00 (50.8)

Note: Dimensions shown with FITOK tube fitting nuts finger-tight.

① Valves can be ordered with two different end connections. Contact FITOK Group or our authorized distributors.

② Not recommended for panel mounting; not available with pneumatic actuator.

CNG/NGV Application

ECE R110 Manual Service Valve Type Approval

Classification: Class 0

Temperature: -40 to 248°F (-40 to 120°C)

Pressure: 3370 psig (260 bar)

To order, add **-R110** to the valve ordering number.

Example: BUSS-ML12-P12-**R110**

Seal kit for field replacement is available, see "Seal Kits".

Seal Kits

Seal Kit Name	Seal Kit Ordering Number	Seal Kit Content
Seat seal kit	SS-BU-P-SE	Seat, seat backup ring, seat O-ring, coned-disc spring, end connection gasket, instructions.
Stem and seat seal kit	SS-BU-P	Guide ring, stem backup ring, stem O-ring, packing bolt washer, thrust washer, seat, seat backup ring, seat O-ring, coned-disc spring, end connection gasket, instructions

Ordering Number Description

BUSS – ML12 – FL12 – P12 – OSHQL – SF2

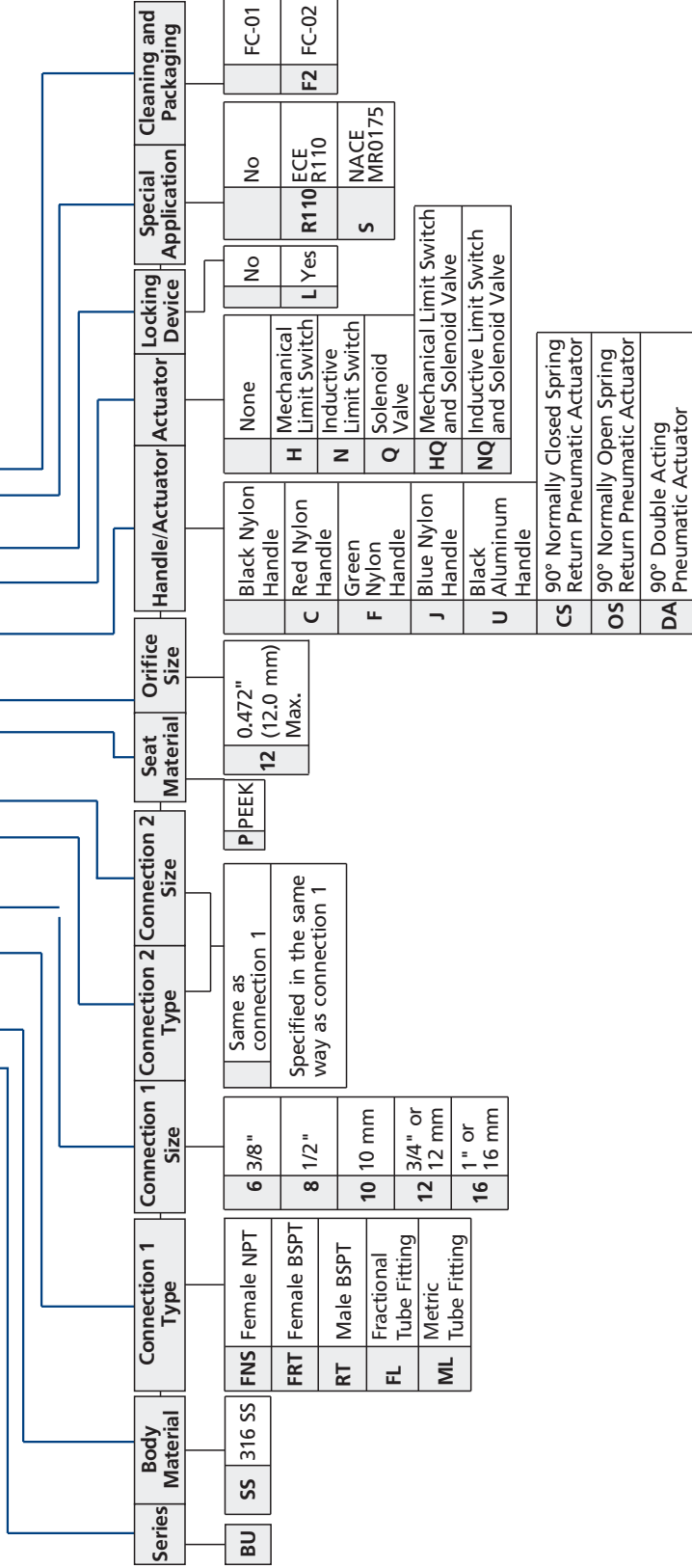

Note: "Ordering Number Description" is a reference to understand the combination rules of FITOK product part number. Not all combinations are available.

1. Standard thread pitch for metric threads are as follows:

- M10 and below: 1 mm
- M12 to M24: 1.5 mm

Standard thread pitch is omitted in ordering number.

For special thread pitch, specify in the ordering number.

2. For oxygen-enriched environment or hazardous media service, contact FITOK Group or our authorized distributors.

3. Cleaning and Packaging:

FC-01: Standard cleaning and packaging for general industrial procedures.

FC-02: Special cleaning and packaging for wetted system components to ensure compliance with product cleaning requirement of ASTM G93 Level C.

4. For more details about ball valves with pneumatic actuators, refer to Automatic Control Ball Valves.

5. Certifications do not include attachments to the valve, such as actuators or a different handle mechanism.

info@fitokgroup.com
www.fitokgroup.com

FK-IC-GV-01-EN-200515

Plug Valves

PV Series

Ball Valves
Plug Valves



Features

- ⦿ Working pressure up to: 3000 psig (207 bar)
- ⦿ Working temperature: -10°F to 400°F (-23°C to 204°C)
- ⦿ Sizes from 1/8" to 3/4" and 6 to 12 mm
- ⦿ Easy to maintain and clean
- ⦿ Low operating torque
- ⦿ Replaceable plug assembly
- ⦿ Handle as indicator of flow direction
- ⦿ Options for handle color
- ⦿ Positive handle shutoff
- ⦿ Bottom end connections as the only inlet port for 3-way valves
- ⦿ Leak-tight performance testing with nitrogen or compressed air for every valve at the maximum working pressure to meet the requirement of no visible leak

Pressure vs. Temperature

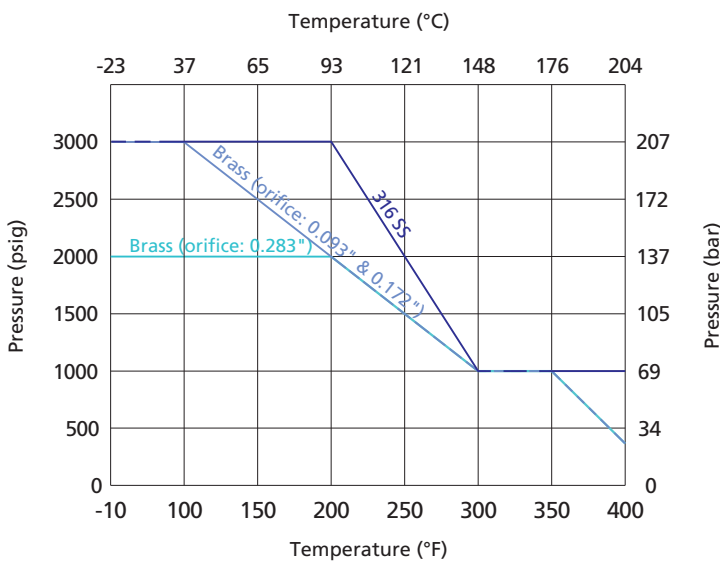

Operation (2-way)

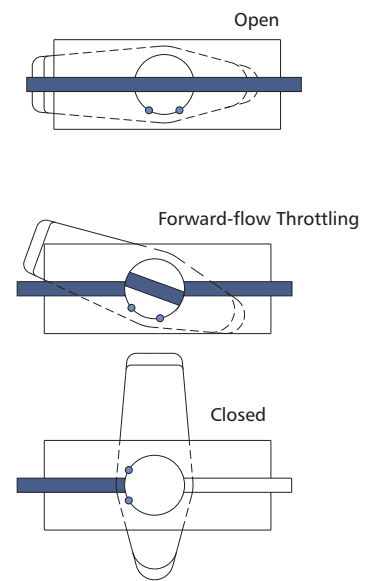

1. Differential pressure is limited to 150 psig (10.3 bar) maximum if reverse flow occurs.
2. Reverse flow throttling may damage O-ring.

Downstream Vents (2-way)

Plug and valve body allow pressure to be released to atmosphere when closed.
Maximum working pressure: 150 psig (10.3 bar).



Standard Materials of Construction

2-way

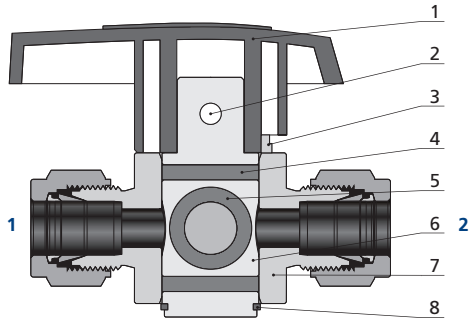

Item	Component	Material Grade/ASTM Specification	
		Valve Body Material	
		316 SS	Brass
1	Handle	Nylon or Aluminium	
2	Handle Pin	Stainless steel	
3	Body Pin	Stainless steel	
4	O-ring	Fluorocarbon FKM or Neoprene or EPDM or Buna N or Kalrez	
5	O-ring	Fluorocarbon FKM or Neoprene or EPDM or Buna N or Kalrez	
6	Plug	PTFE-coated 316 SS/A479	PTFE-coated brass/B453
7	Body	316 SS/A479	Brass/B453
8	Retaining Ring	Stainless steel	
Lubricant		Silicone-based	

3-way

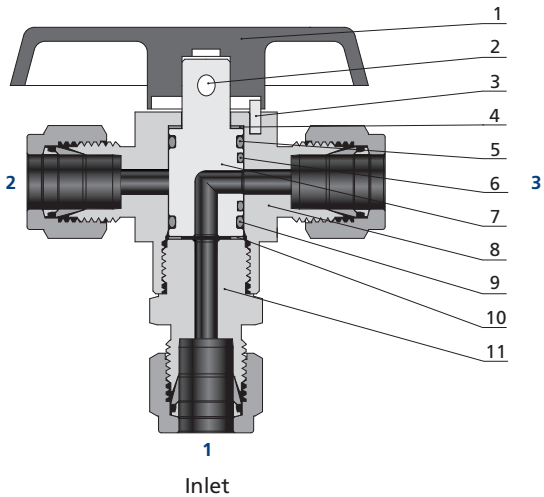

Note: The 3-way plug valve is in working state when the handle is in limit positions. There will be a short moment of interconnection for the three ports when rotating the handle.

Item	Component	Material Grade/ASTM Specifications	
		Valve Body Material	
		316 SS	Brass
1	Handle	Aluminium	
2	Handle Pin	Stainless steel	
3	Body Pin	Stainless steel	
4	Gasket	PTFE	
5	O-ring	Fluorocarbon FKM or Neoprene or EPDM or Buna N or Kalrez	
6	O-ring	Fluorocarbon FKM or Neoprene or EPDM or Buna N or Kalrez	
7	Plug	PTFE-coated 316 SS/A479	PTFE-coated brass/B453
8	Body	316 SS/A479	Brass/B453
9	O-ring	Fluorocarbon FKM or Neoprene or EPDM or Buna N or Kalrez	
10	Gasket	PTFE	
11	Fitting	316 SS/A479	Brass/B453
Lubricant		Silicone-based	

Ball Valves
Plug Valves

Dimensions

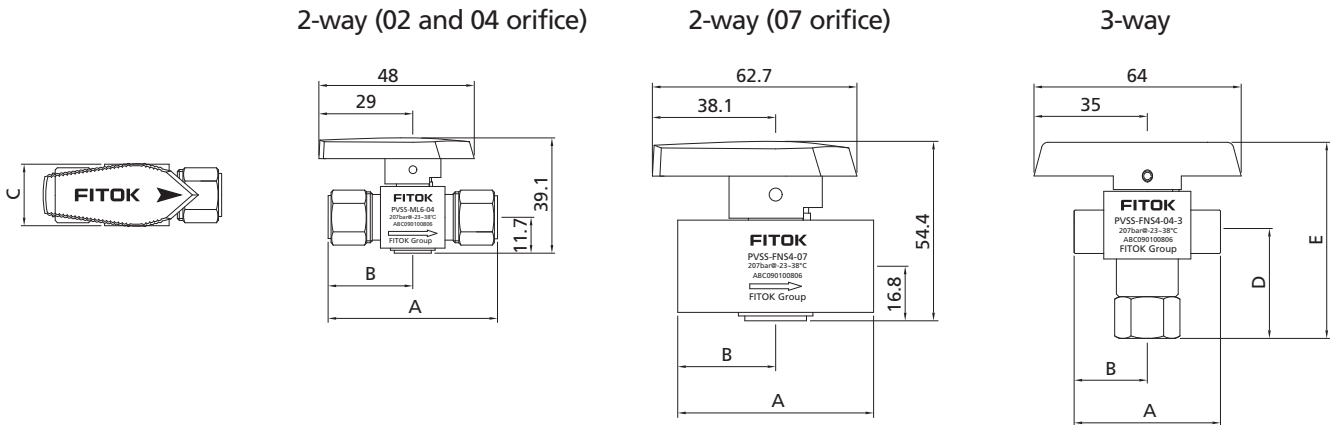

Ball Valves
Plug Valves

Basic Ordering Number		Connection Type and Size		Orifice in. (mm)	Cv	Dimensions, in. (mm)				
2-way	3-way	Inlet 1	Outlet 2/3			A	B	C	D	E
PV□□-FL2-02	PV□□-FL2-02-3	1/8" FITOK	1/8" FITOK	0.09 (2.4)	0.10	1.99 (50.5)	0.98 (24.9)	0.75 (19.0)	1.61 (40.8)	2.69 (68.4)
PV□□-FL4-04	PV□□-FL4-04-3	1/4" FITOK	1/4" FITOK	0.17 (4.4)	1.6	2.17 (55.1)	1.08 (27.4)		1.70 (43.3)	2.79 (70.9)
PV□□-FL6-04	PV□□-FL6-04-3	3/8" FITOK	3/8" FITOK		1.1	2.29 (58.2)	1.14 (29.0)		1.76 (44.8)	2.85 (72.4)
PV□□-FL6-07	PV□□-FL6-07-3	3/8" FITOK	3/8" FITOK	0.28 (7.2)	6.4	2.66 (67.6)	1.33 (33.8)	1.12 (28.5)	2.16 (54.8)	3.43 (87.2)
PV□□-FL8-07	PV□□-FL8-07-3	1/2" FITOK	1/2" FITOK		4.4	2.88 (73.2)	1.44 (36.6)		2.26 (57.3)	3.53 (89.7)
PV□□-ML3-02	PV□□-ML3-02-3	3 mm FITOK	3 mm FITOK	0.09 (2.4)	0.10	1.99 (50.5)	0.98 (24.9)	0.75 (19.0)	1.61 (40.8)	2.69 (68.4)
PV□□-ML6-04	PV□□-ML6-04-3	6 mm FITOK	6 mm FITOK	0.17 (4.4)	1.6	2.17 (55.1)	1.08 (27.4)		1.70 (43.3)	2.79 (70.9)
PV□□-ML10-07	PV□□-ML10-07-3	10 mm FITOK	10 mm FITOK		6.4	2.68 (68.1)	1.34 (34.0)		2.17 (55.1)	3.44 (87.5)
PV□□-ML12-07	PV□□-ML12-07-3	12 mm FITOK	12 mm FITOK	0.28 (7.2)	4.8	2.96 (75.2)	1.44 (36.6)	1.12 (28.5)	2.26 (57.5)	3.54 (89.9)
PV□□-FNS2-04	PV□□-FNS2-04-3	1/8 Female NPT	1/8 Female NPT		0.17 (4.4)	1.2	1.78 (45.2)		0.89 (22.6)	0.75 (19.0)
PV□□-FNS4-04	PV□□-FNS4-04-3	1/4 Female NPT	1/4 Female NPT	0.9		2.10 (53.4)	1.05 (26.7)	1.50 (38.0)	2.58 (65.6)	
PV□□-FNS4-07	PV□□-FNS4-07-3	1/4 Female NPT	1/4 Female NPT	0.28 (7.2)	4.3	2.38 (60.5)	1.19 (30.2)	1.12 (28.5)	1.89 (48.0)	3.17 (80.4)
PV□□-FNS8-07	PV□□-FNS8-07-3	1/2 Female NPT	1/2 Female NPT		2.7	2.88 (73.2)	1.44 (36.6)		2.08 (52.8)	3.35 (85.2)
PV□□-NS2-04	PV□□-NS2-04-3	1/8 Male NPT	1/8 Male NPT	0.17 (4.4)	1.0	1.53 (38.9)	0.76 (19.3)	0.75 (19.0)	1.37 (34.9)	2.46 (62.5)
PV□□-NS4-04	PV□□-NS4-04-3	1/4 Male NPT	1/4 Male NPT		1.0	1.90 (48.3)	0.95 (24.1)		1.55 (39.4)	2.64 (67.0)
PV□□-NS8-07	PV□□-NS8-07-3	1/2 Male NPT	1/2 Male NPT	0.28 (7.2)	2.4	2.64 (67.1)	1.32 (33.5)	1.12 (28.5)	2.15 (54.5)	3.42 (86.9)
PV□□-FRT2-04	PV□□-FRT2-04-3	1/8 Female BSPT	1/8 Female BSPT	0.17 (4.4)	1.2	1.78 (45.2)	0.89 (22.6)	0.75 (19.0)	1.31 (33.4)	2.40 (61.0)
PV□□-FRT4-04	PV□□-FRT4-04-3	1/4 Female BSPT	1/4 Female BSPT		0.9	2.09 (53.1)	1.11 (28.2)		1.50 (38.0)	2.58 (65.6)
PV□□-FRT4-07	PV□□-FRT4-07-3	1/4 Female BSPT	1/4 Female BSPT	0.28 (7.2)	4.3	2.38 (60.5)	1.19 (30.2)	1.12 (28.5)	1.99 (50.5)	3.26 (82.9)
PV□□-FRT8-07	PV□□-FRT8-07-3	1/2 Female BSPT	1/2 Female BSPT		2.7	2.88 (73.2)	1.57 (39.9)		2.18 (55.3)	3.45 (87.7)

1. FITOK means FITOK double ferrule tube fittings.
2. Sizes and types listed are standard. Other sizes and types are available upon request. For details, please refer to the ordering information.
3. Dimensions are shown with FITOK tube fitting nuts finger-tightened. All dimensions are for reference only and are subject to change. For dimensions not shown above, please contact FITOK Group or our authorized distributors.

Ordering Number Description

PVSS—FL8—ML12—FL8—B04GV—3SF2

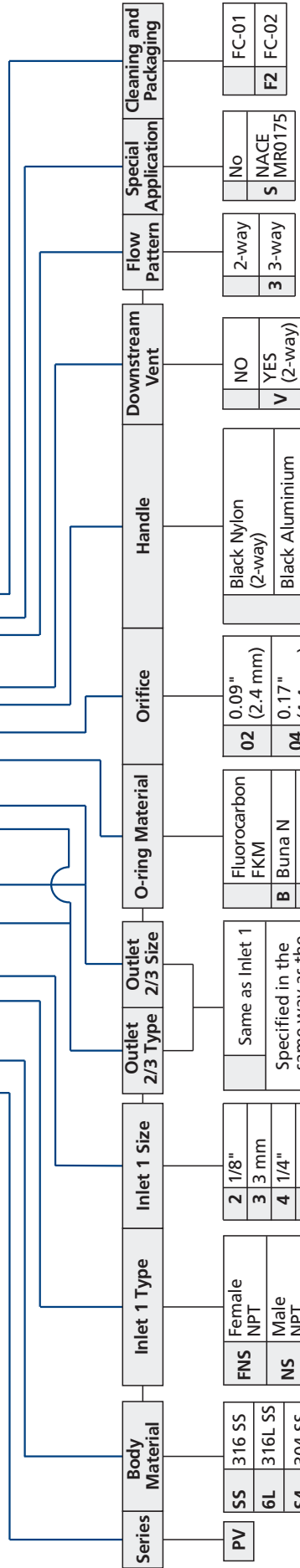

Series	Body Material	Inlet 1 Type	Inlet 1 Size	Outlet 2/3 Type	Outlet 2/3 Size	O-ring Material	Orifice	Handle	Downstream Vent	Flow Pattern	Special Application	Cleaning and Packaging
PV	SS 316 SS 6L 316L SS S4 304 SS B Brass 904L 904L SS	FNS Female NPT NS Male NPT FRT Female BSPT RT Male BSPT FMS Female Metric Thread (for RG) MS Male Metric Thread (for RG) FRP Female BSPP (for RP) BP Male BSPP (for RG) FL Fractional Tube Fitting ML Metric Tube Fitting	2 1/8" 3 3 mm 4 1/4" 6 3/8" or 6 mm 8 1/2" or 8 mm 10 10 mm 12 3/4" or 12 mm	Same as Inlet 1 Specified in the same way as the inlet 1 type and size	02 0.09" (2.4 mm) 04 0.17" (4.4 mm) 07 0.28" (7.2 mm)	Fluorocarbon FKM B Buna N E EPDM N Neoprene Z Kalrez	Black Nylon (2-way) Black Aluminium (3-way) Red Nylon (2-way) Red Aluminium (3-way) Green Nylon (2-way) Green Aluminium (3-way) Yellow Nylon (2-way) Yellow Aluminium (3-way) Blue Nylon (2-way) Blue Aluminium (3-way) Black Aluminium (2-way)	NO YES V (2-way)	2-way 3 3-way	No NACE S MR0175	FC-01 FC-02 F2	

Note: "Ordering Number Description" is a reference to understand the combination rules of FITOK product part number. Not all combinations are available.

- Standard thread pitch for metric threads are as follows:
M10 and below: 1 mm
M12 to M24: 1.5 mm
Standard thread pitch should be omitted in the ordering number, others should be specified.
- For oxygen-enriched environment or hazardous media service, please contact FITOK Group or our authorized distributors.
- Cleaning and Packaging:
FC-01: Standard cleaning and packaging for general industrial procedures.
FC-02: Special cleaning and packaging for wetted system components to ensure compliance with product cleanliness requirement of ASTM G93 Level C.

Needle Valves

NB, ND, NDH, NF, NFH, NG, NGH, NR, NRG,
NT, NU, NUH and NY Series

Needle Valves
Metering Valves



Contents

Screwed Bonnet Needle Valves

NB Series



B-72

Nonrotating-stem Needle Valves

ND Series and NDH Series



B-77

Forged Body Needle Valves

NF Series and NFH Series



B-81

Integral Bonnet Needle Valves

NG Series and NGH Series



B-87

Rising Plug Valves

NR Series and NRG Series



B-94

Toggle Valves

NT Series



B-98

Union Bonnet Needle Valves

NU Series and NUH Series



B-102

Outside Screw and Yoke (OS&Y) Needle Valves

NY Series



B-108

Screwed Bonnet Needle Valves

NB Series: Working pressure up to 6000 psig



Features

- ⦿ Cold drawn bar as body
- ⦿ Two-piece stem design: Upper stem threads cold rolled and lower stem hardened for high strength and smooth operation
- ⦿ Upper stem thread lubricant isolated from system media
- ⦿ Linear instead of rotary motion of the rising, non-rotating stem minimizes packing abrasion and reduces the friction between the seat and the tip
- ⦿ Safety back seating seal in fully open position
- ⦿ Panel mounting available
- ⦿ Steady and durable fastening of the handle by double lock-pins
- ⦿ Handles of different colors available
- ⦿ Every valve leak tested with Nitrogen or compressed air at the maximum allowable working pressure
- ⦿ Working pressure up to:
 - Stainless steel: 6000 psig (414 bar)
 - Alloy C-276: 6000 psig (414 bar)
 - Alloy 400: 5000 psig (345 bar)
 - Titanium: 3500 psig (241 bar)
 - Brass: 3000 psig (207 bar)
- ⦿ Working temperature:
 - PTFE: -65°F to 450°F (-54°C to 232°C)
 - PEEK: -65°F to 500°F (-54°C to 260°C)
 - Graphite: -65°F to 1200°F (-54°C to 649°C)

Pressure vs. Temperature

NB Series

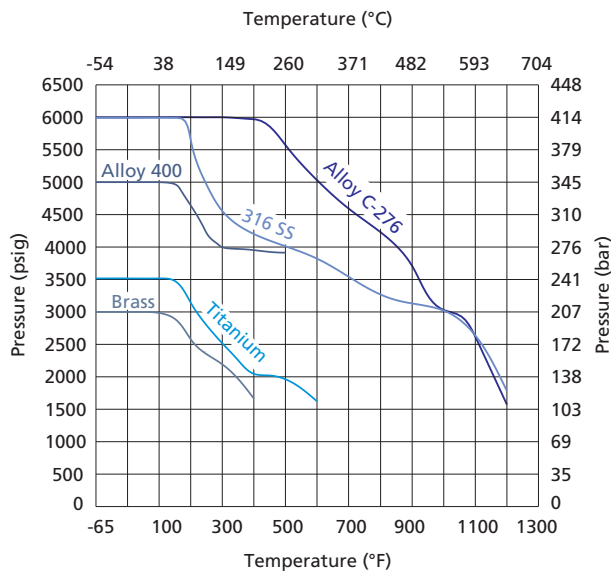

1. Graphs are based on graphite packing.
2. Temperature rating is limited to 200°F (93°C) max. with PCTFE stem tip (soft tip).
3. Contact FITOK Group or our authorized distributors for curve graph of other materials.

Flow Data at 100°F (38°C)

Regulating Stem Tip

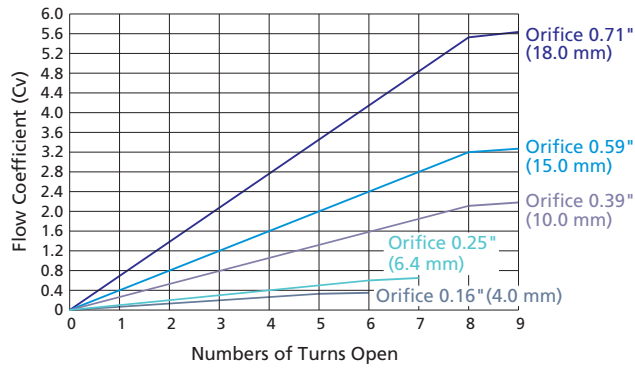

Standard Materials of Construction

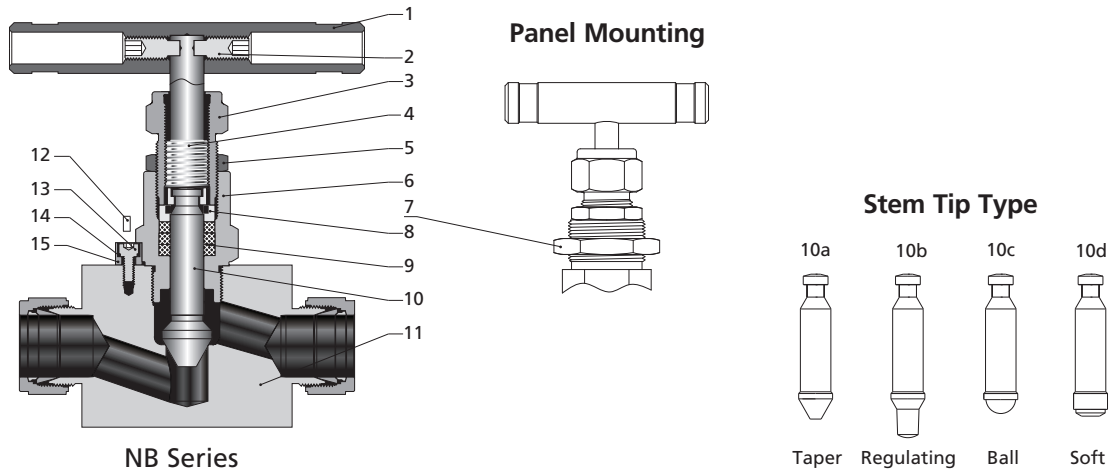

Item	Component	Valve Body Material				
		316 SS	Alloy 400	Titanium	Alloy C-276	Brass
Material Grade/ASTM Specification						
1	Handle	Anodized aluminum or stainless steel or black knob				
2	Set Screw	Galvanized carbon steel				
3	Packing Bolt	304 SS/A479				Brass C36000/B16
4	Upper Stem	316 SS/A479				
5	Lock Nut	Stainless steel				
6	Bonnet	316 SS/A479	Alloy 400/B164	Titanium Gr 4/B348	Alloy C-276/B574	Brass C36000/B16

Needle Valves
Metering Valves

Item	Component	Valve Body Material				
		316 SS	Alloy 400	Titanium	Alloy C-276	Brass
Material Grade/ASTM Specification						
7	Panel Nut	Stainless steel				Brass C36000/B16
8	Gland	316 SS/A479				
9	Packing	PTFE or PEEK or graphite				
10a 10b 10c	Lower Stem	Hardened 316 SS/A479	Alloy 400/B164	Titanium Gr 4/B348	Alloy C-276/B574	Hardened 316 SS/A479
10d	Stem	316 SS/A479	Alloy 400/B164	Titanium Gr 4/B348	Alloy C-276/B574	316 SS/A479
	Stem Tip	PTFE or PCTFE				
11	Body	316 SS/A479	Alloy 400/B164	Titanium Gr 4/B348	Alloy C-276/B574	Brass C36000/B16
	Seat	Same as Body				
12	Lock Pin	Stainless steel				
13	Screw	Stainless steel				
14	Spring Washer	Stainless steel				
15	Bush	Stainless steel				
	Lubricant	Molybdenum disulfide-based				

- Item 12 is applied in valves with orifice of 4.0 and 6.0mm. For valves with orifice of 10.0, 15.0 and 18.0mm, item 13, 14 and 15 are used instead of item 12.
- Contact FITOK Group or our authorized distributors for other materials.

Dimensions

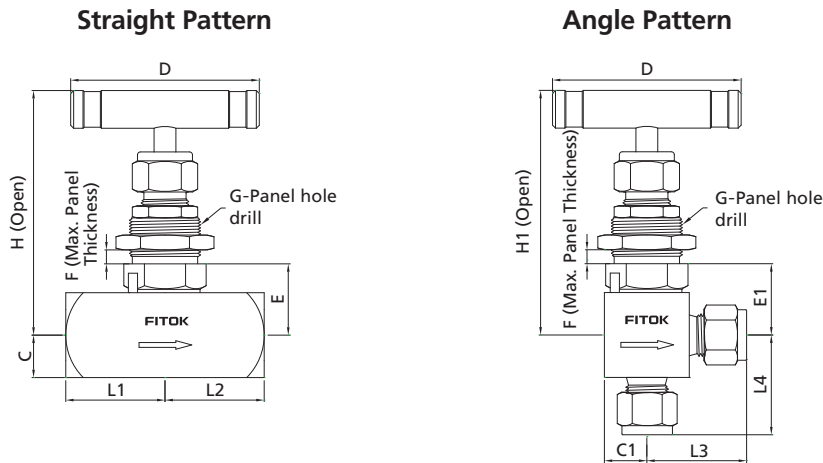

Ⓢ NB Series Needle Valves are standard without panel mounting. To order needle valves with panel mounting as illustrated, add -Y to the ordering number. Example: NBSS-FNS2-7-Y

Dimensions of NB Series

Basic Ordering Number	Connection Type and Size		Orifice in.(mm)	Cv	Dimensions, in.(mm)												
	Inlet	Outlet			L1	L2	L3	L4	C	C1	D	E	E1	F	G	H	H1
NB□□-FNS2-7	1/8 Female NPT	1/8 Female NPT	0.16 (4.0)	0.35	1.00 (25.4)	1.00 (25.4)	1.00 (25.4)	0.56 (14.3)	0.50 (12.7)	0.50 (12.7)	2.17 (55)	0.84 (21.4)	0.84 (21.4)	0.25 (6.4)	0.77 (19.6)	2.86 (72.7)	2.86 (72.7)
NB□□-FNS4-7	1/4 Female NPT	1/4 Female NPT			1.06 (26.9)	1.06 (26.9)	1.06 (26.9)	1.06 (26.9)									
NB□□-NS4-7	1/4 Male NPT	1/4 Male NPT			1.03 (26.2)	1.03 (26.2)	1.06 (26.9)	1.06 (26.9)									
NB□□-NS6-7	3/8 Male NPT	3/8 Male NPT			1.19 (30.2)	1.19 (30.2)	1.06 (26.9)	1.06 (26.9)									
NB□□-FL4-7	1/4" FITOK	1/4" FITOK			1.20 (30.5)	1.20 (30.5)	1.20 (30.5)	1.20 (30.5)									
NB□□-ML6-7	6 mm FITOK	6 mm FITOK			1.20 (30.5)	1.20 (30.5)	1.20 (30.5)	1.20 (30.5)									
NB□□-ML8-7	8 mm FITOK	8 mm FITOK			1.20 (30.5)	1.20 (30.5)	1.20 (30.5)	1.20 (30.5)									
NB□□-FNS4-8	1/4 Female NPT	1/4 Female NPT	0.25 (6.4)	0.85	1.12 (28.6)	1.12 (28.6)	1.12 (28.6)	0.63 (15.9)	0.56 (14.3)	0.56 (14.3)	2.50 (63.5)	0.89 (22.5)	0.89 (22.5)	0.38 (9.7)	0.96 (24.4)	3.50 (88.9)	3.50 (88.9)
NB□□-FNS6-8	3/8 Female NPT	3/8 Female NPT			1.12 (28.6)	1.12 (28.6)	1.12 (28.6)	1.12 (28.6)									
NB□□-NS6-8	3/8 Male NPT	3/8 Male NPT			1.41 (35.8)	1.41 (35.8)	1.32 (33.6)	1.32 (33.6)									
NB□□-FL6-8	3/8" FITOK	3/8" FITOK			1.52 (38.6)	1.52 (38.6)	1.42 (36.1)	1.42 (36.1)									
NB□□-FL8-8	1/2" FITOK	1/2" FITOK			1.52 (38.6)	1.52 (38.6)	1.42 (36.1)	1.42 (36.1)									

Dimensions of NB Series

Basic Ordering Number	Connection Type and Size		Orifice in.(mm)	Cv	Dimensions, in.(mm)																											
	Inlet	Outlet			L1	L2	L3	L4	C	C1	D	E	E1	F	G	H	H1															
NB□□-ML10-8	10 mm FITOK	10 mm FITOK	0.25 (6.4)	0.85	1.42 (36.1)	1.42 (36.1)	1.33 (33.8)	1.33 (33.8)	0.56 (14.3)	0.56 (14.3)	2.50 (63.5)	0.89 (22.5)	0.89 (22.5)	0.38 (9.7)	0.96 (24.4)	3.50 (88.9)	3.50 (88.9)															
NB□□-ML12-8	12 mm FITOK	12 mm FITOK			1.52 (38.6)	1.52 (38.6)	1.42 (36.1)	1.42 (36.1)																								
NB□□-ML14-8	14 mm FITOK	14 mm FITOK			1.56 (39.7)	1.56 (39.7)																										
NB□□-TS6-8-G	3/8" TS	3/8" TS			1.13 (28.6)	1.13 (28.6)	1.13 (28.6)	1.13 (28.6)																								
NB□□-TS8-8-G	1/2" TS	1/2" TS																														
NB□□-MTS12-8-G	12 mm MTS	12 mm MTS			0.39 (10.0)	2.18	1.97 (50.0)	1.97 (50.0)										1.61 (41.0)	1.61 (41.0)	0.88 (22.2)	0.75 (19.05)	3.50 (88.9)	1.38 (34.9)	1.25 (31.75)	0.38 (9.7)	1.08 (27.5)	4.11 (104.5)	4.11 (104.5)				
NB□□-MTS14-8-G	14 mm MTS	14 mm MTS																											1.75 (44.5)	1.75 (44.5)	1.63 (41.3)	1.50 (38.1)
NB□□-MTS16-8-G	16 mm MTS	16 mm MTS																											1.50 (38.1)	1.50 (38.1)		
NB□□-MTB14-8-G	14 mm MTB	14 mm MTB																											2.92 (74.1)	2.92 (74.1)	1.50 (38.1)	1.50 (38.1)
NB□□-MTB16-8-G	16 mm MTB	16 mm MTB																														
NB□□-UMB14-8	14 mm UMB	14 mm UMB																											1.50 (38.1)	1.50 (38.1)	1.75 (44.5)	1.75 (44.5)
NB□□-UMB16-8	16 mm UMB	16 mm UMB																														
NB□□-MS20-8	M20 x 1.5 Male Metric	M20 x 1.5 Male Metric																											1.50 (38.1)	1.50 (38.1)	1.75 (44.5)	1.75 (44.5)
NB□□-MS22-8	M22 x 1.5 Male Metric	M22 x 1.5 Male Metric																														
NB□□-FNS8-9	1/2 Female NPT	1/2 Female NPT	0.59 (15.0)	3.27					1.75 (44.5)	1.75 (44.5)	1.75 (44.5)	1.75 (44.5)	1.14 (29.0)	0.88 (22.2)	5.00 (127)	1.70 (43.2)	1.43 (36.4)												0.38 (9.7)	1.28 (32.5)	5.00 (127)	4.72 (120)
NB□□-FNS12-9	3/4 Female NPT	3/4 Female NPT			1.75 (44.5)	1.75 (44.5)	1.75 (44.5)	1.75 (44.5)																								
NB□□-NS12-9	3/4 Male NPT	3/4 Male NPT			1.50 (38.1)	1.50 (38.1)																										
NB□□-FL12-9	3/4" FITOK	3/4" FITOK			2.98 (75.7)	2.98 (75.7)	1.75 (44.5)	1.75 (44.5)																								
NB□□-ML14-9	14 mm FITOK	14 mm FITOK																														
NB□□-ML16-9	16 mm FITOK	16 mm FITOK			1.56 (39.7)	1.56 (39.7)	1.75 (44.5)	1.75 (44.5)																								
NB□□-ML18-9	18 mm FITOK	18 mm FITOK																														
NB□□-MTS14-9-G	14 mm MTS	14 mm MTS			1.75 (44.5)	1.75 (44.5)	1.75 (44.5)	1.75 (44.5)																								
NB□□-MTS16-9-G	16 mm MTS	16 mm MTS																														
NB□□-TS12-9-G	3/4" TS	3/4" TS			1.75 (44.5)	1.75 (44.5)	1.75 (44.5)	1.75 (44.5)																								
NB□□-UMB14-9	14 mm UMB	14 mm UMB																														
NB□□-MS27-9	M27 x 2 Male Metric	M27 x 2 Male Metric			1.75 (44.5)	1.75 (44.5)	1.75 (44.5)	1.75 (44.5)																								
NB□□-FNS12-6	3/4 Female NPT	3/4 Female NPT																1.14 (29.0)	1.14 (29.0)													
NB□□-TS16-6-G	1" TS	1" TS			0.71 (18.0)	5.65	1.97 (50.0)	1.97 (50.0)										1.24 (31.5)	5.00 (127)	1.24 (31.5)	5.00 (127)	1.24 (31.5)	5.00 (127)	1.24 (31.5)	5.00 (127)	1.24 (31.5)	5.00 (127)	1.24 (31.5)				
NB□□-MTS25-6-G	25 mm MTS	25 mm MTS	1.75 (44.5)	1.75 (44.5)																												
NB□□-MTS28-6-G	28 mm MTS	28 mm MTS	1.75 (44.5)	1.75 (44.5)																												
NB□□-PS12-6-G	3/4 PS	3/4 PS																														
NB□□-FNS16-0	1 Female NPT	1 Female NPT	0.71 (18.0)	5.65	1.97 (50.0)	1.97 (50.0)	1.24 (31.5)	5.00 (127)	1.24 (31.5)	5.00 (127)	1.24 (31.5)	5.00 (127)	1.24 (31.5)	5.00 (127)	1.24 (31.5)	5.00 (127)	1.24 (31.5)	5.00 (127)														
NB□□-MTS25-0-G	25 mm MTS	25 mm MTS																	1.97 (50.0)	1.97 (50.0)												
NB□□-TS16-0-G	1" TS	1" TS																	1.97 (50.0)	1.97 (50.0)												
NB□□-MTS28-0-G	28 mm MTS	28 mm MTS																	1.97 (50.0)	1.97 (50.0)												
NB□□-PS12-0-G	3/4 PS	3/4 PS																														
NB□□-PS16-0-G	1 PS	1 PS	1.97 (50.0)	1.97 (50.0)																												

1. Connection type of "FITOK" means FITOK double ferrule tube fittings. When the connection type of valves is FITOK double ferrule tube fitting, the working pressures of the valves are related to the wall thickness of tubing applied. For specific working pressure of the valves, please refer to the allowable working pressures in FITOK Catalog Tubing.
2. Connection type of "TS" means fractional tube socket weld. "MTS" means metric tube socket weld. "MTB" means metric tube butt weld. "UMB" means rotatable metric tube butt weld. "PS" means pipe socket weld.
3. Sizes and types listed are standard. Other sizes and types are available upon request. For details, please contact FITOK Group or our authorized distributors.
4. Dimensions are shown with FITOK tube fitting nuts finger-tight. All dimensions are for reference only and are subject to change. For dimensions not shown above, please contact FITOK Group or our authorized distributors.

Ordering Number Description

NBSS - FL8 - ML12 - 8WB - GYM - ASF2

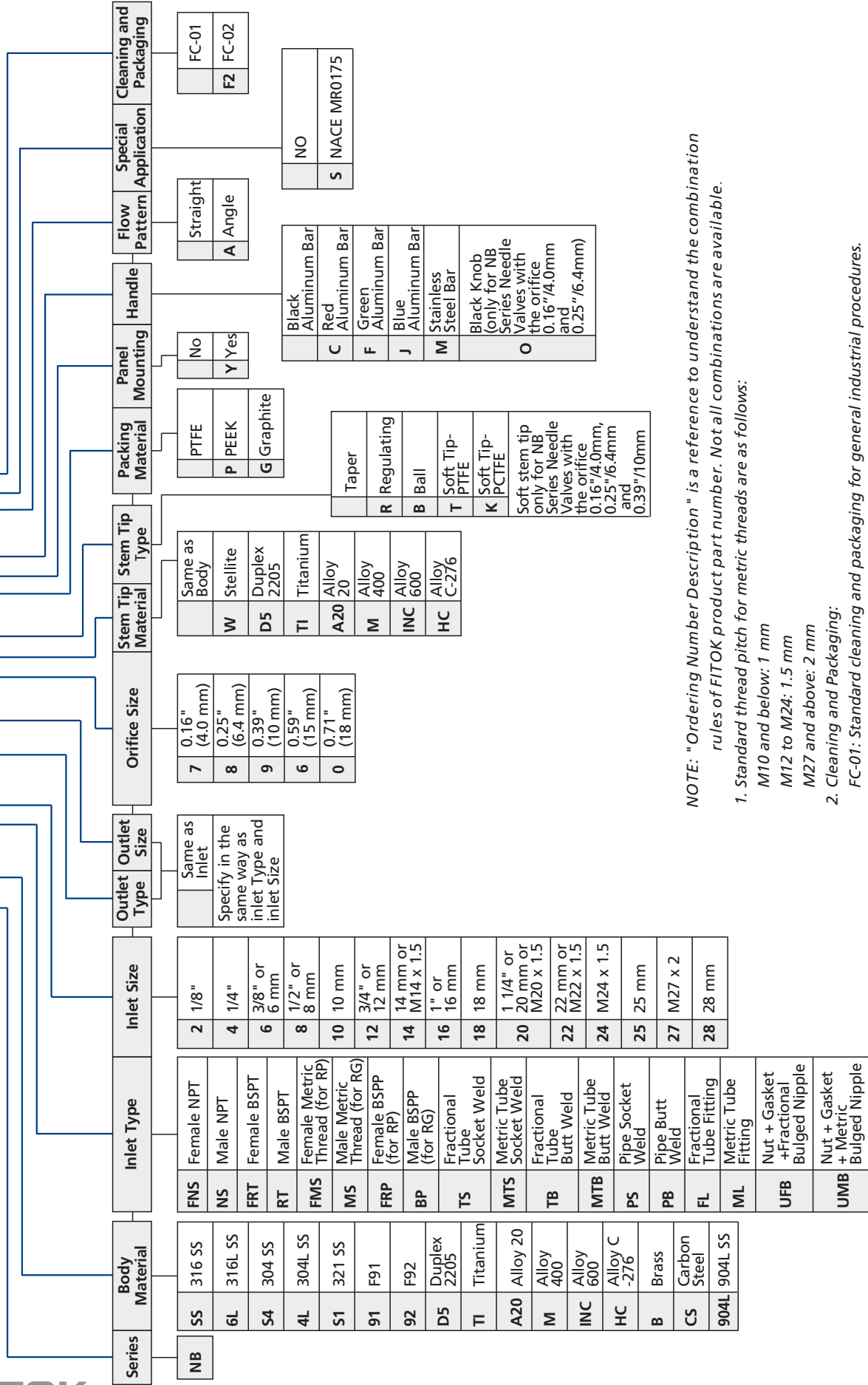

NOTE: "Ordering Number Description" is a reference to understand the combination rules of FITOK product part number. Not all combinations are available.

1. Standard thread pitch for metric threads are as follows:

- M10 and below: 1 mm
- M12 to M24: 1.5 mm
- M27 and above: 2 mm

2. Cleaning and Packaging:

- FC-01: Standard cleaning and packaging for general industrial procedures.
- FC-02: Special cleaning and packaging for wetted system components to ensure compliance with product cleanliness requirement of ASTM G93 Level C.

Nonrotating-stem Needle Valves

ND Series: Working pressure up to 3000 psig

NDH Series: Working pressure up to 5000 psig

Features

- ⦿ One-piece forged body
- ⦿ Straight and angle pattern
- ⦿ Compact design
- ⦿ Non-rotating stem
- ⦿ Specially designed handle to stop contamination from entering into the valve
- ⦿ Every valve leak tested with Nitrogen or compressed air at the maximum allowable working pressure
- ⦿ Working pressure up to:
 - ND Series—Stainless steel: 3000 psig (207 bar)
 - Brass: 3000 psig (207 bar)
 - NDH Series—Stainless steel: 5000 psig(345 bar)
- ⦿ Working temperature with stem tip:
 - PCTFE stem tip: -20°F to 200°F (-28°C to 93°C)
 - PEEK stem tip: -20°F to 400°F (-28°C to 204°C)
- ⦿ Working temperature with O-ring:
 - Fluorocarbon Rubber (FKM) : -20°F to 400°F (-28°C to 204°C)
 - Nitrile Butadiene Rubber (NBR) : -20°F to 212°F (-28°C to 100°C)
 - Ethylene Propylene Diene Rubber (EPDM): -20°F to 300°F (-28°C to 148°C)



Pressure vs. Temperature

ND Series

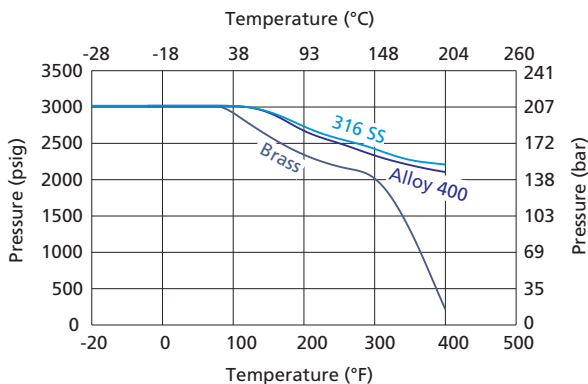

NDH Series

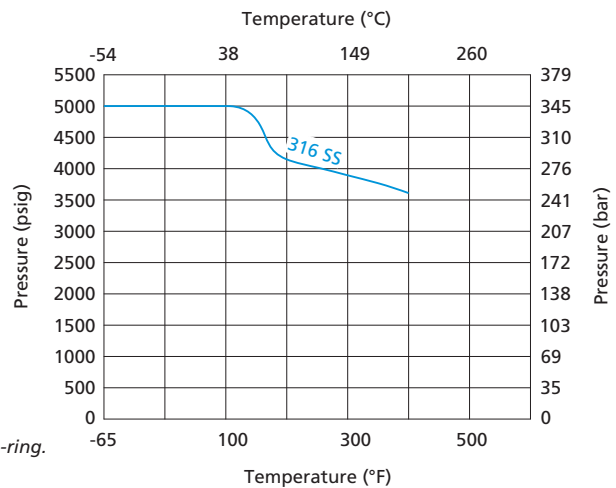

- The graphs are based on PEEK stem tip and Fluorocarbon rubber (FKM) O-ring.
- Contact FITOK Group or our authorized distributors for curve graph of other materials.

Flow Data at 100°F (38°C)

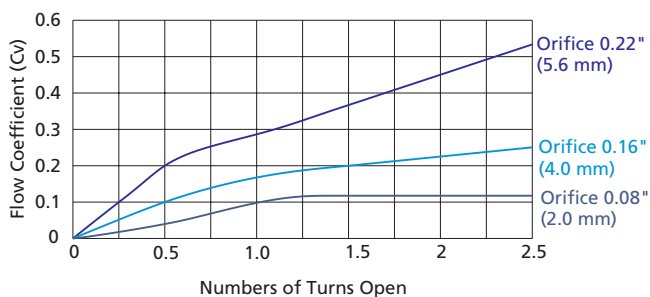

Standard Materials of Construction

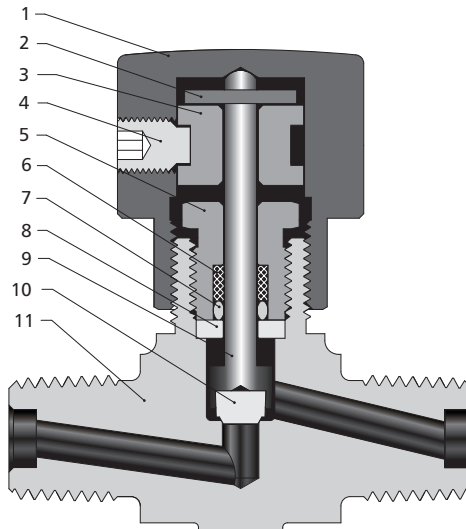

Item	Component	Valve Body Material				
		316 SS	304 SS	321 SS	Brass	Alloy 400
		Material Grade/ASTM Specification				
1	Handle	Anodized aluminum				
2	Stop Pin	Stainless steel				
3	Spool	Aluminum				
4	Set Screw	Stainless steel				
5	Packing Bolt	304 SS/A479			Brass C36000/B16	Alloy 400/B164
6	Backup Ring	PTFE/D1710				
7	O-ring	Fluorocarbon Rubber (FKM), Nitrile Butadiene Rubber (NBR) or Ethylene Propylene Diene Rubber (EPDM)				
8	Washer	316 SS/A479				Alloy 400/B164
9	Stem	316 SS/A479				Alloy 400/B164
10	Stem Tip	PCTFE or PEEK				
11	Body	316 SS/A182	304 SS/A182	321 SS/A182	Brass C37700/B283	Alloy 400/B564
	Lubricant	Molybdenum disulfide-based				

Note: Contact FITOK Group or our authorized distributors for other materials.

Dimensions

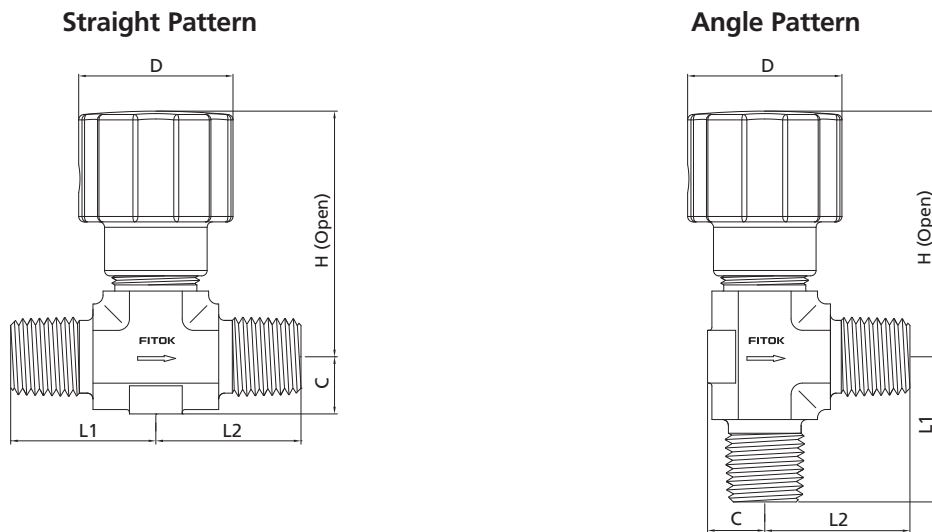

ND and NDH Series

Basic Ordering Number	Connection Type and Size		Orifice in.(mm)	Cv	Dimensions, in.(mm)				
	Inlet	Outlet			L1	L2	C	D	H
ND□□-NS2-5	1/8 Male NPT	1/8 Male NPT	0.08 (2.0)	0.12	0.81 (20.6)	0.81 (20.6)	0.32 (8.1)	1.06 (26.9)	1.86 (47.2)
ND□□-NS2-FL2-5	1/8 Male NPT	1/8" FITOK			0.81 (20.6)				
ND□□-FL2-5	1/8" FITOK	1/8" FITOK			1.10 (27.9)	1.10 (27.9)			
ND□□-ML3-5	3 mm FITOK	3 mm FITOK			1.10 (27.9)	1.10 (27.9)			
ND□□-NS4-7	1/4 Male NPT	1/4 Male NPT	0.16 (4.0)	0.27	0.98 (25.0)	0.98 (25.0)	0.39 (10.0)	1.13 (28.7)	1.86 (47.2)
ND□□-NS4-FL4-7	1/4 Male NPT	1/4 FITOK			0.98 (25.0)				
ND□□-FL4-7	1/4" FITOK	1/4" FITOK			1.13 (28.7)	1.13 (28.7)			
ND□□-ML6-7	6 mm FITOK	6 mm FITOK			1.13 (28.7)	1.13 (28.7)			
ND□□-ML8-7	8 mm FITOK	8 mm FITOK	1.18 (30.0)	1.18 (30.0)					
ND□□-FNS4-8	1/4 Female NPT	1/4 Female NPT	0.22 (5.6)	0.53	1.06 (26.9)	1.06 (26.9)	0.49 (12.5)	1.22 (31.0)	2.02 (51.3)
ND□□-NS6-8	3/8 Male NPT	3/8 Male NPT			1.12 (28.6)	1.12 (28.6)			
ND□□-FL6-8	3/8" FITOK	3/8" FITOK			1.29 (32.8)	1.29 (32.8)			
ND□□-FL8-8	1/2" FITOK	1/2" FITOK			1.40 (35.6)	1.40 (35.6)			
ND□□-ML10-8	10 mm FITOK	10 mm FITOK			1.30 (33.0)	1.30 (33.0)			
ND□□-ML12-8	12 mm FITOK	12 mm FITOK			1.40 (35.6)	1.40 (35.6)			
NDH□□-NS2-5	1/8 Male NPT	1/8 Male NPT	0.08 (2.0)	0.12	0.81 (20.6)	0.81 (20.6)	0.32 (8.1)	1.06 (26.9)	1.86 (47.2)
NDH□□-FL2-5	1/8" FITOK	1/8" FITOK			0.81 (20.6)				
NDH□□-ML3-5	3 mm FITOK	3 mm FITOK			1.10 (27.9)	1.10 (27.9)			
NDH□□-NS4-7	1/4 Male NPT	1/4 Male NPT	0.16 (4.0)	0.27	0.98 (25.0)	0.95 (25.0)	0.39 (10.0)	1.13 (28.7)	1.98 (50.2)
NDH□□-FL4-7	1/4" FITOK	1/4" FITOK			0.98 (25.0)				
NDH□□-ML6-7	6 mm FITOK	6 mm FITOK			1.13 (28.7)	1.13 (28.7)			

1. Connection type of "FITOK" means FITOK double ferrule tube fittings. When the connection type of valves is FITOK double ferrule tube fitting, the working pressures of the valves are related to the wall thickness of used applied. For specific working pressure of the valves, please refer to the allowable working pressures in FITOK Catalog Tubing.
2. Sizes and types listed are standard. Other sizes and types are available upon request. For details, please contact FITOK Group or our authorized distributors.
3. Dimensions are shown with FITOK tube fitting nuts finger-tight. All dimensions are for reference only and are subject to change. For dimensions not shown above, please contact FITOK Group or our authorized distributors.

Ordering Number Description

NDSS - FNS4 - ML8 - 7PE - ASF2

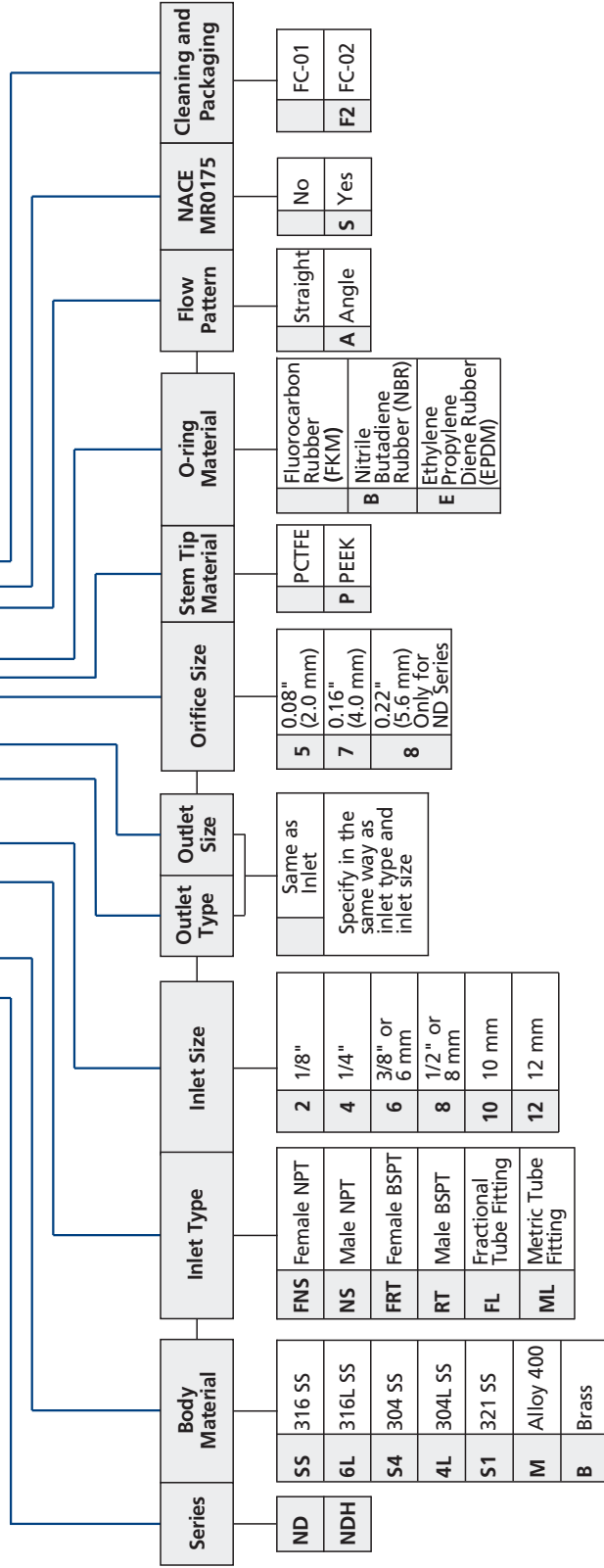

NOTE: "Ordering Number Description" is a reference to understand the combination rules of FITOK product part number. Not all combinations are available.

Cleaning and Packaging:

FC-01: Standard cleaning and packaging for general industrial procedures.

FC-02: Special cleaning and packaging for wetted system components to ensure compliance with product cleanliness requirement of ASTM G93 Level C.

Forged Body Needle Valves

NF Series: Working pressure up to 6000 psig

NFH Series: Working pressure up to 10000 psig

Features

- ⦿ One-piece forged body
- ⦿ Two-piece stem design: Upper stem threads cold rolled and lower stem hardened for high strength and smooth operation
- ⦿ Upper stem thread lubricant isolated from system media
- ⦿ Linear instead of rotary motion of the rising, non-rotating stem minimizes packing abrasion and reduces the friction between the seat and the tip
- ⦿ Panel mounting available
- ⦿ Steady and durable fastening of the handle by double lock-pins
- ⦿ Handles of different colors available
- ⦿ Every valve leak tested with Nitrogen or compressed air (NF Series) at the maximum allowable working pressure or with water (NFH Series) at 1.1 times the maximum allowable working pressure
- ⦿ Working pressure up to:
 - NF Series—Stainless steel: 6000 psig (414 bar)
 - Alloy C-276: 6000 psig (414 bar)
 - Alloy 400: 5000 psig (345 bar)
 - Titanium: 3500 psig (241 bar)
 - Brass: 3000 psig (207 bar)
- ⦿ Working temperature:
 - PTFE: -65°F to 450°F (-54°C to 232°C)
 - PEEK: -65°F to 500°F (-54°C to 260°C)
 - Graphite: -65°F to 1200°F (-54°C to 649°C)



Pressure vs. Temperature

NF Series

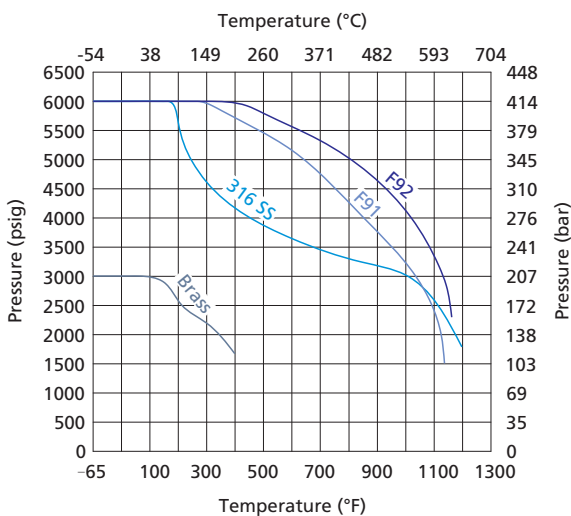

NFH Series

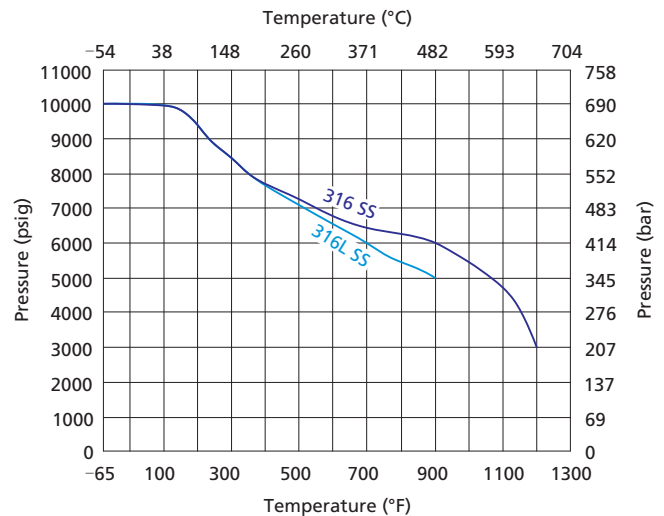

1. Graphs are based on graphite packing.
2. Soft tips are for NF Series only. Temperature rating is limited to 200°F (93°C) max. with PCTFE stem tip (soft tip).
3. Contact FITOK Group or our authorized distributors for curve graph of other materials.

Flow Data at 100°F (38°C)

Regulating Stem Tip

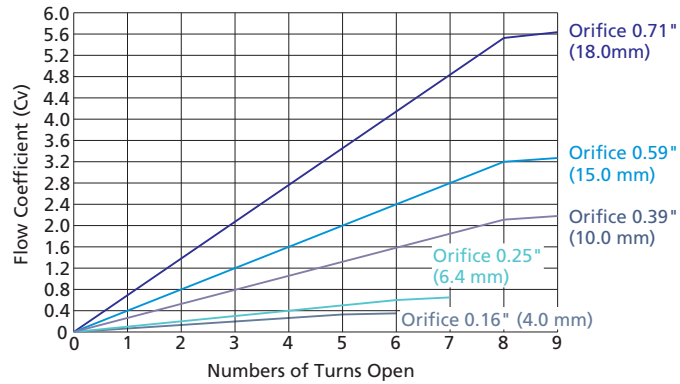

Standard Materials of Construction

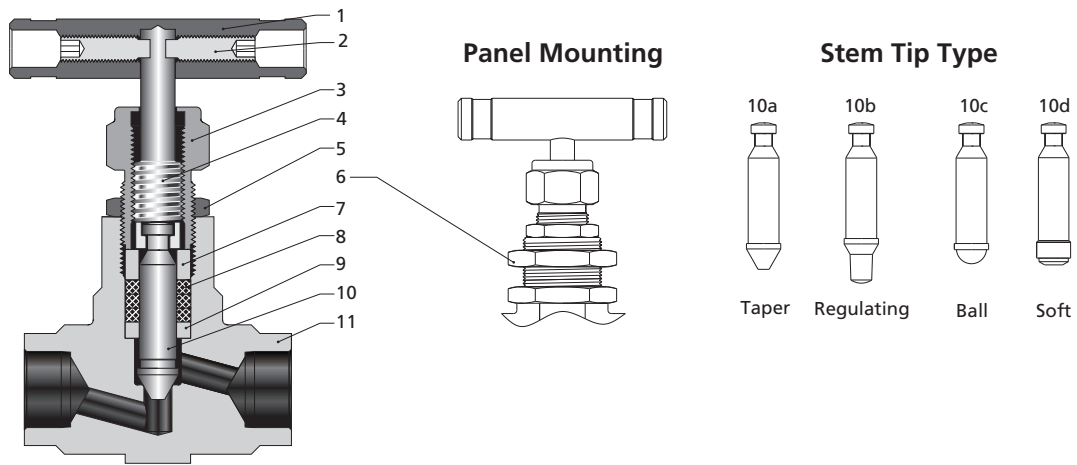

Item	Component	Valve Body Material		
		316 SS	F91	Brass
Material Grade/ASTM Specification				
1	Handle	Anodized aluminum or stainless steel or black knob		
2	Set Screw	Galvanized carbon steel		
3	Packing Bolt	304 SS/A479	F91/A182	Brass C36000/B16
4	Upper Stem	316 SS/A479		
5	Lock Nut	Stainless steel	1020/A108	Brass C36000/B16
6	Panel Nut	Stainless steel	1020/A108	Brass C36000/B16
7	Gland	316 SS/A479		Brass C36000/B16
8	Packing	PTFE or PEEK or graphite		
9	Packing Washer	316 SS/A479		Brass C36000/B16
10a 10b 10c	Lower Stem	Hardened 316 SS/A479		
10d	Stem	316 SS/A479		
	Stem Tip	PTFE or PCTFE		
11	Body	316 SS/A182	F91/A182	Brass C37700/B283
	Seat	Same as Body		
	Lubricant	Molybdenum disulfide-based		

Note: Contact FITOK Group or our authorized distributors for other materials.

Dimensions

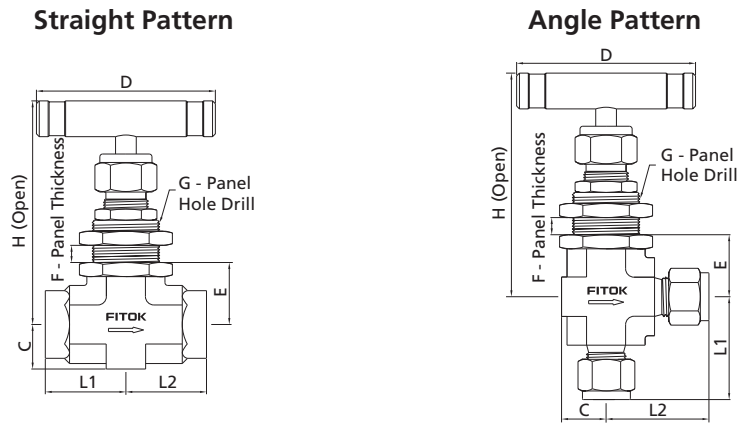

© NF Series Needle Valves are standard without panel mounting. To order needle valves with panel mounting as illustrated, add -Y to the ordering number. Example: NFSS-FNS2-7-Y

Dimensions of NF Series

Basic Ordering Number	Connection Type and Size		Orifice in.(mm)	Cv	Dimensions, in.(mm)							
	Inlet	Outlet			L1	L2	H	D	C	E	F	G
NF□□-FNS2-7	1/8 Female NPT	1/8 Female NPT	0.16 (4.0)	0.35	1.00 (25.4)	1.00 (25.4)	2.85 (72.5)	2.17 (55)	0.49 (12.5)	0.71 (18.0)	0.25 (6.4)	0.77 (19.6)
NF□□-FNS4-7	1/4 Female NPT	1/4 Female NPT			1.03 (26.2)	1.03 (26.2)						
NF□□-FL4-7	1/4" FITOK	1/4" FITOK			1.22 (30.9)	1.22 (30.9)						
NF□□-ML6-7	6 mm FITOK	6 mm FITOK			1.25 (31.75)	1.25 (31.75)						
NF□□-ML8-7	8 mm FITOK	8 mm FITOK			1.03 (26.2)	1.03 (26.2)						
NF□□-NS4-7	1/4 Male NPT	1/4 Male NPT			1.13 (28.6)	1.13 (28.6)						
NF□□-NS6-7	3/8 Male NPT	3/8 Male NPT										
NF□□-FO4-7	1/4" Male FO	1/4" Male FO										
NF□□-FR4-7	1/4" Male FR	1/4" Male FR										
NF□□-FNS4-8	1/4 Female NPT	1/4 Female NPT			0.25 (6.4)	0.85						
NF□□-FNS6-8	3/8 Female NPT	3/8 Female NPT	1.42 (36.1)	1.42 (36.1)								
NF□□-NS6-8	3/8 Male NPT	3/8 Male NPT	1.44 (36.5)	1.44 (36.5)								
NF□□-FL6-8	3/8" FITOK	3/8" FITOK	1.53 (38.9)	1.53 (38.9)								
NF□□-ML10-8	10 mm FITOK	10 mm FITOK	1.56 (39.7)	1.56 (39.7)								
NF□□-ML12-8	12 mm FITOK	12 mm FITOK	1.26 (32.0)	1.26 (32.0)								
NF□□-ML14-8	14 mm FITOK	14 mm FITOK	0.76 (19.4)									
NF□□-FNS8-8	1/2 Female NPT	1/2 Female NPT	1.50 (38.1)	1.50 (38.1)								
NF□□-NS8-8	1/2 Male NPT	1/2 Male NPT	1.53 (38.9)	1.53 (38.9)								
NF□□-FL8-8	1/2" FITOK	1/2" FITOK										
NF□□-TS6-8-G	3/8" TS	3/8" TS	0.25 (6.4)	0.85	1.13 (28.6)	1.13 (28.6)	3.38 (85.8)	2.50 (63.5)	0.62 (15.8)	0.87 (22.0)	0.38 (9.7)	0.96 (24.4)
NF□□-TS8-8-G	1/2" TS	1/2" TS			1.13 (28.6)	1.13 (28.6)						
NF□□-MTS12-8-G	12 mm MTS	12 mm MTS			1.50 (38.1)	1.50 (38.1)						
NF□□-MTS14-8-G	14 mm MTS	14 mm MTS			2.92 (74.1)	2.92 (74.1)						
NF□□-MTS16-8-G	16 mm MTS	16 mm MTS			1.13 (28.6)	1.13 (28.6)						
NF□□-MTB14-8-G	14 mm MTB	14 mm MTB			1.50 (38.1)	1.50 (38.1)						
NF□□-MTB16-8-G	16 mm MTB	16 mm MTB										
NF□□-UMB14-8	14 mm UMB	14 mm UMB										
NF□□-UMB16-8	16 mm UMB	16 mm UMB										
NF□□-FO8-8	1/2" Male FO	1/2" Male FO			1.56 (39.7)	1.56 (39.7)						
NF□□-FR8-8	1/2" Male FR	1/2" Male FR	1.50 (38.1)	1.50 (38.1)								
NF□□-MS20-8	M20 x 1.5 Male Metric	M20 x 1.5 Male Metric										

Dimensions of NF Series

Basic Ordering Number	Connection Type and Size		Orifice in.(mm)	Cv	Dimensions, in.(mm)													
	Inlet	Outlet			L1	L2	H	D	C	E	F	G						
NF□□-MS22-8	M22 x 1.5 Male Metric	M22 x 1.5 Male Metric	0.25 (6.4)	0.85	1.50 (38.1)	1.50 (38.1)	3.38 (85.8)	2.50 (63.5)	0.62 (15.8)	0.87 (22.0)	0.38 (9.7)	0.96 (24.4)						
NF□□-FNS8-9	1/2 Female NPT	1/2 Female NPT	0.39 (10.0)	2.18	1.56 (39.7)	1.56 (39.7)	3.86 (98.0)	3.50 (88.9)	0.80 (20.4)	1.10 (28.3)	0.38 (9.7)	1.08 (27.5)						
NF□□-NS12-9	3/4 Male NPT	3/4 Male NPT																
NF□□-FL12-9	3/4" FITOK	3/4" FITOK																
NF□□-ML14-9	14 mm FITOK	14 mm FITOK																
NF□□-ML16-9	16 mm FITOK	16 mm FITOK																
NF□□-ML18-9	18 mm FITOK	18 mm FITOK																
NF□□-ML20-9	20 mm FITOK	20 mm FITOK																
NF□□-MTS14-9-G	14 mm MTS	14 mm MTS																
NF□□-MTS16-9-G	16 mm MTS	16 mm MTS																
NF□□-MTS18-9-G	18 mm MTS	18 mm MTS																
NF□□-TS12-9-G	3/4" TS	3/4" TS																
NF□□-PS8-9-G	1/2 PS	1/2 PS																
NF□□-MTB16-9-G	16 mm MTB	16 mm MTB																
NF□□-UMB14-9	14 mm UMB	14 mm UMB																
NF□□-UMB16-9	16 mm UMB	16 mm UMB																
NF□□-MS27-9	M27 x 2 Male Metric	M27 x 2 Male Metric							1.56 (39.7)				1.56 (39.7)	5.00 (127)	5.00 (127)	1.08 (27.5)	1.61 (41.0)	0.38 (9.7)
NF□□-FNS12-6	3/4 Female NPT	3/4 Female NPT																
NF□□-TS16-6-G	1" TS	1" TS																
NF□□-MTS25-6-G	25 mm MTS	25 mm MTS																
NF□□-MTS28-6-G	28 mm MTS	28 mm MTS																
NF□□-PS12-6-G	3/4 PS	3/4 PS																
NF□□-PB12-6-G	3/4 PB	3/4 PB																
NF□□-FL12-6	3/4" FITOK	3/4" FITOK																
NF□□-ML20-6	20 mm FITOK	20 mm FITOK																
NF□□-TS16-0-G	1" TS	1" TS	0.71 (18.0)	5.65	1.97 (50.0)	1.97 (50.0)	5.33 (135.4)	5.00 (127)	1.08 (27.5)	1.61 (41.0)	0.38 (9.7)	1.45 (36.8)						
NF□□-MTS25-0-G	25 mm MTS	25 mm MTS																
NF□□-MTS28-0-G	28 mm MTS	28 mm MTS																
NF□□-PS12-0-G	3/4 PS	3/4 PS																
NF□□-PB16-0-G	1 PB	1 PB																

1. Connection type of "FITOK" means FITOK double ferrule tube fittings. When the connection type of valves is FITOK double ferrule tube fitting, the working pressures of the valves are related to the wall thickness of tubing applied. For specific working pressure of the valves, please refer to the allowable working pressures in FITOK Catalog Tubing.
2. Connection type of "FO" means O-ring face seal fittings. "FR" means metal gasket face seal fittings. "TS" means fractional tube socket weld. "MTS" means metric tube socket weld. "MTB" means metric tube butt weld. "UMB" means rotatable metric tube butt weld. "PS" means pipe socket weld. "PB" means pipe butt weld.
3. Sizes and types listed are standard. Other sizes and types are available upon request. For details, please contact FITOK Group or our authorized distributors.
4. Dimensions are shown with FITOK tube fitting nuts finger-tight. All dimensions are for reference only and are subject to change. For dimensions not shown above, please contact FITOK Group or our authorized distributors.

Straight Pattern

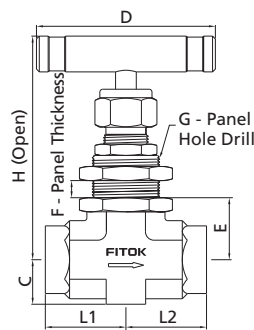

Angle Pattern

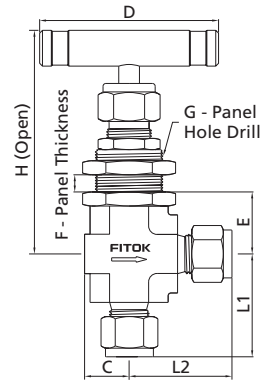

© NFH Series Needle Valves are standard without panel mounting. To order needle valves with panel mounting as illustrated, add -Y to the ordering number. Example: NFH55-FNS2-7-Y

Dimensions of NFH Series

Basic Ordering Number	Connection Type and Size		Orifice in.(mm)	Cv	Dimensions, in.(mm)							
	Inlet	Outlet			L1	L2	H	D	C	E	F	G
NFH□□-FL4-7	1/4" FITOK	1/4" FITOK	0.16 (4.0)	0.35	1.41 (35.8)	1.41 (35.8)	2.85 (72.5)	2.17 (55)	0.62 (15.8)	0.76 (19.4)	0.25 (6.4)	0.77 (19.6)
NFH□□-FNS2-7	1/8 Female NPT	1/8 Female NPT			1.00 (25.4)	1.00 (25.4)						
NFH□□-FNS4-7	1/4 Female NPT	1/4 Female NPT			1.06 (26.2)	1.06 (26.2)						
NFH□□-NS4-7	1/4 Male NPT	1/4 Male NPT			1.22 (30.9)	1.22 (30.9)						
NFH□□-FNS4-NS4-7	1/4 Female NPT	1/4 Male NPT			1.06 (26.2)	1.22 (30.9)						
NFH□□-TS4-7-G	1/4" TS	1/4" TS			1.06 (26.2)	1.06 (26.2)						
NFH□□-FNS4-8	1/4 Female NPT	1/4 Female NPT	0.25 (6.4)	0.85	1.12 (28.6)	1.12 (28.6)	3.38 (85.8)	2.50 (63.5)	0.76 (19.4)	0.87 (22.0)	0.38 (9.7)	0.96 (24.4)
NFH□□-FNS6-8	3/8 Female NPT	3/8 Female NPT			1.50 (38.1)	1.50 (38.1)						
NFH□□-NS6-8	3/8 Male NPT	3/8 Male NPT										
NFH□□-TS8-9-G	1/2" TS	1/2" TS	0.39 (10.0)	2.18	1.56 (39.7)	1.56 (39.7)	3.86 (98.0)	3.50 (88.9)	0.76 (19.4)	1.10 (28.3)	0.38 (9.7)	1.08 (27.5)
NFH□□-MTS16-9-G	16 mm MTS	16 mm MTS							0.80 (20.4)			
NFH□□-MTB25-9-G	25 mm MTB	25 mm MTB										
NFH□□-FNS8-9	1/2 Female NPT	1/2 Female NPT							4.16 (105.7)			

1. Connection type of "FITOK" means FITOK double ferrule tube fittings. When the connection type of valves is FITOK double ferrule tube fitting, the working pressures of the valves are related to the wall thickness of tubing applied. For specific working pressure of the valves, please refer to the allowable working pressures in FITOK Tubing catalog.
2. Connection type of "TS" means fractional tube socket weld. "MTS" means metric tube socket weld. "MTB" means metric tube butt weld. "
3. Sizes and types listed are standard. Other sizes and types are available upon request. For details, please contact FITOK Group or our authorized distributors.
4. Dimensions are shown with FITOK tube fitting nuts finger-tight. All dimensions are for reference only and are subject to change. For dimensions not shown above, please contact FITOK Group or our authorized distributors.

Ordering Number Description

NFS4 - TS16 - MTS25 - 6WR - GYM - ASF2 - ASF2

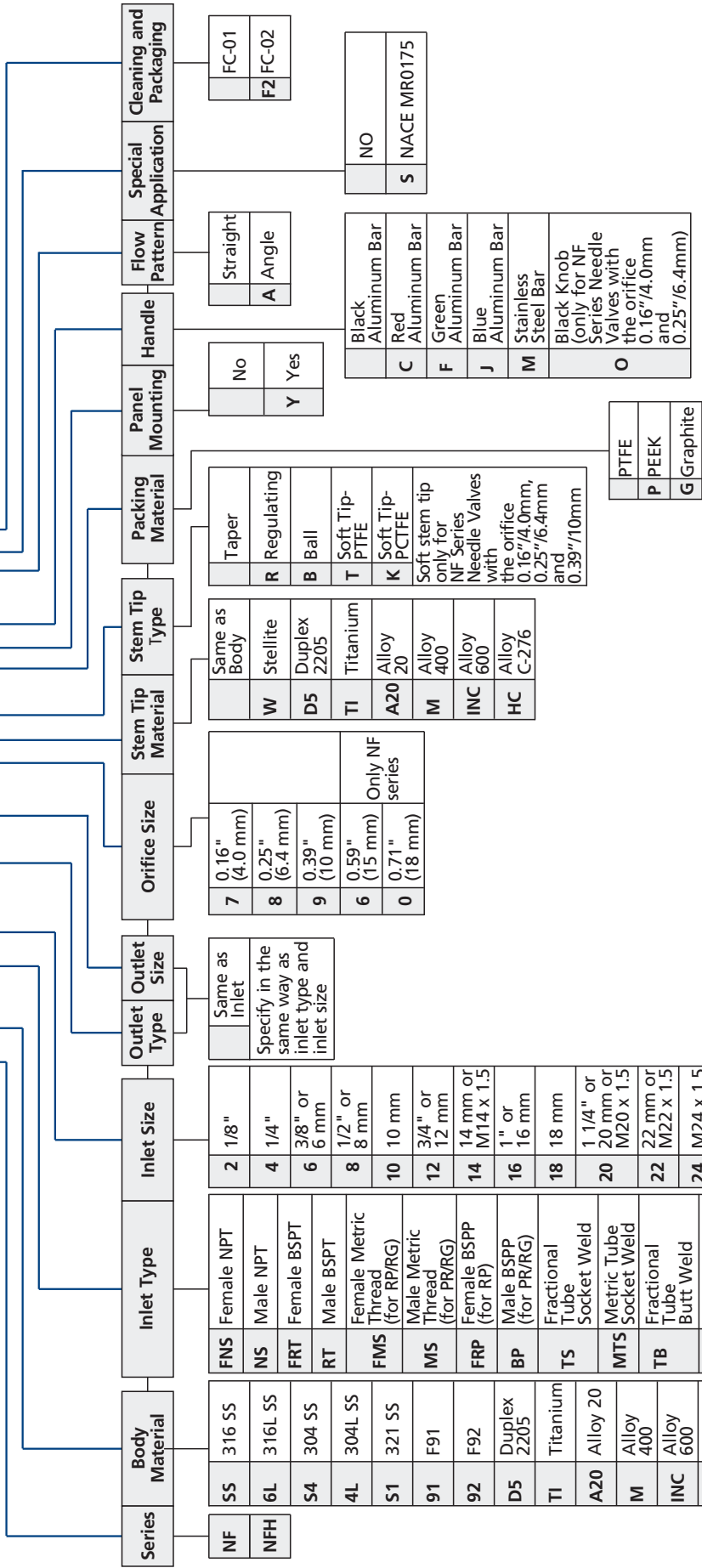

Series	Body Material	Inlet Type	Inlet Size	Outlet Type	Outlet Size	Orifice Size	Stem Tip Material	Stem Tip Type	Packing Material	Panel Mounting	Handle	Flow Pattern Application	Special Application	Cleaning and Packaging
NF	316 SS	Female NPT	2 1/8"	Same as Inlet	7 0.16" (4.0 mm)	Same as Body	W	Same as Body	Taper	No	Black Aluminum Bar	Straight	NO	FC-01
NFH	316L SS	Male NPT	4 1/4"	Specify in the same way as inlet type and inlet size	8 0.25" (6.4 mm)	Stellite	D5	Duplex 2205	Regulating	Yes	Red Aluminum Bar	Angle	S	F2 FC-02
S4	304 SS	Female BSPT	6 3/8" or 6 mm		9 0.39" (10 mm)	Ti	Alloy 20	Titanium	Ball		Green Aluminum Bar			
4L	304L SS	Male BSPT	8 1/2" or 8 mm		6 0.59" (15 mm)	Alloy 400	M	Alloy 400	Soft Tip-PTFE		Blue Aluminum Bar			
S1	321 SS	Female Metric Thread (for RP/RG)	10 10 mm		0 0.71" (18 mm)	Alloy 600	INC	Alloy 600	Soft Tip-PTFE		Stainless Steel Bar			
91	F91	Male Metric Thread (for RP/RG)	12 3/4" or 12 mm			Alloy C-276	HC	Alloy C-276	Soft stem tip only for NF Series Needle Valves with the orifice 0.16"/4.0mm, 0.25"/6.4mm and 0.39"/10mm		Black Knob (only for NF Series Needle Valves with the orifice 0.16"/4.0mm and 0.25"/6.4mm)			
92	F92	Female BSPP Thread (for RP)	14 14 mm or M14 x 1.5											
D5	Duplex 2205	Male BSPP Thread (for RP/RG)	16 1" or 16 mm											
TI	Titanium	Fractional Tube Socket Weld	18 18 mm											
A20	Alloy 20	Metric Tube Socket Weld	20 1 1/4" or 20 mm or M20 x 1.5											
M	Alloy 400	Fractional Tube Butt Weld	22 22 mm or M22 x 1.5											
INC	Alloy 600	Metric Tube Butt Weld	24 M24 x 1.5											
HC	Alloy C-276	Pipe Socket Weld	25 25 mm											
B	Brass	Pipe Butt Weld	27 M27 x 2											
CS	Carbon Steel	Fractional Tube Fitting	28 28 mm											
904L	904L SS	Metric Tube Fitting												
ML		Nut + Gasket + Fractional Bulged Nipple												
UFB		Nut + Gasket + Metric Bulged Nipple												
UMB		Male FO Fitting												
FO		Male FR Fitting												
FR														

NOTE: "Ordering Number Description" is a reference to understand the combination rules of FITOK product part number. Not all combinations are available.

- Standard thread pitch for metric threads are as follows:
 M10 and below: 1 mm
 M12 to M24: 1.5 mm
 M27 and above: 2 mm
- FO means FITOK O-ring face seal fittings.
- FR means FITOK metal gasket face seal fittings.
- Cleaning and Packaging:
 FC-01: Standard cleaning and packaging for general industrial procedures.
 FC-02: Special cleaning and packaging for wetted system components to ensure compliance with product cleanliness requirement of ASTM G93 Level C.

Integral Bonnet Needle Valves

NG Series: Working pressure up to 3000 psig

NGH Series: Working pressure up to 5000 psig

Features

- ⦿ One-piece forged body
- ⦿ Easy external adjustments by packing nut
- ⦿ Live-loaded packing system
- ⦿ Handles of different colors available
- ⦿ Compact design
- ⦿ Panel mounting available
- ⦿ Every valve leak tested with Nitrogen or compressed air at the maximum allowable working pressure
- ⦿ Working pressure up to:
 - NG Series—Stainless steel, Brass, Alloy 400: 3000 psig (207 bar)
 - NGH Series—Stainless steel: 5000 psig (345 bar)
- ⦿ Working temperature:
 - PTFE: -65°F to 450°F (-54°C to 232°C)
 - PEEK: -65°F to 500°F (-54°C to 260°C)



Pressure vs. Temperature

NG Series

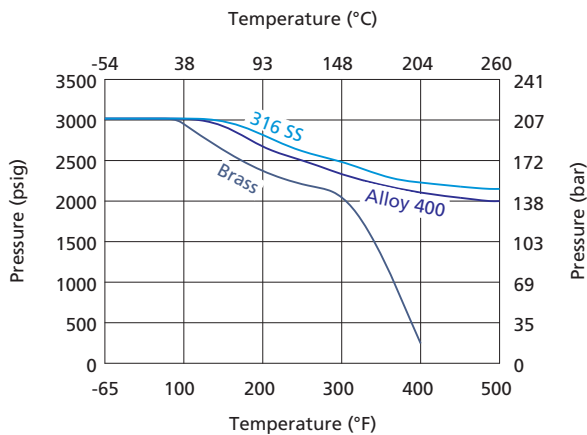

NGH Series

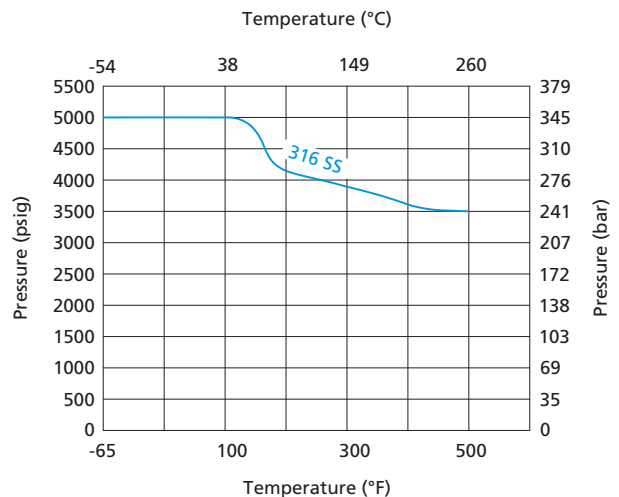

1. Graphs are based on PEEK packing.
2. Temperature rating is limited to 200°F (93°C) max with PCTFE stem tip (soft tip).
3. Contact FITOK Group or our authorized distributors for curve graph of other materials.

Flow Data at 100°F (38°C)

Regulating Stem Tip

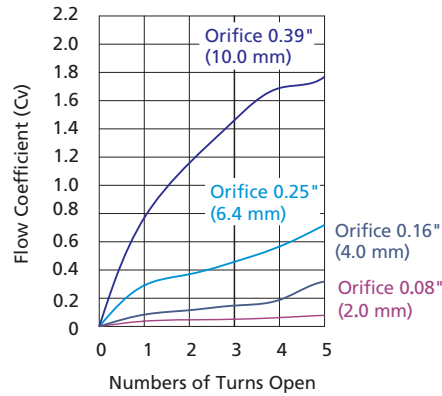

Standard Materials of Construction

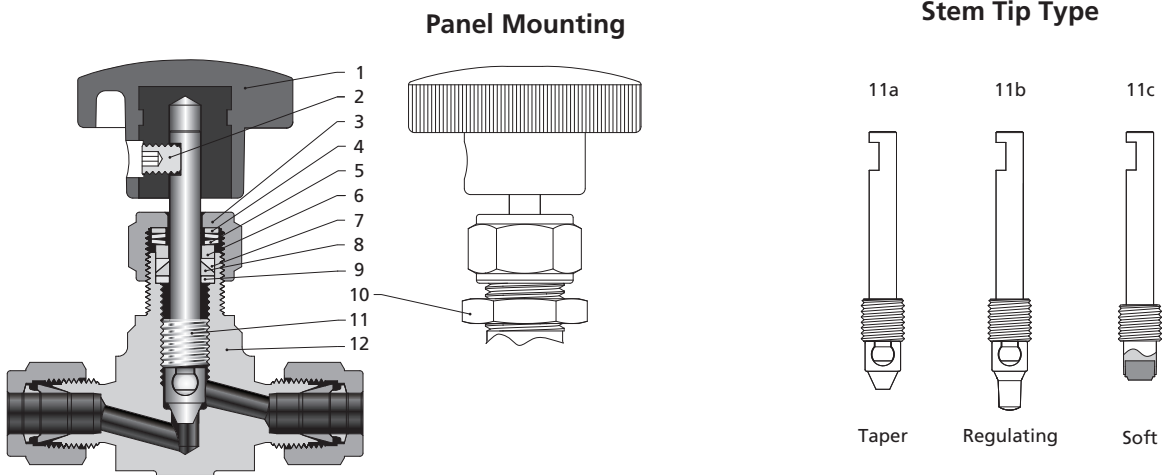

Item	Component	Valve Body Material		
		316 SS	Brass	Alloy 400
		Material Grade/ASTM Specification		
1	Handle	Black knob (aluminum or nylon with copper insert), aluminum alloy or stainless steel bar handle		
2	Set Screw	Galvanized carbon steel		
3	Packing Bolt	304 SS/A479	Brass C36000/B16	304 SS/A479
4	Washer	316 SS/A479		
5	Packing Spring	S17700/A693		
6	Washer	316 SS/A479		
7	Upper Packing	PTFE/PEEK		
8	Lower Packing			
9	Packing Washer	316 SS/A479	Alloy 400/B164	
10	Panel Nut	Stainless steel	Brass C36000/B16	Stainless steel
11a	Stem	316 SS/A479		Alloy 400/B164
11b	Stem Tip	Hardened 316 SS/A479		Alloy 400/B164
11c	Stem	316 SS/A479		Alloy 400/B164
	Stem Tip	PCTFE or PEEK		
12	Body	316 SS/A182	Brass C37700/B283	Alloy 400/B564
Lubricant		Molybdenum disulfide-based		

Note: Contact FITOK Group or our authorized distributors for other materials.

Dimensions

Straight Pattern

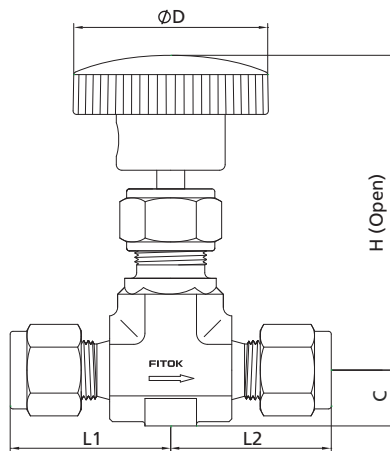

Angle Pattern

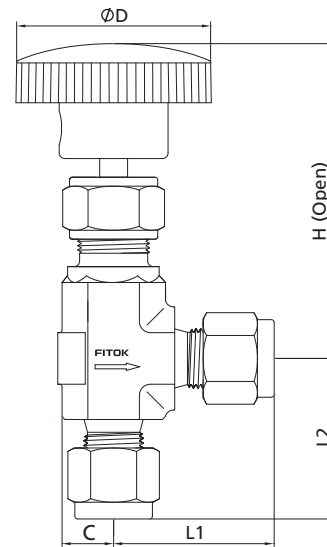

Dimensions of NG Series

Basic Ordering Number	Connection Type and Size		Orifice in.(mm)	Cv	Dimensions, in.(mm)				
	Inlet	Outlet			L1	L2	C	D	H
NG□□-NS2-5	1/8 Male NPT	1/8 Male NPT	0.08 (2.0)	0.09	0.75 (19.05)	0.75 (19.05)	0.32 (8.2)	1.00 (25.4)	2.30 (58.4)
NG□□-FNS2-5	1/8 Female NPT	1/8 Female NPT			0.81 (20.6)	0.81 (20.6)			
NG□□-FL2-5	1/8" FITOK	1/8" FITOK			0.98 (25.0)	0.98 (25.0)			
NG□□-ML3-5	3 mm FITOK	3 mm FITOK							
NG□□-FNS2-7	1/8 Female NPT	1/8 Female NPT	0.16 (4.0)	0.35	0.81 (20.6)	0.81 (20.6)	0.39 (10.0)	1.38 (35.0)	2.46 (62.5)
NG□□-NS4-7	1/4 Male NPT	1/4 Male NPT			0.98 (25.0)	0.98 (25.0)			
NG□□-FL4-7	1/4" FITOK	1/4" FITOK			1.13 (28.7)	1.13 (28.7)			
NG□□-ML6-7	6 mm FITOK	6 mm FITOK			1.17 (29.7)	1.17 (29.7)			
NG□□-ML8-7	8 mm FITOK	8 mm FITOK			2.24 (57.0)	2.24 (57.0)			
NG□□-UMB6-7	6 mm UMB	6 mm UMB							
NG□□-FNS4-8	1/4 Female NPT	1/4 Female NPT	0.25 (6.4)	0.70	1.06 (26.9)	1.06 (26.9)	0.49 (12.5)	1.88 (47.8)	2.85 (72.4)
NG□□-FNS6-8	3/8 Female NPT	3/8 Female NPT					0.62 (15.8)		2.90 (73.7)
NG□□-NS6-8	3/8 Male NPT	3/8 Male NPT			1.12 (28.4)	1.12 (28.4)	0.49 (12.5)		2.85 (72.4)
NG□□-NS8-8	1/2 Male NPT	1/2 Male NPT			1.50 (38.1)	1.50 (38.1)	0.62 (15.8)		2.90 (73.7)
NG□□-FL6-8	3/8" FITOK	3/8" FITOK			1.29 (32.8)	1.29 (32.8)			
NG□□-FL8-8	1/2" FITOK	1/2" FITOK			1.40 (35.6)	1.40 (35.6)			
NG□□-ML10-8	10 mm FITOK	10 mm FITOK			1.30 (33.0)	1.30 (33.0)	0.49 (12.5)		2.85 (72.4)
NG□□-ML12-8	12 mm FITOK	12 mm FITOK			1.40 (35.6)	1.40 (35.6)			
NG□□-ML14-8	14 mm FITOK	14 mm FITOK			1.56 (39.7)	1.56 (39.7)			
NG□□-MS20-8	M20 x 1.5 Male Metric	M20 x 1.5 Male Metric			1.50 (38.1)	1.50 (38.1)	0.62 (15.8)		2.90 (73.7)
NG□□-UMB10-8	10 mm UMB	10 mm UMB							
NG□□-UMB14-8	14 mm UMB	14 mm UMB			2.60 (66.0)	2.60 (66.0)	0.49 (12.5)		2.85 (72.4)

Dimensions of NG Series

Basic Ordering Number	Connection Type and Size		Orifice in.(mm)	Cv	Dimensions, in.(mm)				
	Inlet	Outlet			L1	L2	C	D	H
NG□□-FNS8-9-L	1/2 Female NPT	1/2 Female NPT	0.39 (10.0)	1.80	1.50 (38.1)	1.50 (38.1)	0.76 (19.4)	3.50 (88.9)	3.37 (85.7)
NG□□-FNS12-9-L	3/4 Female NPT	3/4 Female NPT			1.56 (39.7)	1.56 (39.7)	0.80 (20.4)		
NG□□-NS12-9-L	3/4 Male NPT	3/4 Male NPT			1.56 (39.7)	1.56 (39.7)	0.76 (19.4)		
NG□□-FL8-9-L	1/2" FITOK	1/2" FITOK			1.90 (48.3)	1.90 (48.3)	0.76 (19.4)		
NG□□-FL12-9-L	3/4" FITOK	3/4" FITOK							
NG□□-ML14-9-L	14 mm FITOK	14 mm FITOK							

1. Connection type of "FITOK" means FITOK double ferrule tube fittings. When the connection type of valves is FITOK double ferrule tube fitting, the working pressures of the valves are related to the wall thickness of used tubing. For specific working pressure of the valves, please refer to the allowable working pressures in FITOK Catalog Tubing.
2. Connection type of "UMB" means rotatable metric tube butt weld.
3. Sizes and types listed are standard. Other sizes and types are available upon request. For details, please contact FITOK Group or our authorized distributors.
4. Dimensions are shown with FITOK tube fitting nuts finger-tight. All dimensions are for reference only and are subject to change. For dimensions not shown above, please contact FITOK Group or our authorized distributors.

Panel Mount Dimensions of NG Series

Orifice in.(mm)	Dimensions, in.(mm)	
	E	F
0.08 (2.0)	0.44 (11.2)	0.47 (11.9)
0.16 (4.0)	0.44 (11.2)	0.53 (13.5)
0.25 (6.4)	0.50 (12.7)	0.78 (19.8)
0.39 (10.0)	0.75 (19.1)	1.03 (26.2)

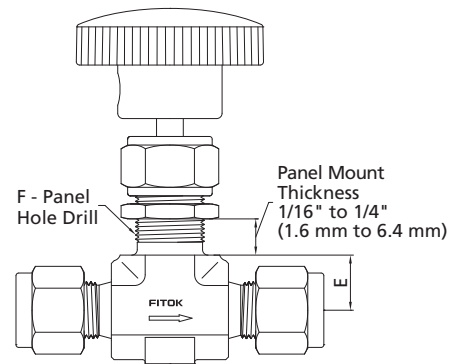

1. NG Series Needle Valves are standard without panel mounting.
2. To order needle valves with panel mounting as illustrated, add -Y to the ordering number. Example: NGSS-NS2-5-Y

Straight Pattern

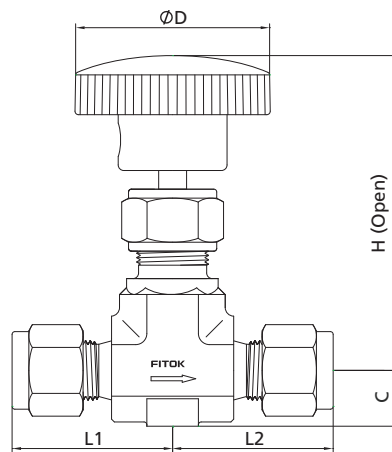

Angle Pattern

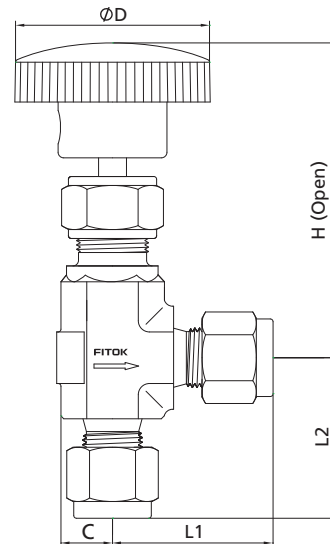

Dimensions of NGH Series

Basic Ordering Number	Connection Type and Size		Orifice in.(mm)	Cv	Dimensions, in.(mm)							
	Inlet	Outlet			L1	L2	C	D	H			
NGH□□-NS2-5	1/8 Male NPT	1/8 Male NPT	0.08 (2.0)	0.09	0.75 (19.0)	0.75 (19.0)	0.32 (8.2)	1.00 (25.4)	2.30 (58.4)			
NGH□□-FNS2-5	1/8 Female NPT	1/8 Female NPT			0.81 (20.6)	0.81 (20.6)						
NGH□□-FL2-5	1/8" FITOK	1/8" FITOK			0.98 (25.0)	0.98 (25.0)						
NGH□□-ML3-5	3 mm FITOK	3 mm FITOK	0.16 (4.0)	0.35	0.81 (20.6)	0.81 (20.6)	0.39 (10.0)	1.38 (35.0)	2.46 (62.5)			
NGH□□-FNS2-7	1/8 Female NPT	1/8 Female NPT			0.98 (25.0)	0.98 (25.0)						
NGH□□-NS4-7	1/4 Male NPT	1/4 Male NPT			1.13 (28.7)	1.13 (28.7)						
NGH□□-FL4-7	1/4" FITOK	1/4" FITOK			1.17 (29.7)	1.17 (29.7)						
NGH□□-ML6-7	6 mm FITOK	6 mm FITOK			2.24 (57.0)	2.24 (57.0)						
NGH□□-ML8-7	8 mm FITOK	8 mm FITOK			1.06 (26.9)	1.06 (26.9)				0.49 (12.5)	1.88 (47.8)	2.85 (72.4)
NGH□□-UMB6-7	6 mm UMB	6 mm UMB	1.12 (28.4)	1.12 (28.4)	0.62 (15.8)	2.90 (73.7)						
NGH□□-FNS4-8	1/4 Female NPT	1/4 Female NPT	1.12 (28.4)	1.12 (28.4)	0.49 (12.5)	2.85 (72.4)						
NGH□□-FNS6-8	3/8" Female NPT	3/8" Female NPT	0.25 (6.4)	0.70	1.50 (38.1)	1.50 (38.1)	0.49 (12.5)	1.88 (47.8)	2.90 (73.7)			
NGH□□-NS6-8	3/8 Male NPT	3/8 Male NPT			1.29 (32.8)	1.29 (32.8)						
NGH□□-NS8-8	1/2 Male NPT	1/2 Male NPT			1.40 (35.6)	1.40 (35.6)						
NGH□□-FL6-8	3/8" FITOK	3/8" FITOK			1.30 (33.0)	1.30 (33.0)						
NGH□□-FL8-8	1/2" FITOK	1/2" FITOK			1.40 (35.6)	1.40 (35.6)						
NGH□□-ML10-8	10 mm FITOK	10 mm FITOK			1.56 (39.7)	1.56 (39.7)				0.62 (15.8)	2.90 (73.7)	
NGH□□-ML12-8	12 mm FITOK	12 mm FITOK			1.50 (38.1)	1.50 (38.1)						
NGH□□-ML14-8	14 mm FITOK	14 mm FITOK			2.60 (66.0)	2.60 (66.0)				0.49 (12.5)	1.88 (47.8)	2.85 (72.4)
NGH□□-MS20-8	M20 x 1.5 Male Metric	M20 x 1.5 Male Metric										
NGH□□-UMB10-8	10 mm UMB	10 mm UMB										
NGH□□-UMB14-8	14 mm UMB	14 mm UMB					2.85 (72.4)					

Dimensions of NGH Series

Basic Ordering Number	Connection Type and Size		Orifice in.(mm)	Cv	Dimensions, in.(mm)				
	Inlet	Outlet			L1	L2	C	D	H
NGH□□-FNS8-9-L	1/2 Female NPT	1/2 Female NPT	0.39 (10.0)	1.80	1.50 (38.1)	1.50 (38.1)	0.76 (19.4)	3.50 (88.9)	3.37 (85.7)
NGH□□-NS12-9-L	3/4 Male NPT	3/4 Male NPT			1.56 (39.7)	1.56 (39.7)	0.76 (19.4)		
NGH□□-FL8-9-L	1/2" FITOK	1/2" FITOK			1.90 (48.3)	1.90 (48.3)	0.76 (19.4)		
NGH□□-FL12-9-L	3/4" FITOK	3/4" FITOK							
NGH□□-ML14-9-L	14 mm FITOK	14 mm FITOK							

1. Connection type of "FITOK" means FITOK double ferrule tube fittings. When the connection type of valves is FITOK double ferrule tube fitting, the working pressures of the valves are related to the wall thickness of tubing applied. For specific working pressure of the valves, please refer to the allowable working pressures in FITOK Catalog Tubing.
2. Connection type of "UMB" means rotatable metric tube butt weld.
3. Sizes and types listed are standard. Other sizes and types are available upon request. For details, please contact FITOK Group or our authorized distributors.
4. Dimensions are shown with FITOK tube fitting nuts finger-tight. All dimensions are for reference only and are subject to change. For dimensions not shown above, please contact FITOK Group or our authorized distributors.

Panel Mount Dimensions of NGH Series

Orifice in.(mm)	Dimensions, in.(mm)	
	E	F
0.08 (2.0)	0.44 (11.2)	0.47 (11.9)
0.16 (4.0)	0.44 (11.2)	0.53 (13.5)
0.25 (6.4)	0.50 (12.7)	0.78 (19.8)
0.39 (10.0)	0.75 (19.1)	1.03 (26.2)

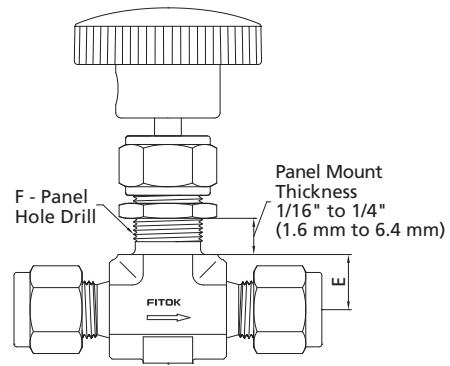

1. NGH Series Needle Valves are standard without panel mounting.
2. To order needle valves with panel mounting as illustrated, add -Y to the ordering number. Example: NGHSS-NS2-5-Y

Ordering Number Description

NGS4 - FNS8 - FL8 - 9P - PYM - ASF2

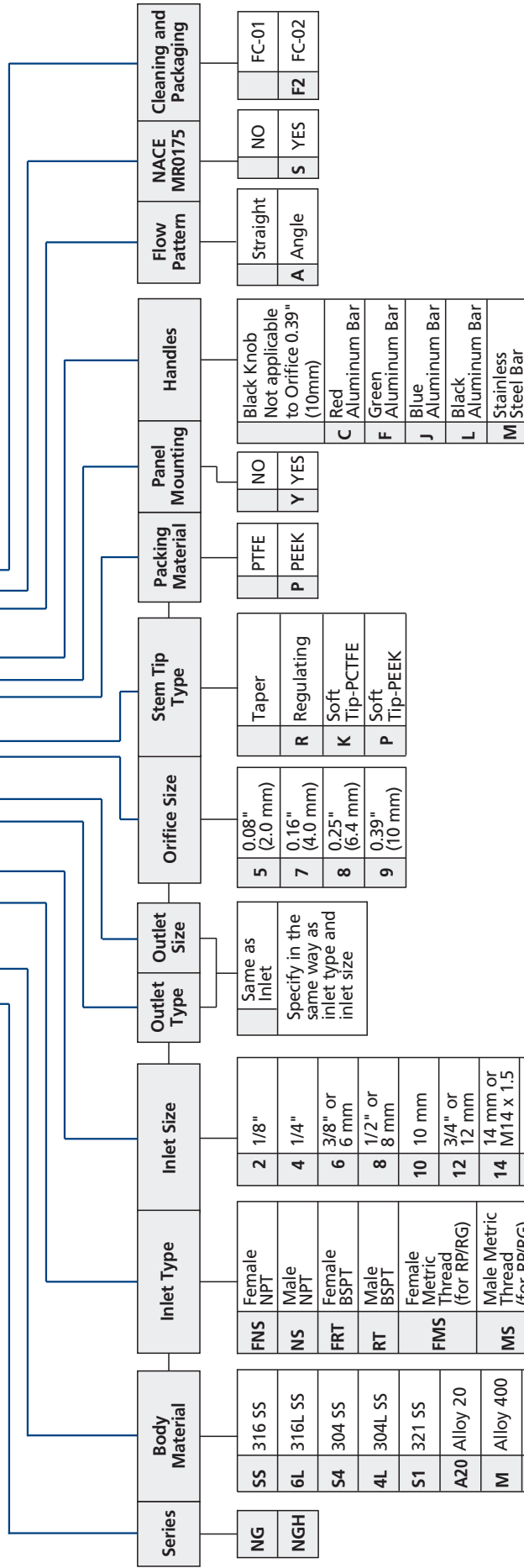

NOTE: "Ordering Number Description" is a reference to understand the combination rules of FITOK product part number. Not all combinations are available.

- Standard thread pitch for metric threads are as follows:
 M10 and below: 1 mm
 M12 to M24: 1.5 mm
 M27 and above: 2 mm
 Standard thread pitch should be omitted in the ordering number, others should be specified.
 For Orifice 0.39" (10 mm) needle valves, the option of black knob handle is unavailable.
 If handle designator is void, a black anodized Aluminum bar handle should be equipped.
- Cleaning and Packaging:
 FC-01: Standard cleaning and packaging for general industrial procedures.
 FC-02: Special cleaning and packaging for wetted system components to ensure compliance with product cleanliness requirement of ASTM G93 Level C.

Rising Plug Valves

NR Series NRG (with gauge port) Series

Features

- ⦿ Cold drawn square bar as body material
- ⦿ Nonrotating stem for longer seat life
- ⦿ Roddable, straight through flow path for maximum flow with minimum pressure drop
- ⦿ Stem thread lubricant isolated from system media
- ⦿ Replaceable seat and stem tip design
- ⦿ Stem thread protected from outside contamination by PTFE ring in the gland
- ⦿ Panel mounting available
- ⦿ Handles of different colors available
- ⦿ Every valve leak tested with Nitrogen or compressed air at the maximum allowable working pressure
- ⦿ Working pressure up to:
 - Stainless steel: 6000 psig (414 bar)
 - Alloy 400: 5000 psig (345 bar)
- ⦿ Working temperature with seat:
 - Acetal: -20°F to 250°F (-28°C to 121°C)
 - PEEK: -20°F to 450°F (-28°C to 232°C)
- ⦿ Working temperature with O-ring:
 - Fluorocarbon Rubber (FKM): -20°F to 400°F (-28°C to 204°C)
 - Nitrile Butadiene Rubber (NBR): -20°F to 212°F (-28°C to 100°C)
 - Ethylene Propylene Diene Rubber (EPDM): -20°F to 300°F (-28°C to 148°C)



Pressure vs. Temperature

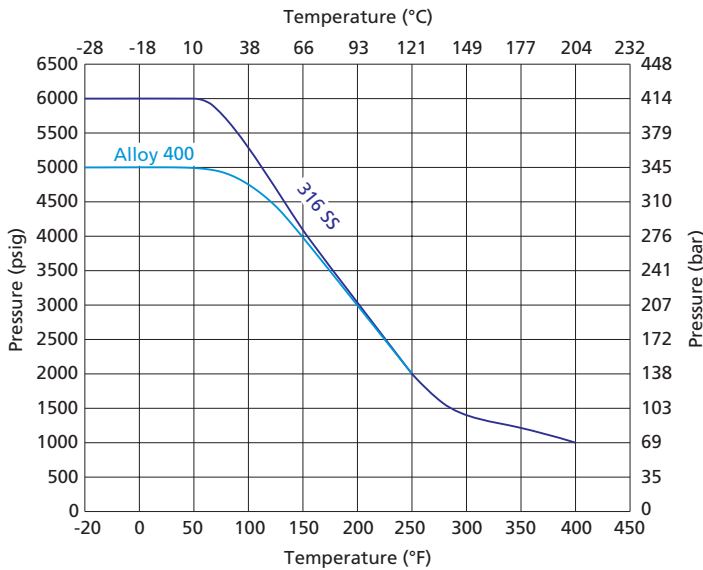

Flow Data at 100°F (38°C)

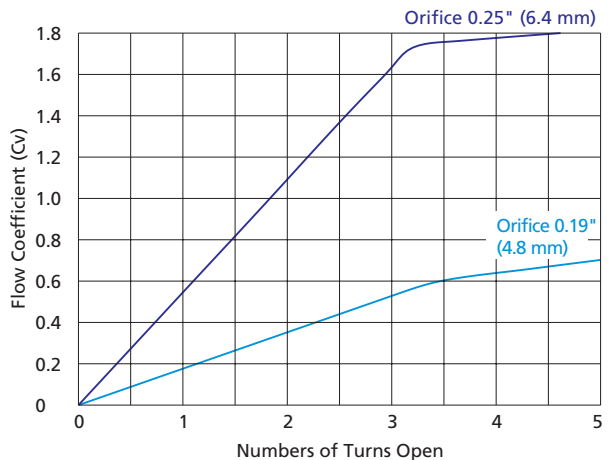

1. Graphs are based on PEEK seat and Fluorocarbon(FKM) O-ring.
2. Contact FITOK Group or our authorized distributors for curve graph of other materials.

Standard Materials of Construction

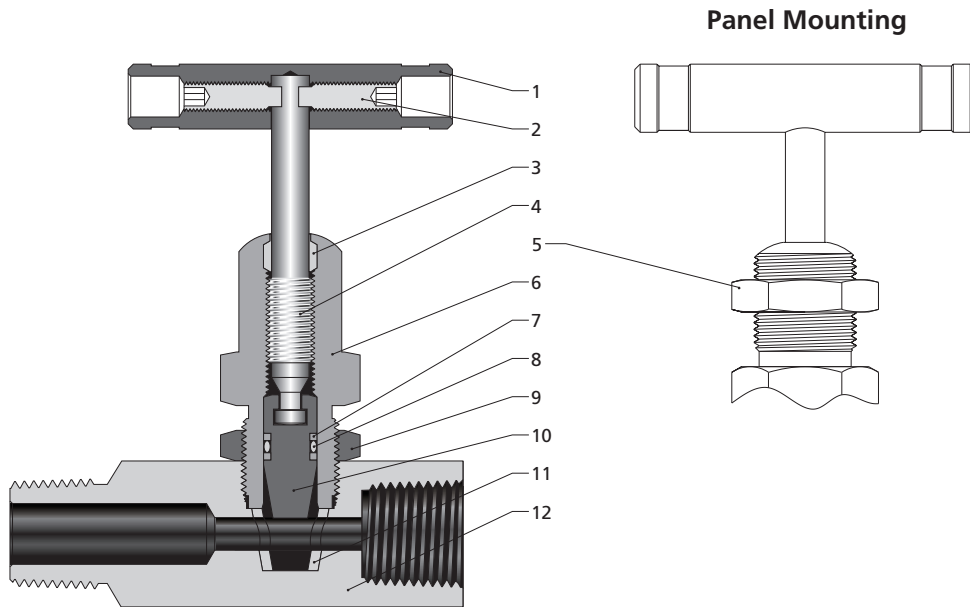

Item	Component	Valve Body Material			
		316 SS	304 SS	321 SS	Alloy 400
Material Grade/ASTM Specification					
1	Handle	Anodized aluminum or stainless steel or black knob			
2	Set Screw	Galvanized carbon steel			
3	Wiper Ring	PTFE/D1710			
4	Upper Stem	316 SS/A479			Alloy 400/B164
5	Panel Nut	Stainless steel			
6	Bonnet	316 SS/A479	304 SS/A479	321 SS/A479	Alloy 400/B164
7	Backup Ring	PTFE/D1710			
8	O-ring	Fluorocarbon Rubber (FKM), Nitrile Butadiene Rubber (NBR) or Ethylene Propylene Diene Rubber (EPDM)			
9	Lock Nut	Stainless steel			
10	Stem Tip	316 SS/A479	304 SS/A479	321 SS/A479	Alloy 400/B164
11	Seat	Acetal or PEEK			
12	Body	316 SS/A479	304 SS/A479	321 SS/A479	Alloy 400/B164
	Lubricant	Molybdenum disulfide-based			

Note: Contact FITOK Group or our authorized distributors for other materials.

Dimensions

Standard Pattern
NR Series

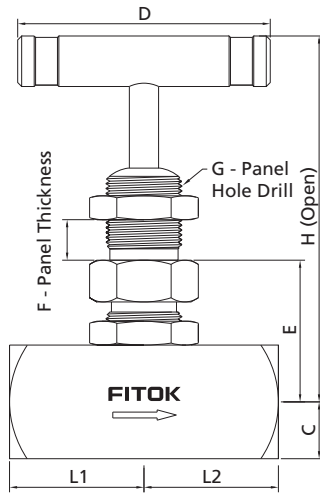

Gauge Port Pattern
NRG Series

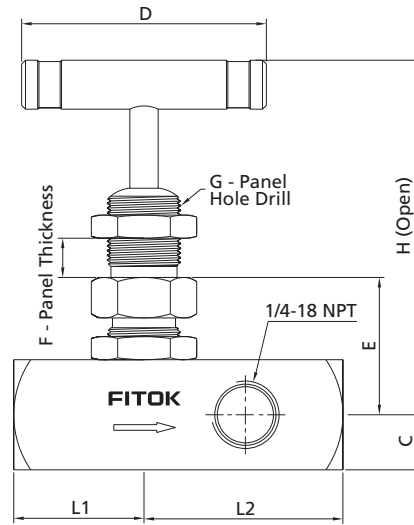

© NR Series Needle Valves are standard without panel mounting. To order needle valves with panel mounting as illustrated, add -Y to the ordering number. Example: NR55-FNS4-7-Y

Dimensions of NR and NRG Series

Basic Ordering Number	Connection Type and Size		Orifice in.(mm)	Cv	Dimensions, in.(mm)							
	Inlet	Outlet			L1	L2	C	D	E	F	G	H
NR □□ -FNS4-7	1/4 Female NPT	1/4 Female NPT	0.19 (4.8)	0.63	1.12 (28.4)	1.12 (28.4)	0.44 (11.1)	2.17 (55.0)	1.28 (32.5)	0.38 (9.7)	0.77 (19.6)	3.77 (95.8)
NR □□ -NS4-FNS4-7	1/4 Male NPT	1/4 Female NPT			1.78 (45.2)				1.34 (34.0)			
NR □□ -NS8-FNS4-7	1/2 Male NPT	1/4 Female NPT			1.89 (48.0)				0.50 (12.7)			
NRG □□ -FNS4-7	1/4 Female NPT	1/4 Female NPT			1.12 (28.4)	1.75 (44.4)						
NRG □□ -NS8-FNS4-7	1/2 Male NPT	1/4 Female NPT			3.12 (79.2)							
NR □□ -FNS8-8	1/2 Female NPT	1/2 Female NPT	0.25 (6.4)	1.80	1.33 (33.8)	1.33 (33.8)	0.56 (14.3)	2.50 (63.5)	1.40 (35.5)	0.38 (9.7)	0.77 (19.6)	3.83 (97.3)
NR □□ -NS8-FNS8-8	1/2 Male NPT	1/2 Female NPT			2.16 (54.9)							
NR □□ -NS12-FNS8-8	3/4 Male NPT	1/2 Female NPT			3.33 (84.6)							
NRG □□ -FNS8-8	1/2 Female NPT	1/2 Female NPT										
NRG □□ -NS12-FNS8-8	3/4 Male NPT	1/2 Female NPT										

1. Sizes and types listed are standard. Other sizes and types are available upon request.
2. For dimensions not shown above, please contact FITOK Group or our authorized distributors.

Ordering Number Description

NRSS - NS8 - FNS8 - P8 - BYM - SF2

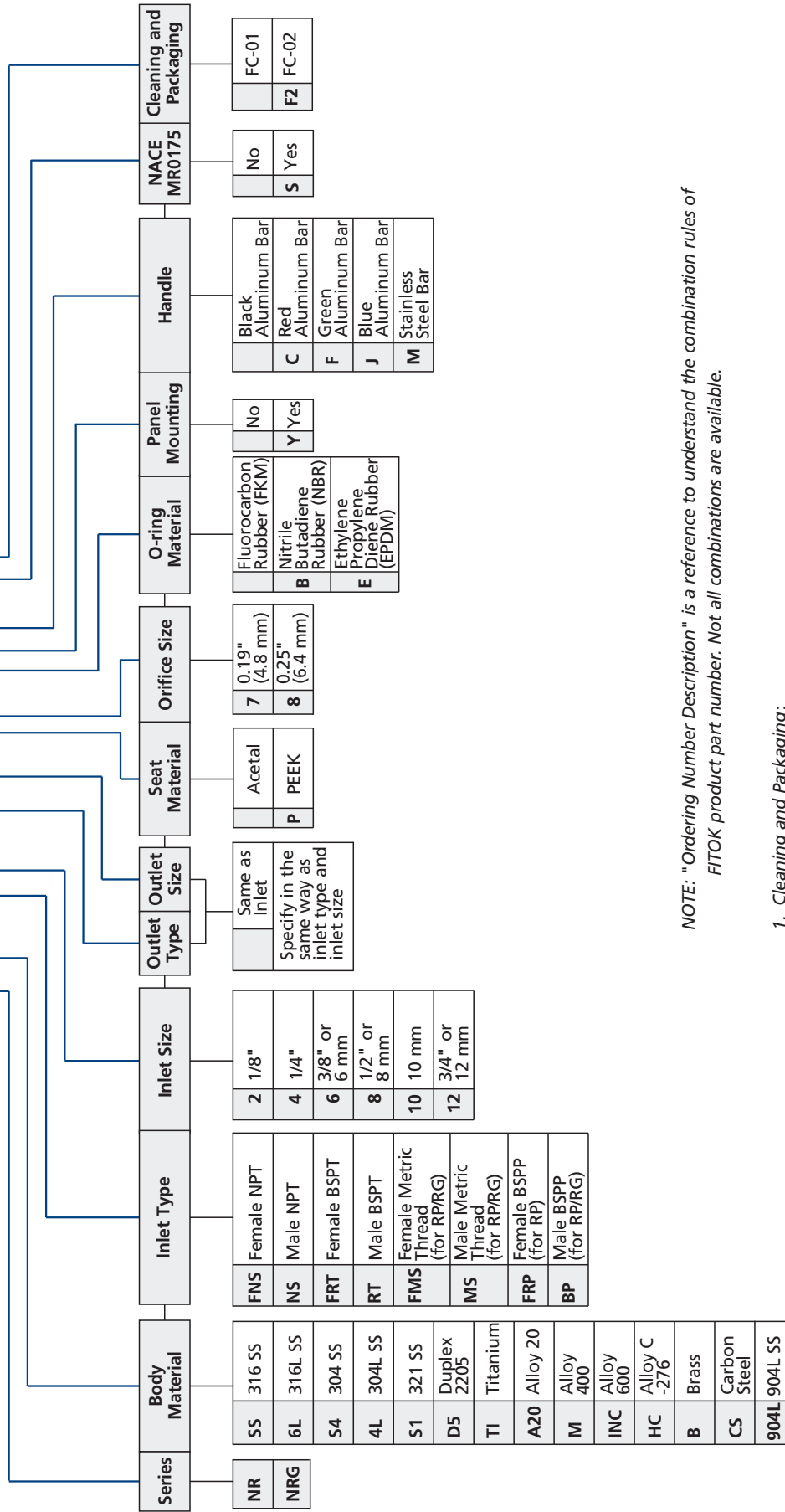

NOTE: "Ordering Number Description" is a reference to understand the combination rules of FITOK product part number. Not all combinations are available.

1. Cleaning and Packaging:
 FC-01: Standard cleaning and packaging for general industrial procedures.
 FC-02: Special cleaning and packaging for wetted system components to ensure compliance with product cleanliness requirement of ASTM G93 Level C.

Toggle Valves

NT Series

Features

- ⦿ One piece forged body
- ⦿ Straight and angle patterns
- ⦿ Compact design
- ⦿ Quick opening or closing
- ⦿ Nonrotating stem
- ⦿ Panel mounting available
- ⦿ Every valve leak tested with Nitrogen or compressed air at the maximum allowable working pressure
- ⦿ Working pressure up to: 300 psig (20.7 bar)



Technical Data

Orifice in. (mm)	Working Pressure at 100°F (38°C) psig (bar)	O-ring Material	Temperature Rating
0.08 (2.0)	300 (20.7)	Fluorocarbon Rubber (FKM)	-20°F to 400°F (-28°C to 204°C)
0.125 (3.2)		Nitrile Butadiene Rubber (NBR)	-20°F to 212°F (-28°C to 100°C)
0.25 (6.4)	200 (13.8)	Ethylene Propylene Diene Rubber (EPDM)	-20°F to 300°F (-28°C to 148°C)

Standard Materials of Construction

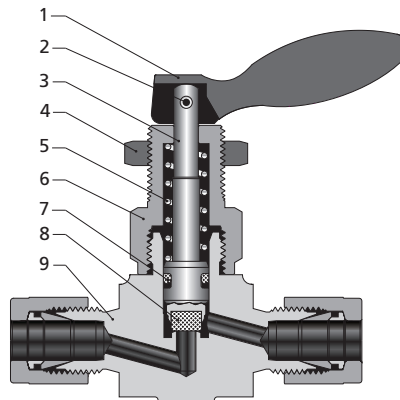

Item	Component	Valve Body Material			
		316 SS	304 SS	321 SS	Brass
		Material Grade/ASTM Specification			
1	Handle	Stainless steel			
2	Pin	Stainless steel			
3	Stem	316 SS/A479	304 SS/A479		316 SS/A479
4	Panel Nut	Stainless steel			Brass C36000/B16
5	Spring	S17700/A313			
6	Bonnet	304 SS/A479			Brass C36000/B16
7	O-ring	Fluorocarbon Rubber (FKM), Nitrile Butadiene Rubber (NBR) or Ethylene Propylene Diene Rubber (EPDM)			
8	Stem Tip	PTFE/D1710			
9	Body	316 SS/A182	304 SS/A182	321 SS/A182	Brass C37700/B283
	Lubricant	Molybdenum disulfide-based			

Note: Contact FITOK Group or our authorized distributors for other materials.

Dimensions

Straight Pattern

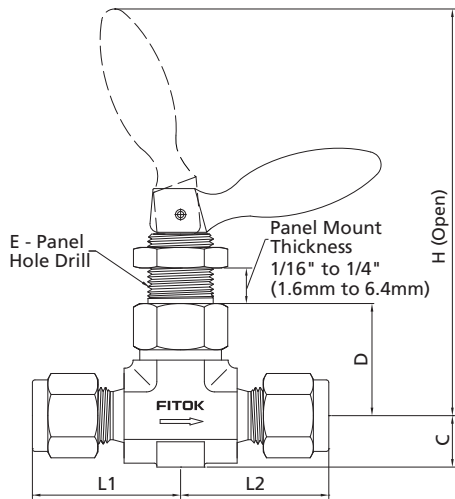

Angle Pattern

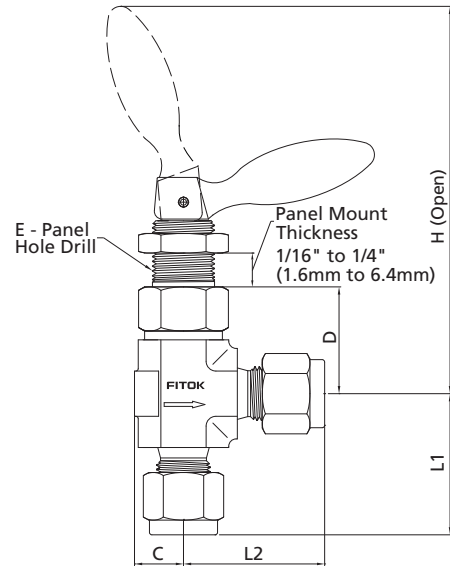

Dimensions of NT series

Basic Ordering Number	Connection Type and Size		Orifice in.(mm)	Cv	Dimensions, in.(mm)					
	Inlet	Outlet			L1	L2	C	D	E	H
NT□□-NS2-5	1/8 Male NPT	1/8 Male NPT	0.08 (2.0)	0.11	0.75 (19.05)	0.75 (19.05)	0.32 (8.2)	0.85 (21.7)	0.53 (13.5)	2.83 (71.9)
NT□□-NS2-FL2-5	1/8 Male NPT	1/8" FITOK			0.75 (19.05)	0.98 (25.0)				
NT□□-FL2-5	1/8" FITOK	1/8" FITOK			0.98 (25.0)	0.98 (25.0)				
NT□□-ML3-5	3 mm FITOK	3 mm FITOK								
NT□□-FNS2-7	1/8 Female NPT	1/8 Female NPT	0.125 (3.2)	0.20	0.81 (20.6)	0.81 (20.6)	0.39 (10.0)	0.85 (21.7)	0.53 (13.5)	2.83 (71.9)
NT□□-NS2-7	1/8 Male NPT	1/8 Male NPT			0.86 (21.8)	0.86 (21.8)				
NT□□-NS4-7	1/4 Male NPT	1/4 Male NPT			0.98 (25.0)	0.98 (25.0)				
NT□□-NS4-FL4-7	1/4 Male NPT	1/4" FITOK			0.98 (25.0)	1.13 (28.7)				
NT□□-FL4-7	1/4" FITOK	1/4" FITOK			1.13 (28.7)					
NT□□-ML6-7	6 mm FITOK	6 mm FITOK								
NT□□-ML8-7	8 mm FITOK	8 mm FITOK								
NT□□-FNS4-8	1/4 Female NPT	1/4 Female NPT			0.25 (6.4)	0.70				
NT□□-FNS6-8	3/8 Female NPT	3/8 Female NPT	1.12 (28.4)	1.12 (28.4)						
NT□□-NS6-8	3/8 Male NPT	3/8 Male NPT	1.29 (32.8)	1.29 (32.8)						
NT□□-FL6-8	3/8" FITOK	3/8" FITOK	1.40 (35.6)	1.40 (35.6)						
NT□□-FL8-8	1/2" FITOK	1/2" FITOK	1.36 (34.5)	1.36 (34.5)						
NT□□-ML10-8	10 mm FITOK	10 mm FITOK	1.46 (37.1)	1.46 (37.1)						
NT□□-ML12-8	12 mm FITOK	12 mm FITOK								

1. Connection type of "FITOK" means FITOK double ferrule tube fittings.
2. Sizes and types listed are standard. Other sizes and types are available upon request. For details, please contact FITOK Group or our authorized distributors.
3. Dimensions are shown with FITOK tube fitting nuts finger-tight. All dimensions are for reference only and are subject to change. For dimensions not shown above, please contact FITOK Group or our authorized distributors.

Pneumatic Actuators

Features

- Valve and actuator are fully assembled and every valve leak tested with Nitrogen or compressed air at the maximum allowable working pressure
- Opens and closes quickly and reliably
- Rotatable actuator port allows easy installation

Actuation Modes

- Normally closed—air opens, spring closes
- Normally open—air closes, spring opens
- Double acting—air opens and closes

Normally Closed and Double Acting



Normally Open



Technical Data

Actuator Type	Working Pressure at 100°F (38°C) psig (bar)	Actuator Pressure Rating psig (bar)
Normally closed	300 (20.7)	87 (6)
Normally open	450 (31.0)	
Double acting		

Component	Material
	Material Grade/ASTM Specification
Housing	Anodized aluminum
Spring	S17700/A313
Mounting Bracket	304SS/A240
Stem Tip	Normally open, normally closed—PTFE/D1710, double acting—PCTFE/D1430

Please refer to NT Series "Standard Materials of Construction" for other materials.

Dimensions

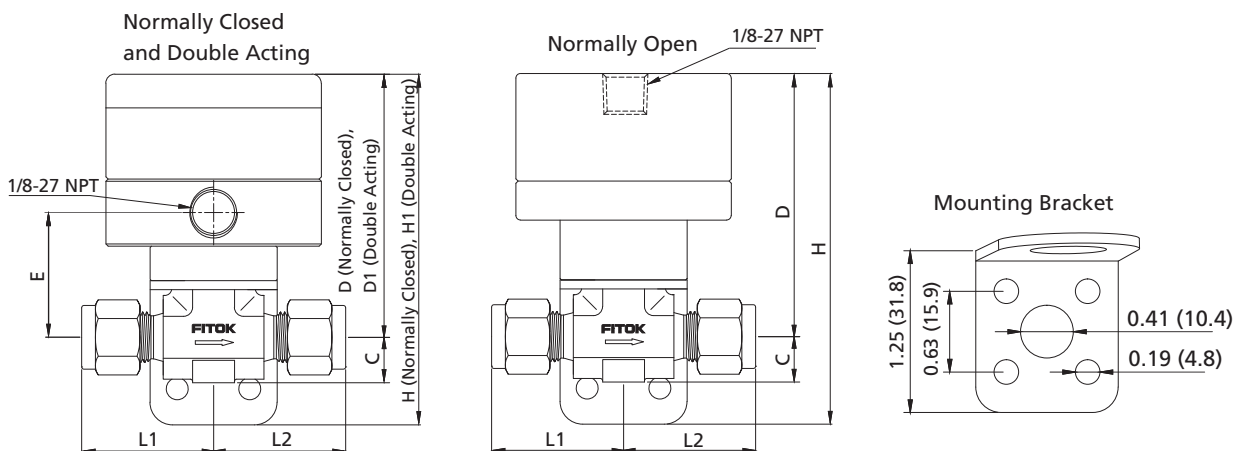

Basic Ordering Number	Connection Type and Size		Orifice in.(mm)	Cv	Dimensions, in.(mm)							
	Inlet	Outlet			L1	L2	C	D	D1	H	H1	E
NT□□-NS2-5-LC-Y	1/8 Male NPT	1/8 Male NPT	0.08 (2.0)	0.11	0.86 (21.8)	0.86 (21.8)						
NT□□-NS2-FL2-5-LC-Y	1/8 Male NPT	1/8" FITOK			0.86 (21.8)	1.03 (26.2)						
NT□□-FL2-5-LC-Y	1/8" FITOK	1/8" FITOK			1.03 (26.2)	1.03 (26.2)						
NT□□-ML3-5-LC-Y	3 mm FITOK	3 mm FITOK	0.125 (3.2)	0.20	0.81 (20.6)	0.81 (20.6)	0.39 (10.0)	2.28 (58)	2.46 (62.5)	3.04 (77.3)	3.22 (81.8)	1.08 (27.5)
NT□□-FNS2-7-LC-Y	1/8 Female NPT	1/8 Female NPT			0.86 (21.8)	0.86 (21.8)						
NT□□-NS2-7-LC-Y	1/8 Male NPT	1/8 Male NPT			0.98 (25.0)	0.98 (25.0)						
NT□□-NS4-7-LC-Y	1/4 Male NPT	1/4 Male NPT			0.98 (25.0)	1.13 (28.7)						
NT□□-NS4-FL4-7-LC-Y	1/4 Male NPT	1/4" FITOK			1.13 (28.7)							
NT□□-FL4-7-LC-Y	1/4" FITOK	1/4" FITOK										
NT□□-ML6-7-LC-Y	6 mm FITOK	6 mm FITOK										
NT□□-ML8-7-LC-Y	8 mm FITOK	8 mm FITOK										

1. Connection type of "FITOK" means FITOK double ferrule tube fittings.
2. Sizes and types listed are standard. Other sizes and types are available upon request. For details, please contact FITOK Group or our authorized distributors.
3. Dimensions are shown with FITOK tube fitting nuts finger-tight. All dimensions are for reference only and are subject to change. For dimensions not shown above, please contact FITOK Group or our authorized distributors.

Ordering Number Description

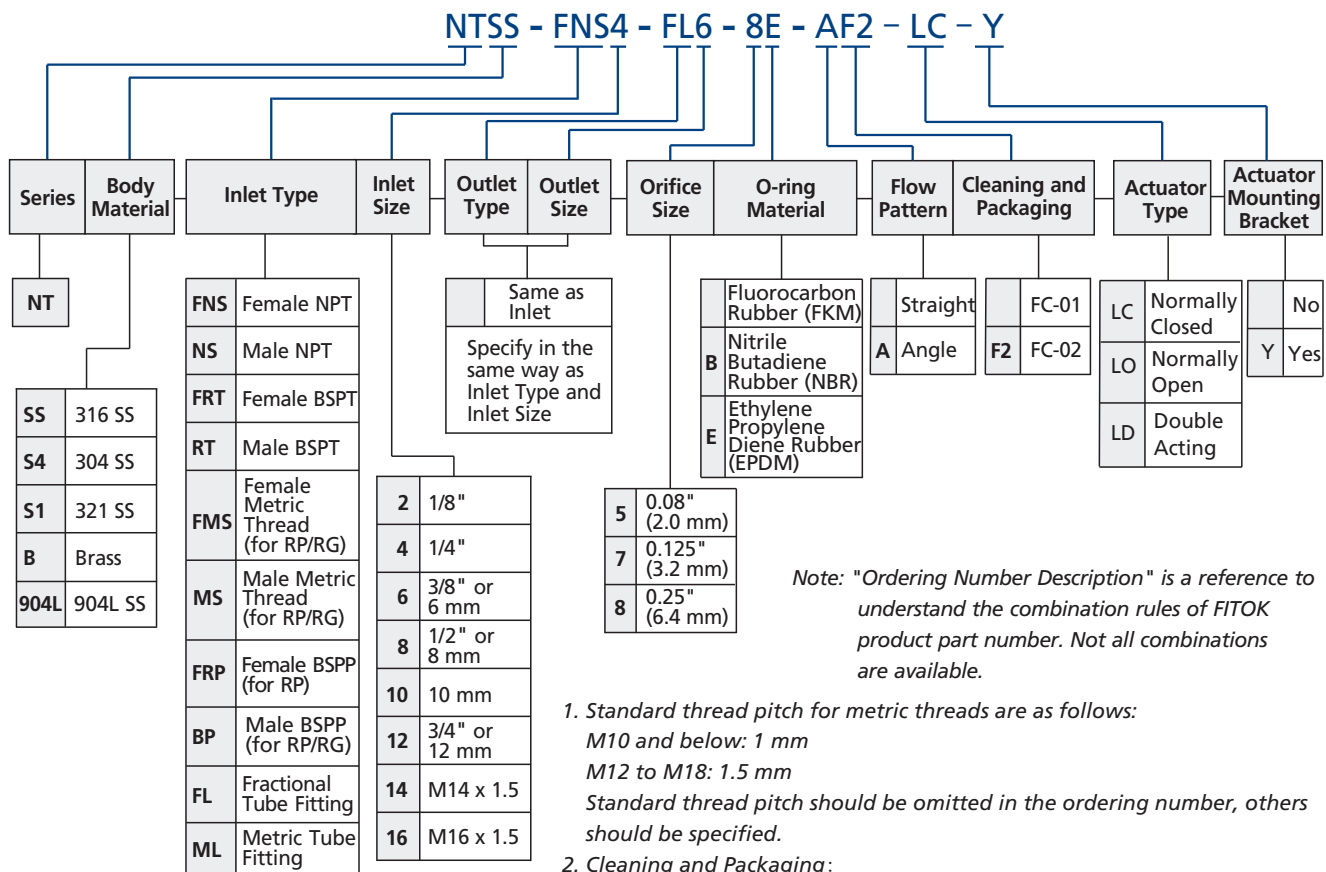

Union Bonnet Needle Valves

NU Series: Working pressure up to 6000 psig

NUH Series: Working pressure up to 10000 psig

Features

- ⦿ One-piece forged body
- ⦿ Two-piece stem design: Upper stem threads cold rolled and lower stem hardened for high strength and smooth operation
- ⦿ Accidental valve disassembly disabled by union bonnet construction
- ⦿ Upper stem thread lubricant isolated from system media
- ⦿ Linear instead of rotary movement of the rising, non-rotating stem minimizes packing abrasion and reduces the friction between the seat and the tip
- ⦿ Safety back seating seal in fully open position
- ⦿ Panel mounting available
- ⦿ Steady and durable fastening of the handle by double lock-pins
- ⦿ Handles of different colors available
- ⦿ Every valve leak tested with Nitrogen or compressed air (NU Series) at the maximum allowable working pressure or with water (NUH Series) at 1.1 times the maximum allowable pressure
- ⦿ Working pressure up to:
 - NU Series—Stainless steel: 6000 psig (414 bar)
 - Alloy C-276: 6000 psig (414 bar)
 - Alloy 400: 5000 psig (345 bar)
 - Titanium: 3500 psig (241 bar)
 - NUH Series—Stainless steel: 10000 psig (690 bar)
- ⦿ Working temperature:
 - PTFE: -65°F to 450°F (-54°C to 232°C)
 - PEEK: -65°F to 500°F (-54°C to 260°C)
 - Graphite: -65°F to 1200°F (-54°C to 649°C)



Pressure vs. Temperature

NU Series

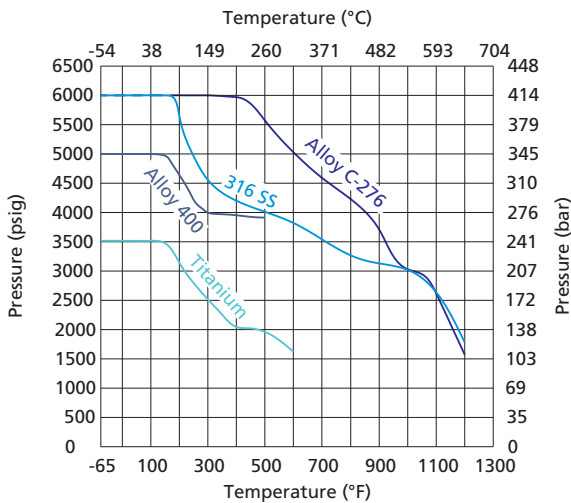

NUH Series

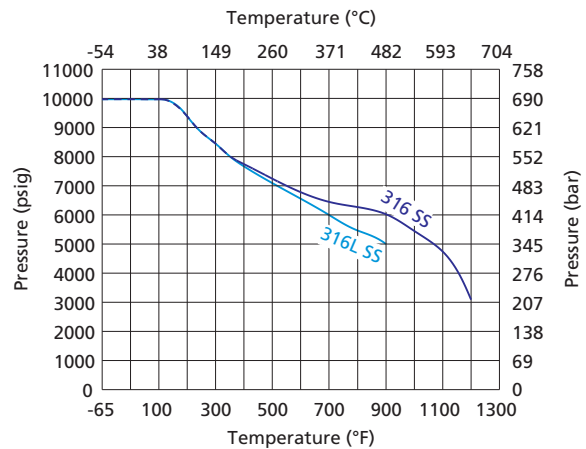

1. Graphs are based on graphite packing.
2. Soft tips are for NU Series only. Temperature rating is limited to 200°F (93°C) max. with PCTFE stem tip (soft tip).
3. Contact FITOK Group or our authorized distributors for curve graph of other materials.

Flow Data at 100°F (37°C)

Regulating Stem

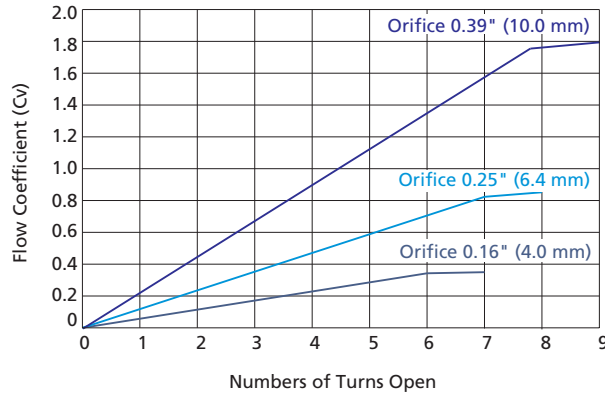

Standard Materials of Construction

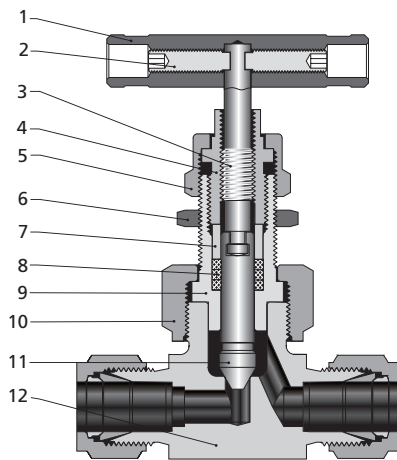

Stem Type

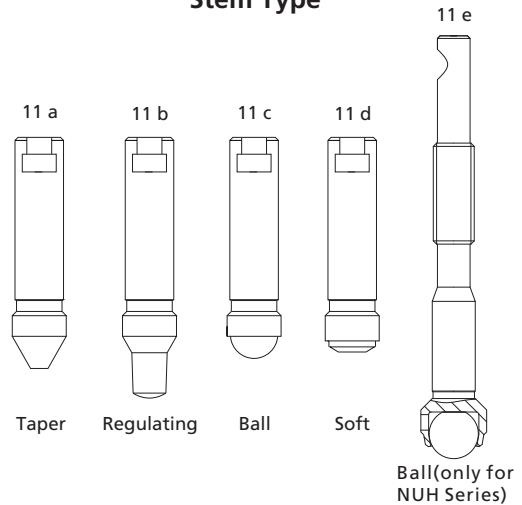

Needle Valves
Metering Valves

Item	Component	Valve Body Material			
		316 SS	Alloy 400	Titanium	Alloy C-276
		Material Grade/ASTM Specification			
1	Handle	Anodized aluminium or stainless steel or black knob			
2	Set Screw	Galvanized carbon steel			
3	Upper Stem	316 SS/A479			
4	Packing Bolt	304 SS/A479			
5	Lock Nut	316 SS/A479			
6	Panel Nut	Stainless steel			
7	Gland	316 SS/A479			
8	Packing	PTFE or PEEK or graphite			
9	Bonnet	316 SS/A479	Alloy 400/B164	Titanium Gr 4/B348	Alloy C-276/B574
10	Union Nut	316 SS/A479			
11a 11b 11c	Lower Stem	Hardened 316 SS/A479	Alloy 400/B164	Titanium Gr 4/B348	Alloy C-276/B574
11d	Stem	316 SS/A479	Alloy 400/B164	Titanium Gr 4/B348	Alloy C-276/B574
	Stem Tip	PTFE or PCTFE or PEEK			
11e	Stem	316 SS/A479	Not Applicable		Alloy C-276/B574
	Stem Tip	Stellite			
12	Body	316 SS/A182	Alloy 400/B164, B127, B564	Titanium Gr 4/B348 or titanium Gr 4/B381	Alloy C-276/B564
	Seat	Same as Body			
Lubricant		Molybdenum disulfide-based			

Note: Contact FITOK Group or our authorized distributors for other materials.

Dimensions

Straight Pattern

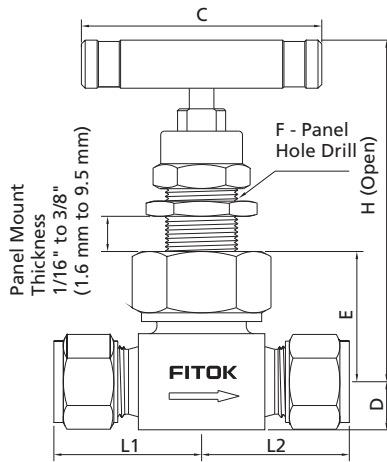

Angle Pattern

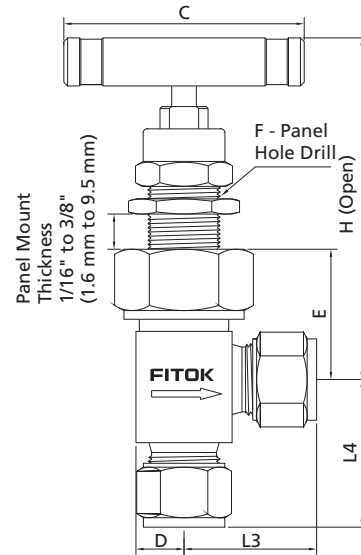

Dimensions of NU Series

Basic Ordering Number	Connection Type and Size		Orifice in.(mm)	Cv	Dimensions, in.(mm)															
	Inlet	Outlet			L1	L2	L3	L4	C	D	E	F	H							
NU□□-FNS2-7	1/8 Female NPT	1/8 Female NPT	0.16 (4.0)	0.35	1.00 (25.4)	1.00 (25.4)	0.89 (22.6)	1.00 (25.4)	1.75 (44.5)	0.39 (9.9)	1.09 (27.7)	0.59 (15.0)	3.06 (77.7)							
NU□□-FNS4-7	1/4 Female NPT	1/4 Female NPT			1.03 (26.2)	1.03 (26.2)														
NU□□-NS4-FNS4-7	1/4 Male NPT	1/4 Female NPT			1.00 (25.4)	1.03 (26.2)														
NU□□-NS4-7	1/4 Male NPT	1/4 Male NPT			1.00 (25.4)	1.00 (25.4)	1.00 (25.4)													
NU□□-NS6-7	3/8 Male NPT	3/8 Male NPT			1.03 (26.2)	1.03 (26.2)	0.89 (22.6)													
NU□□-FRP4-7	1/4 Female BSPP	1/4 Female BSPP			1.00 (25.4)	1.22 (30.9)	1.14 (29.0)													
NU□□-NS4-FL4-7	1/4 Male NPT	1/4" FITOK			1.03 (26.2)	1.22 (30.9)														
NU□□-FNS4-FL4-7	1/4 Female NPT	1/4" FITOK			1.22 (30.9)	1.22 (30.9)	1.15 (29.2)							1.22 (30.9)						
NU□□-FL4-7	1/4" FITOK	1/4" FITOK			1.00 (25.4)	1.00 (25.4)	0.85 (21.6)							1.00 (25.4)						
NU□□-ML6-7	6 mm FITOK	6 mm FITOK			1.03 (26.2)	1.03 (26.2)	1.10 (28.0)							1.10 (28.0)						
NU□□-ML8-7	8 mm FITOK	8 mm FITOK			1.00 (25.4)	1.00 (25.4)	0.25 (6.4)							0.8	1.00 (25.4)	2.50 (63.5)	0.50 (12.7)	1.34 (34.0)	0.78 (19.8)	3.78 (96.0)
NU□□-TS4-7-G	1/4" TS	1/4" TS			1.13 (28.6)	1.13 (28.6)														
NU□□-FO4-7	1/4" Male FO	1/4" Male FO	1.06 (26.9)		1.28 (32.5)	1.47 (37.3)														
NU□□-FR4-7	1/4" Male FR	1/4" Male FR	1.41 (35.9)	1.41 (35.9)	1.40 (35.6)	1.58 (40.1)														
NU□□-FNS4-8	1/4 Female NPT	1/4 Female NPT	1.52 (38.6)	1.52 (38.6)	1.30 (33.0)	1.48 (37.6)														
NU□□-FL6-8	3/8" FITOK	3/8" FITOK	1.42 (36.1)	1.42 (36.1)																
NU□□-FL8-8	1/2" FITOK	1/2" FITOK																		
NU□□-ML10-8	10 mm FITOK	10 mm FITOK																		

Dimensions of NU Series

Basic Ordering Number	Connection Type and Size		Orifice in.(mm)	Cv	Dimensions, in.(mm)								
	Inlet	Outlet			L1	L2	L3	L4	C	D	E	F	H
NU □□-ML12-8	12 mm FITOK	12 mm FITOK	0.25 (6.4)	0.86	1.52 (38.6)	1.52 (38.6)	1.40 (35.6)	1.58 (40.1)	2.50 (63.5)	0.50 (12.7)	1.34 (34.0)	0.78 (19.8)	3.78 (96.0)
NU □□-ML14-8	14 mm FITOK	14 mm FITOK											
NU □□-ML16-8	16 mm FITOK	16 mm FITOK											
NU □□-TS6-8-G	3/8" TS	3/8" TS											
NU □□-TS8-8-G	1/2" TS	1/2" TS											
NU □□-PS4-8-G	1/4 PS	1/4 PS											
NU □□-MTS12-8-G	12 mm MTS	12 mm MTS											
NU □□-MTS14-8-G	14 mm MTS	14 mm MTS											
NU □□-MTS16-8-G	16 mm MTS	16 mm MTS											
NU □□-MTB14-8-G	14 mm MTB	14 mm MTB											
NU □□-MTB16-8-G	16 mm MTB	16 mm MTB											
NU □□-UMB14-8	14 mm UMB	14 mm UMB											
NU □□-FO8-8	1/2" Male FO	1/2" Male FO											
NU □□-FR8-8	1/2" Male FR	1/2" Male FR											
NU □□-MS20-8	M20 x 1.5 Male Metric	M20 x 1.5 Male Metric											
NU □□-MS22-8	M22 x 1.5 Male Metric	M22 x 1.5 Male Metric											
NU □□-NS8-9	1/2 Male NPT	1/2 Male NPT	0.39 (10.0)	1.8	1.56 (39.6)	1.56 (39.6)	1.56 (39.6)	1.56 (39.6)	3.50 (88.9)	0.63 (16.0)	1.82 (46.2)	1.03 (26.2)	4.76 (121)
NU □□-FNS8-9	1/2 Female NPT	1/2 Female NPT											
NU □□-FNS12-9	3/4 Female NPT	3/4 Female NPT											
NU □□-NS12-9	3/4 Male NPT	3/4 Male NPT											
NU □□-FL8-9	1/2" FITOK	1/2" FITOK											
NU □□-FL12-9	3/4" FITOK	3/4" FITOK											
NU □□-ML14-9	14 mm FITOK	14 mm FITOK											
NU □□-ML16-9	16 mm FITOK	16 mm FITOK											
NU □□-ML18-9	18 mm FITOK	18 mm FITOK											
NU □□-ML20-9	20 mm FITOK	20 mm FITOK											
NU □□-MTS14-9-G	14 mm MTS	14 mm MTS											
NU □□-MTS16-9-G	16 mm MTS	16 mm MTS											
NU □□-TS8-9-G	1/2" TS	1/2" TS											
NU □□-TS12-9-G	3/4" TS	3/4" TS											
NU □□-MTB16-9-G	16 mm MTB	16 mm MTB											
NU □□-UMB14-9	14 mm UMB	14 mm UMB											
NU □□-FR8-9	1/2" Male FR	1/2" Male FR											
NU □□-MS27-9	M27 x 2 Male Metric	M27 x 2 Male Metric											

1. Connection type of "FITOK" means FITOK double ferrule tube fittings. When the connection type of valves is FITOK double ferrule tube fitting, the working pressures of the valves are related to the wall thickness of tubing applied. For specific working pressure of the valves, please refer to the allowable working pressures in FITOK Catalog Tubing.
2. Connection type of "TS" means fractional tube socket weld. "MTS" means metric tube socket weld. "MTB" means metric tube butt weld. "UMB" means rotatable metric tube butt weld. "PS" means pipe socket weld.
4. Sizes and types listed are standard. Other sizes and types are available upon request. For details, please contact FITOK Group or our authorized distributors.
5. Dimensions are shown with FITOK tube fitting nuts finger-tight. All dimensions are for reference only and are subject to change. For dimensions not shown above, please contact FITOK Group or our authorized distributors.

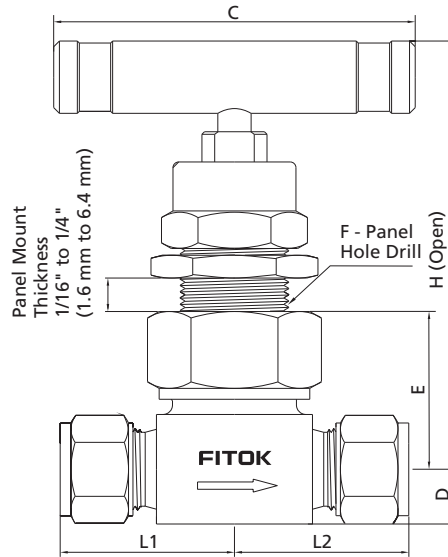

Dimensions of NUH Series

Basic Ordering Number	Connection Type and Size		Orifice in.(mm)	Cv	Dimensions, in.(mm)								
	Inlet	Outlet			L1	L2	C	D	E	F	H		
NUH□□-FL4-7	1/4" FITOK	1/4" FITOK	0.16 (4.0)	0.35	1.41 (35.8)	1.41 (35.8)	2.50 (63.5)	0.50 (12.7)	1.34 (34.1)	0.78 (19.8)	3.42 (86.9)		
NUH□□-FNS2-7	1/8 Female NPT	1/8 Female NPT											
NUH□□-FNS4-7	1/4 Female NPT	1/4 Female NPT			1.13 (28.6)	1.13 (28.6)							
NUH□□-NS4-FNS4-7	1/4 Male NPT	1/4 Female NPT											
NUH□□-NS4-7	1/4 Male NPT	1/4 Male NPT											
NUH□□-TS4-7-G	1/4" TS	1/4" TS											
NUH□□-FNS4-8	1/4 Female NPT	1/4 Female NPT	0.25 (6.4)	0.86	1.56 (39.7)	1.56 (39.7)	3.50 (88.9)	0.63 (16.0)	1.81 (46.0)	1.03 (26.2)	4.09 (104)		
NUH□□-NS8-8	1/2 Male NPT	1/2 Male NPT											
NUH□□-TS8-8-G	1/2" TS	1/2" TS											
NUH□□-MTS12-8-G	12 mm MTS	12 mm MTS											
NUH□□-MTS16-9-G	16 mm MTS	16 mm MTS	0.39 (10.0)	1.8	1.75 (44.5)	1.75 (44.5)	3.50 (88.9)	0.91 (23.0)	2.29 (58.2)	1.14 (28.9)	5.28 (134.1)		
NUH□□-MTB22-9-G	22 mm MTB	22 mm MTB											
NUH□□-FNS8-9	1/2 Female NPT	1/2 Female NPT										1.56 (39.7)	1.56 (39.7)

1. Connection type of "FITOK" means FITOK double ferrule tube fittings. When the connection type of valves is FITOK double ferrule tube fitting, the working pressures of the valves are related to the wall thickness of tubing applied. For specific working pressure of the valves, please refer to the allowable working pressures in FITOK Tubing catalog.
- 2.Connection type of "TS" means fractional tube socket weld. "MTS" means metric tube socket weld. "MTB" means metric tube butt weld. "
3. Sizes and types listed are standard. Other sizes and types are available upon request. For details, please contact FITOK Group or our authorized distributors.
4. Dimensions are shown with FITOK tube fitting nuts finger-tight. All dimensions are for reference only and are subject to change. For dimensions not shown above, please contact FITOK Group or our authorized distributors.

Ordering Number Description

NUSS - FNS6 - FL6 - 8WB - GM - ASF2

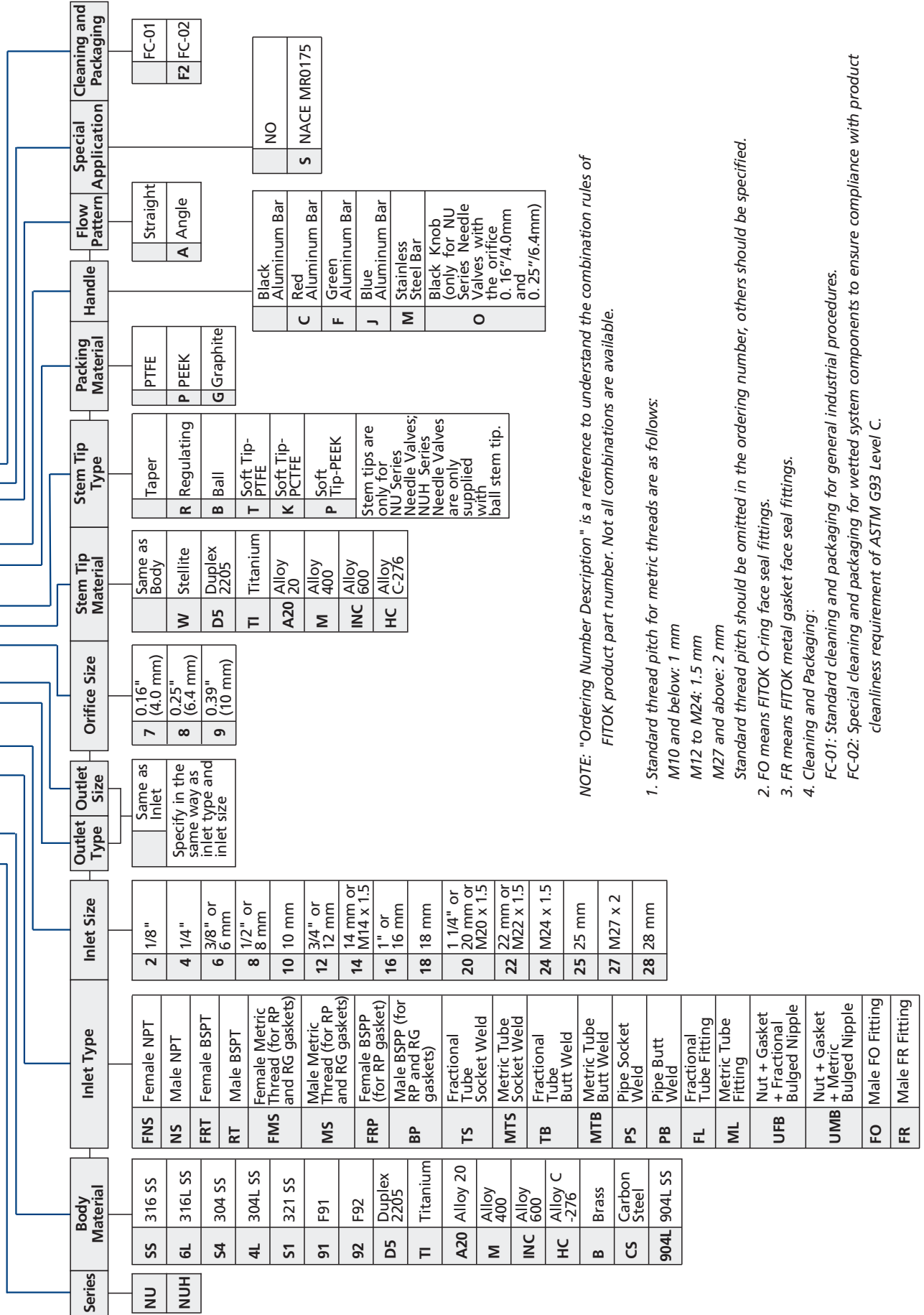

NOTE: "Ordering Number Description" is a reference to understand the combination rules of FITOK product part number. Not all combinations are available.

- Standard thread pitch for metric threads are as follows:
 M10 and below: 1 mm
 M12 to M24: 1.5 mm
 M27 and above: 2 mm
 Standard thread pitch should be omitted in the ordering number, others should be specified.
- FO means FITOK O-ring face seal fittings.
- FR means FITOK metal gasket face seal fittings.
- Cleaning and Packaging:
 FC-01: Standard cleaning and packaging for general industrial procedures.
 FC-02: Special cleaning and packaging for wetted system components to ensure compliance with product cleanliness requirement of ASTM G93 Level C.

Outside Screw and Yoke (OS&Y) Needle Valves

NY Series: Working pressure up to 6000 psig

Features

- ⦿ Cold drawn bar as body
- ⦿ Standard seat diameter 0.16" (4mm). Cv: 0.35 standard
- ⦿ Hardened stem threads prevent galling
- ⦿ Stem threads completely isolated from system media
- ⦿ Linear instead of rotary motion of the rising, non-rotating stem minimizes packing abrasion and reduces the friction between the seat and the tip
- ⦿ Externally adjustable gland, independent of spindle thread
- ⦿ Steady and durable fastening of the handle by double lock-pins
- ⦿ Bottom mounting available
- ⦿ Every valve leak tested with Nitrogen or compressed air at maximum allowable working pressure
- ⦿ Working pressure up to:
 - Stainless steel: 6000 psig (414 bar)
 - Alloy C-276: 6000 psig (414 bar)
 - Alloy 400: 5000 psig (345 bar)
- ⦿ Working temperature:
 - PTFE: -65°F to 450°F (-54°C to 232°C)
 - PEEK: -65°F to 500°F (-54°C to 260°C)
 - Graphite: -65°F to 1200°F (-54°C to 649°C)



Pressure vs. Temperature

NY Series

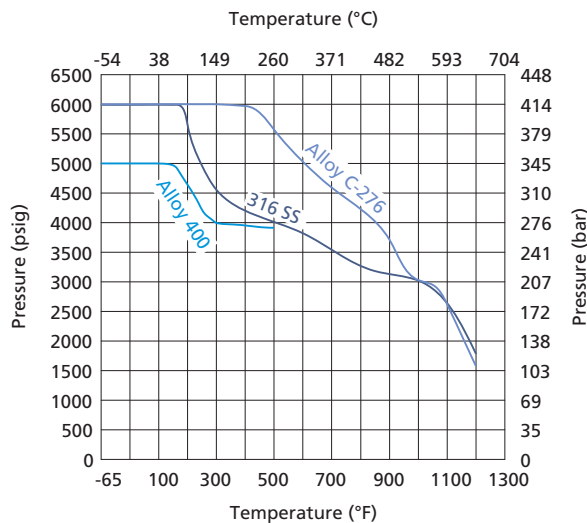

1. Graphs are based on graphite packing.
2. Contact FITOK Group or our authorized distributors for curve graph of other materials.

Standard Materials of Construction

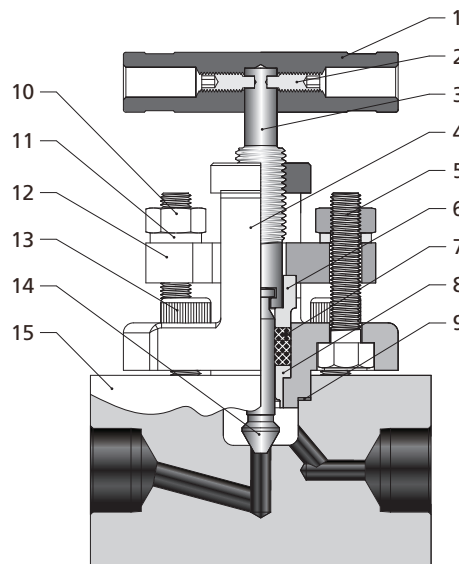

Item	Component	Valve Body Material
		316 SS
		Material Grade/ASTM Specification
1	Handle	Anodized aluminum or stainless steel
2	Set Screw	Galvanized carbon steel
3	Upper Stem	316 SS/A479
4	Yoke	316 SS/A182
5	Bolts	Stainless steel
6	Packing Washer	316 SS/A479
7	Packing	PTFE or PEEK or graphite
8	Packing Washer	316 SS/A479
9	Joint Seal	316 SS/A479
10	Nuts	Stainless steel
11	Gaskets	Stainless steel
12	Gland bridge	316 SS/A182
13	Bolts	Stainless steel
14	Lower Stem	Hardened 316 SS/A479
15	Body	316 SS/A479
	Lubricant	Molybdenum disulfide-based

Note: Contact FITOK Group or our authorized distributors for other materials.

Dimensions of NY Series

Basic Ordering Number	Connection Type and Size		Orifice in.(mm)	Cv	Dimensions, in.(mm)		
	Inlet	Outlet			A	B	C
NY□□-FNS4	1/4 Female NPT	1/4 Female NPT	0.16 (4.0)	0.35	2.69 (68.2)	1.50 (38.1)	4.04 (102.7)
NY□□-NS4	1/4 Male NPT	1/4 Male NPT			2.95 (75.0)		
NY□□-NS4-FNS4	1/4 Male NPT	1/4 Female NPT			2.72 (69.2)		
NY□□-FNS6	3/8 Female NPT	3/8 Female NPT			2.93 (75.0)		
NY□□-NS6	3/8 Male NPT	3/8 Male NPT			3.00 (76.2)		
NY□□-FNS8	1/2 Female NPT	1/2 Female NPT			3.27 (82.0)		
NY□□-NS8	1/2 Male NPT	1/2 Male NPT			3.00 (76.2)		
NY□□-NS8-FNS8	1/2 Male NPT	1/2 Female NPT			3.54 (89.8)		
NY□□-PS8-G	1/2 PS	1/2 PS			3.44 (87.4)		
NY□□-PB8-G	1/2 PB	1/2 PB			3.50 (88.9)		
NY□□-FL4	1/4" FITOK	1/4" FITOK			3.78 (96.0)		
NY□□-FL6	3/8" FITOK	3/8" FITOK			3.44 (87.4)		
NY□□-FL8	1/2" FITOK	1/2" FITOK			3.78 (96.0)		
NY□□-ML6	6 mm FITOK	6 mm FITOK			3.44 (87.4)		
NY□□-ML8	8 mm FITOK	8 mm FITOK	3.78 (96.0)				
NY□□-ML12	12 mm FITOK	12 mm FITOK					

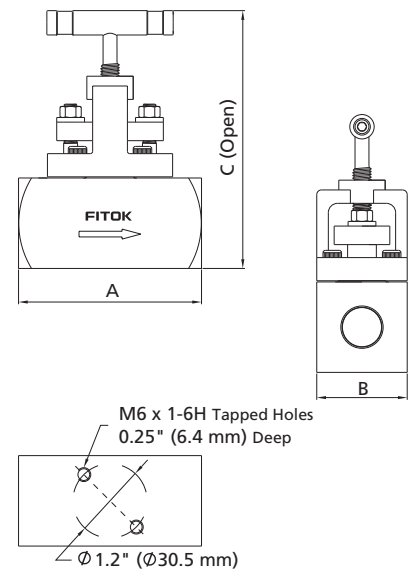

1. Connection type of "FITOK" means FITOK double ferrule tube fittings. When the connection type of valves is FITOK double ferrule tube fitting, the working pressures of the valves are related to the wall thickness of tubing applied. For specific working pressure of the valves, please refer to the allowable working pressures in FITOK Catalog Tubing.
2. Connection type of "PS" means pipe socket weld. "PB" means pipe butt weld.
3. Sizes and types listed are standard. Other sizes and types are available upon request. For details, please contact FITOK Group or our authorized distributors.
4. Dimensions are shown with FITOK tube fitting nuts finger-tight. All dimensions not shown above, please contact FITOK Group or our authorized distributors.

Ordering Number Description

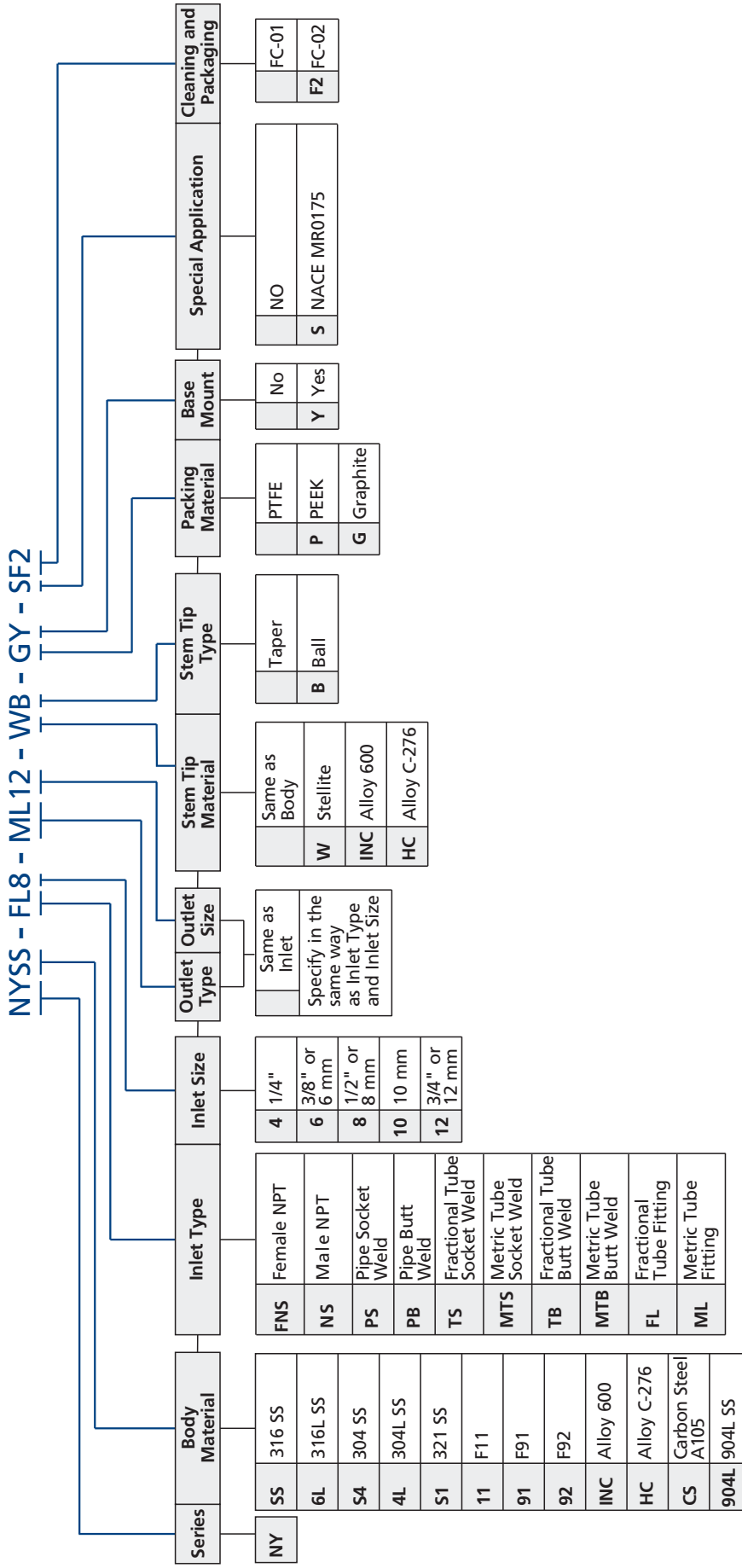

NOTE: "Ordering Number Description" is a reference to understand the combination rules of FITOK product part number. Not all combinations are available.

Cleaning and Packaging:

FC-01: Standard cleaning and packaging for general industrial procedures.

FC-02: Special cleaning and packaging for wetted system components to ensure compliance with product cleanliness requirement of ASTM G93 Level C.

Metering Valves

MS, MV, ML and MH Series



Needle Valves
Metering Valves

Features

MS Series

- ⦿ Working pressure up to: 2000 psig (138 bar)
- ⦿ Working temperature: -10°F to 400°F (-23°C to 204°C)
- ⦿ Orifice size: 0.032" (0.81 mm)
- ⦿ Max. flow coefficient (Cv): 0.004
- ⦿ Stem taper: 1°
- ⦿ Turns to open: 9 to 12
- ⦿ Shutoff service: not available
- ⦿ Variety of end connections
- ⦿ Panel mountable
- ⦿ Flow pattern: straight, angle, cross and double
- ⦿ Handle type: knurled, vernier and slotted
- ⦿ Variety of materials available for valve body



MV and ML Series

- ⦿ Working pressure up to: 1000 psig (69 bar)
- ⦿ Working temperature: -10°F to 400°F (-23°C to 204°C)
- ⦿ Max. flow coefficients (Cv):
 - MV series: 0.03
 - ML series: 0.15
- ⦿ Orifice sizes:
 - MV series: 0.056" (1.42 mm)
 - ML series: 0.128" (3.25 mm)
- ⦿ Stem taper:
 - MV series: 3°
 - ML series: 6.5°
- ⦿ Turns to open:
 - MV series: 8 to 10
 - ML series: 10 to 11
- ⦿ Shutoff service:
 - MV series: not available
 - ML series: available
- ⦿ Variety of end connections
- ⦿ Panel mountable
- ⦿ Flow pattern: straight, angle, cross (MV Series) and double (MV Series)
- ⦿ Handle type:
 - MV series: knurled, vernier and slotted
 - ML series: round and vernier
- ⦿ Variety of materials available for valve body



MH Series

- ⦿ Working pressure up to: 5000 psig (345 bar)
- ⦿ Working temperature: -65°F to 850°F (-54°C to 454°C)
- ⦿ Orifice size: 0.062" (1.6 mm)
- ⦿ Max. flow coefficient(Cv): 0.04
- ⦿ Stem taper: 2°
- ⦿ Shutoff service: available
- ⦿ Variety of end connections
- ⦿ Turns to open: 9 to 10
- ⦿ Panel mountable
- ⦿ Flow pattern: straight and angle
- ⦿ Handle type: round circular and vernier
- ⦿ Variety of materials available for valve body



Pressure vs. Temperature

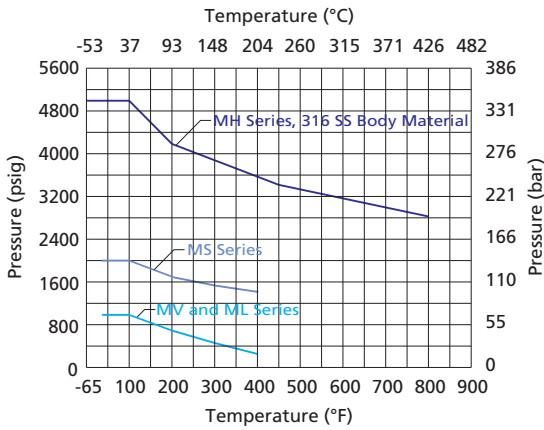

1. Graphs are based on Fluorocarbon and Graphite (for MH Series).
2. Contact FITOK Group or our authorized distributors for curve graph of other materials.

Temperature Ranges for Different seal Materials

Seal Material	Temperature Range °F (°C)
O-Ring (for MS, MV, ML Series)	
Buna N (NBR)	-10 to 212 (-23 to 100)
Ethylene Propylene (EPDM)	-10 to 300 (-23 to 148)
Fluorocarbon (FKM)	-10 to 400 (-23 to 204)
Kalrez (FFKM)	-10 to 527 (-23 to 275)
Neoprene (CR)	-10 to 250 (-23 to 121)
Stem Packing (for MH Series)	
PTFE	-65 to 450 (-54 to 232)
Graphite	-65 to 850 (-54 to 454)

Standard Materials of Construction

MS Series

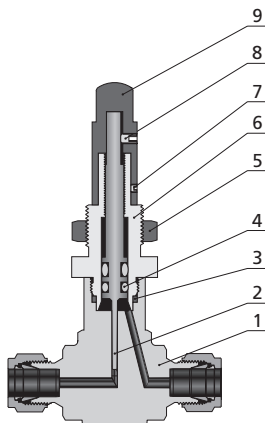

Component		Valve Body Material Grade/ASTM Specification	
		316 SS	Brass
1	Body	316 SS/A182	Silver-mist chrome-plated C37700/B283
2	Stem	316 SS/A479	
3	Body Seal	Fluorocarbon FKM	
4	O-ring	Fluorocarbon FKM	
5	Panel Mount Nut	Stainless steel	Silver-mist chrome-plated C36000/B16
6	Bonnet	316 SS/A479	Silver-mist chrome-plated C36000/B16
7	Lock Screw	Stainless steel	
8	Handle Screw	Stainless steel	
9	Handle	316 SS/A276	Silver-mist chrome-plated C36000/B16

MV Series

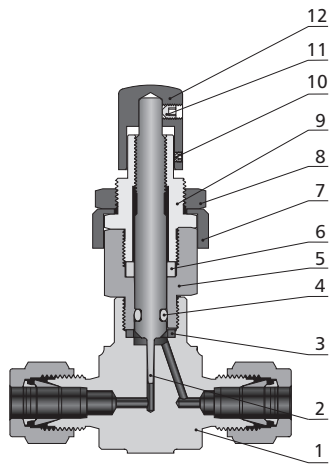

Component		Valve Body Material Grade/ASTM Specification	
		316 SS	Brass
1	Body	316 SS/A182	Silver-mist chrome-plated C37700/B283
2	Stem	316 SS/A479	
3	Body Seal	Fluorocarbon FKM	
4	O-ring	Fluorocarbon FKM	
5	Body Extension	316 SS/A479	Silver-mist chrome-plated C36000/B16
6	Stem Guide Ring	PTFE/D1710	
7	Bonnet Sleeve	Stainless steel	
8	Panel Mount Nut	316 SS/A276	Silver-mist chrome-plated C36000/B16
9	Bonnet	316 SS/A479	Silver-mist chrome-plated C36000/B16
10	Lock Screw	Stainless steel	
11	Handle Screw	Stainless steel	
12	Handle	316 SS/A276	Silver-mist chrome-plated C36000/B16

ML Series

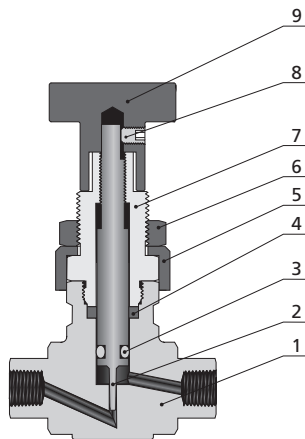

Component		Valve Body Material Grade/ASTM Specification	
		316 SS	Brass
1	Body	316 SS/A182	Silver-mist chrome-plated C37700/B283
2	Stem	Hardened 316 SS/A479	
3	O-ring	Fluorocarbon FKM	
4	Stem Guide Ring	PTFE/D1710	
5	Bonnet Sleeve	Stainless steel	
6	Panel Mount Nut	316 SS/A276	Silver-mist chrome-plated C36000/B16
7	Bonnet	316 SS/A479	Silver-mist chrome-plated C36000/B16
8	Handle Screw	Stainless steel	
9	Handle	Anodized aluminium	

1. Lubricants: Silicone-based

2. Contact FITOK Group or our authorized distributors for other materials.

MH Series

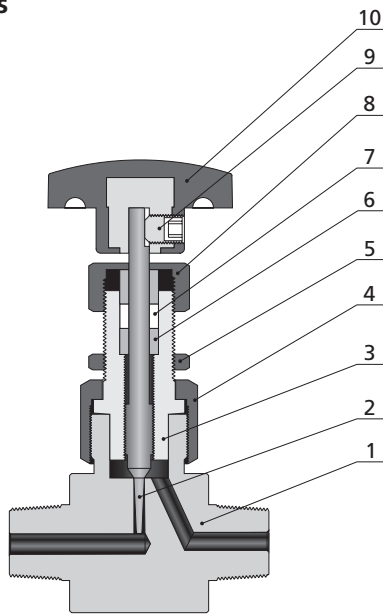

Component		Material Grade/ASTM Specification
1	Body	316 SS/A479
2	Stem	440C SS/A276
3	Bonnet	316 SS/A479
4	Union Nut	316 SS/A276
5	Panel Mount Nut	Stainless steel
6	Packing Gland	316 SS/A276
7	Packing	PTFE/D1710
8	Union Nut	316 SS/A276
9	Handle Screw	Stainless steel
10	Handle	Nylon

Lubricant:Silicone-based

Needle Valves
Metering Valves

Flow Data in full open position at 70°F (20°C)

Pressure Drop to Atmosphere psig (bar)	MS Series (CV: 0.004)		MV Series (CV: 0.03)		ML Series (CV: 0.15)		MH Series (CV: 0.04)	
	Air Flow std ft ³ /min (std L/min)	Water Flow U.S. gal/min (L/min)	Air Flow std ft ³ /min (std L/min)	Water Flow U.S. gal/min (L/min)	Air Flow std ft ³ /min (std L/min)	Water Flow U.S. gal/min (L/min)	Air Flow std ft ³ /min (std L/min)	Water Flow U.S. gal/min (L/min)
10 (0.69)	0.04 (1.1)	0.01 (0.03)	0.33 (9.3)	0.09 (0.34)	2.00 (56.6)	0.51 (1.90)	0.45 (12.7)	0.12 (0.45)
50 (3.45)	0.10 (2.8)	0.02 (0.07)	0.90 (25.4)	0.21 (0.79)	6.40 (181)	1.20 (4.50)	1.20 (33.9)	0.28 (1.00)
100 (6.90)	0.20 (5.6)	0.04 (0.15)	1.50 (42.4)	0.30 (1.10)	11.40 (323)	1.70 (6.40)	2.10 (59.4)	0.40 (1.50)

Flow Coefficient at Turns to Open

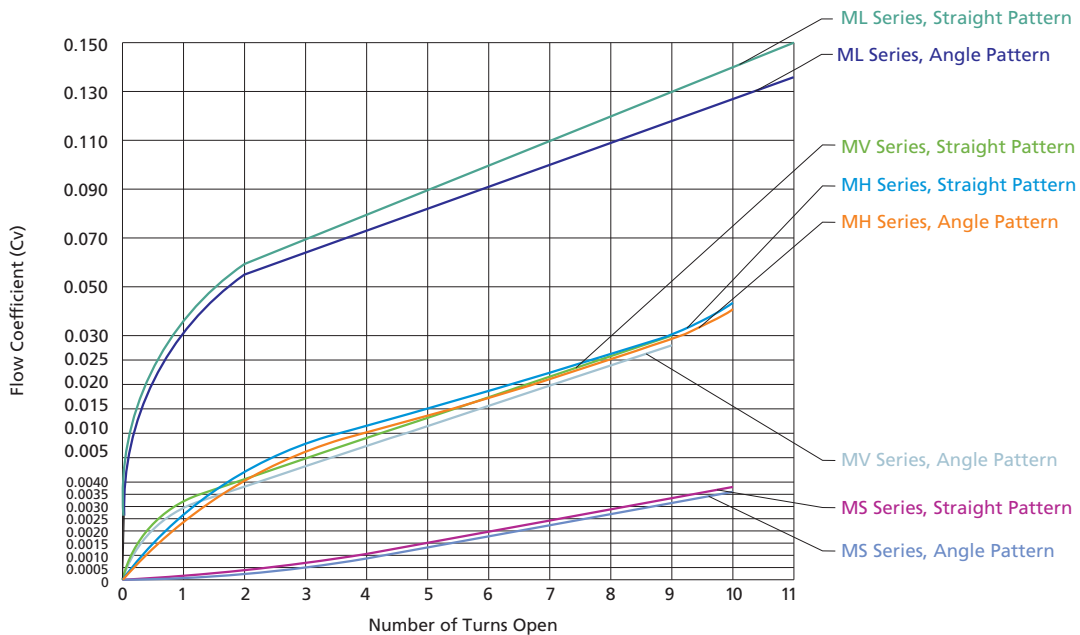

Dimensions

MS Series

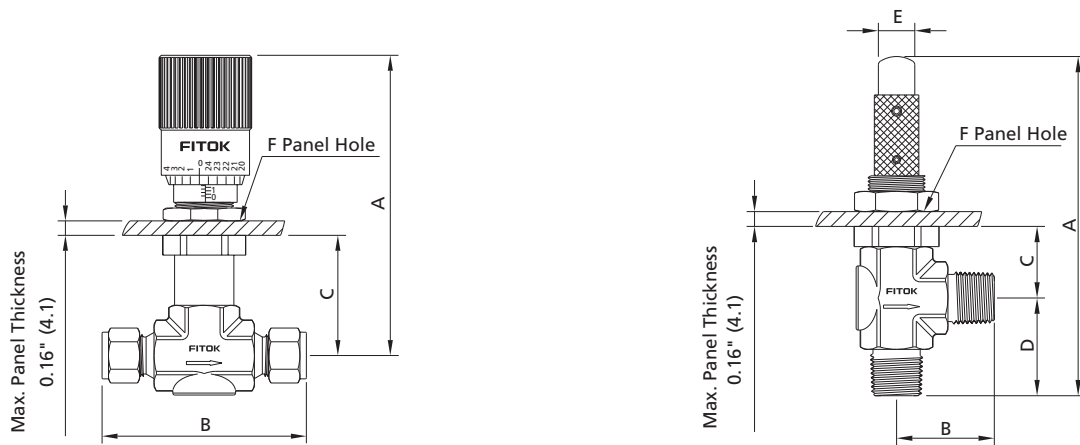

Basic Ordering Number	Connection Type and Size		Dimensions, in. (mm)					
	Inlet	Outlet	A	B	C	D	E	F
Straight Pattern								
MS□□-FL1-	1/16" FITOK	1/16" FITOK	2.34 (59.4)	1.56 (39.6)	0.92 (23.4)	—	0.38 (9.6)	0.45 (11.4)
MS□□-FL2-	1/8" FITOK	1/8" FITOK						
MS□□-FL4-	1/4" FITOK	1/4" FITOK						
MS□□-ML3-	3 mm FITOK	3 mm FITOK						
MS□□-ML6-	6 mm FITOK	6 mm FITOK						
MS□□-FR4-	1/4 Male FR	1/4 Male FR	2.06 (52.3)					
Angle Pattern								
MS□□-FL1-	1/16" FITOK	1/16" FITOK	2.96 (75.2)	0.81 (20.6)	0.92 (23.4)	0.81 (20.6)	0.38 (9.6)	0.45 (11.4)
MS□□-FL2-	1/8" FITOK	1/8" FITOK	3.07 (78.0)	0.98 (24.9)				
MS□□-FL4-	1/4" FITOK	1/4" FITOK	3.11 (79.0)	1.02 (25.9)				
MS□□-ML3-	3 mm FITOK	3 mm FITOK	3.07 (78.0)	0.98 (24.9)		0.98 (24.9)		
MS□□-FNS2-	1/8 Female NPT	1/8 Female NPT						

MV and ML Series

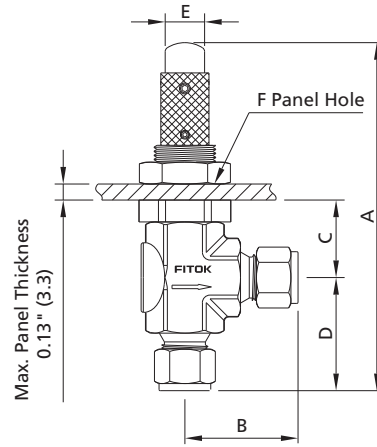
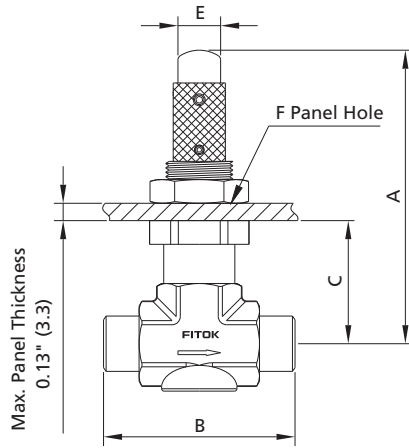

Basic Ordering Number	Connection Type and Size		Dimensions, in. (mm)					
	Inlet	Outlet	A	B	C	D	E	F

Straight Pattern

MV□□-FL2-	1/8" FITOK	1/8" FITOK	2.64 (67.1)	2.02 (51.3)	1.52 (38.5)	—	0.50 (12.7)	0.58 (14.7)
MV□□-FL4-	1/4" FITOK	1/4" FITOK		2.20 (55.9)				
MV□□-ML3-	3 mm FITOK	3 mm FITOK		2.02 (51.3)				
MV□□-ML6-	6 mm FITOK	6 mm FITOK		2.20 (55.9)				
MV□□-NS2-	1/8 Male NPT	1/8 Male NPT		1.60 (40.6)				
MV□□-NS4-	1/4 Male NPT	1/4 Male NPT		1.96 (49.8)				
MV□□-FNS2-	1/8 Female NPT	1/8 Female NPT		1.94 (49.3)				
MV□□-FR4-	1/4 Male FR	1/4 Male FR		2.06 (52.3)				

Angle Pattern

MV□□-FL2-	1/8" FITOK	1/8" FITOK	3.65 (92.8)	1.01 (25.7)	1.07 (27.2)	1.01 (25.7)	0.50 (12.7)	0.58 (14.7)
MV□□-FL4-	1/4" FITOK	1/4" FITOK	3.74 (95.0)	1.10 (27.9)		1.10 (27.9)		
MV□□-ML3-	3 mm FITOK	3 mm FITOK	3.65 (92.8)	1.01 (25.7)		1.01 (25.7)		
MV□□-ML6-	6 mm FITOK	6 mm FITOK	3.74 (95.0)	1.10 (27.9)		1.10 (27.9)		
MV□□-NS2-	1/8 Male NPT	1/8 Male NPT	3.44 (87.4)	0.80 (20.3)		0.80 (20.3)		
MV□□-NS4-	1/4 Male NPT	1/4 Male NPT	3.62 (92.0)	0.98 (24.9)		0.98 (24.9)		
MV□□-FNS2-	1/8 Female NPT	1/8 Female NPT	3.61 (91.7)	0.97 (24.6)		0.97 (24.6)		
MV□□-FR4-	1/4 Male FR	1/4 Male FR						

Basic Ordering Number	Connection Type and Size		Dimensions, in. (mm)					
	Inlet	Outlet	A	B	C	D	E	F

Straight Pattern

ML□□-FL4-	1/4" FITOK	1/4" FITOK	2.72 (69.1)	2.34 (59.4)	1.26 (32.0)	—	1.13 (28.7)	0.58 (14.7)
ML□□-FL6-	3/8" FITOK	3/8" FITOK		2.46 (62.5)				
ML□□-ML6-	6 mm FITOK	6 mm FITOK		2.34 (59.4)				
ML□□-NS4-	1/4 Male NPT	1/4 Male NPT		2.00 (50.8)				

Angle Pattern

ML□□-FL4-	1/4" FITOK	1/4" FITOK	3.89 (98.8)	1.17 (29.7)	1.26 (32.0)	1.17 (29.7)	1.13 (28.7)	0.58 (14.7)
ML□□-ML6-	6 mm FITOK	6 mm FITOK						

B-110 Metering Valves

MH Series

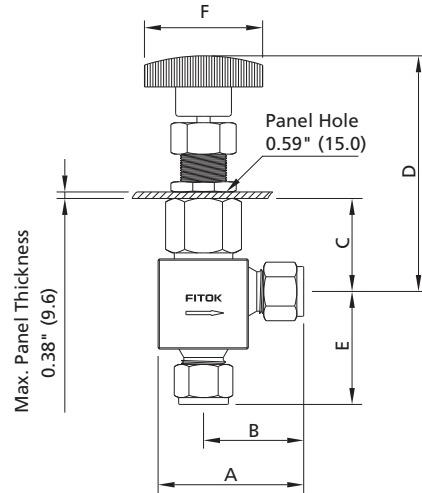
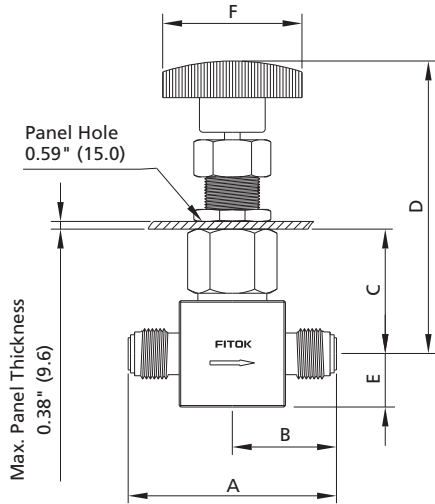

Basic Ordering Number	Connection Type and Size		Dimensions, in. (mm)					
	Inlet	Outlet	A	B	C	D	E	F
Straight Pattern								
MH□□-FL4-	1/4" FITOK	1/4" FITOK	2.40 (61.0)	1.20 (30.5)	1.09 (27.7)	3.86 (98.0)	0.38 (9.6)	1.38 (35.1)
MH□□-ML6-	6 mm FITOK	6 mm FITOK					0.40 (10.1)	
MH□□-FNS2-	1/8 Female NPT	1/8 Female NPT	2.00 (50.8)	1.00 (25.4)				
MH□□-FNS4-	1/4 Female NPT	1/4 Female NPT	2.06 (52.3)	1.03 (26.2)				
Angle Pattern								
MH□□-FL4-	1/4" FITOK	1/4" FITOK	1.54 (39.1)	1.16 (29.5)	1.09 (27.7)	3.86 (98.0)	1.48 (37.6)	1.38 (35.1)
MH□□-ML6-	6 mm FITOK	6 mm FITOK					1.00 (25.4)	
MH□□-FNS2-	1/8 Female NPT	1/8 Female NPT	1.28 (32.5)	0.91 (23.1)				
MH□□-FNS4-	1/4 Female NPT	1/4 Female NPT						

Optional Handles

Slotted Handle

- ⦿ Flow setting adjustment is available with a screwdriver
- ⦿ Ideal for installation where handle is difficult to access
- ⦿ Available for MS and MV series

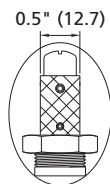

Vernier Handle

- ⦿ Precise graduated aluminum alloy handle
- ⦿ Repeatable flow setting
- ⦿ Adjustment accurate to 1/25 turn (1/1000 of an inch)
- ⦿ Available for all series

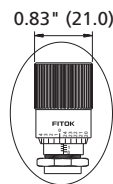

Optional Patterns

Cross Pattern

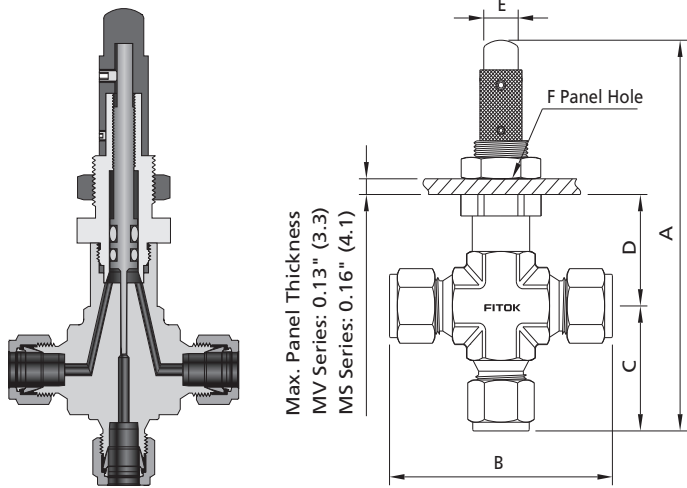

Double Pattern

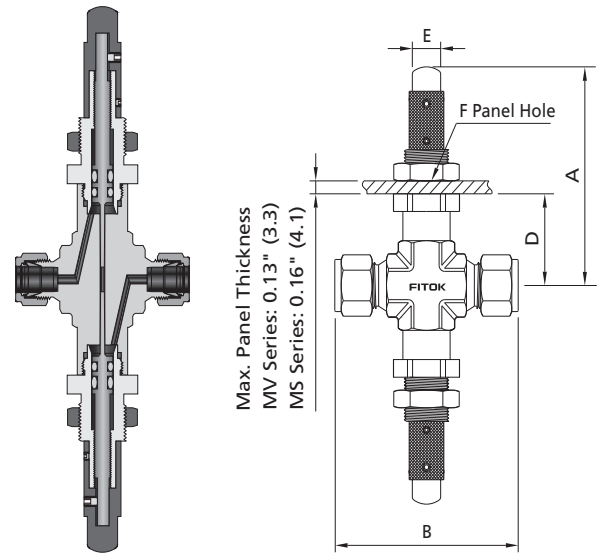

1. Fluid flows between side ports around stem in any stem position.
2. Fluid flows through branch port can be metered in both directions.

Inlet valve handle can be set and locked at desired maximum flow, outlet valve handle can be used for fine flow control up to the preset maximum of the inlet valve.

Basic Ordering Number	Connection Type and Size		Dimensions, in. (mm)					
	Inlet	Outlet	A	B	C	D	E	F
Cross Pattern								
MS□□-FL2-	1/8" FITOK	1/8" FITOK	3.32 (84.3)	1.96 (49.8)	0.98 (24.9)	0.92 (23.4)	0.38 (9.6)	0.45 (11.4)
MS□□-ML3-	3 mm FITOK	3 mm FITOK						
Double Pattern								
MS□□-FL2-	1/8" FITOK	1/8" FITOK	2.41 (61.2)	1.90 (48.3)	—	0.99 (25.2)	0.38 (9.6)	0.45 (11.4)
MS□□-ML3-	3 mm FITOK	3 mm FITOK						
Cross Pattern								
MV□□-FL4-	1/4" FITOK	1/4" FITOK	3.74 (95.0)	2.20 (55.9)	1.10 (27.9)	1.52 (38.5)	0.50 (12.7)	0.58 (14.7)
MV□□-ML6-	6 mm FITOK	6 mm FITOK						
Double Pattern								
MV□□-FL4-	1/4" FITOK	1/4" FITOK	2.62 (67.1)	2.20 (55.9)	—	1.52 (38.5)	0.50 (12.7)	0.58 (14.7)
MV□□-ML6-	6 mm FITOK	6 mm FITOK						

1. FITOK means FITOK double ferrule tube fittings, FR means metal gasket seal fittings.
2. Sizes and types listed are standard. Other sizes and types are available upon request. For special sizes and types, refer to the ordering information.
3. Dimensions are shown with FITOK nuts finger-tightened. All dimensions are for reference only and are subject to change. For dimensions not shown above, please contact FITOK Group or our authorized distributors.

Ordering Number Description

MVSS – FL4 – ML6 – EVJ – ASF2

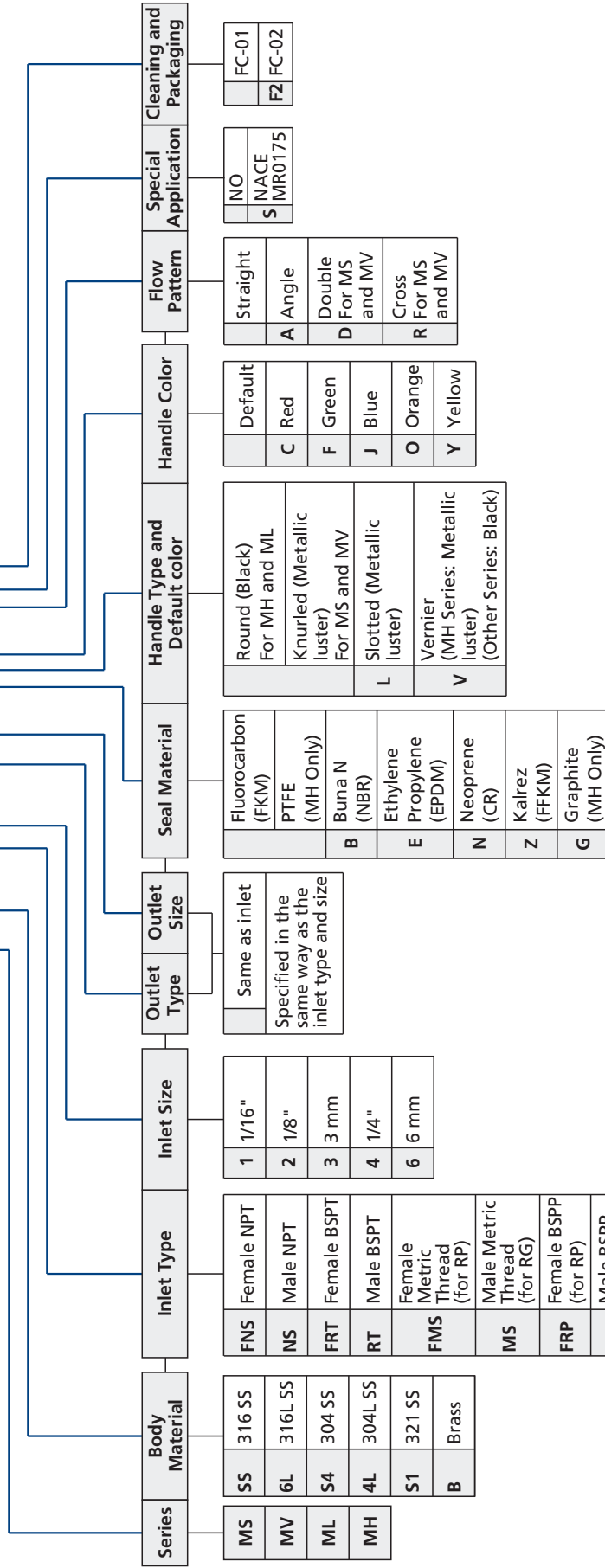

Series	Body Material	Inlet Type	Inlet Size	Outlet Type	Outlet Size	Seal Material	Handle Type and Default color	Handle Color	Flow Pattern	Special Application	Cleaning and Packaging
MS	316 SS	FNS Female NPT	1 1/16"	Same as inlet	Specified in the same way as the inlet type and size	Fluorocarbon (FKM)	Round (Black) For MH and ML	C Red	Straight	NO	FC-01
MV	316L SS	NS Male NPT	2 1/8"								
ML	304 SS	FRT Female BSPT	3 3 mm	Specified in the same way as the inlet type and size		Buna N (NBR)	Knurled (Metallic luster) For MS and MV	F Green	A Angle	S MR0175	F2
MH	304L SS	RT Male BSPT	4 1/4"								
S1	321 SS	FMS Female Metric Thread (for RP)	6 6 mm								
B	Brass	MS Male Metric Thread (for RG)									
		FRP Female BSPP (for RP)									
		BP Male BSPP (for RG)					L Slotted (Metallic luster)	J Blue	D Double For MS and MV		
		FL Fractional Tube Fitting					V Vernier (MH Series; Metallic luster) (Other Series: Black)	O Orange	R Cross For MS and MV		
		ML Metric Tube Fitting						Y Yellow			
		FO FO Fitting									
		FR Male FR Fitting									

Note: "Ordering Number Description" is a reference to understand the combination rules of FITOK product part number. Not all combinations are available.

1. *Cleaning and Packaging:*
 FC-01: Standard cleaning and packaging for general industrial procedures.
 FC-02: Special cleaning and packaging for wetted system components to ensure compliance with product cleaning requirement of ASTM G93 Level C.

Bellows-sealed Valves

SW and SU Series



Bellows-sealed
Valves

Contents

Bellows-sealed Valves

SW Series



B-125

Bellows-sealed Valves

SU Series



B-131

Bellows-sealed Valves

SW Series

Features

- ⦿ Working pressure up to: 1000 psig (69.0 bar)
- ⦿ Working temperature: -20°F to 842°F (-28°C to 450°C)
- ⦿ Variety of end connections
- ⦿ Body material: 316 SS, brass
- ⦿ Hydraulic-formed multilayer bellows for longer cycle life
- ⦿ Nonrotating stem tip eliminates galling within the seat area
- ⦿ Externally pressurized bellows design for maximum strength
- ⦿ Strictly controlled bellows stroke to improve safety and cycle life
- ⦿ Replaceable bellows and stem tip assembly
- ⦿ Regulating, conical and spherical stem tips available
- ⦿ Handle color options are available
- ⦿ Panel and bottom mounting available
- ⦿ Every FITOK bellows-sealed valve leak tested with helium at the seat, envelope and all seals (maximum allowable leak rate: 4×10^{-9} std cm³/s)



Pressure vs. Temperature

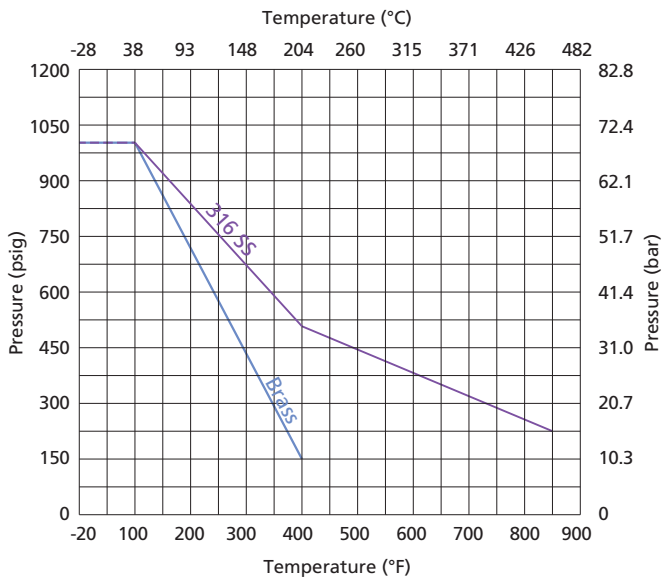

200°F (93°C) max. with PCTFE stem tip (soft tip).

Flow Coefficient vs. Turns Open

Regulating Stem

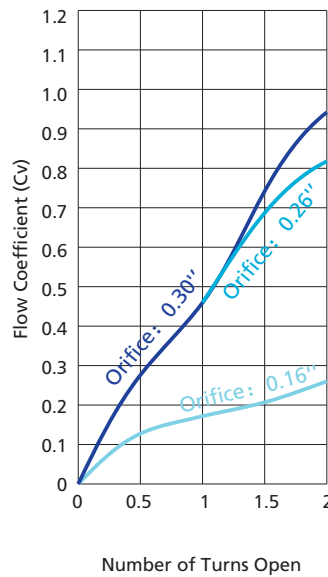

Standard Materials of Construction

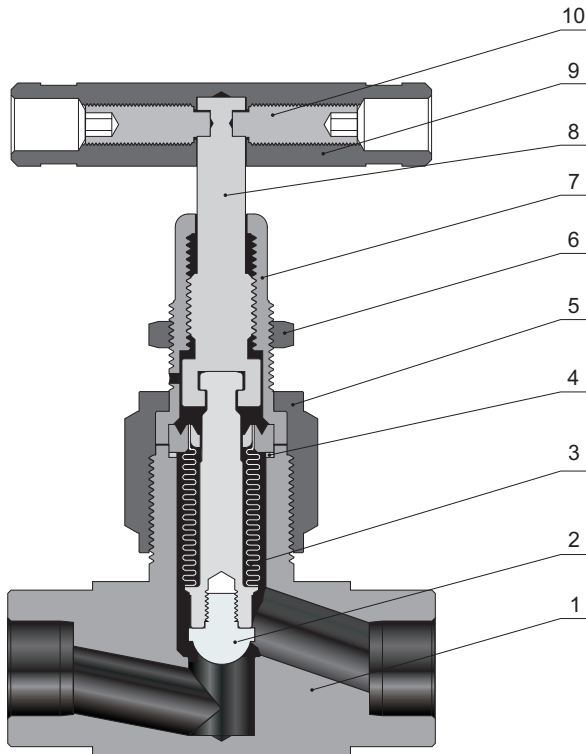

Tip Types

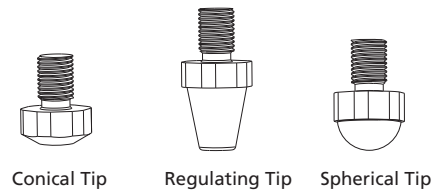

Component		Valve Body Material Grade/ASTM Specification	
		316 SS	Brass
1	Body	316 SS/A182	Brass/B283
2	Stem Tip	Regulating	316 SS/A479 or Stellite
		Conical	PCTFE/D1430 or 316 SS/A479 or Stellite
		Spherical	Stellite
3	Bellows	316L SS/A240	
	Stem	316 SS/A479	
	Weld Ring	316 SS/A479	
4	Gasket	Silver-plated 316 SS/A269	
5	Bonnet Nut	316 SS/A479	Brass/B16
6	Panel Mount Nut	Stainless steel	Brass/B16
7	Bonnet	316 SS/A479	Brass/B16
8	Actuator	316 SS/A479	316 SS/A479
9	Handle	6061/B211 or stainless steel	
10	Set Screws	Galvanized carbon steel	
Non-wetted Lubricant		Molybdenum disulfide	

Contact FITOK Group or our authorized distributors for valves of other materials.

Dimensions

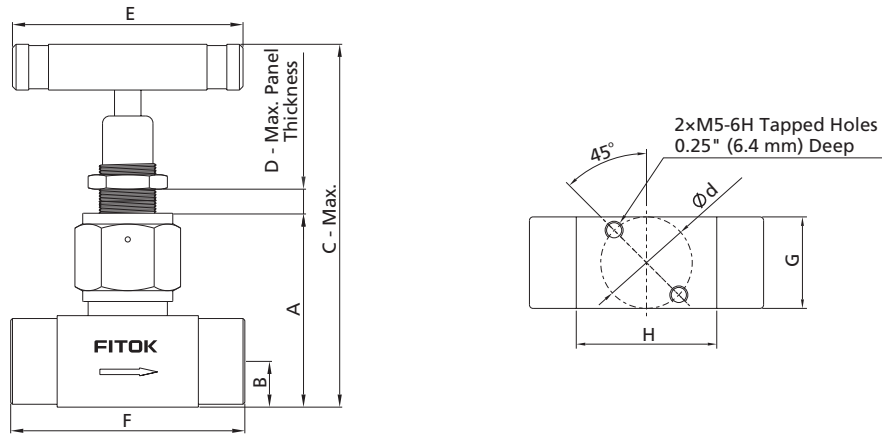

Basic Ordering Number	Connection Type and Size		Orifice in. (mm)	Cv	Dimensions, in. (mm)								
	Inlet	Outlet			A	B	C	D	E	F	G	H	Ød
SW□□-FL4-2-	1/4" FITOK	1/4" FITOK	0.16 (4.1)	0.36	2.16 (54.8)	0.54 (13.7)	4.05 (102.8)	0.39 (10.0)	2.50 (63.5)	2.46 (62.5)	1.00 (25.4)	1.06 (26.9)	1.00 (25.4)
SW□□-FL6-3-	3/8" FITOK	3/8" FITOK	0.26 (6.6)	0.85	2.20 (55.8)	0.54 (13.7)	4.09 (103.8)	0.39 (10.0)	2.50 (63.5)	3.09 (78.5)	1.10 (25.4)	1.57 (39.9)	1.00 (25.4)
SW□□-FL8-5-	1/2" FITOK	1/2" FITOK	0.30 (7.6)	1.20	2.16 (54.8)	0.54 (13.7)	4.05 (102.8)	0.39 (10.0)	2.50 (63.5)	3.30 (83.8)	1.13 (25.4)	1.57 (40.0)	1.00 (25.4)
SW□□-ML6-2-	6 mm FITOK	6 mm FITOK	0.16 (4.1)	0.36	2.16 (54.8)	0.54 (13.7)	4.05 (102.8)	0.39 (10.0)	2.50 (63.5)	2.46 (62.5)	1.00 (25.4)	1.07 (27.1)	1.00 (25.4)
SW□□-ML10-4-	10 mm FITOK	10 mm FITOK	0.28 (7.1)	1.00	2.20 (55.8)	0.54 (13.7)	4.09 (103.8)	0.39 (10.0)	2.50 (63.5)	3.11 (79.0)	1.00 (25.4)	1.57 (39.8)	1.00 (25.4)
SW□□-ML12-5-	12 mm FITOK	12 mm FITOK	0.30 (7.6)	1.20	2.20 (55.8)	0.54 (13.7)	4.09 (103.8)	0.39 (10.0)	2.50 (63.5)	3.30 (83.8)	1.00 (25.4)	1.57 (39.8)	1.00 (25.4)
SW□□-TS4-2-	1/4" TS	1/4" TS	0.16 (4.1)	0.36	2.20 (55.8)	0.54 (13.7)	4.09 (103.8)	0.39 (10.0)	2.50 (63.5)	1.68 (42.7)	1.00 (25.4)	1.00 (25.4)	1.00 (25.4)
SW□□-TS6-4-	3/8" TS	3/8" TS	0.28 (7.1)	1.00	2.20 (55.8)	0.54 (13.7)	4.09 (103.8)	0.39 (10.0)	2.50 (63.5)	2.27 (57.7)	1.00 (25.4)	1.51 (38.4)	1.00 (25.4)
SW□□-TS8-5-	1/2" TS	1/2" TS	0.30 (7.6)	1.20	2.20 (55.8)	0.54 (13.7)	4.09 (103.8)	0.39 (10.0)	2.50 (63.5)	2.27 (57.7)	1.00 (25.4)	1.25 (31.7)	1.00 (25.4)
SW□□-TB8-4-	1/2" TB	1/2" TB	0.28 (7.1)	1.00	2.20 (55.8)	0.54 (13.7)	4.09 (103.8)	0.39 (10.0)	2.50 (63.5)	2.27 (57.7)	1.00 (25.4)	1.51 (38.4)	1.00 (25.4)
SW□□-FFR4-2-	1/4" Female FR	1/4" Female FR	0.16 (4.1)	0.36	2.16 (54.8)	0.54 (13.7)	4.05 (102.8)	0.39 (10.0)	2.50 (63.5)	2.76 (70.1)	1.00 (25.4)	1.02 (25.8)	1.00 (25.4)
SW□□-FFR8-5-	1/2" Female FR	1/2" Female FR	0.30 (7.6)	1.20	2.20 (55.8)	0.54 (13.7)	4.09 (103.8)	0.39 (10.0)	2.50 (63.5)	3.12 (79.2)	1.00 (25.4)	1.25 (31.75)	1.00 (25.4)
SW□□-FR4-2-	1/4" Male FR	1/4" Male FR	0.16 (4.1)	0.36	2.16 (54.8)	0.54 (13.7)	4.05 (102.8)	0.39 (10.0)	2.50 (63.5)	2.24 (56.9)	1.00 (25.4)	1.00 (25.4)	1.00 (25.4)
SW□□-FR8-5-	1/2" Male FR	1/2" Male FR	0.30 (7.6)	1.20	2.20 (55.8)	0.54 (13.7)	4.09 (103.8)	0.39 (10.0)	2.50 (63.5)	3.00 (76.2)	1.13 (28.7)	1.50 (38.1)	1.00 (25.4)

1. FITOK means FITOK double ferrule tube fittings, FR means metal gasket seal fittings, TS means fractional tube socket weld, TB means fractional tube butt weld.
2. Dimensions are shown with FITOK nuts finger-tightened. All dimensions are for reference only and are subject to change. For dimensions not shown above, please contact FITOK Group or our authorized distributors.
3. Sizes and types listed are standard. Other sizes and types are available upon request. For special sizes and types, please contact FITOK Group or our authorized distributors.

Pneumatic Actuators



Features

- ⦿ Low actuation pressure
- ⦿ Opens and closes quickly and reliably
- ⦿ Rotatable port for normally closed actuators allows easy installation
- ⦿ Normally open actuators black capped for identification

Actuation Modes

- ⦿ Normally closed—air opens, spring closes
- ⦿ Normally open—air closes, spring opens

Technical Data

Actuator Type	Actuator Pressure Rating psig (bar)	Valve and Actuator Working Temperature °F (°C)	Valve Working Pressure psig (bar)
Normally Closed	65.3~79.8 (4.5~5.5)	-20~200 (-28~93)	10.0 (145)
Normally Open	72.5~87.0 (5.0~6.0)		34.4(500)

Materials of Construction

Component	Material
Housing	Anodized Aluminium
Stem Tip	PCTFE

For valve components, refer to "Standard Materials of Construction" on page B-126.

Dimensions

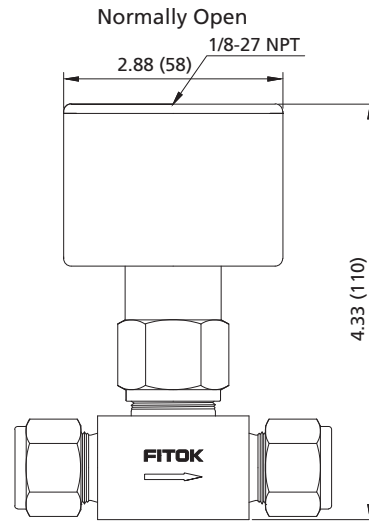
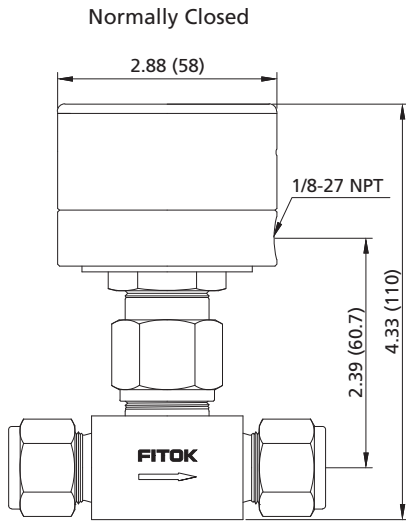

Basic Ordering Number	CV
SW□□-□□-2-KN-LC/LO	0.36
SW□□-□□-3-KN-LC/LO	0.85
SW□□-□□-5-KN-LC/LO	1.0

LC designates normally closed models; LO designates normally open models.

Ordering Number Description

SWSS – FL8 – ML10 – 5 – WR – B – BW – SF2

Valves
Bellows-sealed

Series	Body Material	Inlet Type	Inlet Size	Outlet Type	Outlet Size	Orifice Size	Stem Tip Material and Type	Actuator	Body-to-Bellows Seal	Special Application	Cleaning and Packaging							
SW	SS	Fractional Tube Socket Weld	2 1/8"	Same as Inlet	2 0.16" (4.1 mm)	2	Stellite Spherical	Green Aluminum Bar	NO	FC-01	FC-02							
	6L	Metric Tube Socket Weld	4 1/4"				Specified in the same way as Inlet type and size	3 0.26" (6.6 mm)				3	Stainless Steel Regulating	B Black Aluminum Bar	S NACE MR0175	F2		
	S4	Fractional Tube Butt Weld	6 3/8" or 6 mm	KN PCTFE Conical	C Red Aluminum Bar	4 0.28" (7.1 mm)			4	Gasket Seal								
	4L	Metric Tube Butt Weld	8 1/2" or 8 mm								WR Stellite Regulating		J Blue Aluminum Bar	5 0.31" (7.6 mm)			5	Welded Seal
	B	Pipe Socket Weld	10 10 mm															
		Pipe Butt Weld	12 3/4" or 12 mm	WN Stellite Conical	O Black nylon Knob	Only applicable to valves with orifice size of 0.16" (4.1mm), PCTFE conical tip and max. working pressure up to 100 psig (6.9 bar).												
		Fractional Tube Fitting	14 14 mm or M14				T Toggle handle	LC Normally Closed Pneumatic Actuator										
		Metric Tube Fitting	16 1" or 16 mm	LO Normally Open Pneumatic Actuator														
		Nut+Gasket+Fractional Bulge Nipple	18 18 mm															
		Nut+Gasket+Metric Bulge Nipple	20 20 mm															
		Female FR Fitting																
		Male FR Fitting																

Note: "Ordering Number Description" is a reference to understand the combination rules of FITOK product part number. Not all combinations are available.

1. Cleaning and Packaging:

FC-01: Standard cleaning and packaging for general industrial procedures.

FC-02: Special cleaning and packaging for wetted system components to ensure compliance with product cleanliness requirement of ASTM G93 Level C.

Bellows-sealed Valves

SU Series

Features

- Working pressure up to: 2500 psig (172 bar)
- Working temperature: -20°F to 842°F (-28°C to 450°C)
- Variety of end connections
- 316 SS body material
- Upper packing provides secondary containment system above the bellows
- Hydraulic-formed multilayer bellows for longer cycle life
- Nonrotating stem tip eliminates galling within the seat area
- Strictly controlled bellows stroke to improve safety and cycle life
- Replaceable bellows and stem tip assembly
- Regulating, conical, and spherical stem tips available
- Panel and bottom mounting available
- Double lock-pins enable steady and durable fastening of the handle
- Handle color options are available
- Every FITOK bellows-sealed valve leak tested with helium at the seat, envelope and all seals (maximum allowable leak rate : 4×10^{-9} std cm³/s)



Pressure vs. Temperature

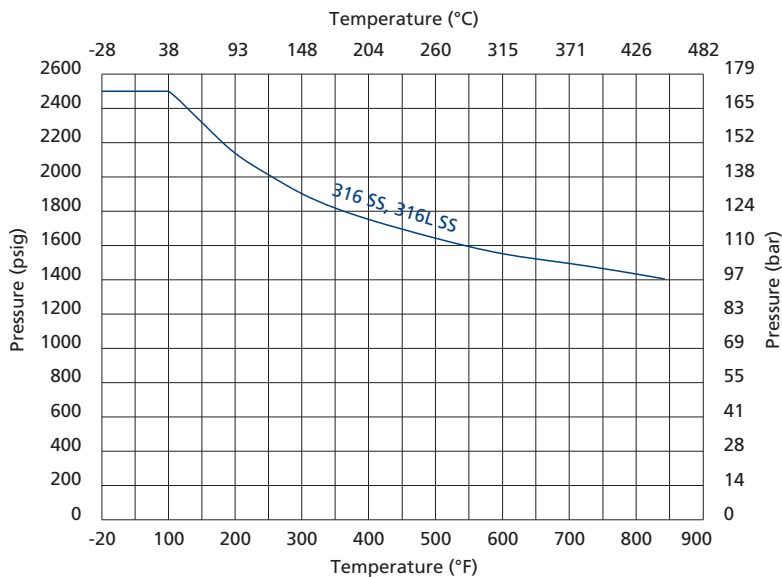

200°F (93°C) max. with PCTFE stem tip (soft tip).

Flow Coefficient vs. Turns Open

Regulating Stem

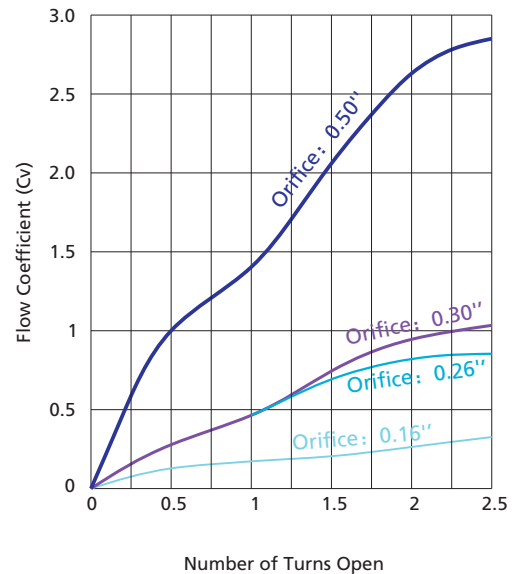

Standard Materials of Construction

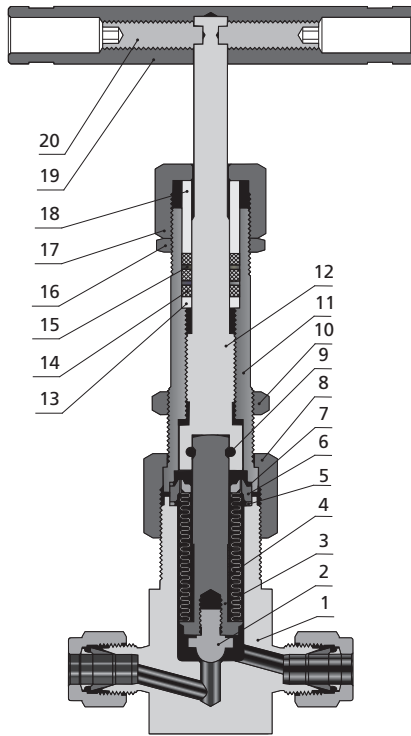

Tip Types

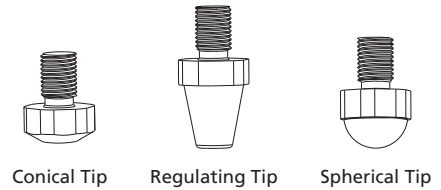

Component		Valve Body Material Grade/ASTM Specification	
		316 SS	
1	Body	316 SS/A182 or A479	
2	Stem Tip	Regulating	316 SS/A479 or Stellite
		Conical	PCTFE/D1430 or 316 SS/A479 or Stellite
		Spherical	Stellite
3	Stem	316 SS/A479	
4	Bellows	316L SS/A240	
5	Gasket	Silver-plated 316L SS/A269	
6	Weld Ring	316 SS/A479	
7	Gasket	Silver-plated 316L SS/A269	
8	Bonnet Nut	316 SS/A479	
9	Pin	Stainless steel	
10	Panel Mount Nut	Stainless steel	
11	Bonnet	316 SS/A479	
12	Actuator	440C SS/A479	
13	Packing washer	316 SS/A479	
14	Packing	Graphite	
15	Packing washer	316 SS/A479	
16	Luck Nut	Stainless steel	
17	Packing Nut	316 SS/A479	
18	Gland	316 SS/A479	
19	Handle	6061/B210 /Stainless steel	
20	Set Screws	Galvanized carbon steel	

Contact FITOK Group or our authorized distributors for valves of other materials.

Dimensions

Orifice: ≤ 0.30 "

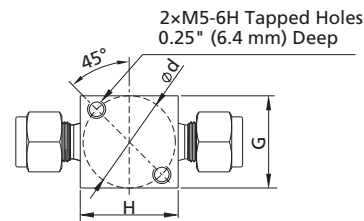
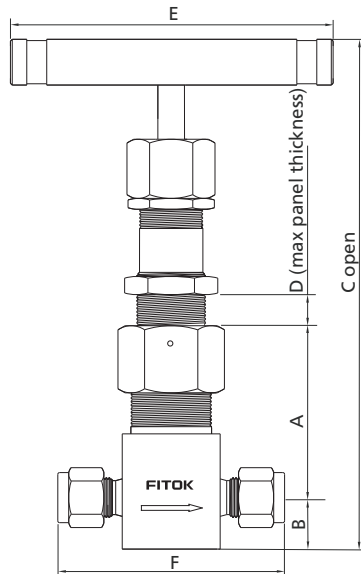

Basic Ordering Number	End Connections		Orifice in. (mm)	Cv	Dimensions, in. (mm)								
	Inlet Size	Outlet Size			A	B	C	D	E	F	G	H	Ød
SU□□-FL4-2-	1/4" FITOK	1/4" FITOK	0.16 (4.10)	0.36	1.86 (47.3)	0.54 (14.2)	6.34 (161.0)	0.38 (9.7)	3.50 (88.9)	2.46 (62.5)	1.00 (25.4)	1.07 (27.2)	1.00 (25.4)
SU□□-FL6-3-	3/8" FITOK	3/8" FITOK	0.26 (6.60)	0.85	1.94 (49.3)	0.50 (12.7)	6.36 (161.5)	0.38 (9.7)	3.50 (88.9)	3.09 (78.5)	1.13 (28.7)	1.57 (40.0)	1.13 (28.7)
SU□□-FL8-5-	1/2" FITOK	1/2" FITOK	0.30 (7.60)	1.20	1.98 (50.3)	0.50 (12.7)	6.40 (162.5)	0.38 (9.7)	3.50 (88.9)	3.30 (83.8)	1.13 (28.7)	1.57 (40.0)	1.13 (28.7)
SU□□-ML6-2-	6 mm FITOK	6 mm FITOK	0.16 (4.10)	0.36	1.86 (47.3)	0.56 (14.2)	6.34 (161.0)	0.38 (9.7)	3.50 (88.9)	2.46 (62.5)	1.00 (25.4)	1.05 (26.6)	1.00 (25.4)
SU□□-ML10-4-	10 mm FITOK	10 mm FITOK	0.28 (7.10)	1.00	1.97 (50.1)	0.50 (12.7)	6.39 (162.3)	0.38 (9.7)	3.50 (88.9)	3.11 (79.0)	1.13 (28.7)	1.57 (40.0)	1.13 (28.7)
SU□□-ML12-4-	12 mm FITOK	12 mm FITOK	0.28 (7.10)	1.00	1.97 (50.1)	0.50 (12.7)	6.39 (162.3)	0.38 (9.7)	3.50 (88.9)	3.30 (83.8)	1.13 (28.7)	1.57 (40.0)	1.13 (28.7)
SU□□-TS4-2-	1/4" TS	1/4" TS	0.16 (4.10)	0.36	1.86 (47.3)	0.56 (14.2)	6.34 (161.0)	0.38 (9.7)	3.50 (88.9)	1.68 (42.7)	1.00 (25.4)	1.00 (25.4)	1.00 (25.4)
SU□□-TS6-4-	3/8" TS	3/8" TS	0.28 (7.10)	1.00	1.97 (50.1)	0.50 (12.7)	6.39 (162.3)	0.38 (9.7)	3.50 (88.9)	2.27 (57.7)	1.13 (28.7)	1.52 (38.6)	1.13 (28.7)
SU□□-TS8-5-	1/2" TS	1/2" TS	0.30 (7.60)	1.20	1.98 (50.3)	0.50 (12.7)	6.40 (162.5)	0.38 (9.7)	3.50 (88.9)	2.27 (57.7)	1.13 (28.7)	1.52 (38.6)	1.13 (28.7)
SU□□-FFR4-2-	1/4" Female FR	1/4" Female FR	0.16 (4.10)	0.36	1.86 (47.3)	0.56 (14.2)	6.34 (161.0)	0.38 (9.7)	3.50 (88.9)	2.76 (70.1)	1.00 (25.4)	1.00 (25.4)	1.00 (25.4)
SU□□-FFR8-5-	1/2" Female FR	1/2" Female FR	0.30 (7.60)	1.20	1.98 (50.3)	0.50 (12.7)	6.40 (162.5)	0.38 (9.7)	3.50 (88.9)	3.12 (79.2)	1.13 (28.7)	1.52 (38.6)	1.13 (28.7)
SU□□-FR4-2-	1/4" Male FR	1/4" Male FR	0.16 (4.10)	0.36	1.86 (47.3)	0.56 (14.2)	6.34 (161.0)	0.38 (9.7)	3.50 (88.9)	2.24 (56.9)	1.00 (25.4)	1.00 (25.4)	1.00 (25.4)
SU□□-FR8-5-	1/2" Male FR	1/2" Male FR	0.30 (7.60)	1.20	1.98 (50.3)	0.50 (12.7)	6.40 (162.5)	0.38 (9.7)	3.50 (88.9)	3.00 (76.2)	1.13 (28.7)	1.52 (38.6)	1.13 (28.7)

1. FITOK means FITOK double ferrule tube fittings, FR means metal gasket seal fittings. TS means fractional tube socket weld.

TB means tube butt weld.

2. Dimensions are shown with FITOK nuts finger-tightened. All dimensions are for reference only and are subject to change. For dimensions not shown above, please contact FITOK Group or our authorized distributors..

3. The sizes and types listed are standard. Other sizes and types are available upon request. For special sizes and types, refer to ordering information.

Dimensions

Orifice: 0.50"

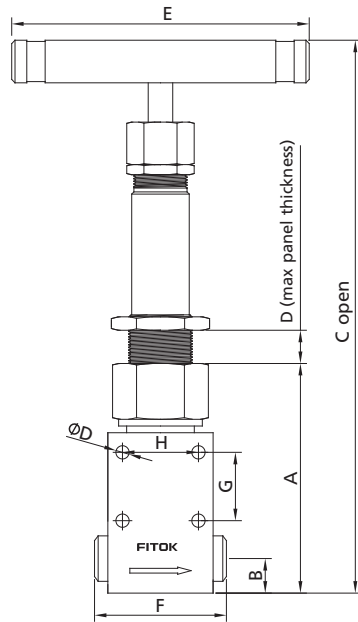

Orifice: 0.61"

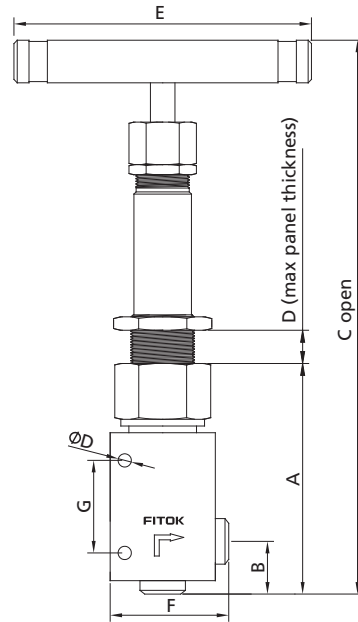

Bellows-sealed
Valves

Basic Ordering Number	End Connections		Orifice in. (mm)	CV	Dimensions, in. (mm)								
	Inlet Size	Outlet Size			A	B	C	D	E	F	G	H	Ød
SU□□-TS12-8-	3/4" TS	3/4" TS	0.50 (12.7)	3.10	5.45 (138.5)	1.00 (25.4)	11.60 (295)	0.59 (14.9)	5.00 (127)	2.44 (62.0)	1.25 (31.8)	1.46 (37.0)	0.27 (6.9)
SU□□-PB12-8-	3/4" PB	3/4" PB	0.50 (12.7)	3.10	5.45 (138.5)	1.00 (25.4)	11.60 (295)	0.59 (14.9)	5.00 (127)	2.44 (62.0)	1.25 (31.8)	1.46 (37.0)	0.27 (6.9)
SU□□-TS12-8A-	3/4" TS	3/4" TS	0.61 (15.5)	5.30	5.45 (138.5)	1.44 (36.6)	11.60 (295)	0.59 (14.9)	5.00 (127)	2.49 (63.2)	1.60 (40.6)	—	0.27 (6.9)
Su□□-PB12-8A-	3/4" PB	3/4" PB	0.61 (15.5)	5.30	5.45 (138.5)	1.44 (36.6)	11.60 (295)	0.59 (14.9)	5.00 (127)	2.49 (63.2)	1.60 (40.6)	—	0.27 (6.9)
SU□□-TB16-8A-	1" TB	1" TB	0.61 (15.5)	5.30	5.45 (138.5)	1.44 (36.6)	11.60 (295)	0.59 (14.9)	5.00 (127)	2.49 (63.2)	1.60 (40.6)	—	0.27 (6.9)

Pneumatic Actuators



Features

- ⦿ Low actuation pressure
- ⦿ Opens and closes quickly and reliably
- ⦿ Aluminum and stainless steel components

Actuation Modes

- ⦿ Normally closed—air opens, spring closes
- ⦿ Normally open—air closes, spring opens

Technical Data

Orifice	Working Temperature °F (°C)	Pressure Rating psig (bar)
0.30"	-20~200 (-28~93)	80~94 (5.5~6.5)
0.50"		87~116 (6~8)

For valve ratings, please refer to Pressure VS. Temperature on page B-131.

Materials of Construction

Component	Material
Housing	Anodized Aluminium
Stem Tip	Stellite
Bracket	Stainless Steel

For valve components, refer to "Standard Materials of Construction" on page B-132.

Dimensions

Dimensions are for reference only and subject to change

Normally closed, orifice ≤ 0.30 "

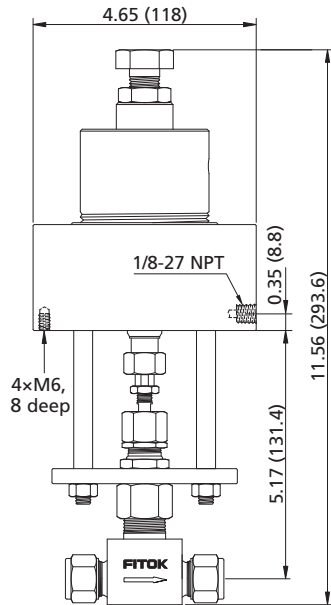

Normally open, orifice ≤ 0.30 "

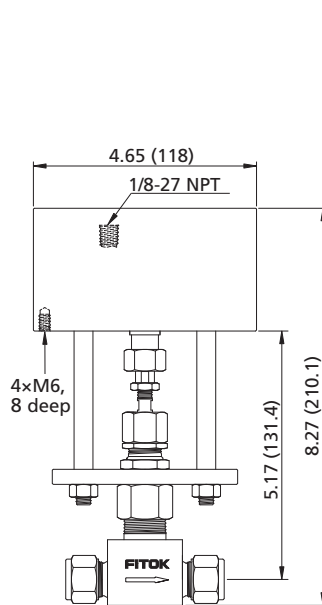

Normally closed, orifice 0.50"

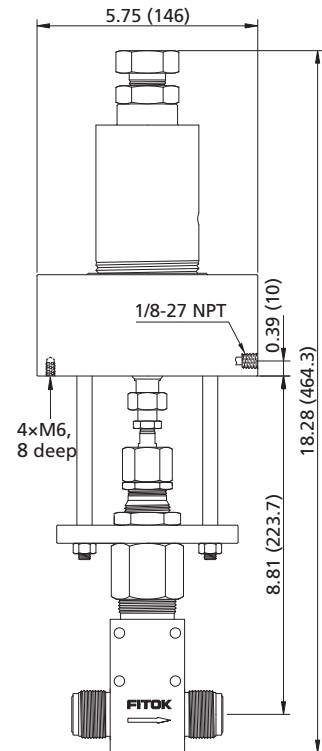

Ordering Information

To order valves with pneumatic actuators, add -LC or -LO to the valve ordering number. LC designates normally closed models; LO designates normally open models.

SU□□-□□-2/3/4/5-LC/LO

SU□□-□□-8-LC

Ordering Number Description

SUSS – FL8 – ML10 – 5 – WR – B – BW – SF2

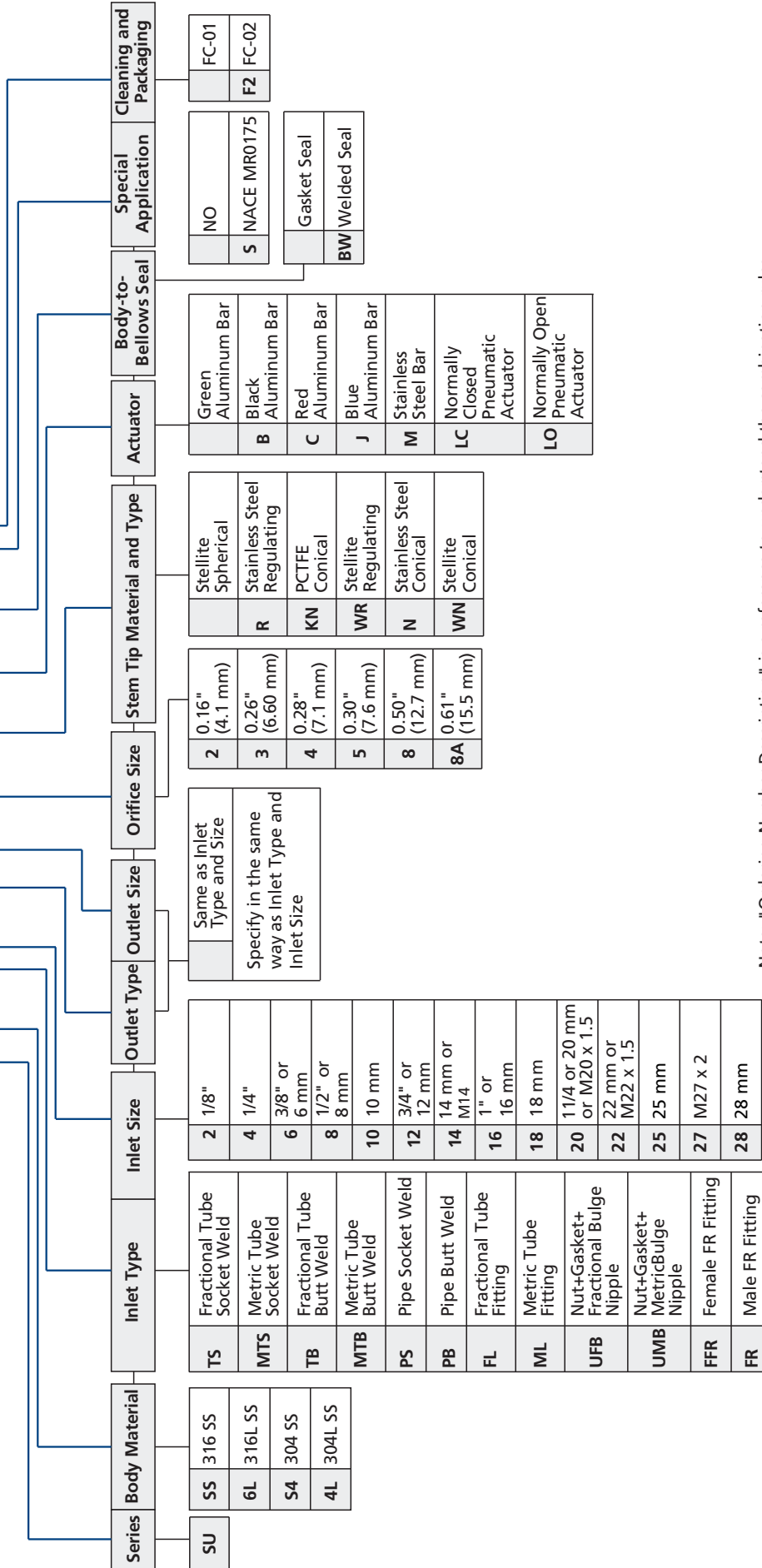

Note: "Ordering Number Description" is a reference to understand the combination rules of FITOK product part number. Not all combinations are available.

1. **Cleaning and Packaging:**
 FC-01: Standard cleaning and packaging for general industrial procedures.
 FC-02: Special cleaning and packaging for wetted system components to ensure compliance with product cleanliness requirement of ASTM G93 Level C.

info@fitokgroup.com
www.fitokgroup.com

FK-IC-GG-0%EN-#! !)"!

Proportional Relief Valves

RV, RL and RM Series

Check Valves
Relief Valves



Proportional Relief Valves

RV, RL and RM Series

Introduction

FITOK relief valves OPEN when system pressure reaches the set pressure and CLOSE when system pressure falls below the set pressure.



Features

- ⦿ Set pressure:
 - RV series: 7 color-coded springs available for a wide range of set pressure, 50 to 6000 psig @ 70°F (3.4 to 414 bar @ 20°C)
 - RL series: 10 to 225 psig @ 70°F (0.68 to 15.5 bar @ 20°C)
 - RM series: 3 color-coded springs available for a wide range of set pressure, 50 to 1500 psig @ 70°F (3.4 to 103 bar @ 20°C)
- ⦿ Maximum outlet pressure:
 - RV series: 1500 psig (103 bar)
 - RL series: 225 psig (15.5 bar)
 - RM series: 1500 psig (103 bar)
- ⦿ Orifice size:
 - RV series: 0.14" (3.6 mm)
 - RL series: 0.19" (4.8 mm) and 0.25" (6.4 mm)
 - RM series: 0.25" (6.4 mm)
- ⦿ Back pressure
 - Back pressure is the pressure of the outlet of valves. It increases the set pressure of proportional relief valves.
 - RV and RM series: Balanced stem design to eliminate the effect of system back pressure
 - RL series: Pre-set pressure = Desired pressure - 0.8 × Back pressure
- ⦿ Working temperature: -10°F to 300°F (-23°C to 148°C)
- ⦿ Variety of end connections
- ⦿ Liquid or gas service
- ⦿ Adjustable bonnet cap and adjustable set pressure
- ⦿ Lead seal through lock wire holes to lock proportional relief valve so as to secure a set pressure effectively
- ⦿ Variety of seal materials
- ⦿ Label identifies the set pressure range

Applications

Relief valves are proportional relief valves that open gradually as the pressure increases. Consequently, they do not have a capacity rating at a given pressure rise (accumulation), and they are not certified to ASME or any other codes.

- ⚠ **Some system applications require relief valves to meet specific safety codes. The system designer and user must determine when such codes apply and whether these relief valves conform to them.**
- ⚠ **FITOK proportional relief valves should never be used as ASME Boiler and Pressure Vessel Code safety relief devices.**
- ⚠ **FITOK proportional relief valves are not "Safety Accessories" as defined in the Pressure Equipment Directive 2014/68/EU.**

Temperature Range of Sealing Materials

O-ring Material	Temperature Ranges °F (°C)
Fluorocarbon Rubber	25 to 250 (-4 to 121)
Buna-N Rubber	0 to 250 (-17 to 121)
Neoprene Rubber	-10 to 300 (-23 to 148)
EPDM	30 to 250 (-1 to 121)

Set Pressure and Resealing Pressure

Set pressure: The set pressure is the upstream pressure at which the first indication of flow occurs. The repeatability of set pressure of each valve after initial relief is $\pm 5\%$ at room temperature.

Resealing pressure: The resealing pressure is the upstream pressure at which there is no indication of flow. Resealing pressure is always lower than set pressure.

Note: For valves not acutated for a period of time, the initial relief pressure may be higher than the set pressure.

RV Series

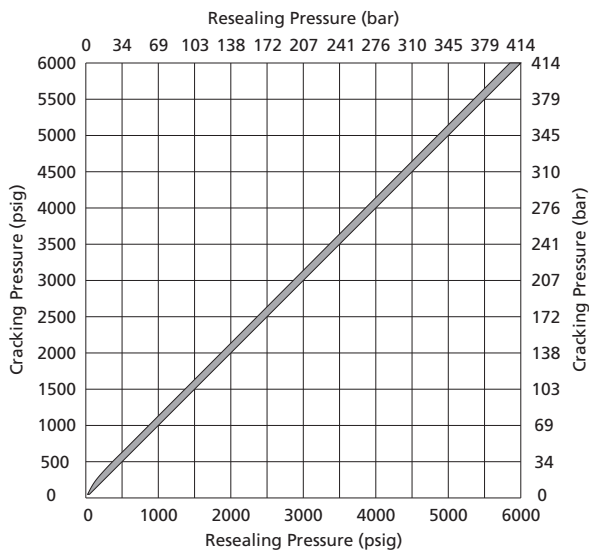

RM Series

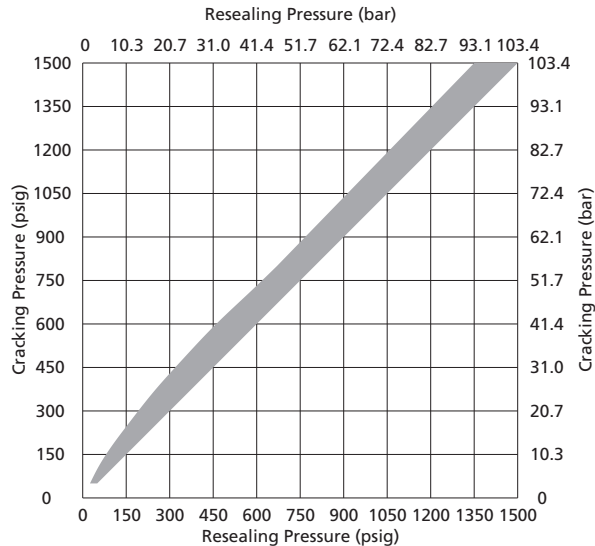

RL Series

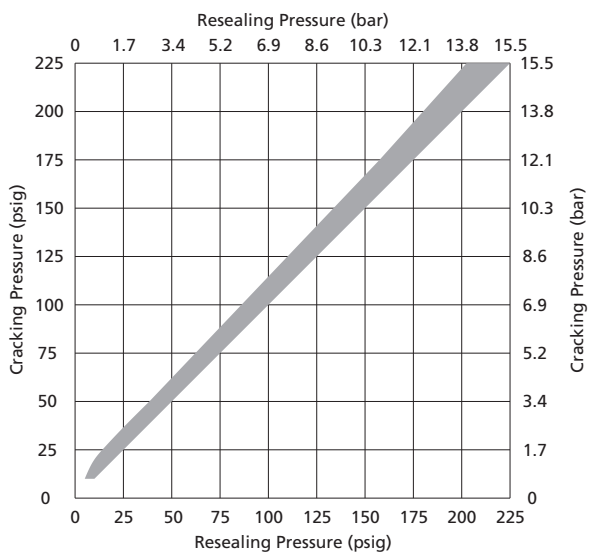

Flow Data at 70°F (20°C)

RV Series

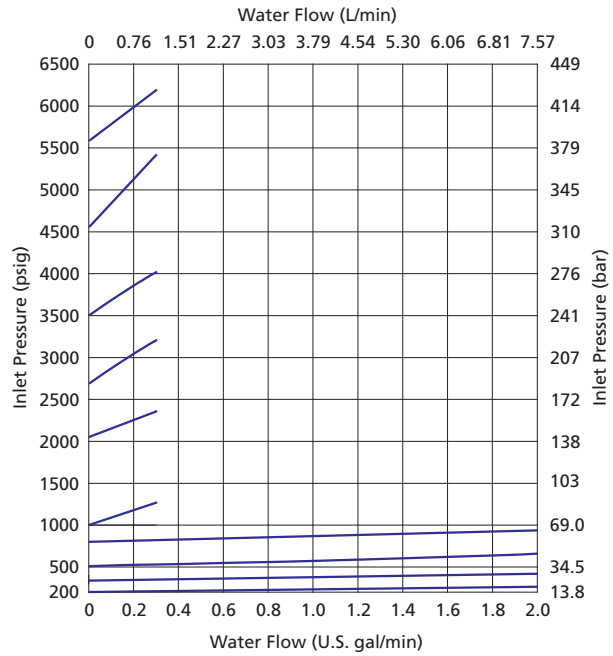
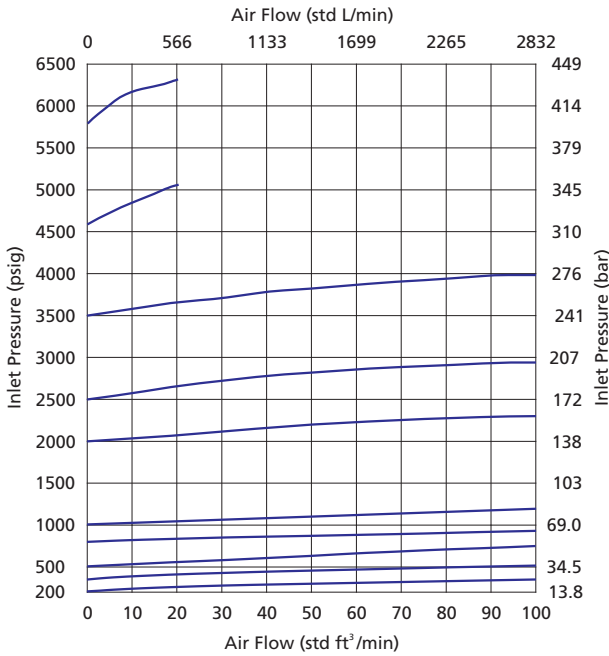

RL Series

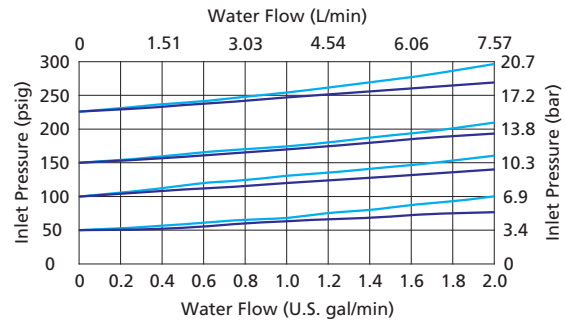
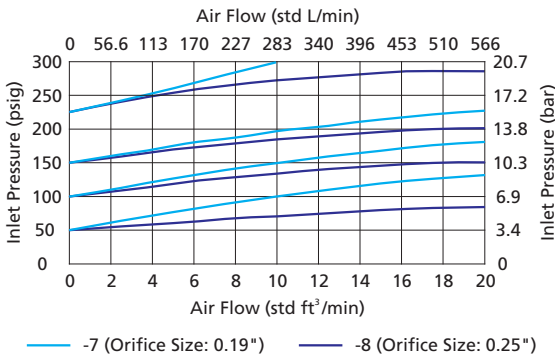

RM Series

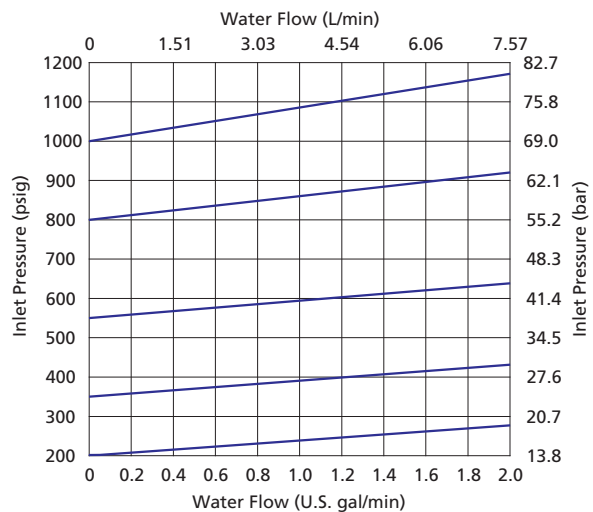
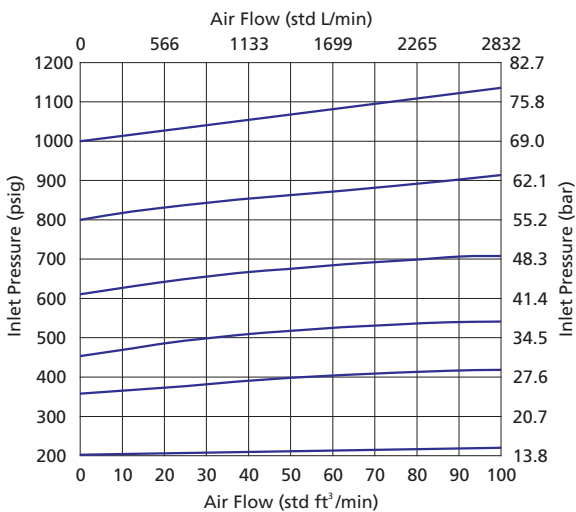

Standard Materials of Construction

RV Series

Component		Material Grade/ASTM Specification
1	<i>Body</i>	316 SS/A182
2	<i>Seat</i>	316 SS/A479
3	<i>O-ring</i>	Fluorocarbon FKM
4	<i>Gasket</i>	PEEK
5	<i>Seat Retainer</i>	316 SS/A479
6	<i>O-ring</i>	Fluorocarbon FKM
7	<i>Stem</i>	316 SS/A479
8	<i>O-ring</i>	Fluorocarbon FKM
9	<i>Bonnet</i>	316 SS/A479
10	<i>Spring Support</i>	316 SS/A479
11	<i>Spring</i>	S17700 SS/AMS 5678
12	<i>Lock Nut</i>	17-4PH powdered metal
13	<i>Label</i>	Polyester
14	<i>Bonnet Cap</i>	316 SS/A479

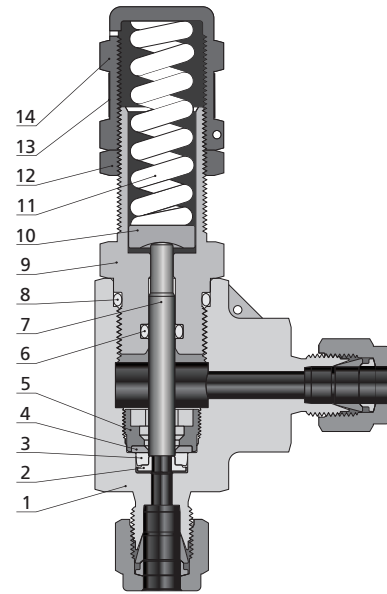

Note: Wetted components are listed in italics.

1. Lubricant: Silicone-based

2. Contact FITOK Group or our authorized distributors for other materials

RL Series

Component		Material Grade/ASTM Specification
1	<i>Body</i>	316 SS/A182
2	<i>Gasket</i>	316 SS/A479
3	<i>Seat</i>	316 SS/A479
4	<i>Bonded disc</i>	316 SS/A479+Fluorocarbon FKM
5	<i>Stem</i>	316 SS/A479
6	<i>Retainer</i>	316 SS/A479
6a	<i>Ring</i>	316 SS/A479
7	<i>Quad Seal</i>	Fluorocarbon FKM
8	<i>O-ring</i>	Fluorocarbon FKM
9	<i>Bonnet</i>	316 SS/A479
10	<i>Spring Support</i>	316 SS/A479
11	<i>Spring</i>	S17700 SS/AMS 5678
12	<i>Lock Nut</i>	17-4PH powdered metal
13	<i>Sleeve</i>	304SS/A240
14	<i>Label</i>	Polyester
15	<i>Bonnet Cap</i>	316 SS/A479

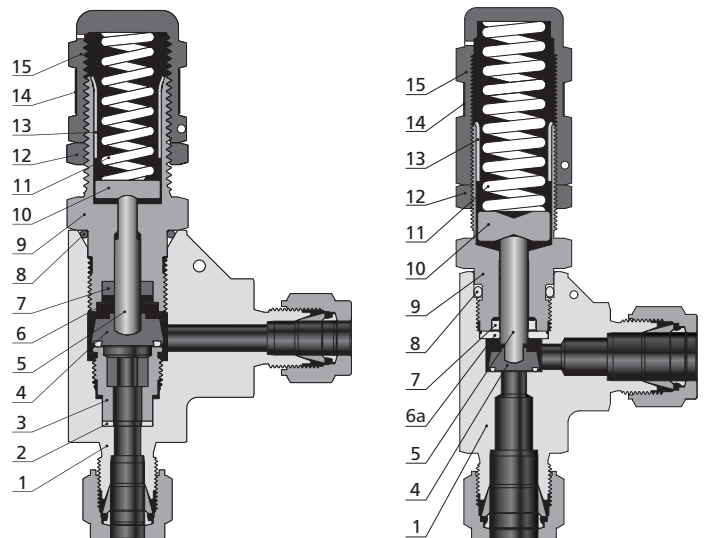

Orifice 7
0.19 in. (4.8 mm)

Orifice 8
0.25 in. (6.4 mm)

Note: Wetted components are listed in italics.

1. Lubricant: Silicone-based

2. Contact FITOK Group or our authorized distributors for other materials

RM Series

Component		Material Grade/ASTM Specification
1	Body	316 SS/A182
2	Stem	316 SS/A479+Fluorocarbon FKM
3	Retainer	316 SS/A479
4	Seal	Fluorocarbon FKM
5	Bonnet	316 SS/A479
6	O-ring	Fluorocarbon FKM
7	Spring Support	316 SS/A479
8	Spring	S17700 SS/AMS 5678
9	Lock Nut	17-4PH powdered metal
10	Label	Polyester
11	Bonnet Cap	316 SS/A479

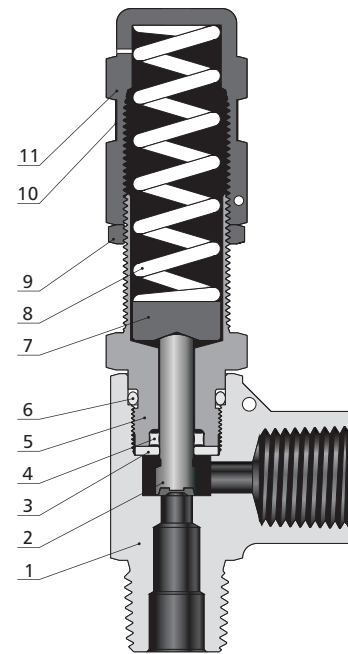

Note: Wetted components are listed in italics.

1. Lubricant: Silicone-based

2. Contact FITOK Group or our authorized distributors for other materials

Manual Override Handles

Lift the aluminum handle with hand to open the proportional relief valve without changing the set pressure. For use with following valves :

- RV Series — set pressure range 50~1500 psig
- RL Series — set pressure range 10~225 psig
- RM Series— set pressure range 50~300 psig

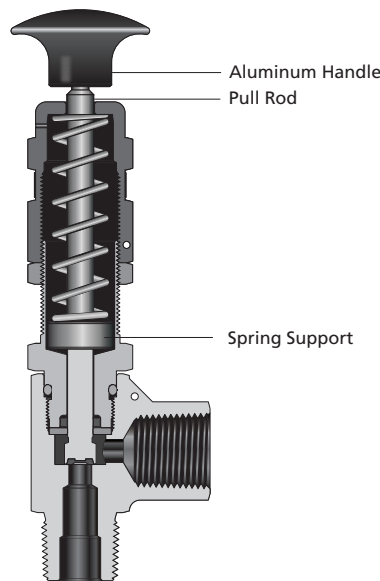

Dimensions

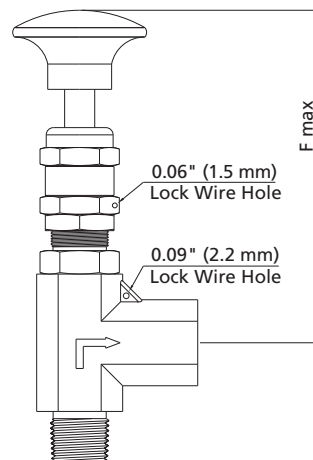
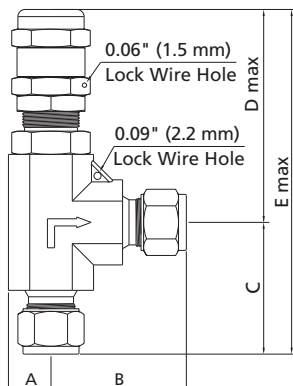

Check Valves
Relief Valves

RV Series

Basic Ordering Number	Connection Type and Size		Orifice in. (mm)	Dimensions, in. (mm)					
	Inlet	Outlet		A	B	C	Dmax	Emax	Fmax
RV□□-FL4-6-□	1/4" FITOK	1/4" FITOK	0.14 (3.6)	0.46 (11.9)	1.60 (40.6)	1.44 (36.6)	2.70 (68.6)	4.14 (105.2)	4.09 (103.9)
RV□□-FL6-6-□	3/8" FITOK	3/8" FITOK							
RV□□-FL8-6-□	1/2" FITOK	1/2" FITOK							
RV□□-ML6-6-□	6 mm FITOK	6 mm FITOK		0.46 (11.9)	1.60 (40.6)	1.44 (36.6)	2.70 (68.6)	4.14 (105.2)	4.09 (104.9)
RV□□-ML8-6-□	8 mm FITOK	8 mm FITOK							
RV□□-ML12-6-□	12 mm FITOK	12 mm FITOK							
RV□□-FNS4-6-□	1/4 Female NPT	1/4 Female NPT		0.46 (11.9)	1.17 (29.7)	1.38 (34.9)	2.70 (68.6)	4.08 (103.5)	4.28 (108.7)
RV□□-NS4-6-□	1/4 Male NPT	1/4 Male NPT							
RV□□-FRT4-6-□	1/4 Female BSPT	1/4 Female BSPT							

RL Series

Basic Ordering Number	Connection Type and Size		Orifice in. (mm)	Dimensions, in. (mm)					
	Inlet Size	Outlet Size		A	B	C	D	E	F
RL□□-FL4-7	1/4" FITOK	1/4" FITOK	0.19 (4.8)	0.46 (11.9)	1.60 (40.6)	1.44 (36.6)		4.14 (105.0)	4.09 (104.0)
RL□□-ML6-7	6 mm FITOK	6 mm FITOK							
RL□□-NS4-7	1/4 Male NPT	1/4 Male NPT							
RL□□-RT4-7	1/4 Male BSPT	1/4 Male BSPT			1.17 (29.7)	1.38 (34.9)		4.08 (103.5)	
RL□□-FNS4-7	1/4 Female NPT	1/4 Female NPT							
RL□□-FRT4-7	1/4 Female BSPT	1/4 Female BSPT							
RL□□-FL8-8	1/2" FITOK	1/2" FITOK	0.25 (6.4)	0.54 (13.7)	1.83 (46.5)	1.83 (46.5)	4.09 (104.0)	5.92 (150.0)	5.37 (136.0)
RL□□-ML12-8	12 mm FITOK	12 mm FITOK							
RL□□-NS8-8	1/2 Male NPT	1/2 Male NPT							
RL□□-RT8-8	1/2 Male BSPT	1/2 Male BSPT							
RL□□-FNS8-8	1/2 Female NPT	1/2 Female NPT							
RL□□-FRT8-8	1/2 Female BSPT	1/2 Female BSPT							

Check Valves
Relief Valves

RM Series

Basic Ordering Number	Connection Type and Size		Orifice in. (mm)	Dimensions, in. (mm)					
	Inlet Size	Outlet Size		A	B	C	D	E	F
RM□□-FL8-8-□	1/2" FITOK	1/2" FITOK	0.25 (6.4)	0.54 (13.7)	1.83 (46.5)	1.83 (46.5)	4.09 (104.0)	5.92 (150.0)	5.37 (136.0)
RM□□-ML12-8-□	12 mm FITOK	12 mm FITOK							
RM□□-NS8-8-□	1/2 Male NPT	1/2 Male NPT			1.44 (36.6)	1.44 (36.6)	5.52 (140.0)		
RM□□-RT8-8-□	1/2 Male BSPT	1/2 Male BSPT							
RM□□-FNS8-8-□	1/2 Female NPT	1/2 Female NPT							
RM□□-FRT8-8-□	1/2 Female BSPT	1/2 Female BSPT							

1. FITOK means FITOK double ferrule tube fittings.
2. Dimensions are shown with FITOK nuts finger-tightened. All dimensions are for reference only and are subject to change.
3. Sizes and types listed are standard. For other connection types and sizes, please contact FITOK Group or our authorized distributors.

Spring Kit Ordering Number Description

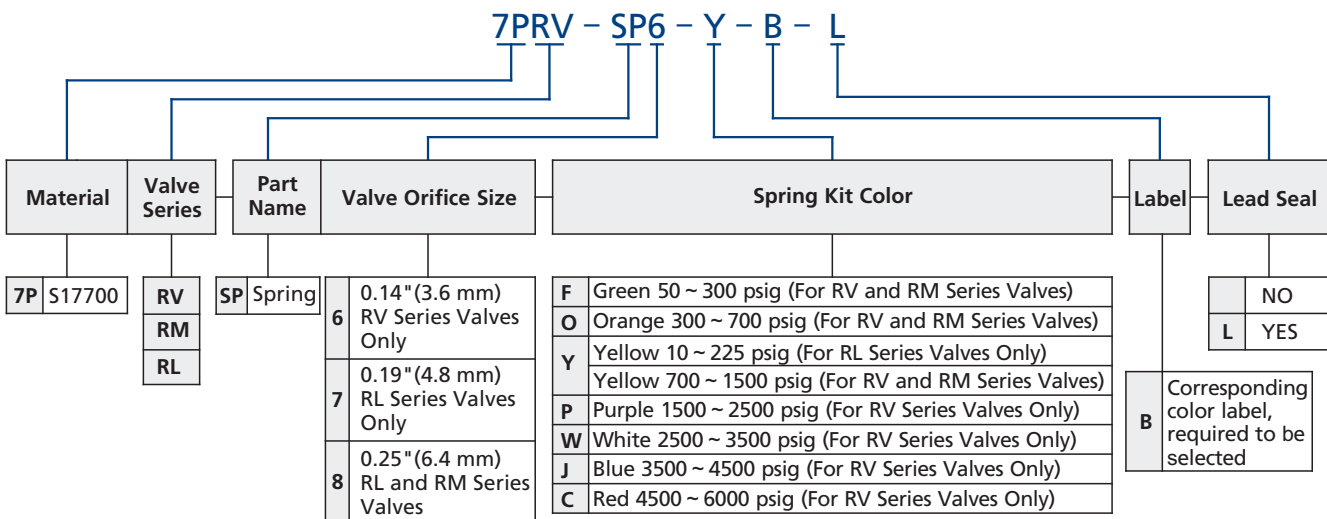

Note: "Ordering Number Description" is a reference to understand the combination rules of FITOK product part number. Not all combinations are available.

© Every spring kit includes a spring, a label and a lead seal (optional).

Check Valves
Relief Valves

Ordering Number Description

Valves

RVSS – FL6 – ML8 – 6Z – WM – TSF2

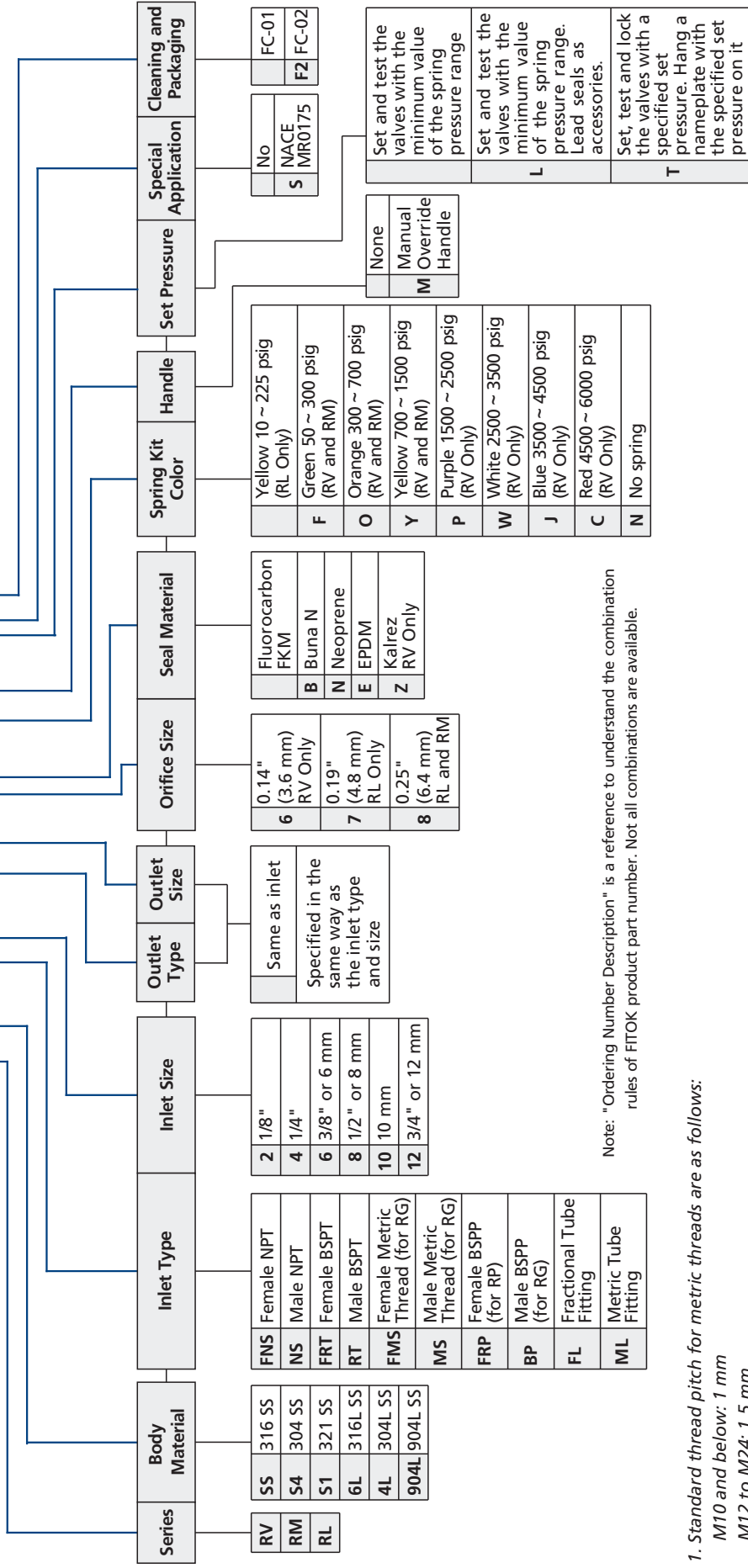

Note: "Ordering Number Description" is a reference to understand the combination rules of FITOK product part number. Not all combinations are available.

- Standard thread pitch for metric threads are as follows:
 M10 and below: 1 mm
 M12 to M24: 1.5 mm
 M27 and above: 2 mm
 Standard thread pitch should be ignored in the ordering number, others should be specified.
- Cleaning and Packaging:
 FC-01: Standard cleaning and packaging for general industrial procedures.
 FC-02: Special cleaning and packaging for wetted system components to ensure compliance with product cleaning requirement of ASTM G93 Level C.
 3. The color of the manual override handle is black. For other colors, please contact FITOK Group or our authorized distributors.
 4. For Proportional Relief Valves with specified set pressure on the nameplate, add the set pressure value (unit: psig) as a suffix to the ordering number.
 Example: RVSS-ML6-6-F-T-116PSIG.

Bleed Valves

RB Series



Bleed Valves
Purge Valves

Bleed Valves

RB Series

Introduction

Bleed valves can be used on instrument devices such as multi-valve manifolds or gauge valves to vent signal line pressure to atmosphere before removal of an instrument or to assist in calibration.

Features

- ⦿ Compact design for easy installation
- ⦿ Hardened stem and tip to extend cycle life
- ⦿ Working pressure up to: 10000 psig (690 bar)
- ⦿ Working temperature: -65°F to 850°F (-54°C to 454°C)
- ⦿ Variety of end connections
- ⦿ Leak-tight performance testing with Nitrogen or compressed air for every valve at the rated pressure (not higher than 6000 psig) to meet the requirement of no visible leak



Pressure vs. Temperature

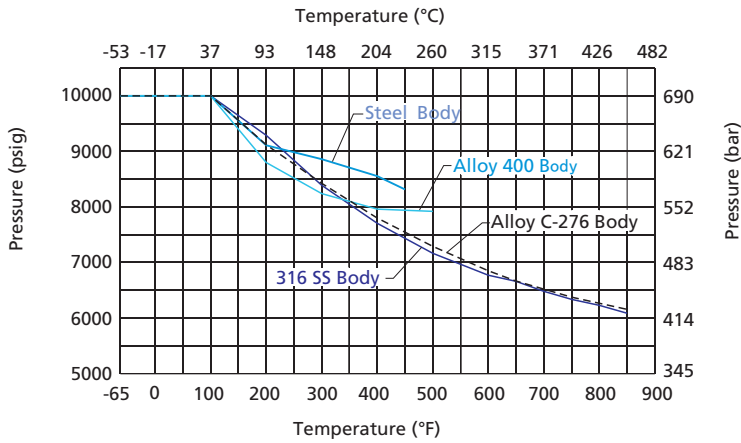

Note: Ratings based on all metal seals. Ratings limited to:

- -20°F (-28°C) min with steel.
- 450°F (232°C) max with SAE end connections using fluorocarbon FKM O-rings.
- 4500 psig (310 bar) max with SAE end connections.

Standard Materials of Construction

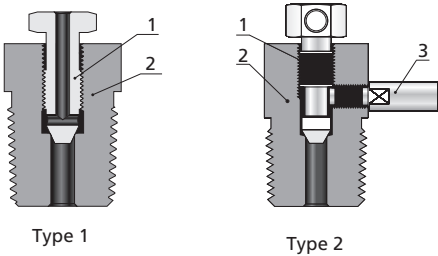

Component		Valve Body Material Grade/ASTM Specification			
		316 SS	Carbon Steel	Alloy 400	Alloy C-276
1	<i>Stem</i>	<i>Hardened 316 SS/A479</i>			
2	<i>Body</i>	316 SS/A479	1018/A108	<i>Alloy 400/B164</i>	<i>C-276/B574</i>
3	<i>Vent tube</i>	316 SS/A479			

Note: Wetted components are listed in italics.

1. Hydrocarbon carrier.
2. Contact FITOK Group or our authorized distributors for other materials.

Dimensions

Dimensions, in inches (millimeters), are for reference only and are subject to change.

Type 1

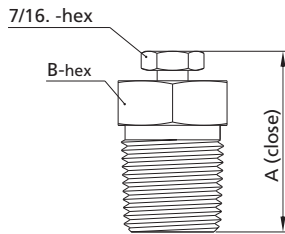

Type 2

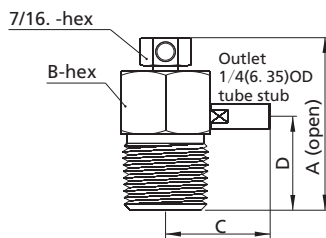

Type	Basic Ordering Number	Inlet Type and Size	Dimensions, in. (mm)			
			A	B	C	D
Type 1	RB□□-NS4	1/4 Male NPT	1.31 (33.4)	5/8 (15.9)	—	—
	RB□□-NS6	3/8 Male NPT	1.46 (37.1)	7/8 (22.2)		
	RB□□-NS8	1/2 Male NPT				
	RB□□-RT4	1/4 Male BSPT	1.31 (33.4)	5/8 (15.9)		
	RB□□-RT6	3/8 Male BSPT	1.46 (37.1)	7/8 (22.2)		
	RB□□-RT8	1/2 Male BSPT				
Type 2	RB□□-NS4-L	1/4 Male NPT	1.65 (41.8)	5/8 (15.9)	0.94 (24)	0.78 (19.7)
	RB□□-NS6-L	3/8 Male NPT	1.78 (45.1)	7/8 (22.2)	1.03 (26.2)	0.91 (23)
	RB□□-NS8-L	1/2 Male NPT			1.04 (26.3)	
	RB□□-RT4-L	1/4 Male BSPT	1.65 (41.8)	5/8 (15.9)	0.94 (24)	0.78 (19.7)
	RB□□-RT6-L	3/8 Male BSPT	1.78 (45.1)	7/8 (22.2)	1.03 (26.2)	0.91 (23)
	RB□□-RT8-L	1/2 Male BSPT			1.04 (26.3)	

Sizes and types listed are standard. Other sizes and types are available upon request.

Caution

When installing a bleed valve, position the vent tube to direct system fluid away from operating personnel. Always open bleed valves slowly. These valves contain no packing, so some fluid weepage will occur when the valves are opened. Operating personnel must protect themselves from exposure to system fluids.

Ordering Number Description

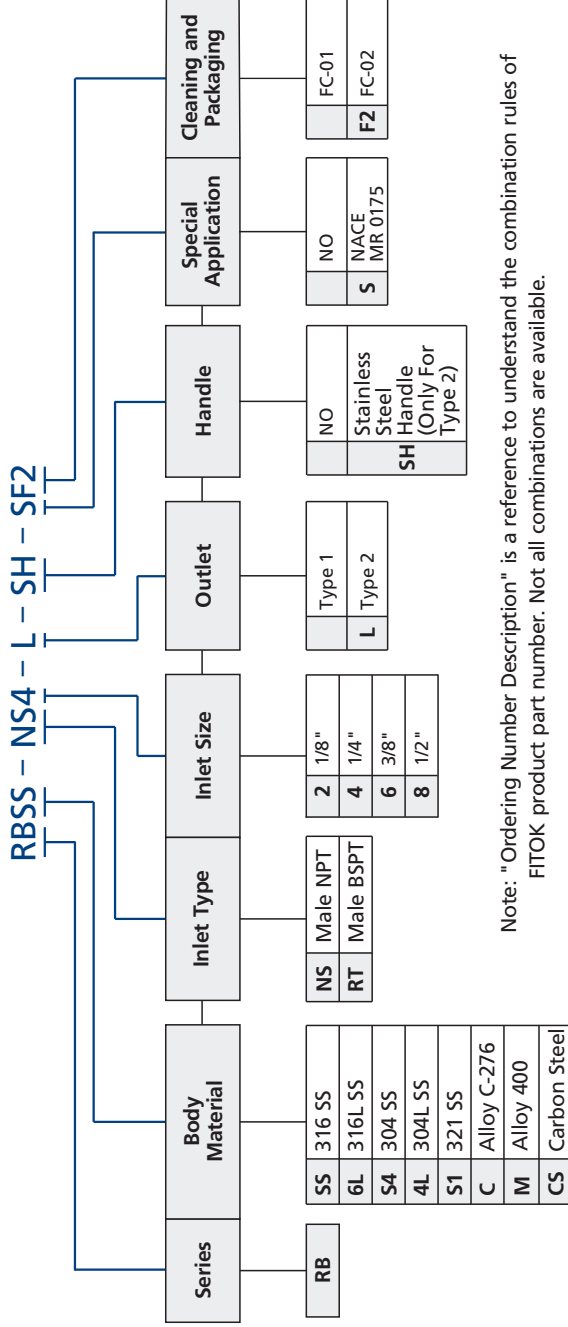

Note: "Ordering Number Description" is a reference to understand the combination rules of FITOK product part number. Not all combinations are available.

Cleaning and Packaging:

- FC-01: Standard cleaning and packaging for general industrial procedures.
- FC-02: Special cleaning and packaging for wetted system components to ensure compliance with product cleanliness requirement of ASTM G93 Level C.

Check Valves

CV, CH, CO, CA, COA, CL and CW Series



Check Valves
Relief Valves

Check Valves

CV, CH, CO, CA, COA, CL and CW Series



Features

CV Series

- ⦿ Resilient O-ring seat design for leak free sealing
- ⦿ Working pressure up to: 3000 psig (207 bar)
- ⦿ Working temperature: -10°F to 375°F (-23°C to 190°C)
- ⦿ Cracking pressure: 1/3 to 25 psig (0.02 to 1.7 bar)
- ⦿ Variety of end connections and materials available
- ⦿ Fixed cracking pressure, mountable in any directions

CH Series

- ⦿ Seat ring continuously cleaned by media, avoiding secondary pollution
- ⦿ Working pressure up to: 6000 psig (414 bar)
- ⦿ Working temperature: -10°F to 400°F (-23°C to 204°C)
- ⦿ Cracking pressure: 1/3 to 25 psig (0.02 to 1.7 bar)
- ⦿ Variety of end connections and materials available
- ⦿ Fixed cracking pressure, mountable in any directions
- ⦿ ECE R110 type approved valves for use in CNG/NGV application are available

CO Series

- ⦿ Compact design, one piece body
- ⦿ Working pressure up to: 3000 psig (207 bar)
- ⦿ Working temperature: -10°F to 375°F (-23°C to 190°C)
- ⦿ Cracking pressure: 1/3 to 25 psig (0.02 to 1.7 bar)
- ⦿ Variety of end connections and materials available
- ⦿ Fixed cracking pressure, mountable in any directions

CA Series

- ⦿ Working pressure up to: 3000 psig (207 bar)
- ⦿ Working temperature: -10°F to 375°F (-23°C to 190°C)
- ⦿ Cracking pressure: 3 to 600 psig (0.2 to 41.4 bar)
- ⦿ Variety of end connections and materials available
- ⦿ Various springs available
- ⦿ Adjustable cracking pressure, mountable in any directions

COA Series

- ⦿ Compact design, one-piece body
- ⦿ Working pressure up to: 3000 psig (207 bar)
- ⦿ Working temperature: -10°F to 375°F (-23°C to 190°C)
- ⦿ Cracking pressure: 3 to 600 psig (0.2 to 41.4 bar)
- ⦿ Variety of end connections and materials available
- ⦿ Various springs available
- ⦿ Adjustable cracking pressure, mountable in any directions

CL Series

- ⦿ Working pressure up to: 6000 psig (414 bar)
- ⦿ Working temperature: -65°F to 900°F (-53°C to 482°C)
- ⦿ Rugged, all-stainless steel construction
- ⦿ Union bonnet design, all-stainless steel structure, horizontal installation with bonnet nut on top
- ⦿ Reverse flow coefficient less than 0.1% of forward flow coefficient

CW Series

- ⦿ Working pressure up to: 3000 psig (207 bar)
- ⦿ Working temperature: -10°F to 400°F (-23°C to 204°C)
- ⦿ Cracking pressure: less than 2 psig (0.14 bar)
- ⦿ Variety of end connections and materials available
- ⦿ All-welded design for safety
- ⦿ Standard or fine polished wetted surfaces optional

1. Besides CL series, other check valves are all coated with lubricants like silicone base and molybdenum disulfide base.
2. Please contact FITOK Group or our authorized distributors for other materials.
3. PTFE-coated spring is an option for CV, CO, CA, and COA series check valves. For more details, please contact FITOK Group or our authorized distributors.
4. Every valve is tested with nitrogen for leak-tight performance at its maximum working pressure.

Cracking Pressure and Reseal Pressure

Cracking pressure - the upstream pressure at which the first indication of flow occurs.

Reseal pressure - the pressure at which there is no indication of flow.

Series	Nominal Cracking Pressure psig (bar)	Cracking Pressure Range psig (bar)	Reseal Pressure Range psig (bar)
CV	1/3 (0.02) 1 (0.06) 3 (0.21) 10 (0.68) 25 (1.7)	0 to 3 (0 to 0.21) 0 to 4 (0 to 0.28) 1 to 5 (0.06 to 0.34) 7 to 15 (0.49 to 1.1) 20 to 30 (1.4 to 2.1)	Up to 6 (0.42) downstream pressure Up to 6 (0.42) downstream pressure Up to 6 (0.42) downstream pressure 3 (0.21) or higher upstream pressure 17 (1.2) or higher upstream pressure
CH	1/3 (0.02) 1 (0.06) 3 (0.21) 10 (0.68) 25 (1.7)	0 to 3 (0 to 0.21) 0 to 4 (0 to 0.28) 1 to 5 (0.06 to 0.34) 7 to 15 (0.49 to 1.1) 20 to 30 (1.4 to 2.1)	Up to 6 (0.42) downstream pressure Up to 5 (0.35) downstream pressure Up to 2 (0.14) downstream pressure 3 (0.21) or higher upstream pressure 17 (1.2) or higher upstream pressure
CO	1/3 (0.02) 1 (0.06) 3 (0.21) 10 (0.68) 25 (1.7)	0 to 3 (0 to 0.21) 0 to 4 (0 to 0.28) 1 to 5 (0.06 to 0.34) 7 to 15 (0.49 to 1.1) 20 to 30 (1.4 to 2.1)	6 to 20 (0.42 to 1.4) downstream pressure 5 to 20 (0.35 to 1.4) downstream pressure 3 to 20 (0.21 to 1.4) downstream pressure 3 to 10 (0.21 to 0.68) downstream pressure 5 (0.35) or higher upstream pressure
CA	3 to 50 (0.21 to 3.4) 50 to 150 (3.4 to 10.3)	—————	Refer to the chart below
COA	150 to 350 (10.3 to 24.1) 350 to 600 (24.1 to 41.3)		
CW	1/3 (0.02)	0 to 2 (0 to 0.14)	Up to 2 (0.14) downstream pressure

Check Valves
Relief Valves

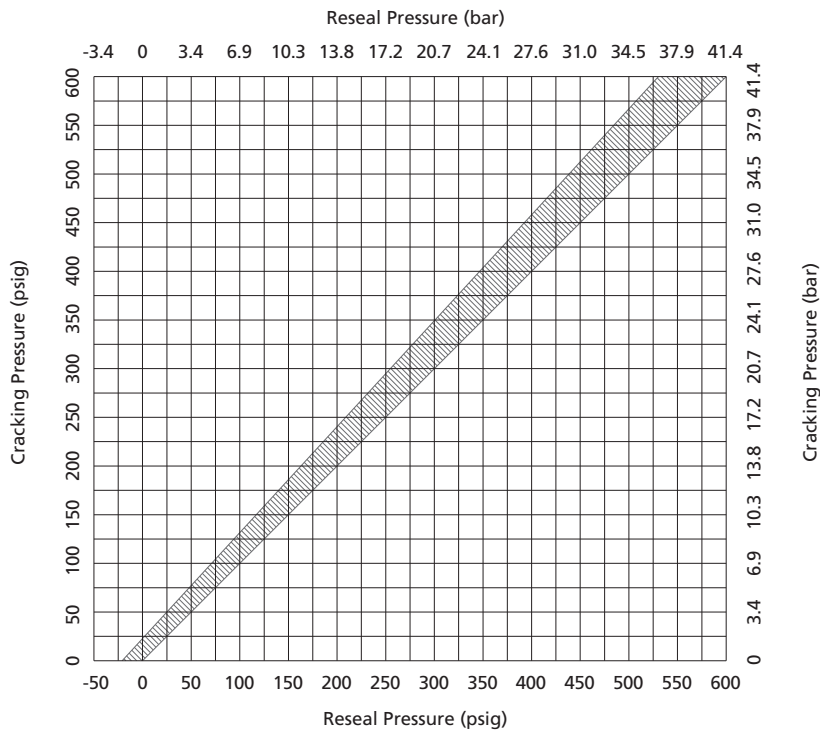

Pressure vs. Temperature

CV Series

FKM O-ring in 316 SS Body and Buna N in Brass Body

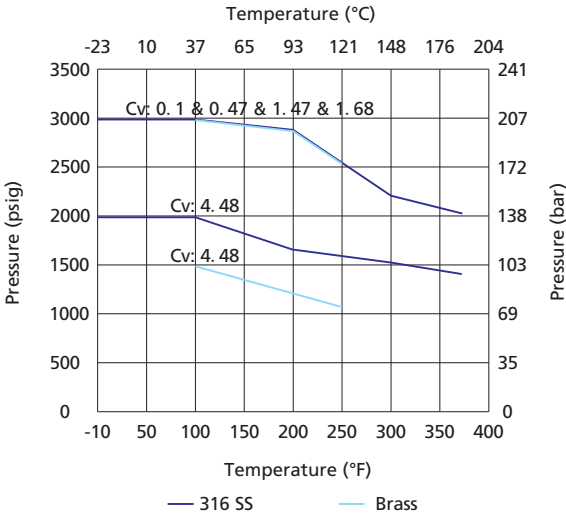

CO, CA and COA Series

FKM O-ring in 316 SS Body and Buna N in Brass Body

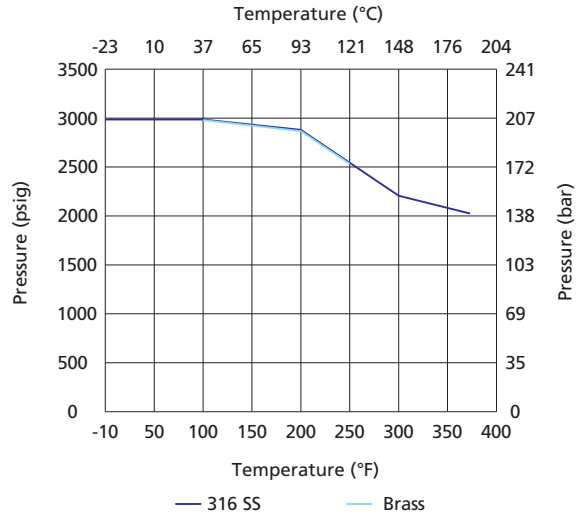

CL Series

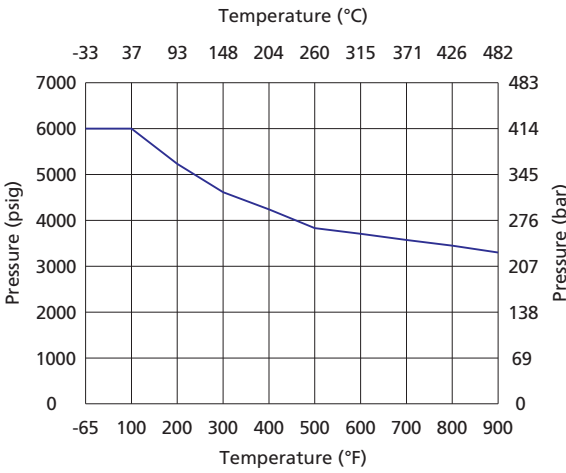

CH Series

FKM O-ring in 316 SS Body

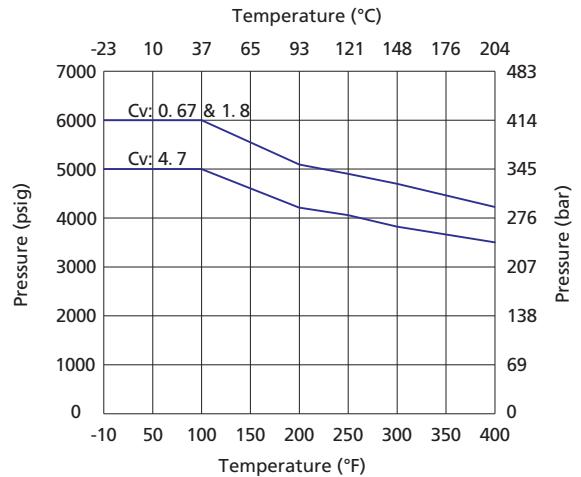

CW Series

FKM O-ring in 316 SS Body

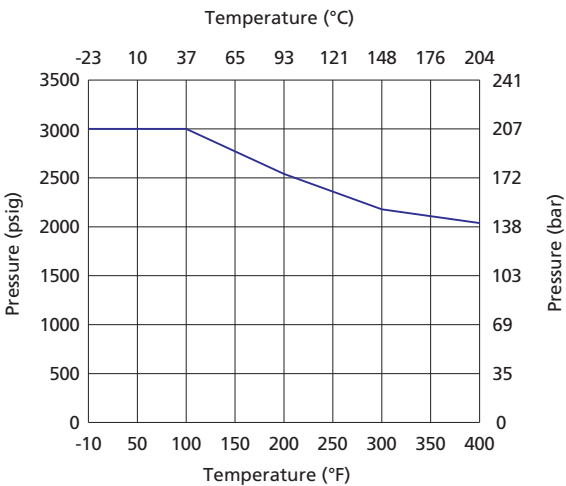

The temperature rating of CH Series check valve is restricted by the connection types. For details please refer to B-147.

Standard Materials of Construction

CV Series

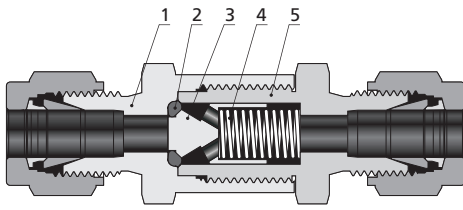

Component	Material Grade/ASTM Specification	
	316 SS	Brass
1 Inlet Body	316 SS/A479	Brass C36000/B16
2 O-ring	Fluorocarbon FKM	Buna N
3 Poppet	316 SS/A479	Brass C36000/B16
4 Spring	302 SS/A313	302 SS/A313
5 Outlet Body	316 SS/A479	Brass C36000/B16

CH Series

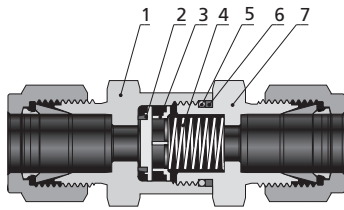

Component	Material Grade/ASTM Specification
1 Inlet Body	316 SS/A479
2 Poppet	Fluorocarbon-FKM-bonded 316 SS/A479
3 Poppet Stop	316 SS/A240
4 Spring	302 SS/A313
5 O-ring	Fluorocarbon FKM
6 Backup Ring	PTFE/D1710
7 Outlet Body	316 SS/A479

CO Series

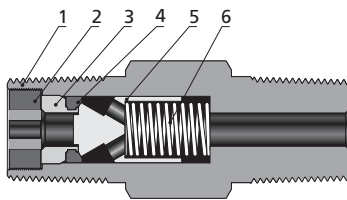

Component	Material Grade/ASTM Specification	
	316 SS	Brass
1 Body	316 SS/A479	Brass C36000/B16
2 Insert Locking Screw	316 SS/A276 or A479	Brass C36000/B16
3 Insert	316 SS/A479	Brass C36000/B16
4 O-ring	Fluorocarbon FKM	Buna N
5 Poppet	316 SS/A479	Brass C36000/B16
6 Spring	302 SS/A313	302 SS/A313

CA Series

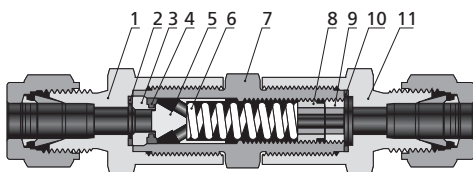

Component	Material Grade/ASTM Specification	
	316 SS	Brass
1 Inlet Body	316 SS/A479	Brass C36000/B16
2 Inlet Gasket	PTFE-coated 316 SS/A240	PTFE-coated 316 SS/A240
3 Insert	316 SS/A479	Brass C36000/B16
4 O-ring	Fluorocarbon FKM	Buna N
5 Poppet	316 SS/A479	Brass C36000/B16
6 Spring	302 SS/A313	302 SS/A313
7 Center Body	316 SS/A479	Brass C36000/B16
8 Adjusting Screw	316 SS/A276	316 SS/A276
9 Locking Screw	316 SS/A276	316 SS/A276
10 Outlet Gasket	PTFE-coated 316 SS/A276	PTFE-coated 316 SS/A276
11 Outlet Body	316 SS/A479	Brass C36000/B16

Check Valves
Relief Valves

B-144 Check Valves

COA Series

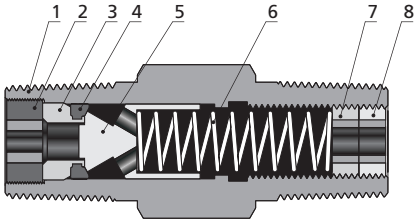

Component		Material Grade/ASTM Specification	
		316 SS	Brass
1	Body	316 SS/A479	Brass C36000/B16
2	Insert Locking Screw	316 SS/A479	Brass C36000/B16
3	Insert	316 SS/A479	Brass C36000/B16
4	O-ring	Fluorocarbon FKM	Buna N
5	Poppet	316 SS/A479	Brass C36000/B16
6	Spring	302 SS/A313	302 SS/A313
7	Adjusting Screw	316 SS/A276	316 SS/A276
8	Locking Screw	316 SS/A276	316 SS/A276

CL Series

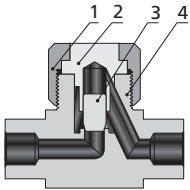

Component		Material Grade/ASTM Specification
1	Bonnet Nut	316 SS/A479
2	Bonnet	316 SS/A479
3	Poppet	S17400/A564
4	Body	316 SS/A479

CW Series

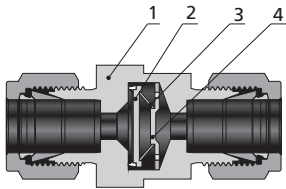

Component		Material Grade/ASTM Specification
1	Body	316L SS/A479
2	Poppet	Fluorocarbon FKM-bonded 316 SS/A479
3	Belleville Spring	Alloy X - 750/B637
4	Poppet Stop	316L SS/A240

Dimensions

CV Series

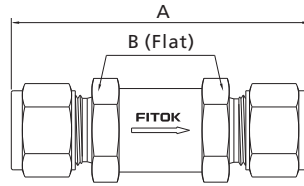

Basic Ordering Number	Connection Type and Size		Cv	Dimensions, in. (mm)	
	Inlet	Outlet		A	B
CV□□-FL2-	1/8" FITOK	1/8" FITOK	0.10	2.14 (54.3)	5/8 (15.9)
CV□□-FL4-	1/4" FITOK	1/4" FITOK	0.47	2.35 (59.7)	
CV□□-FL6-	3/8" FITOK	3/8" FITOK	1.47	3.17 (80.5)	7/8 (22.2)
CV□□-FL8-	1/2" FITOK	1/2" FITOK	1.68	3.42 (86.9)	
CV□□-FL12-	3/4" FITOK	3/4" FITOK	4.48	4.32 (110.0)	1 1/4 (31.8)
CV□□-FL16-	1" FITOK	1" FITOK		4.74 (120.0)	1 3/8 (34.9)
CV□□-ML6-	6 mm FITOK	6 mm FITOK	0.47	2.36 (59.9)	5/8 (15.9)
CV□□-ML10-	10 mm FITOK	10 mm FITOK	1.68	3.32 (84.3)	7/8 (22.2)
CV□□-ML12-	12 mm FITOK	12 mm FITOK		3.42 (86.9)	
CV□□-FNS2-	1/8 Female NPT	1/8 Female NPT	0.10	1.89 (48.0)	5/8 (15.9)
CV□□-FNS4-	1/4 Female NPT	1/4 Female NPT	0.47	2.15 (54.6)	3/4 (19.1)
CV□□-FNS6-	3/8 Female NPT	3/8 Female NPT	1.47	2.98 (75.7)	7/8 (22.2)
CV□□-FNS8-	1/2 Female NPT	1/2 Female NPT	1.68	3.58 (90.9)	1 1/16 (27.0)
CV□□-FNS12-	3/4 Female NPT	3/4 Female NPT	4.48	4.08 (104.0)	1 1/4 (31.8)
CV□□-FNS16-	1 Female NPT	1 Female NPT		4.84 (123.0)	1 5/8 (41.3)
CV□□-NS2-	1/8 Male NPT	1/8 Male NPT	0.10	1.71 (43.4)	5/8 (15.9)
CV□□-NS4-	1/4 Male NPT	1/4 Male NPT	0.47	2.09 (53.1)	
CV□□-NS6-	3/8 Male NPT	3/8 Male NPT	1.47	2.78 (70.6)	7/8 (22.2)
CV□□-NS8-	1/2 Male NPT	1/2 Male NPT	1.68	3.16 (80.3)	
CV□□-NS12-	3/4 Male NPT	3/4 Male NPT	4.48	4.08 (104.0)	1 1/4 (31.8)
CV□□-NS16-	1 Male NPT	1 Male NPT		4.52 (115.0)	1 5/8 (41.3)
CV□□-FR4-	1/4" Male FR	1/4" Male FR	0.47	2.21 (56.1)	5/8 (15.9)
CV□□-FR8-	1/2" Male FR	1/2" Male FR	1.68	3.56 (90.4)	15/16 (23.8)
CV□□-FR12-	3/4" Male FR	3/4" Male FR	4.48	4.64 (118.0)	1 5/8 (41.3)
CV□□-FR16-	1" Male FR	1" Male FR		4.76 (121.0)	

Ordering Number Description

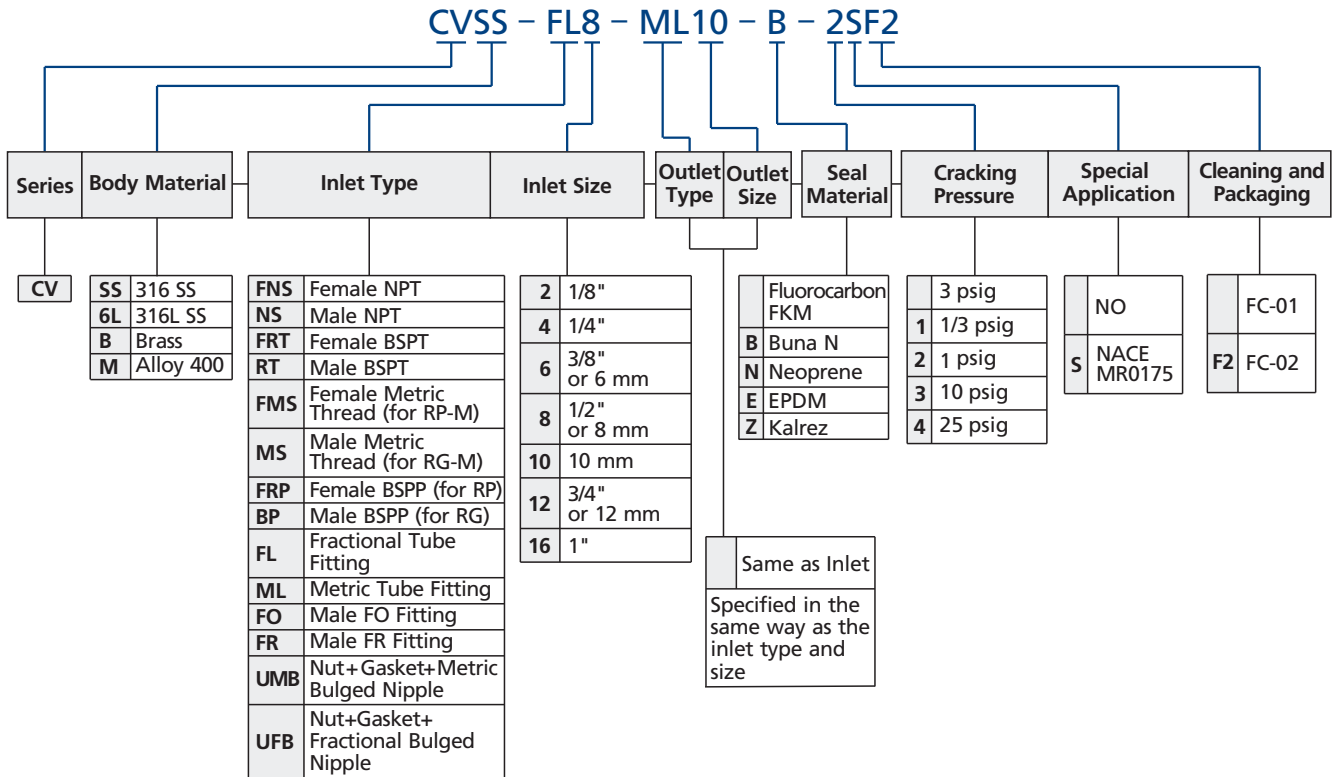

- Standard thread pitch for metric threads are as follows:
M10 and below: 1 mm
M12 to M24: 1.5 mm
M27 and above: 2 mm
Standard thread pitch should be omitted in the ordering number, others should be specified.
- For oxygen-enriched environment or hazardous media service, please contact FITOK Group or our authorized distributors.
- Cleaning and Packaging:
FC-01: Standard cleaning and packaging for general industrial procedures.
FC-02: Special cleaning and packaging for wetted system components to ensure compliance with product cleanliness requirement of ASTM G93 Level C.
- The materials, connection types and sizes listed in the "Ordering Number Description" are standard. For other materials and end connections, please contact FITOK Group or our authorized distributors.
- PTFE-coated gasket can be chosen to reduce the possibility of O-ring's moving in system caused by the pressure fluctuations, vibration or pulsating. For more details, please contact FITOK Group or our authorized distributors.
- Check valve is designed with unidirectional flow path, it can't be used as safety relief valve.
- If the check valve is not opened for a period of time, its initial cracking pressure may be higher than set cracking pressure.

CH Series

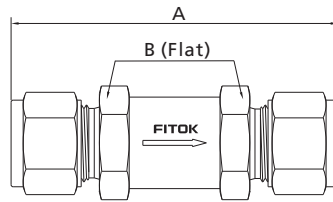

Basic Ordering Number	Connection Type and Size		Pressure Rating at 100° F (37° C) bar (psig)	Cv	Dimensions, in. (mm)	
	Inlet	Outlet			A	B
CH□□-FL2-	1/8" FITOK	1/8" FITOK	414 (6000)	0.67	2.27 (57.7)	11/16 (17.5)
CH□□-FL4-	1/4" FITOK	1/4" FITOK			2.43 (61.7)	
CH□□-FL6-	3/8" FITOK	3/8" FITOK		1.8	2.75 (69.9)	1 (25.4)
CH□□-FL8-	1/2" FITOK	1/2" FITOK	2.96 (75.2)			
CH□□-FL12-	3/4" FITOK	3/4" FITOK	344 (5000)	4.7	3.52 (89.4)	1 5/8 (41.3)
CH□□-FL16-	1" FITOK	1" FITOK	323 (4700)		3.88 (98.6)	
CH□□-ML6-	6 mm FITOK	6 mm FITOK	414 (6000)	0.67	2.43 (61.7)	11/16 (17.5)
CH□□-ML8-	8 mm FITOK	8 mm FITOK			2.70 (68.6)	
CH□□-ML10-	10 mm FITOK	10 mm FITOK		1.8	2.80 (71.1)	1 (25.4)
CH□□-ML12-	12 mm FITOK	12 mm FITOK			2.96 (75.2)	
CH□□-ML22-	22 mm FITOK	22 mm FITOK	337 (4900)	4.7	3.48 (88.4)	1 5/8 (41.3)
CH□□-ML25-	25 mm FITOK	25 mm FITOK	316 (4600)		3.88 (98.6)	
CH□□-FNS4-	1/4 Female NPT	1/4 Female NPT	414 (6000)	0.67	2.13 (54.1)	11/16 (17.5)
CH□□-FNS6-	3/8 Female NPT	3/8 Female NPT	365 (5300)	1.8	2.55 (64.8)	1(25.4)
CH□□-FNS8-	1/2 Female NPT	1/2 Female NPT	337 (4900)		3.03 (77.0)	1 1/16 (27.0)
CH□□-FNS12-	3/4 Female NPT	3/4 Female NPT	316 (4600)	4.7	3.23 (82.0)	1 5/8 (41.3)
CH□□-FNS16-	1 Female NPT	1 Female NPT	303 (4400)		3.83 (97.3)	
CH□□-NS2-	1/8 Male NPT	1/8 Male NPT	414 (6000)	0.67	1.79 (45.4)	11/16 (17.5)
CH□□-NS4-	1/4 Male NPT	1/4 Male NPT			2.17 (55.1)	
CH□□-NS6-	3/8 Male NPT	3/8 Male NPT		1.8	2.36 (59.9)	1 (25.4)
CH□□-NS8-	1/2 Male NPT	1/2 Male NPT	2.73 (69.3)			
CH□□-NS12-	3/4 Male NPT	3/4 Male NPT	344 (5000)	4.7	3.29 (83.6)	1 5/8 (41.3)
CH□□-NS16-	1 Male NPT	1 Male NPT			3.67 (93.2)	
CH□□-FRT4-	1/4 Female BSPT	1/4 Female BSPT	414 (6000)	0.67	2.28 (57.9)	11/16 (17.5)
CH□□-FRT8-	1/2 Female BSPT	1/2 Female BSPT	351 (5100)	1.8	3.29 (83.6)	1 1/16 (27.0)
CH□□-FRT12-	3/4 Female BSPT	3/4 Female BSPT	330 (4800)	4.7	3.55 (90.2)	1 5/8 (41.3)
CH□□-FRT16-	1 Female BSPT	1 Female BSPT	303 (4400)		3.83 (97.3)	
CH□□-RT4-	1/4 Male BSPT	1/4 Male BSPT	414 (6000)	0.67	2.17 (55.1)	11/16 (17.5)
CH□□-RT8-	1/2 Male BSPT	1/2 Male BSPT		1.8	2.73 (69.3)	1 (25.4)
CH□□-RT12-	3/4 Male BSPT	3/4 Male BSPT	344 (5000)	4.7	3.35 (85.1)	1 5/8 (41.3)
CH□□-RT16-	1 Male BSPT	1 Male BSPT			3.67 (93.2)	
CH□□-FR4-	1/4" Male FR	1/4" Male FR	414 (6000)	0.67	2.28 (57.9)	11/16 (17.5)
CH□□-FR8-	1/2" Male FR	1/2" Male FR	296 (4300)	1.8	2.73 (69.3)	1 (25.4)
CH□□-FR12-	3/4" Male FR	3/4" Male FR	254 (3700)	4.7	3.78 (96.0)	1 5/8 (41.3)
CH□□-FO4-	1/4" Male FO	1/4" Male FO	414 (6000)	0.67	1.98 (50.3)	11/16 (17.5)
CH□□-FO8-	1/2" Male FO	1/2" Male FO		1.8	2.35 (59.7)	1 (25.4)
CH□□-FO12-	3/4" Male FO	3/4" Male FO	344 (5000)	4.7	2.90 (73.7)	1 5/8 (41.3)
CH□□-FO16-	1" Male FO	1" Male FO				

Ordering Number Description

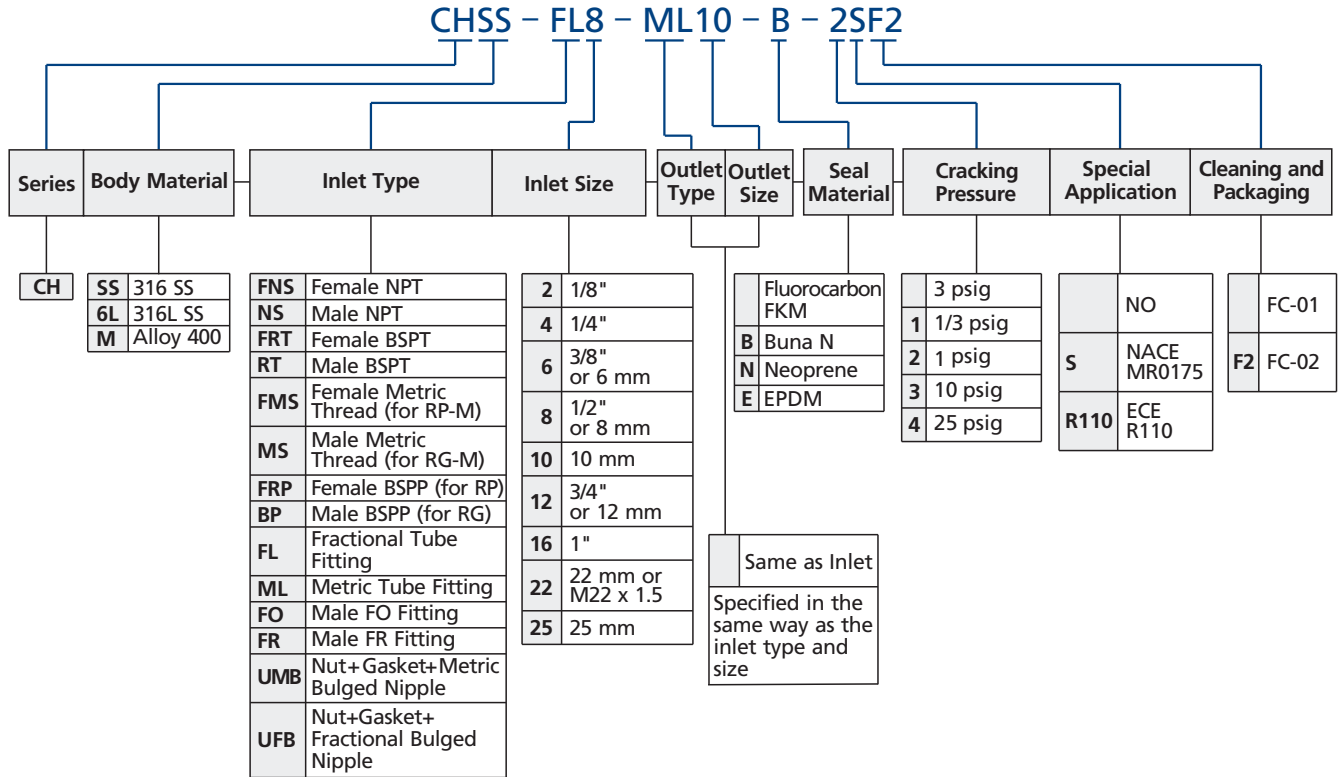

- Standard thread pitch for metric threads are as follows:
M10 and below: 1 mm
M12 to M24: 1.5 mm
M27 and above: 2 mm
Standard thread pitch should be omitted in the ordering number, others should be specified.
- For oxygen-enriched environment or hazardous media service, please contact FITOK Group or our authorized distributors.
- Cleaning and Packaging:
FC-01: Standard cleaning and packaging for general industrial procedures.
FC-02: Special cleaning and packaging for wetted system components to ensure compliance with product cleanliness requirement of ASTM G93 Level C.
- The materials, connection types and sizes listed in the "Ordering Number Description" are standard. For other materials and end connections, please contact FITOK Group or our authorized distributors.
- Check valve is designed with unidirectional flow path, it can't be used as safety relief valve.
- If the check valve is not opened for a period of time, its initial cracking pressure may be higher than set cracking pressure.

CO Series

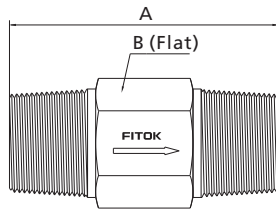

Basic Ordering Number	Connection Type and Size		Cv	Dimensions, in. (mm)	
	Inlet	Outlet		A	B
CO□□-FNS4-	1/4 Female NPT	1/4 Female NPT	0.35	2.41 (61.2)	3/4 (19.1)
CO□□-FNS8-	1/2 Female NPT	1/2 Female NPT	1.20	3.71 (94.2)	1 1/16 (27.0)
CO□□-NS4-	1/4 Male NPT	1/4 Male NPT	0.35	1.62 (41.1)	9/16 (14.3)
CO□□-NS8-	1/2 Male NPT	1/2 Male NPT	1.20	2.28 (57.9)	7/8 (22.2)
CO□□-FRT4-	1/4 Female BSPT	1/4 Female BSPT	0.35	2.54 (64.5)	3/4 (19.1)
CO□□-RT4-	1/4 Male BSPT	1/4 Male BSPT		1.62 (41.1)	9/16 (14.3)

Ordering Number Description

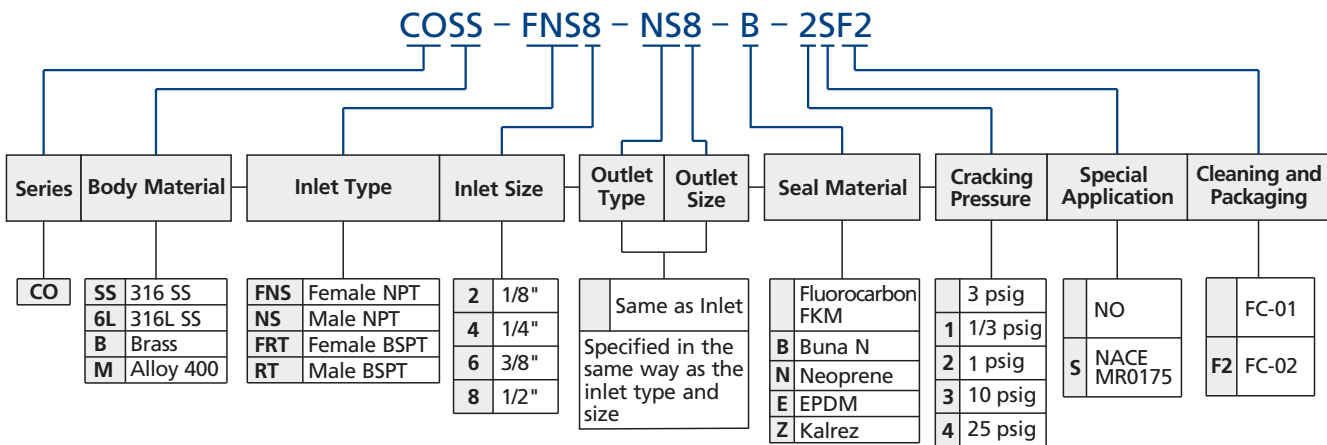

Check Valves
Relief Valves

- For oxygen-enriched environment or hazardous media service, please contact FITOK Group or our authorized distributors.
- Cleaning and Packaging:
 FC-01: Standard cleaning and packaging for general industrial procedures.
 FC-02: Special cleaning and packaging for wetted system components to ensure compliance with product cleanliness requirement of ASTM G93 Level C.
- The materials, connection types and sizes listed in the "Ordering Number Description" are standard. For other materials and end connections, please contact FITOK Group or our authorized distributors.
- Check valve is designed with unidirectional flow path, it can't be used as safety relief valve.
- If the check valve is not opened for a period of time, its initial cracking pressure may be higher than set cracking pressure.

CA Series

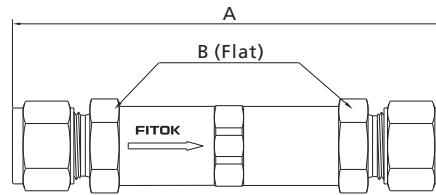

Basic Ordering Number	Connection Type and Size		Cv	Dimensions, in. (mm)	
	Inlet	Outlet		A	B
CA□□-FL4-	1/4" FITOK	1/4" FITOK	0.37	3.23 (82.0)	5/8 (15.9)
CA□□-ML6-	6 mm FITOK	6 mm FITOK		3.32 (84.3)	
CA□□-ML8-	8 mm FITOK	8 mm FITOK			
CA□□-FR4-	1/4" Male FR	1/4" Male FR		3.09 (78.5)	

Ordering Number Description

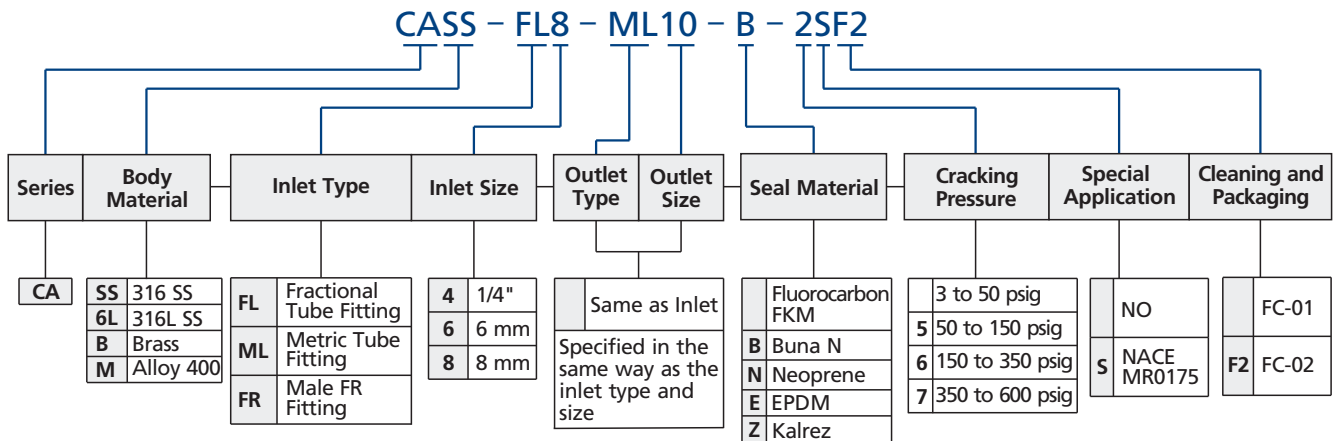

- For oxygen-enriched environment or hazardous media service, please contact FITOK Group or our authorized distributors.
- Cleaning and Packaging:
 FC-01: Standard cleaning and packaging for general industrial procedures.
 FC-02: Special cleaning and packaging for wetted system components to ensure compliance with product cleanliness requirement of ASTM G93 Level C.
- The materials, connection types and sizes listed in the "Ordering Number Description" are standard. For other materials and end connections, please contact FITOK Group or our authorized distributors.
- Check valve is designed with unidirectional flow path, it can't be used as safety relief valve.
- If the check valve is not opened for a period of time, its initial cracking pressure may be higher than set cracking pressure.

COA Series

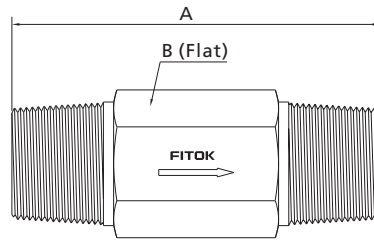

Basic Ordering Number	Connection Type and Size		CV	Dimensions, in. (mm)	
	Inlet	Outlet		A	B
COA □□-FNS4-	1/4 Female NPT	1/4 Female NPT	0.35	2.98 (75.7)	3/4 (19.1)
COA □□-NS4-	1/4 Male NPT	1/4 Male NPT	0.35	1.62 (41.1)	9/16 (14.3)
COA □□-NS8-	1/2 Male NPT	1/2 Male NPT	1.20	2.56 (65.0)	7/8 (22.2)
COA □□-RT4-	1/4 Male BSPT	1/4 Male BSPT	0.35	1.62 (41.1)	9/16 (14.3)
COA □□-RT8-	1/2 Male BSPT	1/2 Male BSPT	1.20	2.56 (65.0)	7/8 (22.2)

Ordering Number Description

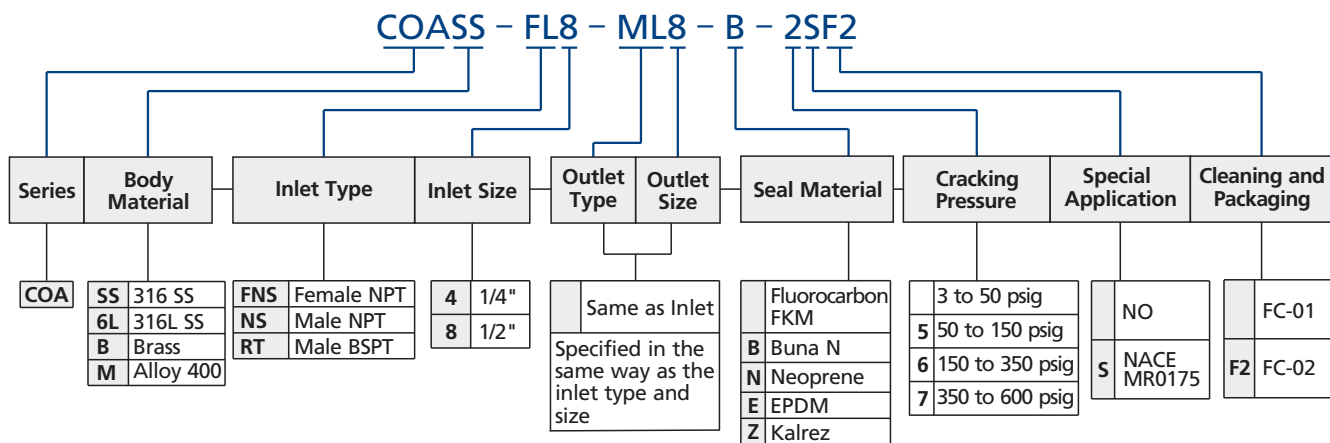

Check Valves Relief Valves

1. For oxygen-enriched environment or hazardous media service, please contact FITOK Group or our authorized distributors.
2. Cleaning and Packaging:
 FC-01: Standard cleaning and packaging for general industrial procedures.
 FC-02: Special cleaning and packaging for wetted system components to ensure compliance with product cleanliness requirement of ASTM G93 Level C.
3. The materials, connection types and sizes listed in the "Ordering Number Description" are standard. For other materials and end connections, please contact FITOK Group or our authorized distributors.
4. Check valve is designed with unidirectional flow path, it can't be used as safety relief valve.
5. If the check valve is not opened for a period of time, its initial cracking pressure may be higher than set cracking pressure.

CL Series

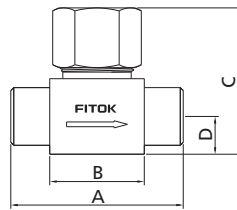

Basic Ordering Number	Connection Type and Size		Cv	Dimensions, in. (mm)			
	Inlet	Outlet		A	B	C	D
CL□□-FL4	1/4" FITOK	1/4" FITOK	0.30	2.40 (61.0)	1.01 (25.7)	1.47 (37.3)	0.39 (9.9)
CL□□-FL6	3/8" FITOK	3/8" FITOK	0.64	2.83 (71.9)	1.31 (33.3)	1.85 (47.0)	0.50 (12.7)
CL□□-FL8	1/2" FITOK	1/2" FITOK	2.20	3.92 (99.6)	2.19 (55.6)	2.44 (62.0)	0.62 (15.7)
CL□□-FL12	3/4" FITOK	3/4" FITOK					
CL□□-ML6	6 mm FITOK	6 mm FITOK	0.30	2.40 (61.0)	1.01 (25.7)	1.47 (37.3)	0.39 (9.9)
CL□□-FNS2	1/8 Female NPT	1/8 Female NPT					
CL□□-FNS4	1/4 Female NPT	1/4 Female NPT	0.64	2.25 (57.2)	1.25 (31.8)	1.85 (47.0)	0.50 (12.7)
CL□□-FNS6	3/8 Female NPT	3/8 Female NPT	2.20	3.12 (79.2)	1.86 (47.2)	2.44 (62.0)	0.62 (15.7)
CL□□-FNS8	1/2 Female NPT	1/2 Female NPT					
CL□□-TS4	1/4" TS	1/4" TS	0.30	1.81 (46.0)	0.90 (22.9)	1.47 (37.3)	0.39 (9.9)
CL□□-TS6	3/8" TS	3/8" TS	0.64	2.25 (57.2)	1.25 (31.8)	1.85 (47.0)	0.50 (12.7)
CL□□-TS8	1/2" TS	1/2" TS	2.20	3.13 (79.5)	1.88 (47.8)	2.44 (47.0)	0.62 (15.7)
CL□□-PB4	1/4 PB	1/4 PB	0.30	1.81 (46.0)	0.90 (22.9)	1.47 (37.3)	0.39 (9.9)
CL□□-PB6	3/8 PB	3/8 PB	0.64	2.25 (57.2)	1.25 (31.8)	1.85 (47.0)	0.50 (12.7)
CL□□-PB8	1/2 PB	1/2 PB	2.20	3.13 (79.5)	1.88 (47.8)	2.44 (62.0)	0.62 (15.7)

Check Valves
Relief Valves

Ordering Number Description

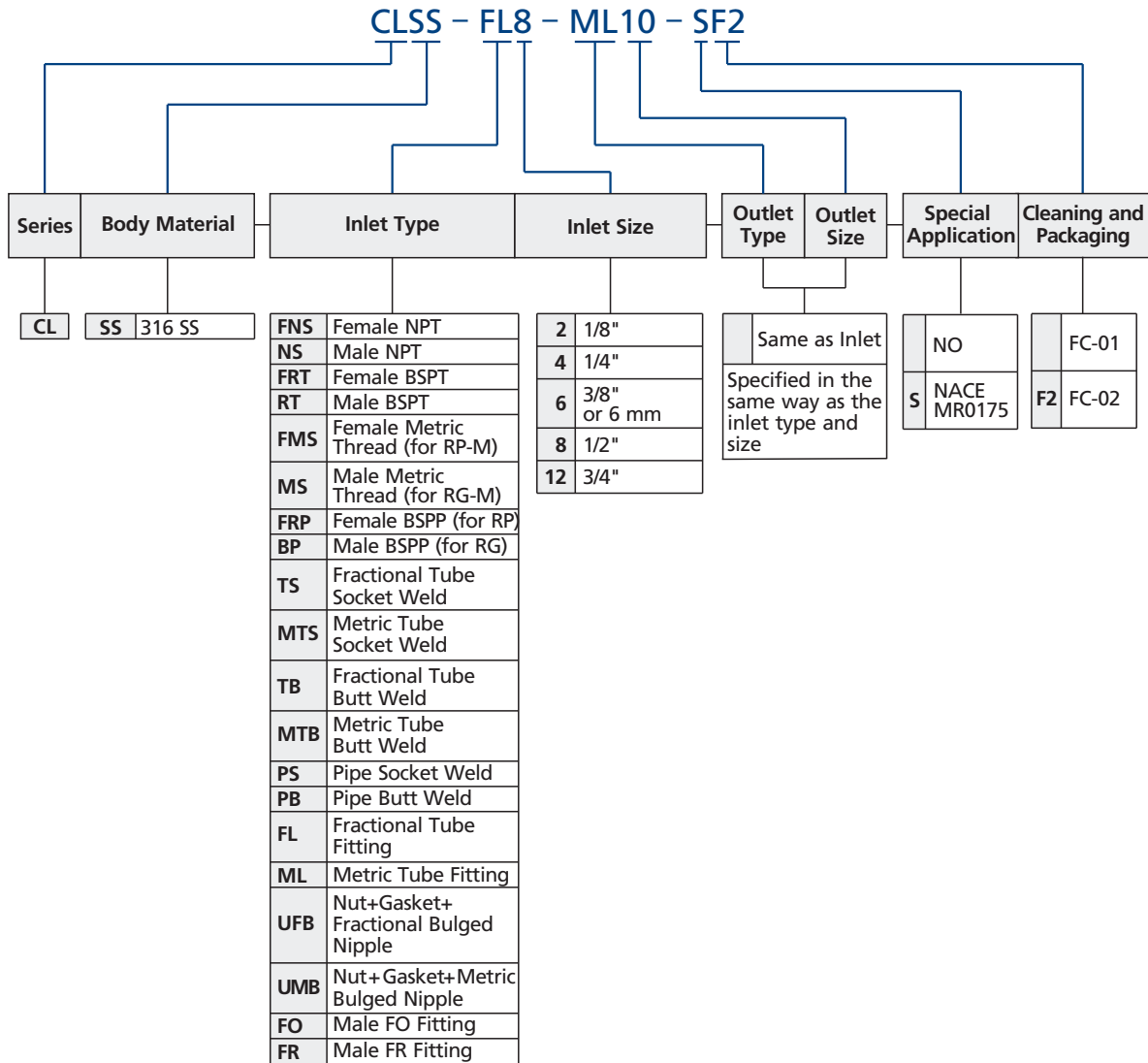

- Standard thread pitch for metric threads are as follows:
 M10 and below: 1 mm
 M12 to M24: 1.5 mm
 M27 and above: 2 mm
 Standard thread pitch should be omitted in the ordering number, others should be specified.
- For oxygen-enriched environment or hazardous media service, please contact FITOK Group or our authorized distributors.
- Cleaning and Packaging:
 FC-01: Standard cleaning and packaging for general industrial procedures.
 FC-02: Special cleaning and packaging for wetted system components to ensure compliance with product cleanliness requirement of ASTM G93 Level C.
- The materials, connection types and sizes listed in the "Ordering Number Description" are standard. For other materials and end connections, please contact FITOK Group or our authorized distributors.

Check Valves
Relief Valves

CW Series

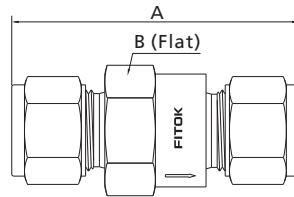

Basic Ordering Number	Connection Type and Size		Cv	Dimensions, in. (mm)	
	Inlet	Outlet		A	B
CW□□-TB4	1/4" TB	1/4" TB	0.55	1.24 (31.5)	7/8 (22.22)
CW□□-TB6	3/8" TB	3/8" TB	0.70		
CW□□-TB8	1/2" TB	1/2" TB	0.55		
CW□□-MTB6	6 mm MTB	6 mm MTB	0.55	1.80 (45.7)	1 (25.4)
CW□□-FR4	1/4" Male FR	1/4" Male FR	0.70	2.06 (52.3)	
CW□□-FR8	1/2" Male FR	1/2" Male FR	0.55	1.96 (49.8)	7/8 (22.22)
CW□□-FL4	1/4" FITOK	1/4" FITOK			
CW□□-ML6	6 mm FITOK	6 mm FITOK			

Ordering Number Description

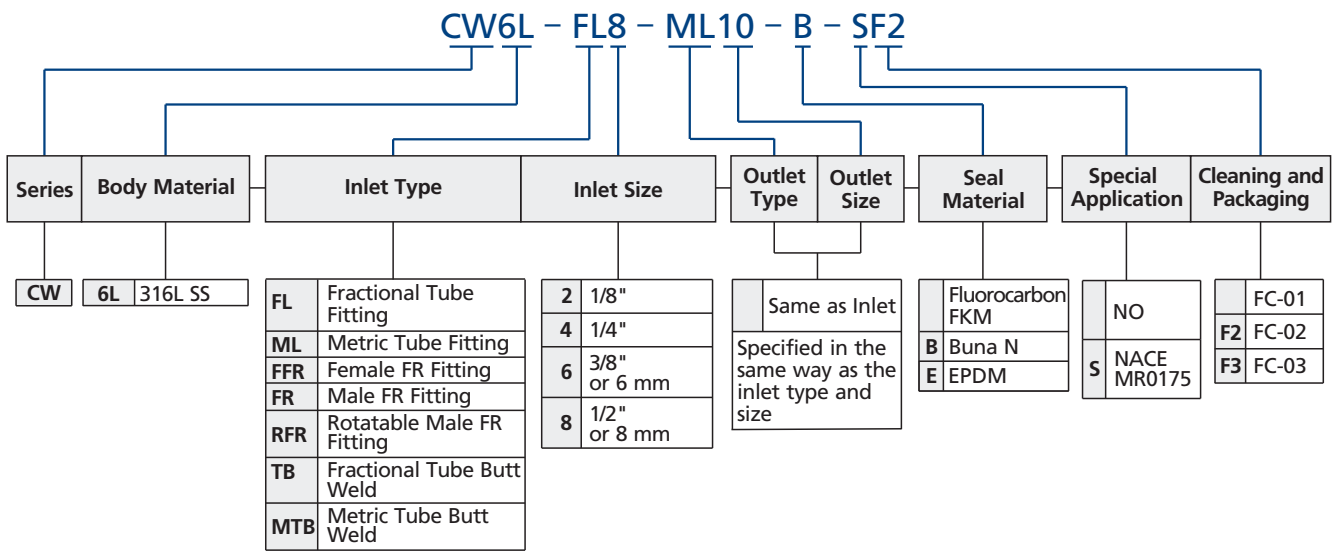

- For oxygen-enriched environment or hazardous media service, please contact FITOK Group or our authorized distributors.
- Cleaning and Packaging:
 - FC-01: Standard cleaning and packaging for general industrial procedures.
 - FC-02: Special Cleaning and packaging is applied to wetted system assembly with its surface roughness finished to an average of Ra 0.5 μm after machine polishing to meet the requirement of ASTM G93 Level C.
 - FC-03: Ultrahigh-purity Cleaning and Packaging is applied to wetted system assembly with its surface roughness finished to an average of Ra 0.2 μm after machine polishing and electropolishing.
- The materials, connection types and sizes listed in the "Ordering Number Description" are standard. For other materials and end connections, please contact FITOK Group or our authorized distributors.
- Check valve is designed with unidirectional flow path, it can't be used as safety relief valve.
- If the check valve is not opened for a period of time, its initial cracking pressure may be higher than set cracking pressure.

info@fitokgroup.com
www.fitokgroup.com

FK-IC-GV-02-EN-200810

Purge Valves

RP Series



Bleed Valves
Purge Valves

Purge Valves

RP Series

Introduction

Purge valves are manual bleed, vent or drain valves. The knurled cap is permanently assembled to the valve body for safety. One-quarter turn with a wrench from finger-tight obtains leaktight closure during initial installation. Tightening with a wrench ensures closure to the rated pressure with subsequent installations.

Features

- ⦿ Compact design for easy installation
- ⦿ Bonnet crimped to valve body to prevent accidental disassembly
- ⦿ Working pressure up to: 4000 psig (276 bar)
- ⦿ Working temperature: -65°F to 600°F (-54°C to 315°C)
- ⦿ Leak-tight performance testing with Nitrogen or compressed air for every valve at the maximum working pressure to meet the requirement of no visible leak.



Pressure vs. Temperature

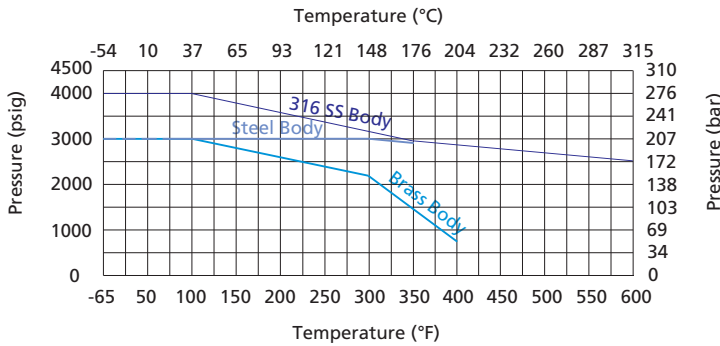

Note: Ratings based on all metal seals. Ratings limited to:
 ■ -20°F (-28°C) min with steel.
 ■ 450°F (232°C) max with SAE end connections using fluorocarbon FKM O-rings.

Standard Materials of Construction

Type L

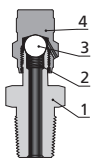

Type TL

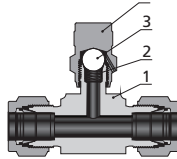

Type TA

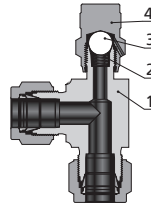

Type C

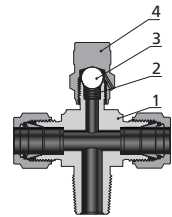

Component		Material Grade/ASTM Specification		
		316 SS	Brass	Carbon Steel
1	<i>Body</i>	<i>316 SS/A182 316 SS/A479</i>	<i>Brass C36000/B16 Brass C37700/B283</i>	<i>12L4/A108 Chromium-plated</i>
2	<i>Spring</i>	<i>302 SS/A313</i>		
3	<i>Poppet (Ball)</i>	<i>316 SS/A479</i>		
4	<i>Cap</i>	<i>316 SS/A479</i>	<i>Brass C36000/B16</i>	<i>12L4/A108 Chromium-plated</i>

Note: Wetted components are listed in italics.

1. Lubricant: molybdenum disulfide-based and silicone-based.

2. Contact FITOK Group or our authorized distributors for other materials.

Dimensions

Type L

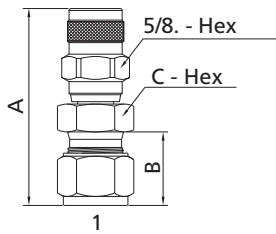

Type TL

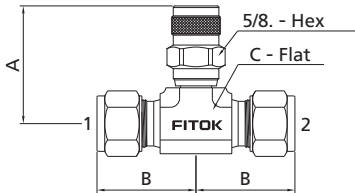

Type TA

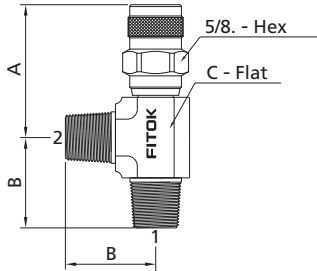

Type C

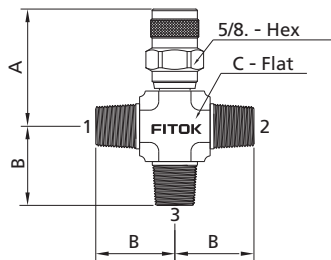

Caution:

When installing a purge valve, position the vent hole to direct system fluid away from operating personnel. Always open purge valves slowly. These valves contain no packing, so some fluid weepage will occur when the valves are opened. Operating personnel must protect themselves from exposure to system fluids.

Basic Ordering Number	Connection Type and Size		Dimensions, in. (mm)				
			A _{max}	B	C	D	
RP□□-L	-FL4	1/4" FITOK	1.96 (49.8)	0.69 (17.5)	1/2 (12.7)	5/8 (15.9)	
	-FL6	3/8" FITOK	2.05 (52.1)	0.75 (19.1)	5/8 (15.9)		
	-FL8	1/2" FITOK	2.20 (56.0)	0.88 (22.4)	13/16 (20.6)		
	-ML6	6 mm FITOK	1.96 (49.8)	0.69 (17.5)	0.55 (14.0)		
	-ML8	8 mm FITOK	2.02 (51.3)	0.73 (18.6)	0.59 (15.0)		
	-ML10	10 mm FITOK	2.10 (53.4)	0.77 (19.6)	0.71 (18.0)		
	-ML12	12 mm FITOK	2.20 (55.9)	0.87 (22.0)	0.87 (22.0)		
	-FNS4	1/4 Female NPT	1.76 (44.7)	0.72 (18.3)	3/4 (19.1)		
	-FNS6	3/8 Female NPT	1.83 (46.5)	0.78 (19.8)	7/8 (22.2)		
	-FNS8	1/2 Female NPT	2.02 (51.3)	0.97 (24.6)	1 1/16 (26.9)		
	-NS4	1/4 Male NPT	1.84 (46.8)	0.56 (14.2)	9/16 (14.3)		
	-NS6	3/8 Male NPT	1.89 (48.0)	0.56 (14.2)	11/16 (17.5)		
	-NS8	1/2 Male NPT	2.11 (53.6)	0.75 (19.1)	7/8 (22.2)		
	RP□□-TL RP□□-TA RP□□-C	-FL4	1/4" FITOK	1.41 (35.8)	1.06 (26.9)		1/2 (12.7)
		-FL6	3/8" FITOK	1.49 (37.8)	1.20 (30.5)		5/8 (15.9)
		-FL8	1/2" FITOK	1.61 (40.9)	1.42 (36.1)		13/16 (20.6)
-ML6		6 mm FITOK	1.41 (35.8)	1.06 (27.0)	1/2 (12.7)		
-ML8		8 mm FITOK	1.48 (37.7)	1.495 (29.9)	5/8 (15.9)		
-ML10		10 mm FITOK	1.52 (38.6)	1.24 (31.6)	11/16 (17.5)		
-ML12		12 mm FITOK	1.60 (40.6)	1.41 (36.0)	13/16 (20.6)		
-FNS4		1/4 Female NPT	1.66 (42.2)	1.17 (29.7)	11/16 (17.5)		
-FNS6		3/8 Female NPT	1.75 (44.4)	1.42 (36.1)	13/16 (20.6)		
-FNS8		1/2 Female NPT	1.75 (44.4)	1.56 (39.6)	1 (25.4)		
-NS4		1/4 Male NPT	1.54 (39.2)	1.05 (26.7)	1/2 (12.7)		
-NS6		3/8 Male NPT	1.68 (42.6)	1.17 (29.7)	11/16 (17.5)		
-NS8	1/2 Male NPT	1.75 (44.4)	1.45 (36.8)	13/16 (20.6)			

1. FITOK means FITOK double ferrule tube fittings.
2. Dimensions are shown with FITOK nuts finger-tightened. All dimensions are for reference only and are subject to change.
3. Sizes and types listed are standard. Other sizes and types are available upon request.

Bleed Valves
Purge Valves

Ordering Number Description



Bleed Valves
Purge Valves

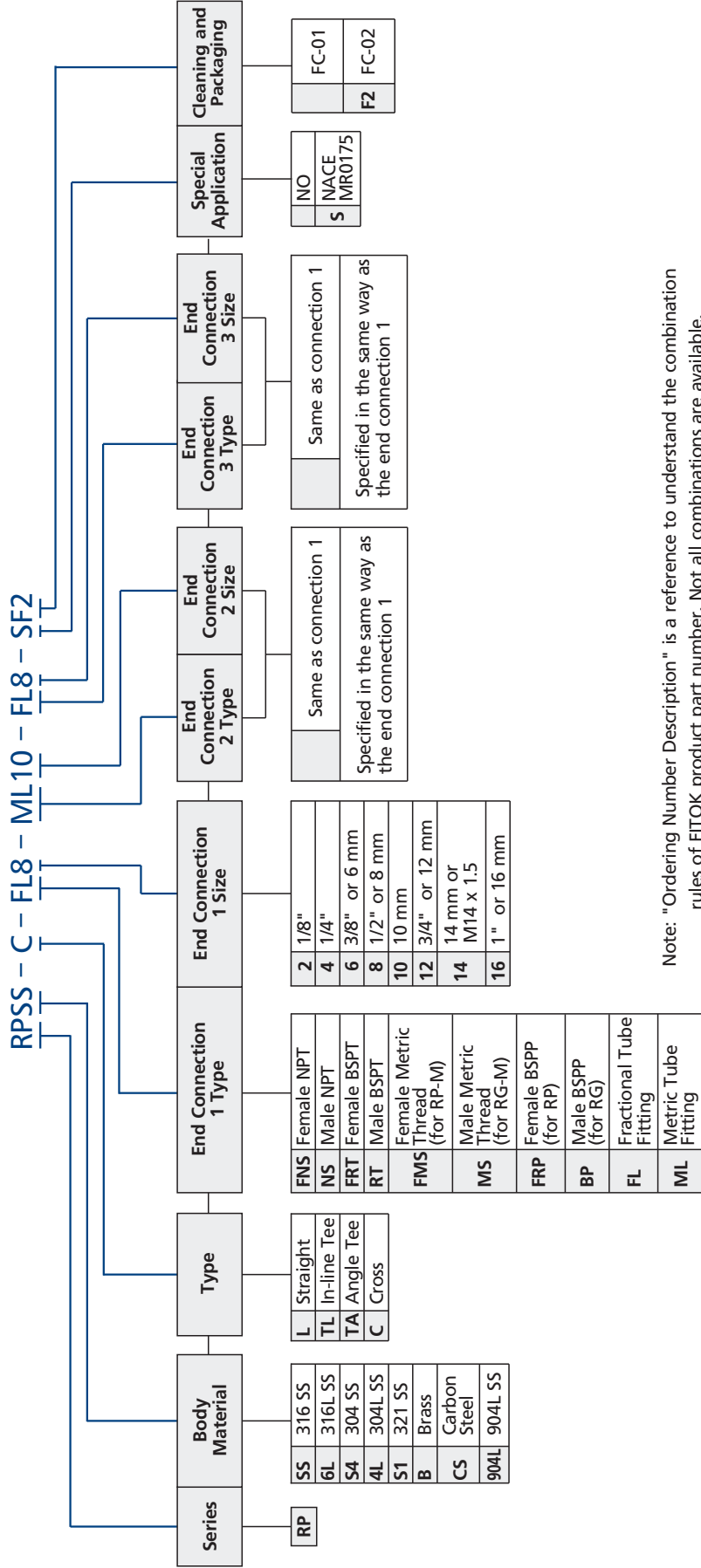

Note: "Ordering Number Description" is a reference to understand the combination rules of FITOK product part number. Not all combinations are available.

1. Standard thread pitch for metric threads are as follows:

- M10 and below: 1 mm
- M12 to M24: 1.5 mm
- M27 and above: 2 mm

Standard thread pitch should be omitted in the ordering number, others should be specified.

2. Cleaning and Packaging:

- FC-01: Standard cleaning and packaging for general industrial procedures.
- FC-02: Special cleaning and packaging for wetted system components to ensure compliance with product cleanliness requirement of ASTM G93 Level C.

Filters

FT, FB, FI and FW Series

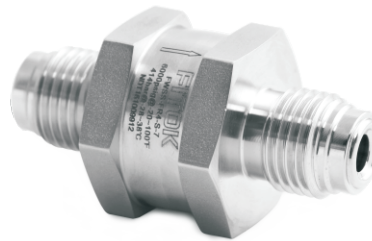

Filters

Filtration Definitions

- ⊙ Sintered element: metal powder (alloys are available) is pressed in a die at sufficient pressure that the powder particles adhere at their contact points.
- ⊙ Strainer element: the strainer is cup-shaped and includes an inner cup-shaped support structure having staggered perforations extending through the surfaces thereof, an outer cup-shaped strainer structure constructed of wire mesh is closely received over the support structure.
- ⊙ Element nominal pore size: the element nominal pore size is normally calculated from the pressure required to cause air to bubble from the largest pore in the filter element when submerged in a test liquid.

Features

Tee-type Filters

FT Series

- ⊙ Filter element replaceable without removing body from system
- ⊙ Union bonnet design
- ⊙ Nominal pore sizes for sintered element: 0.5, 2, 7, 15, 40, 60 and 80 μm
- ⊙ Nominal pore sizes for strainer element: 100, 150, 250 and 450 μm
- ⊙ Working pressure up to: 6000 psig (414 bar)
- ⊙ Working temperature: -20°F to 900°F (-28°C to 482°C)
- ⊙ Body materials: 316 SS, 316L SS, 304 SS, 304L SS, 904L SS and Brass
- ⊙ Variety of end connections available
- ⊙ ECE R110 type approved filters available

Bypass Filters

FB Series

- ⊙ Bypass port at filter bottom for the ease of sampling or purging
- ⊙ Union bonnet design
- ⊙ Nominal pore sizes for sintered element: 0.5, 2, 7, 15, 40, 60 and 80 μm
- ⊙ Nominal pore sizes for strainer element: 100, 150, 250 and 450 μm
- ⊙ Working pressure up to: 6000 psig (414 bar)
- ⊙ Working temperature: -20°F to 900°F (-28°C to 482°C)
- ⊙ Body materials: 316 SS, 316L SS, 304 SS, 304L SS, 904L SS and Brass
- ⊙ Variety of end connections available

In-line Filters

FI Series

- ⊙ Compact and space-saving design
- ⊙ Nominal pore sizes for sintered element: 0.5, 2, 7, 15, 40, 60 and 80 μm
- ⊙ Nominal pore sizes for strainer element: 100, 150, 250 and 450 μm
- ⊙ Working pressure up to: 3000 psig (207 bar)
- ⊙ Working temperature: -20°F to 900°F (-28°C to 482°C)
- ⊙ Body materials: 316 SS, 316L SS, 304 SS, 304L SS, 321 SS, 904L SS and Brass
- ⊙ Variety of end connections available

All-welded In-line Filters

FW Series

- ⊙ Large filtration area and high flow coefficient
- ⊙ All-welded construction for elimination of leakage
- ⊙ Easy cleaning of filters by backflushing
- ⊙ Full-penetration weld between body and filter element
- ⊙ Nominal pore sizes for sintered element: 0.5 μm
- ⊙ Nominal pore sizes for strainer element: 2, 7, 15 and 40 μm
- ⊙ Working pressure up to: 6000 psig (414 bar)
- ⊙ Working temperature: -20°F to 900°F (-28°C to 482°C)
- ⊙ Body materials: 316 SS, 316L SS, 304 SS, 304L SS and 904L SS
- ⊙ Variety of end connections available

Pressure vs. Temperature

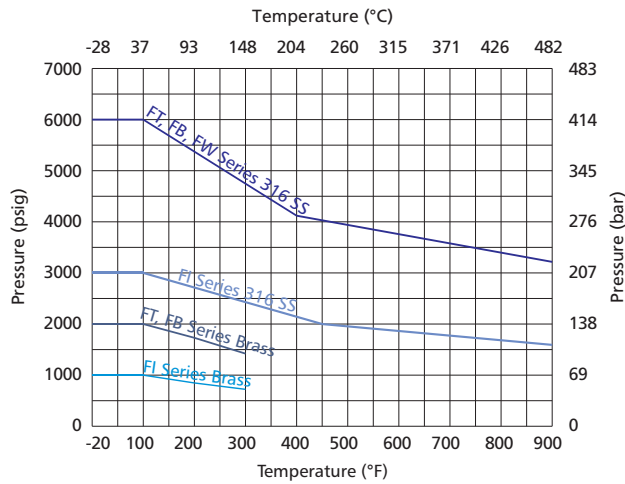

Contact FITOK Group or our authorized distributors for curve graph of other materials.

FT Series

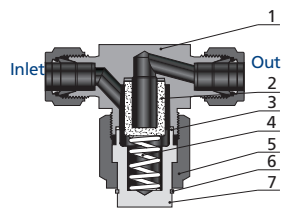

FB Series

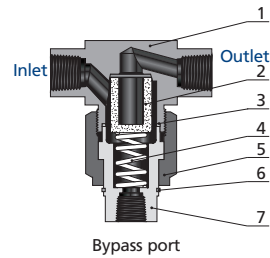

FI Series

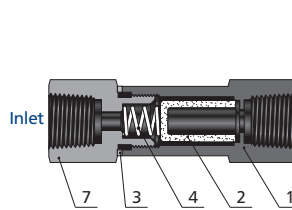

FW Series

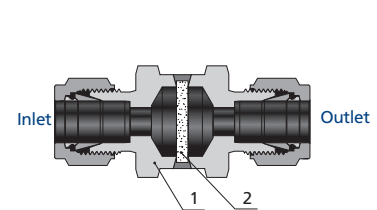

Standard Materials of Construction

Component		Material Grade/ASTM Specification	
		316 SS	Brass
1	Body	F316 SS/A182 (FT, FB Series), 316 SS/A479 (FI, FW Series)	Brass C37700/B283 (FT, FB Series) Brass C36000/B16 (FI Series)
2	Element	Sintered 316 SS or strainer 316 SS	Sintered 316 SS or strainer 316 SS
3	Gasket	316 SS/A479 with PTFE/D1710 coating or silver-plated	PTFE/D1710 or aluminum/B209
4	Spring	302 SS/A313	302 SS/A313
5	Bonnet Nut	316 SS/A479	C36000/B16
6	Backup Ring	Stainless steel	
7	Bonnet	316 SS/A479	C36000/B16

1. FW Series filters not available in brass

2. Lubricants: molybdenum disulfide-based and silicone-based

Maximum Differential Pressure of Clean Filter at 70°F (20°C)

Series	Maximum Differential Pressure psig (bar)											
	0.5 micron	2 micron	7 micron	15 micron	40 micron	60 micron	80 micron	100 micron	150 micron	250 micron	450 micron	
FT, FB, FI	1000 (69.0)											
FW	600 (41.4)	100 (6.9)		—								

Filter Elements

Filter elements remove 95 % of particles larger than the nominal pore size.

Nominal Pore Size μm	Pore Size Range μm	Element Type
0.5	0.5 to 2	Sintered
2	1 to 4	Sintered or Strainer
7	5 to 10	
15	11 to 25	
40	35 to 53	
60	50 to 75	
80	70 to 95	
100	—	Strainer
150	—	
250	—	
450	—	

Filtration Area

Series	Orifice in. (mm)	Filtration Area in. ² (mm ²)	
		Sintered	Strainer
2FT, 2FB	0.09 (2.0)	1.30 (830)	1.00 (640)
4FT, 4FB	0.17 (4.4)	1.30 (830)	1.00 (640)
8FT, 8FB	0.25 (6.4)	2.00 (1280)	1.70 (1090)
2FI	0.09 (2.4)	0.55 (350)	—
4FI	0.19 (4.8)	1.30 (830)	1.00 (640)
8FI	0.28 (7.1)	2.00 (1280)	1.70 (1090)
4FW	0.19 (4.8)	0.39 (254)	0.39 (254)

CNG/NGV Application

FT Series Filters with ECE R110 Type Approval (Class 0) are available.

Temperature: -40 to 248°F (-40 to 120°C)

Pressure: 3370 psig (260 bar)

To order, add **-R110** to the filter ordering number.

Example: FTSS-FL4-15-**R110**

Dimensions

FT Series

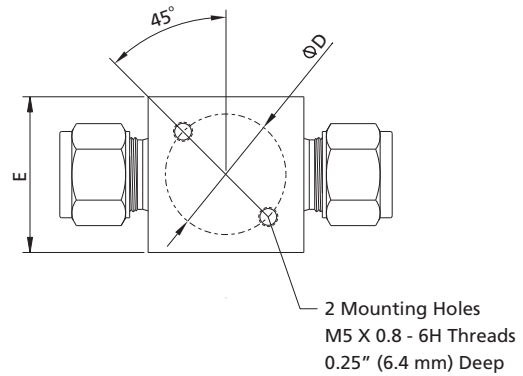
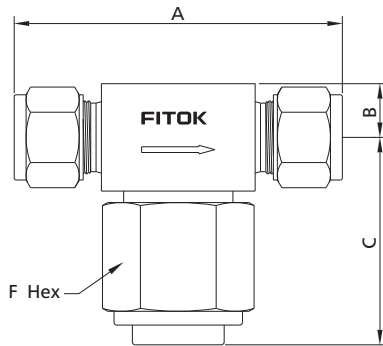

Basic Ordering Number	Connection Type and Size		Element Series	Filter Series	Dimensions, in. (mm)					
	Inlet	Outlet			A	B	C	ØD	E	F
FT□□-FL2-	1/8" FITOK	1/8" FITOK	4	4FT	2.27 (57.7)	0.38 (9.7)	1.49 (37.8)	1.00 (25.4)	1.00 (25.4)	1 (25.4)
FT□□-FL4-	1/4" FITOK	1/4" FITOK	4	4FT	2.47 (62.7)					
FT□□-FL6-	3/8" FITOK	3/8" FITOK	8	8FT	2.84 (72.1)	0.46 (11.7)	1.74 (44.2)	1.13 (28.7)	1.13 (28.7)	1 1/8 (28.6)
FT□□-FL8-	1/2" FITOK	1/2" FITOK	8	8FT	3.04 (77.2)					
FT□□-ML6-	6 mm FITOK	6 mm FITOK	4	4FT	2.46 (62.5)	0.38 (9.7)	1.49 (37.8)	1.00 (25.4)	1.00 (25.4)	1 (25.4)
FT□□-ML8-	8 mm FITOK	8 mm FITOK	8	8FT	2.84 (72.1)					
FT□□-ML10-	10 mm FITOK	10 mm FITOK	8	8FT	2.86 (72.6)	0.46 (11.7)	1.74 (44.2)	1.13 (28.7)	1.13 (28.7)	1 1/8 (28.6)
FT□□-ML12-	12 mm FITOK	12 mm FITOK	8	8FT	3.04 (77.2)					
FT□□-TS4-	1/4" TS	1/4" TS	4	4FT	1.68 (42.7)	0.38 (9.7)	1.49 (37.8)	1.00 (25.4)	1.00 (25.4)	1 (25.4)
FT□□-TS6-	3/8" TS	3/8" TS	4	4FT						
FT□□-TB4-	1/4" TB	1/4" TB	4	4FT						
FT□□-TB6-	3/8" TB	3/8" TB	4	4FT						
FT□□-FNS2-	1/8 Female NPT	1/8 Female NPT	4	4FT	2.00 (50.8)	0.38 (9.7)	1.49 (37.8)	1.00 (25.4)	1.00 (25.4)	1 (25.4)
FT□□-FNS4-	1/4 Female NPT	1/4 Female NPT	4	4FT	2.13 (54.1)					
FT□□-NS4-	1/4 Male NPT	1/4 Male NPT	4	4FT	2.38 (60.5)	0.46 (11.7)	1.74 (44.2)	1.13 (28.7)	1.13 (28.7)	1 1/8 (28.6)
FT□□-NS6-	3/8 Male NPT	3/8 Male NPT	8	8FT						
FT□□-NS8-	1/2 Male NPT	1/2 Male NPT	8	8FT	2.75 (69.9)	0.38 (9.7)	1.49 (37.8)	1.00 (25.4)	1.00 (25.4)	1 (25.4)
FT□□-FR4-	1/4 Male FR	1/4 Male FR	4	4FT	2.30 (58.4)					
FT□□-FR8-	1/2 Male FR	1/2 Male FR	8	8FT	2.55 (64.8)	0.46 (11.7)	1.74 (44.2)	1.13 (28.7)	1.13 (28.7)	1 1/8 (28.6)

Mounting holes not available with 1/4 female NPT end connections

Filters

B-180 Filters

FB Series

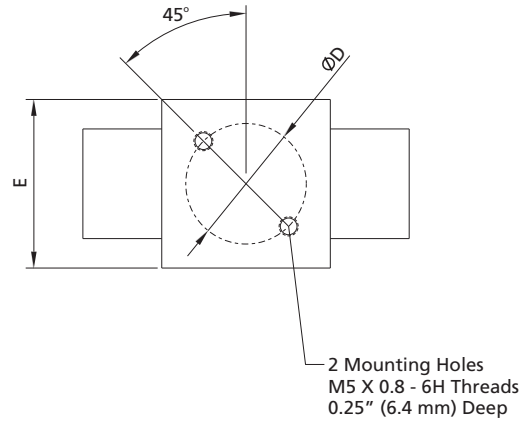
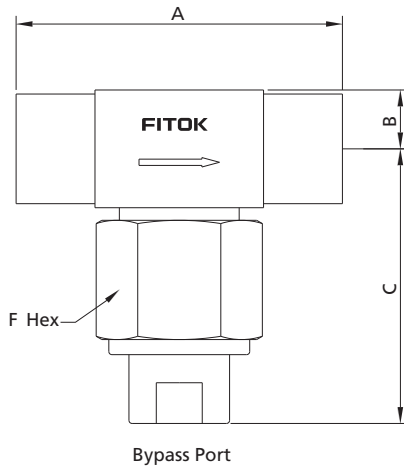

Basic Ordering Number	Connection Type and Size		Element Series	Filter Series	Dimensions, in. (mm)						
	Inlet	Outlet			A	B	C	ØD	E	F	Bypass Port
FB□□-FL2-	1/8" FITOK	1/8" FITOK	4	4FB	2.27 (57.7)	0.38 (9.7)	1.98 (50.2)	1.00 (25.4)	1.00 (25.4)	1 (25.4)	FL2
FB□□-FL4-	1/4" FITOK	1/4" FITOK	4	4FB	2.47 (62.7)		2.44 (61.9)				FL4
FB□□-FL6-	3/8" FITOK	3/8" FITOK	8	8FB	2.84 (72.1)	0.46 (11.7)	2.74 (69.1)	1.13 (28.7)	1.13 (28.7)	1 1/8 (28.6)	FL6
FB□□-FL8-	1/2" FITOK	1/2" FITOK	8	8FB	3.04 (77.2)		2.96 (74.2)				FL8
FB□□-ML6-	6 mm FITOK	6 mm FITOK	4	4FB	2.46 (62.5)	0.38 (9.7)	2.44 (61.9)	1.00 (25.4)	1.00 (25.4)	1 (25.4)	FL4
FB□□-ML8-	8 mm FITOK	8 mm FITOK	8	8FB	2.84 (72.1)	0.46 (11.7)	2.74 (69.1)	1.13 (28.7)	1.13 (28.7)	1 1/8 (28.6)	FL6
FB□□-ML10-	10 mm FITOK	10 mm FITOK	8	8FB	2.86 (72.6)		2.96 (74.2)				FL8
FB□□-ML12-	12 mm FITOK	12 mm FITOK	8	8FB	3.04 (77.2)						
FB□□-TS4-	1/4" TS	1/4" TS	4	4FB	1.68 (42.7)	0.38 (9.7)	1.83 (56.4)	1.00 (25.4)	1.00 (25.4)	1 (25.4)	TB4
FB□□-TS6-	3/8" TS	3/8" TS	4	4FB							
FB□□-TB4-	1/4" TB	1/4" TB	4	4FB							
FB□□-TB6-	3/8" TB	3/8" TB	4	4FB							
FB□□-FNS2-	1/8 Female NPT	1/8 Female NPT	4	4FB	2.00 (50.8)	0.38 (9.7)	1.71 (43.4)	1.00 (25.4)	1.00 (25.4)	1 (25.4)	FNS2
FB□□-FNS4-	1/4 Female NPT	1/4 Female NPT	4	4FB	2.13 (54.1)						
FB□□-NS4-	1/4 Male NPT	1/4 Male NPT	4	4FB							
FB□□-NS6-	3/8 Male NPT	3/8 Male NPT	8	8FB	2.38 (60.5)	0.46 (11.7)	2.00 (50.8)	1.13 (28.7)	1.13 (28.7)	1 1/8 (28.6)	FL4
FB□□-NS8-	1/2 Male NPT	1/2 Male NPT	8	8FB	2.75 (69.9)						
FB□□-FR4-	1/4 Male FR	1/4 Male FR	4	4FB	2.38 (60.5)	0.38 (9.7)	2.44 (61.9)	1.00 (25.4)	1.00 (25.4)	1 (25.4)	FL4
FB□□-FR8-	1/2 Male FR	1/2 Male FR	8	8FB	2.75 (69.9)	0.46 (11.7)	2.96 (74.2)	1.13 (28.7)	1.13 (28.7)	1 1/8 (28.6)	FL8

Mounting holes not available with 1/4 female NPT end connections

FI Series

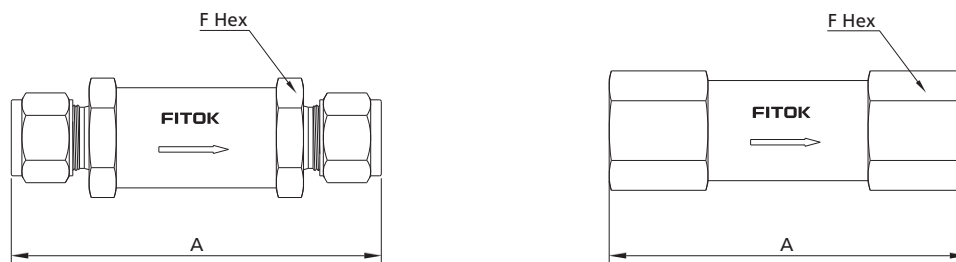

Basic Ordering Number	Connection Type and Size		Element Series	Filter Series	Dimensions in. (mm)	
	Inlet	Outlet			A	F
FI□□-FL2-	1/8" FITOK	1/8" FITOK	2	2FI	2.35 (59.7)	9/16 (14.3)
FI□□-FL4-	1/4" FITOK	1/4" FITOK	4	4FI	2.95 (74.9)	3/4 (19.1)
FI□□-FL6-	3/8" FITOK	3/8" FITOK	8	8FI	3.21 (81.5)	1 (25.4)
FI□□-FL8-	1/2" FITOK	1/2" FITOK	8	8FI	3.49 (88.6)	
FI□□-ML3-	3 mm FITOK	3 mm FITOK	2	2FI	2.38 (60.5)	9/16 (14.3)
FI□□-ML6-	6 mm FITOK	6 mm FITOK	4	4FI	2.96 (75.2)	3/4 (19.1)
FI□□-FNS2-	1/8 Female NPT	1/8 Female NPT	2	2FI	2.16 (54.9)	9/16 (14.3)
FI□□-FNS4-	1/4 Female NPT	1/4 Female NPT	4	4FI	2.87 (72.9)	3/4 (19.1)
FI□□-NS2-	1/8 Male NPT	1/8 Male NPT	2	2FI	1.88 (47.7)	9/16 (14.3)
FI□□-NS4-	1/4 Male NPT	1/4 Male NPT	4	4FI	2.69 (68.3)	3/4 (19.1)
FI□□-FR2-	1/8 Male FR	1/8 Male FR	2	2FI	2.79 (70.8)	
FI□□-FR4-	1/4 Male FR	1/4 Male FR	4	4FI		
FI□□-FRT2-	1/8 Female BSPT	1/8 Female BSPT	2	2FI	2.16 (54.9)	9/16 (14.3)
FI□□-FRT4-	1/4 Female BSPT	1/4 Female BSPT	4	4FI	2.87 (72.9)	3/4 (19.1)
FI□□-RT2-	1/8 Male BSPT	1/8 Male BSPT	2	2FI	1.88 (47.7)	9/16 (14.3)
FI□□-RT4-	1/4 Male BSPT	1/4 Male BSPT	4	4FI	2.69 (68.3)	3/4 (19.1)

FW Series

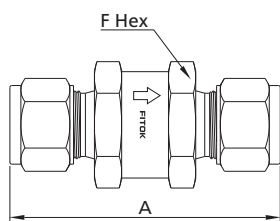

Basic Ordering Number	Connection Type and Size		Orifice in. (mm)	Dimensions in. (mm)	
	Inlet	Outlet		A	F
FW□□-FL4-	1/4" FITOK	1/4" FITOK	0.19 (4.75)	2.15 (54.6)	1 (25.4)
FW□□-ML6-	6 mm FITOK	6 mm FITOK			
FW□□-FNS4-	1/4 Female NPT	1/4 Female NPT	0.45 (11.5)	1.57 (39.9)	
FW□□-NS4-	1/4 Male NPT	1/4 Male NPT	0.28 (7.14)	1.89 (48.0)	
FW□□-FR4-	1/4 Male FR	1/4 Male FR	0.19 (4.75)	2.04 (51.8)	

1. FITOK means FITOK double ferrule tube fittings, FR means metal gasket seal fittings, TS means fractional tube socket weld, TB means fractional tube butt weld.
2. Sizes and types listed are standard. Other sizes and types are available upon request.
3. Dimensions are shown with FITOK nuts finger-tightened. All dimensions are for reference only and are subject to change. For dimensions not shown above, please contact FITOK Group or our authorized distributors.

Filters Ordering Number Description

FBSS – FL8 – ML10 – S – P150 – FL4SF2

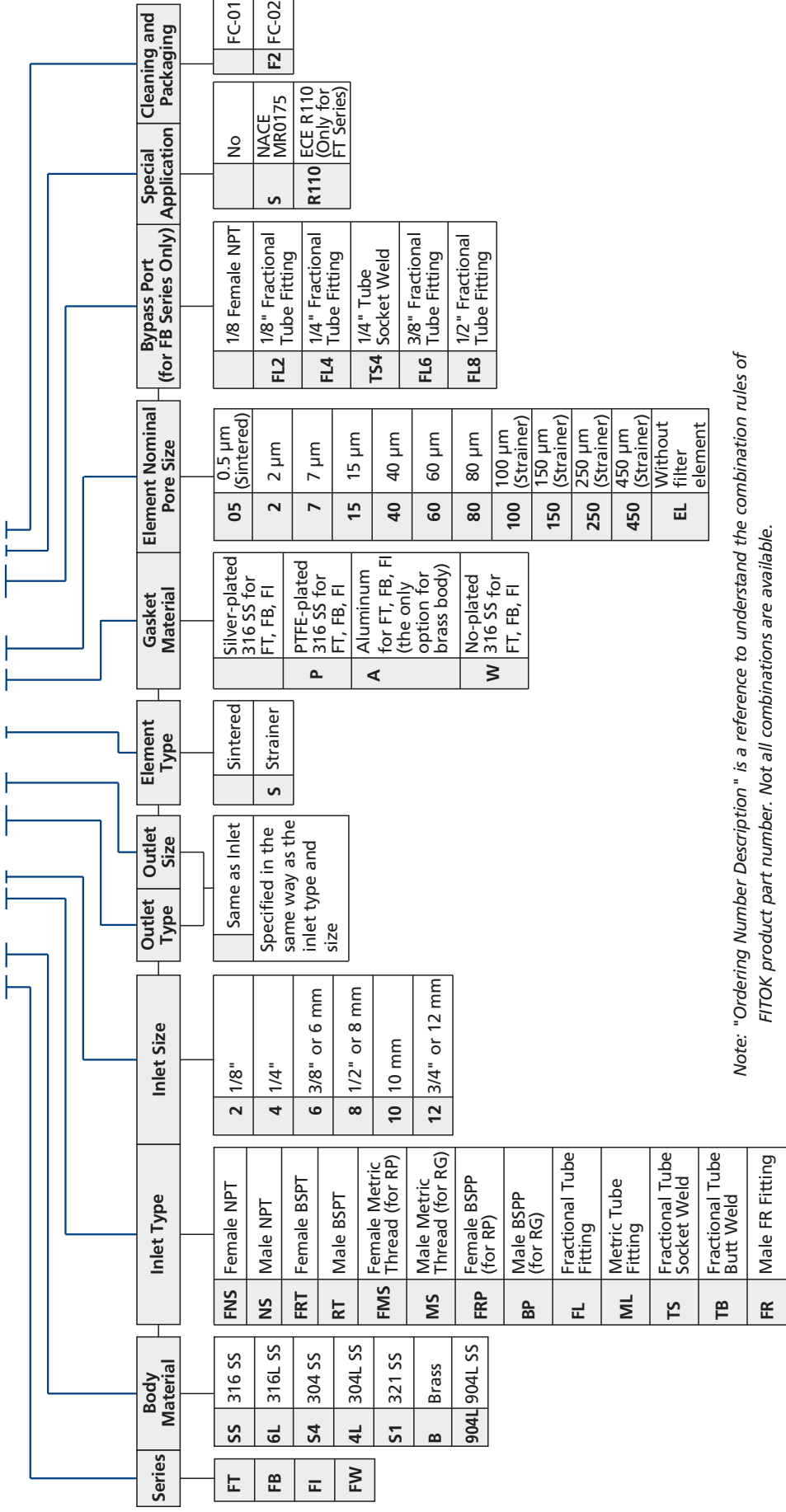

Note: "Ordering Number Description" is a reference to understand the combination rules of FITOK product part number. Not all combinations are available.

- Standard thread pitch for metric threads are as follows:
 M10 and below: 1 mm
 M12 to M24: 1.5 mm
 M27 and above: 2 mm
 Standard thread pitch should be ignored in the ordering number, others should be specified.
- Cleaning and Packaging:
 FC-01 Standard cleaning and packaging for basic industrial procedures.
 FC-02 Special cleaning and packaging for wetted system components to ensure compliance requirement as stated in ASTM G93 Level C.

Elements Ordering Number Description

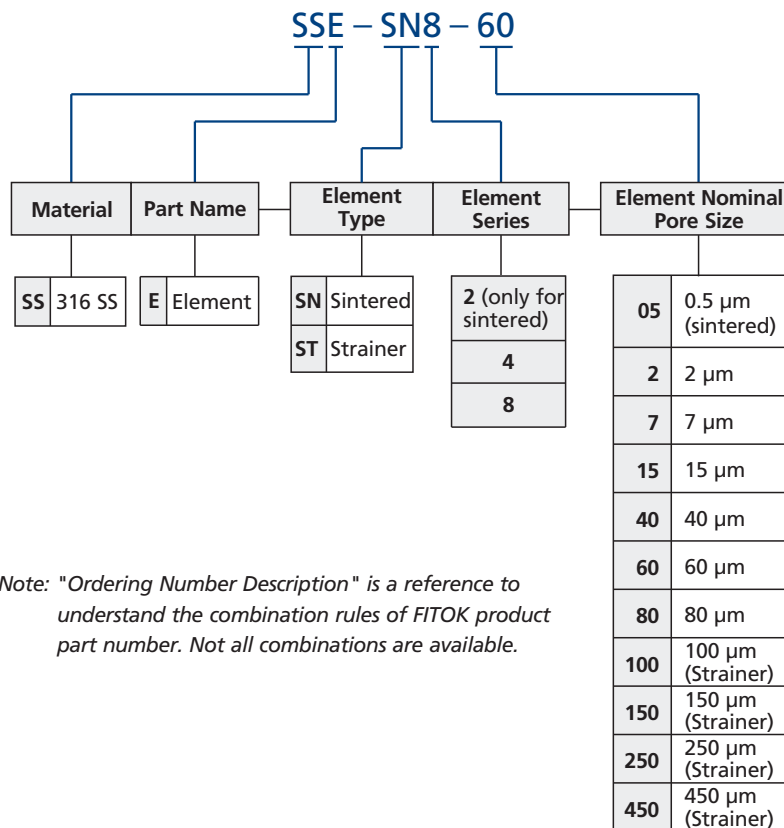

Note: "Ordering Number Description" is a reference to understand the combination rules of FITOK product part number. Not all combinations are available.

info@fitokgroup.com
www.fitokgroup.com

FK-IC-GV-13-EN-200430

Gauge Valves and Instrumentation Manifolds

GV, GVH, GR Series

2-valve, 3-valve and 5-valve Manifold Series

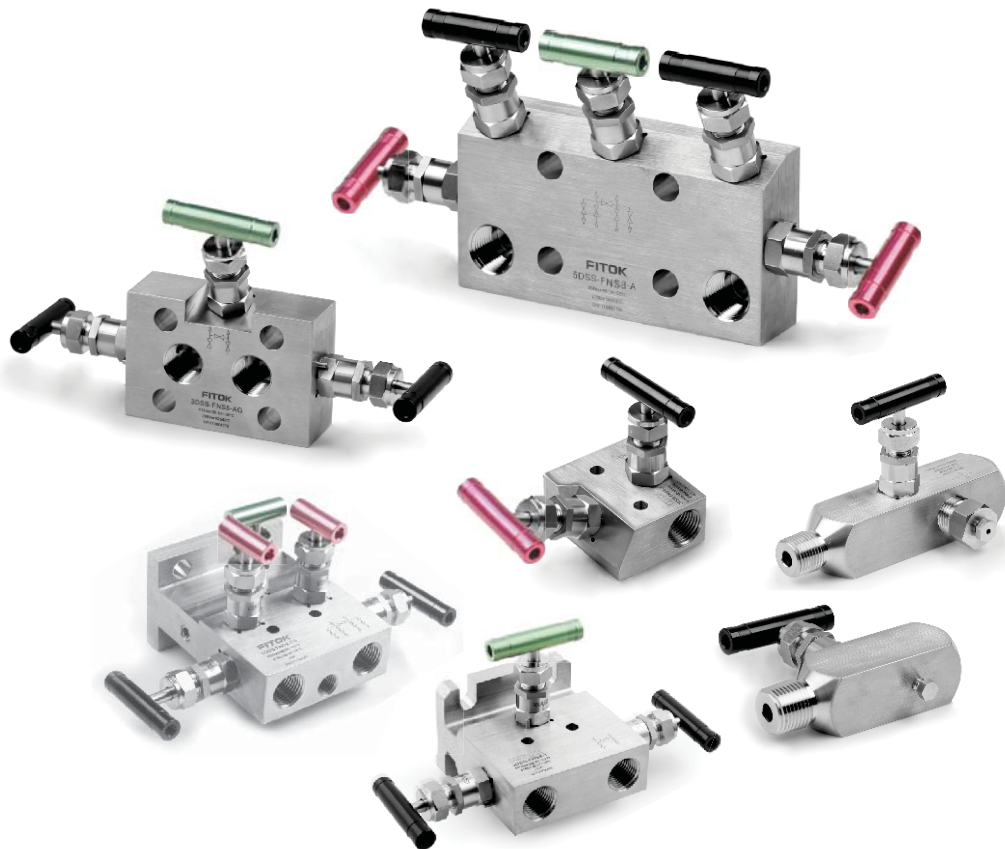

Manifolds

Contents

Gauge Valves

GV Series, GVH Series and GR Series

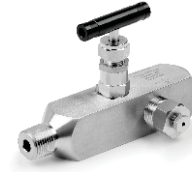

C-04

Instrumentation Manifolds

2-valve Manifolds



C-09

3-valve Manifolds

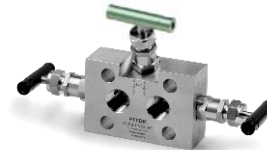

C-12

5-valve Manifolds



C-14

C Integral Manifolds

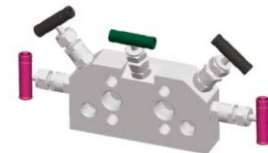

C-18

Accessories

Manifold Bracket Supports

C-21

Kidney Flange / Eccentric Flange

C-21

Bleed Valves

C-22

Calibration Fittings

C-22

Gauge Valves

GV Series, GVH Series and GR Series

Features

- ⦿ Working pressure up to:
 - Stainless steel: GV, GR up to 6000 psig (414 bar)
 - GVH up to 10000 psig (690 bar)
- ⦿ GV Series and GVH Series working temperature:
 - PTFE packing: -65°F to 450°F (-54°C to 232°C)
 - Graphite packing: -65°F to 1200°F (-54°C to 649°C)
- ⦿ GR Series working temperature:
 - Acetal seat: -20°F to 250°F (-28°C to 121°C)
 - PEEK seat: -20°F to 400°F (-28°C to 204°C)
- ⦿ Non-rotating lower stem, ball tip and plug tip designs
- ⦿ Variety of materials for seat and packing
- ⦿ Safety back seating seals in fully open position
- ⦿ Rolled spindle operating threads
- ⦿ Lubricant for stem thread isolated from the media
- ⦿ Externally adjustable gland
- ⦿ Bonnet locking pin fitted as standard
- ⦿ Low torque operating T bar handle
- ⦿ Option for different colored handles
- ⦿ Steady and durable fastening of the handle by double lock-pins
- ⦿ Each GV/GR Series gauge valve leak tested with Nitrogen or compressed air at the maximum working pressure, each GVH Series gauge valve leak tested with water at 1.1 times the maximum working pressure

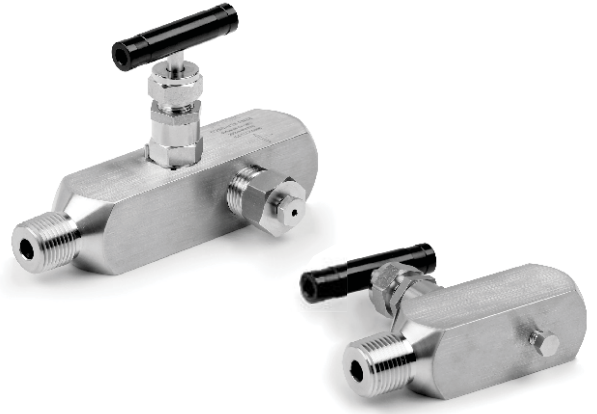

Standard Materials of Construction

Item	Component	Valve Body Material
		Material Grade/ASTM Specification
		316 SS
1	Handle	6061/B211
2	Set Screw	Stainless steel
3	Packing Bolt	304 SS/A479
4	Upper Stem	316 SS/A479
5	Lock Nut	Stainless steel
6	Bonnet	316 SS/A479
7	Gland	316 SS/A479
8	Packing	PTFE or graphite
9	Lock Pin	Stainless steel
10	Lower Stem	Hardened 316 SS/A479
11	Body	316 SS/A479 316 SS/A182
12	Seat	Acetal or PEEK
	Lubricant	Molybdenum disulfide-based

Ball Tip Design Valves (GV, GVH)

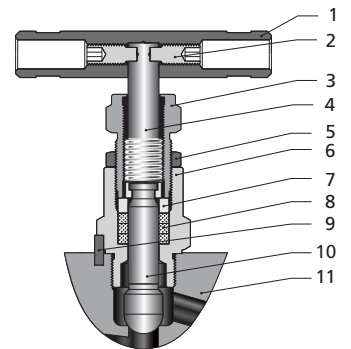

Plug Tip Design Valves (GR)

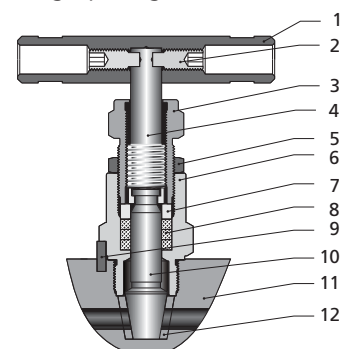

Process interface valves for sour gas service are available. Materials are selected in accordance with NACE MR0175/ISO 15156. Contact FITOK Group or our authorized distributors if you have any request.

Pressure vs. Temperature

GV Series Ball Tip Design Gauge Valves

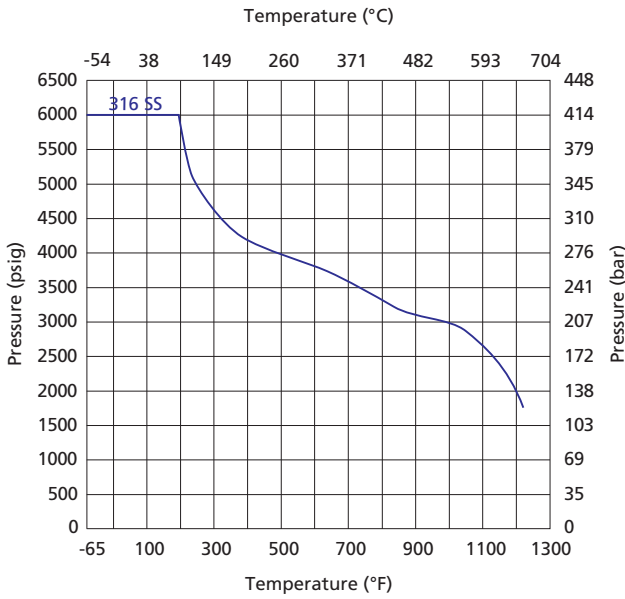

GVH Series Ball Tip Design Gauge Valves

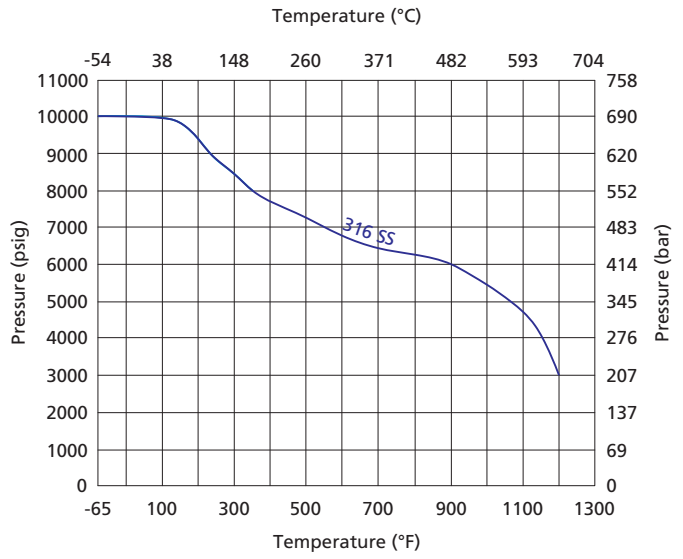

Based on graphite packing.

GR Series Plug Tip Design Gauge Valves

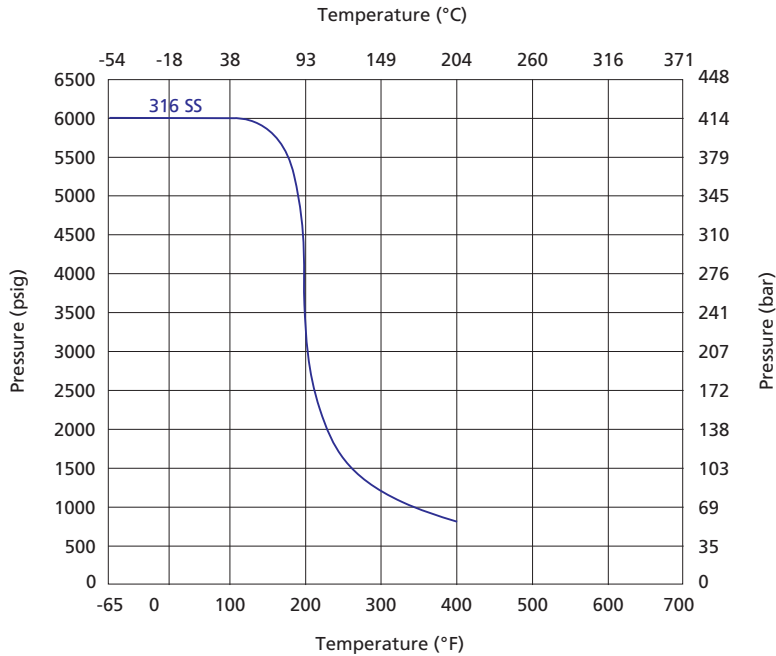

1. For manifolds of Acetal seat, the maximum medium temperature is 250°F (121°C), not recommended for temperature higher than 200°F (93°C) for water and steam application.
2. Based on PEEK seat and PTFE packing.

Types and Dimensions

Standard Type

Basic Ordering Number	Design	Inlet/Process	Outlet/Instrument	Test/Vent/Plug
GV □□-NS8-FNS8	Ball Tip	1/2 Male NPT	1/2 Female NPT	1/2 Female NPT
GVH □□-NS8-FNS8				
GR □□-NS8-FNS8	Plug Tip			
GV □□-NS12-FNS8	Ball Tip	3/4 Male NPT	1/2 Female NPT	1/2 Female NPT
GVH □□-NS12-FNS8				
GR □□-NS12-FNS8	Plug Tip			

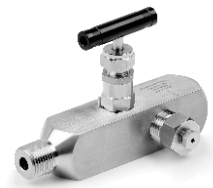
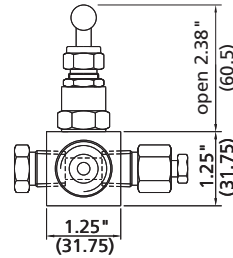
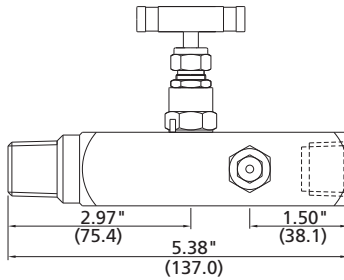
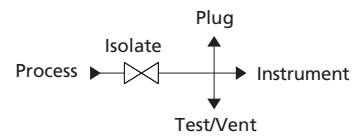

The dimensions shown are for GV series gauge valves. If you need the dimensions of GVH series, please contact FITOK Group.

Lagging Extension Body Type

Basic Ordering Number	Inlet/Process	Outlet/Instrument	Test/Vent/Plug
GV □□-NS8-FNS8-E	1/2 Male NPT	1/2 Female NPT	1/2 Female NPT
GVH □□-NS8-FNS8-E			
GR □□-NS8-FNS8-E			

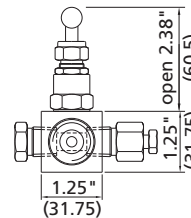
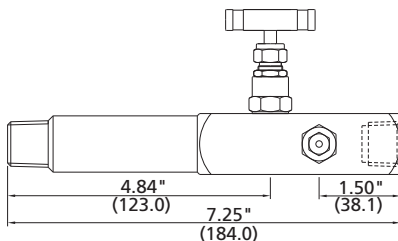
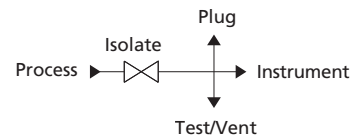

Lagging extension body is inserted through pipe insulation.

The dimensions shown are for GV series gauge valves. If you need the dimensions of GVH series, please contact FITOK Group.

Miniature Type

Basic Ordering Number	Inlet/Process	Outlet/Instrument	Vent
GV □□-NS8-FNS8-C	1/2 Male NPT	1/2 Female NPT	Vent stem
GVH □□-NS8-FNS8-C			
GR □□-NS8-FNS8-C			

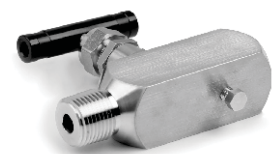
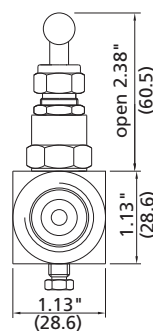
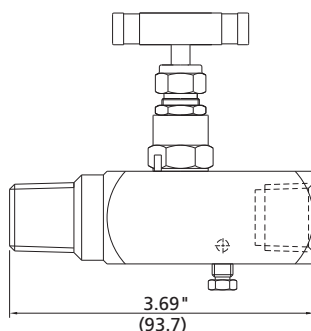
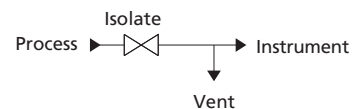

The dimensions shown are for GV series gauge valves. If you need the dimensions of GVH series, please contact FITOK Group.

Ordering Number Description

GRSS – NS8 – FNS8 – CPW – GR – SF2

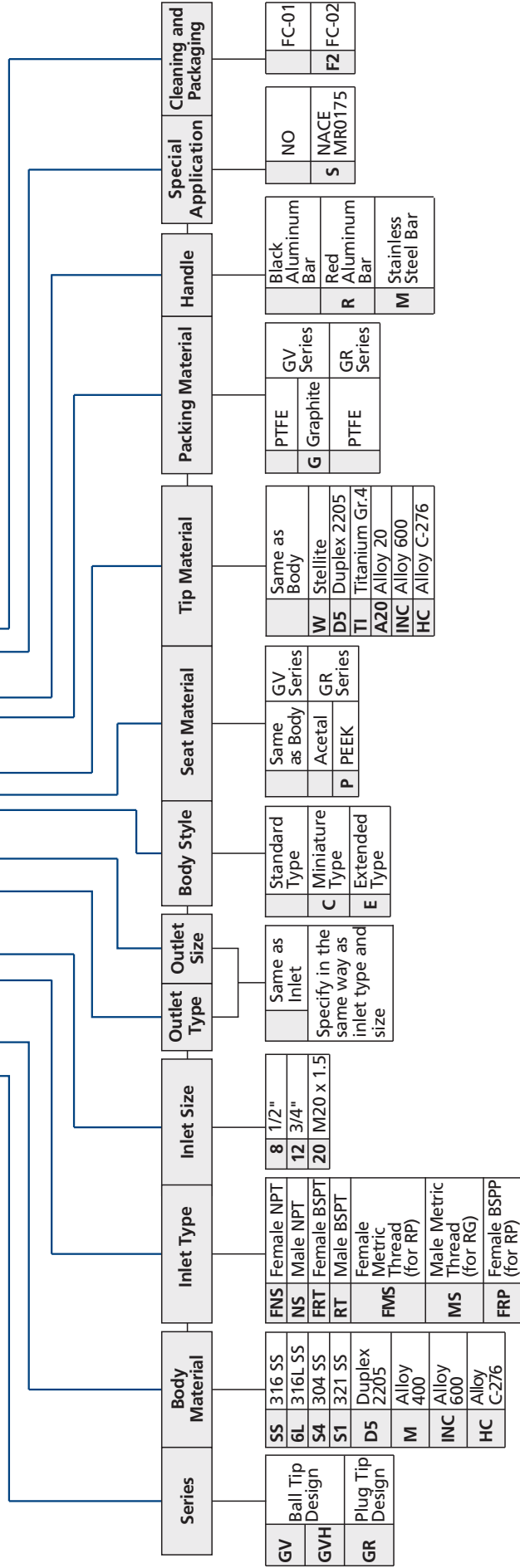

Note: "Ordering Number Description" is a reference to understand the combination rules of FITOK product part number. Not all combinations are available.

Cleaning and Packaging:

FC-01: Standard cleaning and packaging for general industrial procedures.

FC-02: Special cleaning and packaging for wetted system components to ensure compliance with product cleanliness requirement as stated in ASTM G93 Level C.

Instrumentation Manifolds

Features

- ⦿ Working pressure up to:
 - Stainless steel: 2D, 2R, 3D, 3R, 5D, 5R up to 6000 psig (414 bar)
 - 2DH, 2RH, 3DH, 3RH, 5DH, 5RH up to 10000 psig (690 bar)
 - Alloy C-276: 2D, 2R, 3D, 3R, 5D, 5R up to 6000 psig (414 bar)
- ⦿ Working temperature:
 - PTFE packing: -65°F to 450°F (-54°C to 232°C)
 - Graphite packing: -65°F to 1200°F (-54°C to 649°C)
- ⦿ Orifice: 0.157" (4.0 mm)
- ⦿ Two-piece stem design: Upper stem threads cold rolled and hardened lower stem for high strength and smooth operation
- ⦿ Upper stem thread lubricant isolated from system media
- ⦿ Linear instead of rotary motion of the rising, non-rotating stem minimizes packing abrasion and reduces the friction between the seat and the tip
- ⦿ Safety back seating seals in fully open position
- ⦿ Steady and durable fastening of the handle by double lock-pins
- ⦿ Each 2D/2R/3D/3R/5D/5R Series manifold leak tested with Nitrogen or compressed air at the maximum working pressure, each 2DH/2RH/3DH/3RH/5DH/5RH Series manifold leak tested with water at 1.1 times the maximum working pressure



Pressure vs. Temperature

2D, 2R, 3D, 3R, 5D, 5R Series

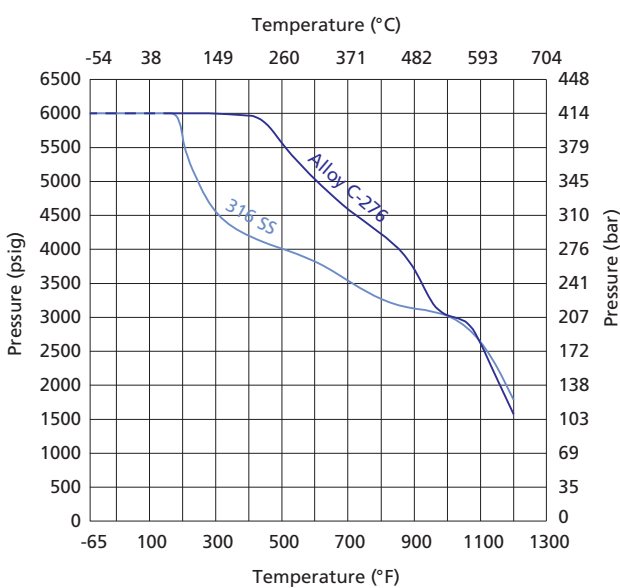

2DH, 2RH, 3DH, 3RH, 5DH, 5RH Series

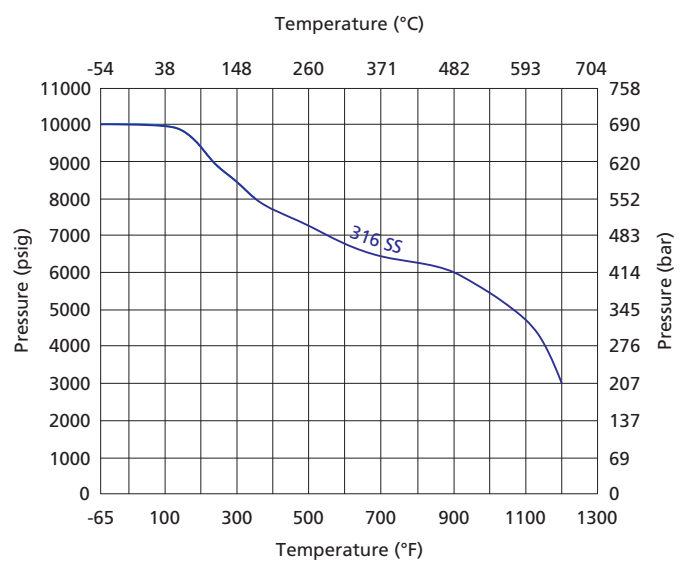

1. Based on graphite packing.
 2. Contact FITOK Group or our authorized distributors for curve graph of other materials.

Standard Materials of Construction

Item	Component	Valve Body Material	
		316 SS	Alloy C-276
Material Grade/ASTM Specification			
1	Handle	6061/B211	
2	Set Screw	Stainless steel	
3	Packing Bolt	304 SS/A479	
4	Upper Stem	316 SS/A479	
5	Lock Nut	Stainless steel	
6	Bonnet	316 SS/A479	Alloy C-276/B574
7	Gland	316 SS/A479	
8	Packing	PTFE or Graphite	
9	Lock Pin	Stainless steel	
10	Lower Stem	Hardened 316 SS/A479	Alloy C-276/B574
11	Body	316 SS/A479 316 SS/A182	Alloy C-276/B564
Lubricant		Molybdenum disulfide-based	

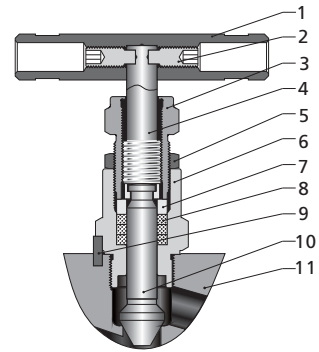

Handle colors indicate function:
 BLACK=Isolate/block
 RED=Test/vent
 GREEN=Equalize

Process interface valves for sour gas service are available. Materials are selected in accordance with NACE MR0175/ISO 15156. Contact FITOK Group or our authorized distributors if you have any request.

Design Standards

- Instrumentation manifolds are designed and manufactured in accordance with ASME B31.3 and MSS-SP-105. Flanges in compliance with MSS SP-99 or IEC 61518 are available.
- 2-valve manifold is used with pressure gauges or pressure transmitters.
- 3-valve and 5-valve manifolds are used with differential pressure transmitters.

Types and Dimensions

2-valve Manifolds

Consist of one block valve and one bleed valve

Basic Ordering Number	Inlet/Process	Outlet/Instrument	Test/Vent
2D□□-FNS8-A	1/2 Female NPT	Flange	1/4 Female NPT
2DH□□-FNS8-A			

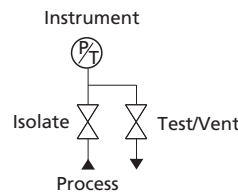
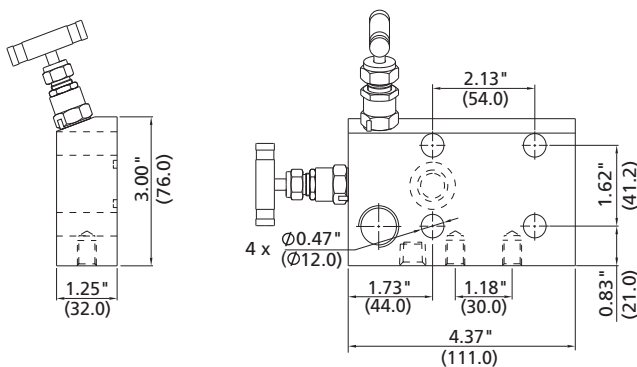

Notes: 1. Every manifold is supplied with one PTFE sealing ring for manifold-to-instrument and four 7/16" UNF x 1.75" high tensile bolts

2. Dimensions shown are for 2D Series manifolds. For dimensions of 2DH Series manifolds, please contact FITOK Group or our authorized distributors

C-10 Gauge Valves and Instrumentation Manifolds

Basic Ordering Number	Inlet/Process	Outlet/Instrument	Test/Vent
2D□□-FNS8-L	1/2 Female NPT	Flange	1/4 Female NPT

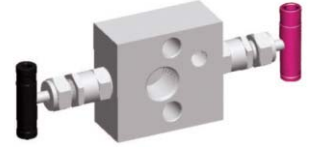
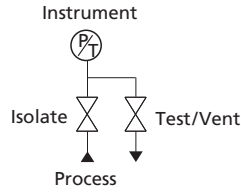
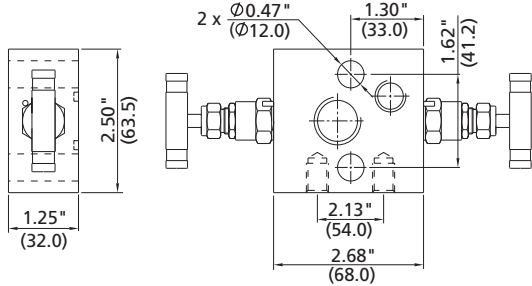

Every manifold is supplied with one PTFE sealing ring for manifold-to-instrument and two 7/16" UNF x 1.75" high tensile bolts.

Basic Ordering Number	Inlet/Process	Outlet/Instrument	Test/Vent
2D□□-FNS8-V	1/2 Female NPT	Flange	1/4 Female NPT

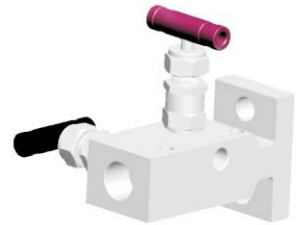
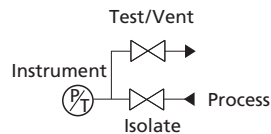
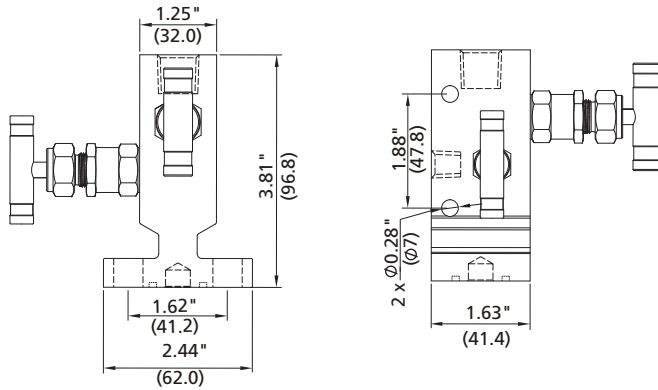

Every manifold is supplied with one PTFE sealing ring for manifold-to-instrument and two 7/16" UNF x 24 mm high tensile bolts.

Basic Ordering Number	Inlet/Process	Outlet/Instrument	Test/Vent
2R□□-FNS4-A	1/4 Female NPT	1/4 Female NPT	1/4 Female NPT
2RH□□-FNS4-A			

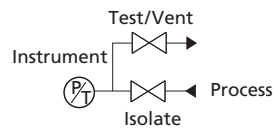
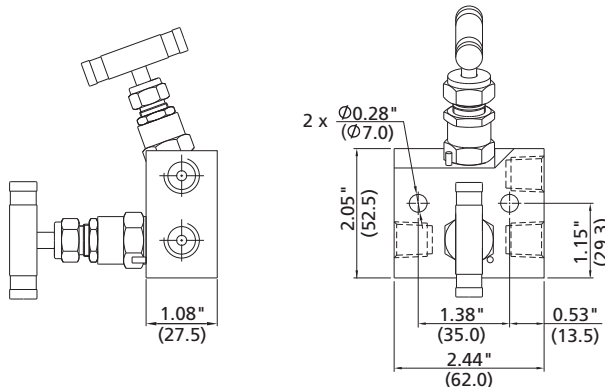

Dimensions shown are for 2R Series manifolds. For dimensions of 2RH Series manifolds, please contact FITOK Group or our authorized distributors.

Basic Ordering Number	Inlet/Process	Outlet/Instrument	Test/Vent
2R □□ -FNS8-L	1/2 Female NPT	1/2 Female NPT	1/4 Female NPT

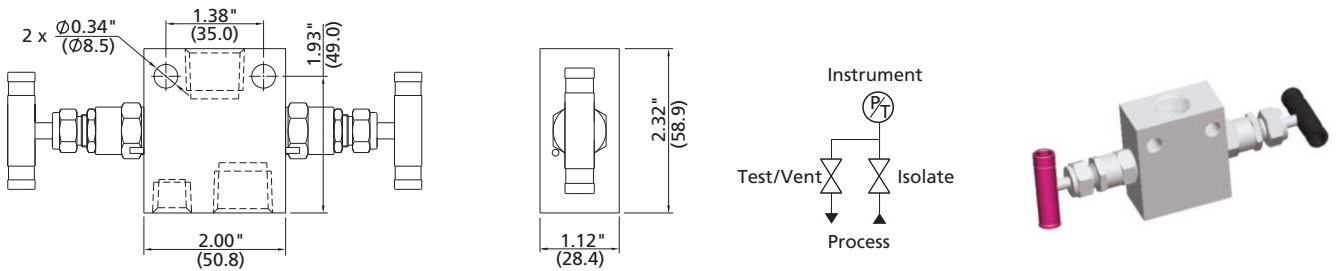

Basic Ordering Number	Inlet/Process	Outlet/Instrument	Test/Vent
2R □□ -FNS8-NS8-H	1/2 Female NPT	1/2 Male NPT	1/4 Female NPT
2RH □□ -FNS8-NS8-H			
2R □□ -NS8-H	1/2 Male NPT	1/2 Male NPT	1/4 Female NPT
2RH □□ -NS8-H			

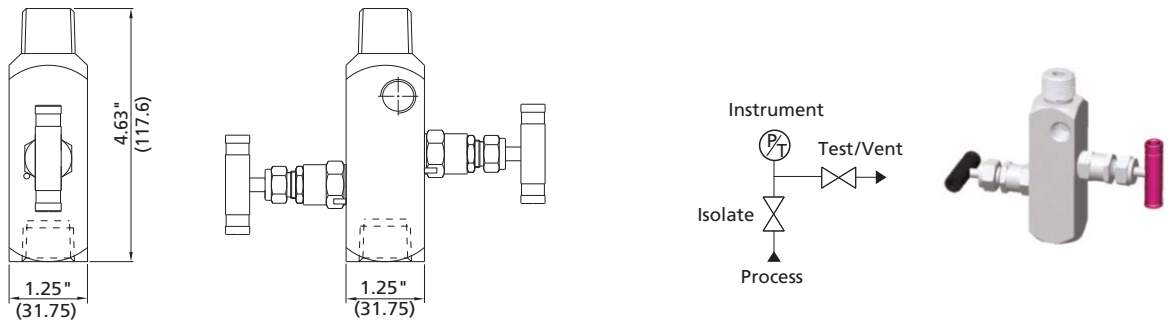

Dimensions shown are for 2R Series manifolds. For dimensions of 2RH Series manifolds, please contact FITOK Group or our authorized distributors.

Basic Ordering Number	Inlet/Process	Outlet/Instrument	Test/Vent
2R □□ -FNS8-V	1/2 Female NPT	1/2 Female NPT	1/4 Female NPT

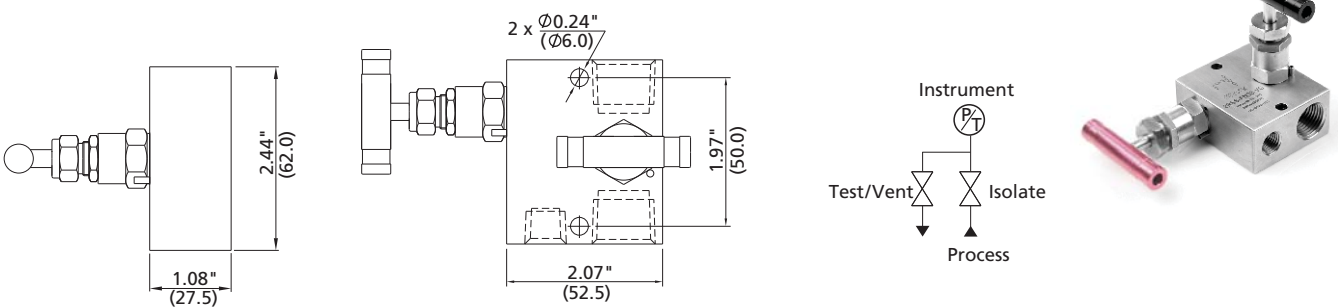

C-12 Gauge Valves and Instrumentation Manifolds

3-valve Manifolds

Consist of two block valves and one equalizer valve

Basic Ordering Number	Inlet/Process	Outlet/Instrument
3D □□ -FNS8-A	1/2 Female NPT	Flange
3DH □□ -FNS8-A		
3D □□ -FL8-A	1/2" FITOK	Flange

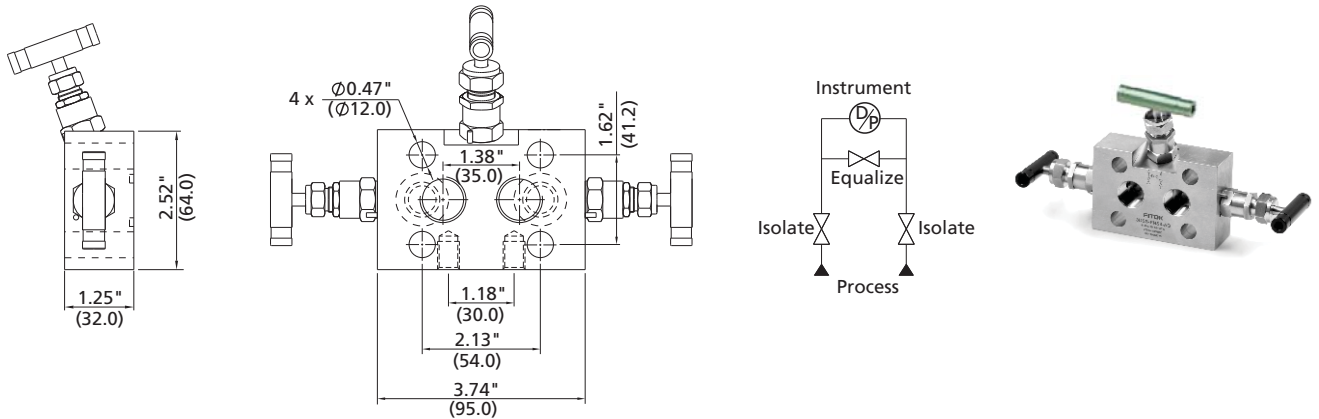

- Notes: 1. Every manifold is supplied with two PTFE sealing rings manifold-to-instrument and four 7/16" UNF x 1.75" high tensile bolts.
 2. FL8 connections are obtained by adding an extra CM tube fitting to the FNS8 connections.
 3. Dimensions shown are for 3D Series manifolds. For dimensions of 3DH Series manifolds, please contact FITOK Group or our authorized distributors.

Basic Ordering Number	Inlet/Process	Outlet/Instrument	Test/Vent
3D □□ -FNS8-L	1/2 Female NPT	Flange	Optional
3D □□ -FL8-L	1/2" FITOK	Flange	Optional

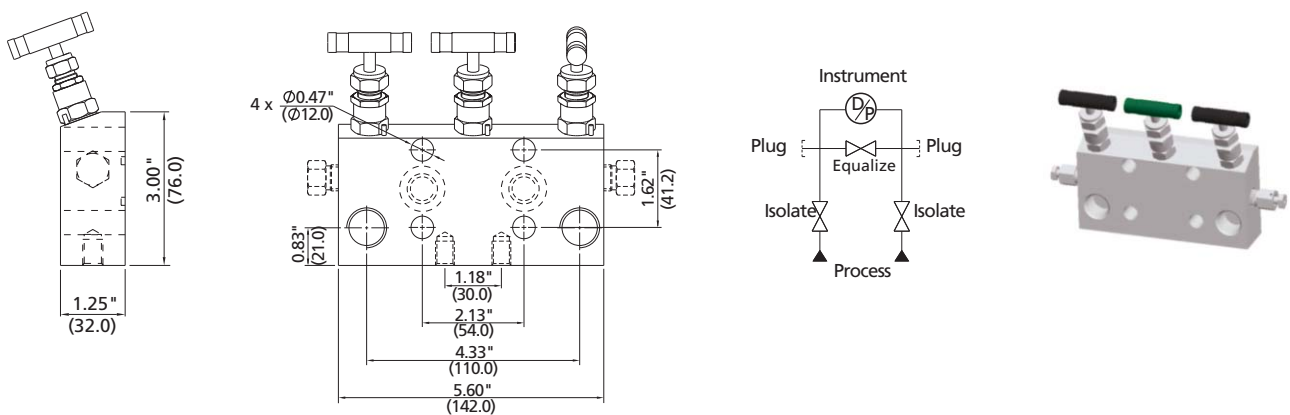

- Notes: 1. Every manifold is supplied with two PTFE sealing rings for manifold-to-instrument and four 7/16" UNF x 1.75" high tensile bolts.
 2. FL8 connections are obtained by adding an extra CM tube fitting to the FNS8 connections.

Basic Ordering Number	Inlet/Process	Outlet/Instrument	Test
3D□□-FNS8-V	1/2 Female NPT	Flange	Optional

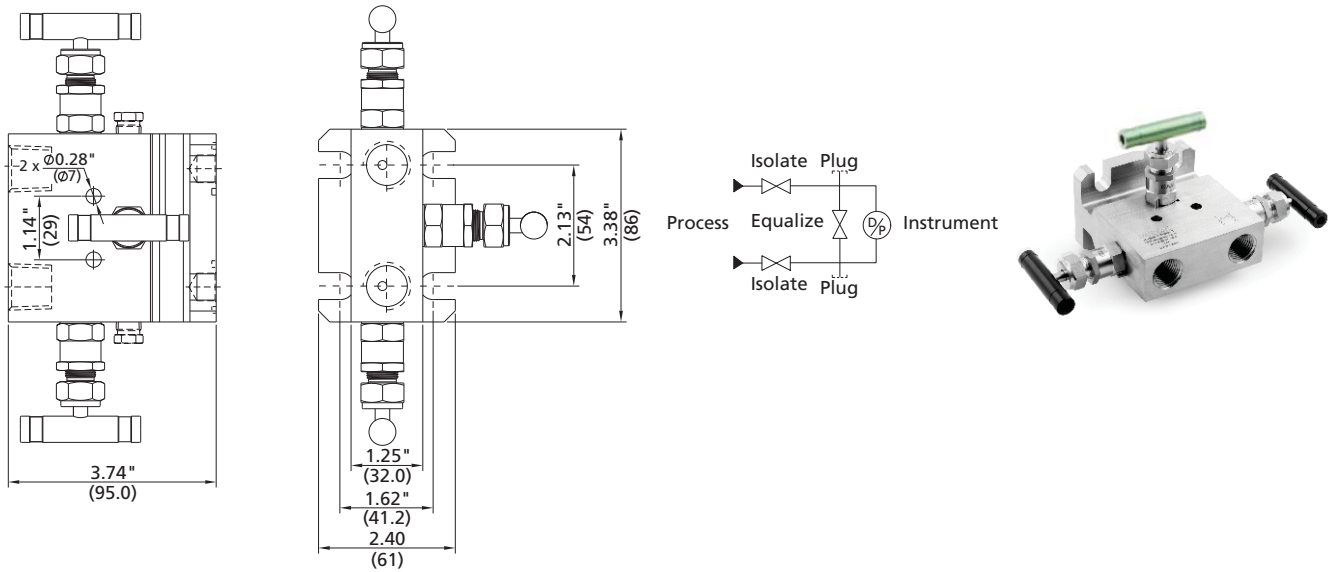

Every manifold is supplied with two PTFE sealing ring for manifold-to-instrument and four 7/16" UNF x 24 mm high tensile bolts.

Basic Ordering Number	Inlet/Process	Outlet/Instrument	Test
3D□□-F-V	Flange	Flange	Optional

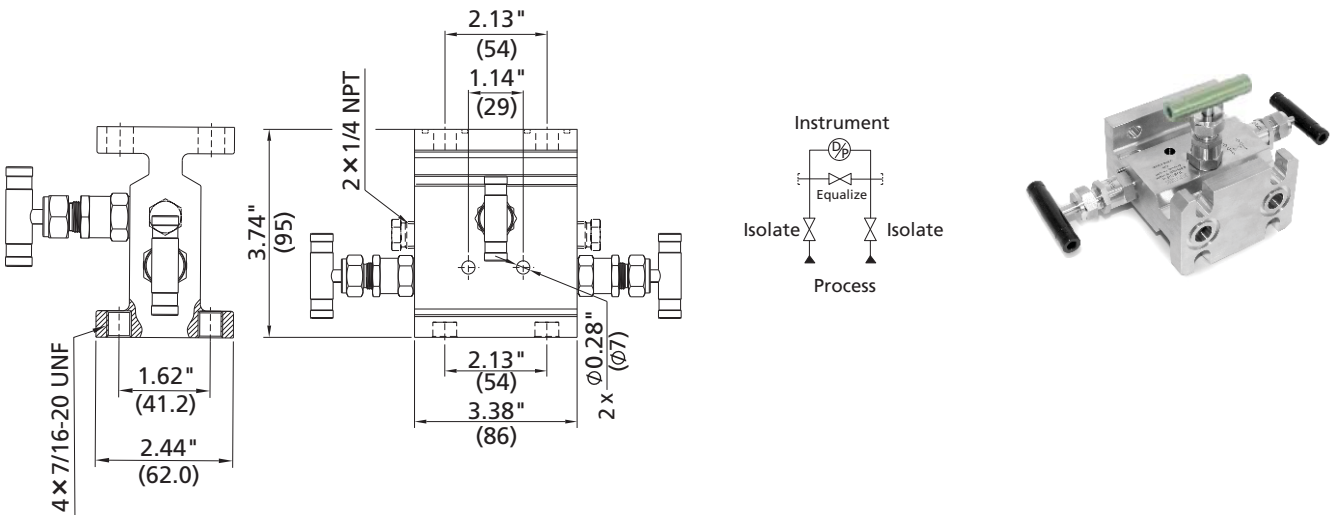

Every manifold is supplied with two PTFE sealing ring for manifold-to-instrument and four 7/16" UNF x 24 mm high tensile bolts.

Manifolds

C-14 Gauge Valves and Instrumentation Manifolds

Basic Ordering Number	Inlet/Process	Outlet/Instrument	Test
3R □□ -FNS8-V	1/2 Female NPT	1/2 Female NPT	Optional
3RH □□ -FNS8-V			
3R □□ -FL8-V	1/2" FITOK	1/2" FITOK	Optional

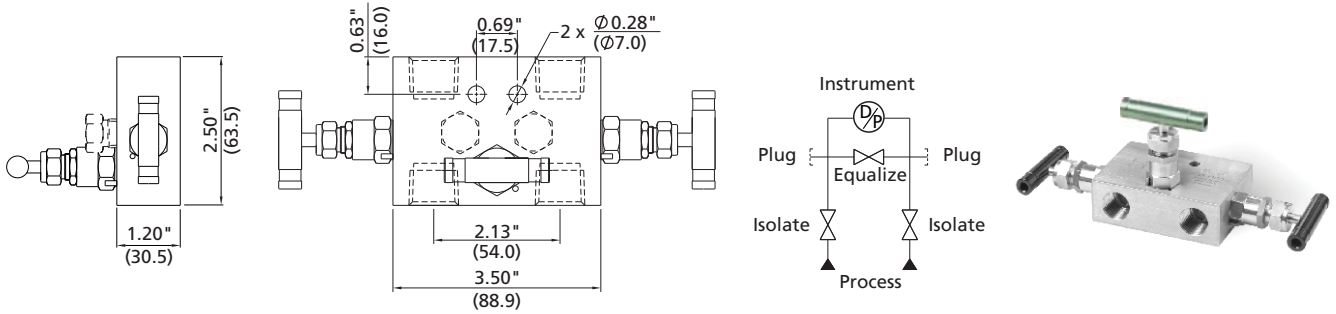

Notes: 1. FL8 connections are obtained by adding an extra CM tube fitting to the FNS8 connections.

2. Dimensions shown are for 3D Series manifolds. For dimensions of 3DH Series manifolds, please contact FITOK Group or our authorized distributors.

5-valve Manifolds

1. 5-valve Manifold of Double-bleed Function:

consist of two block valves, two bleed valves and one equalizer valve

Basic Ordering Number	Inlet/Process	Outlet/Instrument	Test
5D □□ -FNS8-A	1/2 Female NPT	Flange	1/4 Female NPT
5DH □□ -FNS8-A			
5D □□ -FL8-A	1/2" FITOK	Flange	1/4 Female NPT

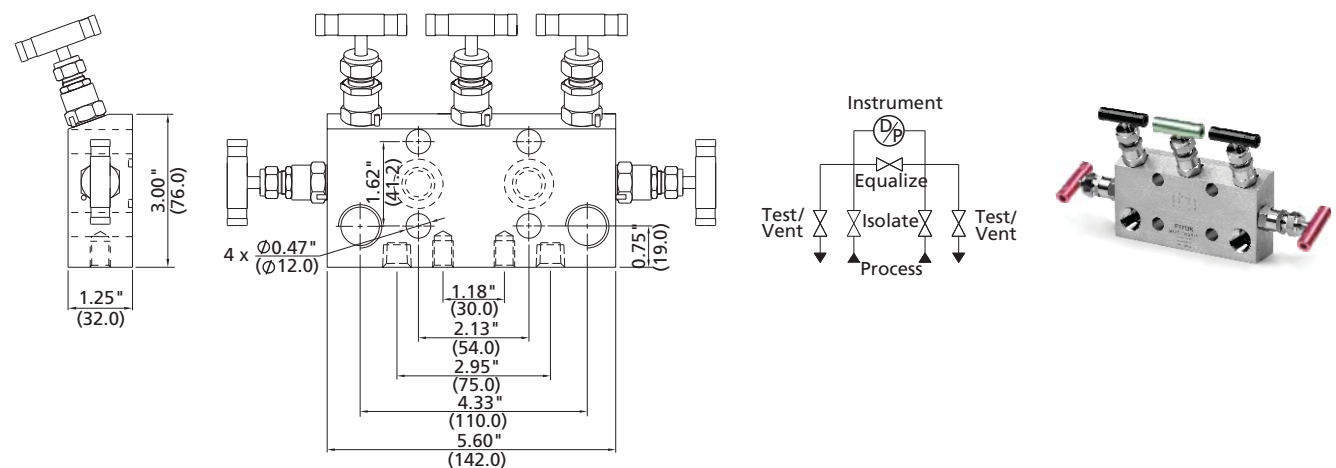

Notes: 1. Every manifold is supplied with two PTFE sealing rings for manifold-to-instrument and four 7/16" UNF x 1.75" high tensile bolts.

2. FL8 connections are obtained by adding an extra CM tube fitting to the FNS8 connections.

3. Dimensions shown are for 5D Series manifolds. For dimensions of 5DH Series manifolds, please contact FITOK Group or our authorized distributors.

Basic Ordering Number	Inlet/Process	Outlet/Instrument	Test/Vent
5D□□-FNS8-V	1/2 Female NPT	Flange	1/4 Female NPT

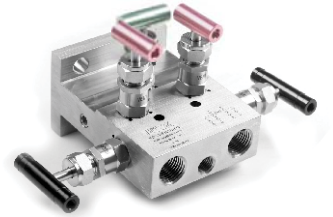
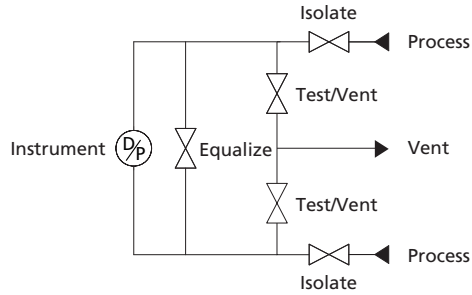
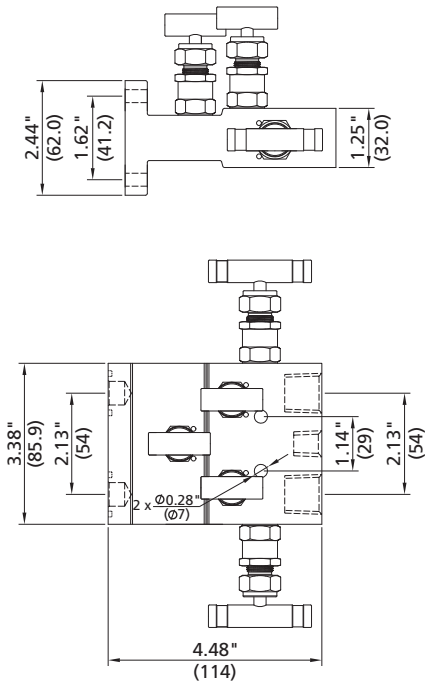

Every manifold is supplied with two PTFE sealing ring for manifold-to-instrument and four 7/16" UNF x 24 mm high tensile bolts.

Basic Ordering Number	Inlet/Process	Outlet/Instrument	Test/Vent
5R□□-FNS8-L	1/2 Female NPT	1/2 Female NPT	1/4 Female NPT
5RH□□-FNS8-L			
5R□□-FL8-FNS8-L	1/2" FITOK	1/2 Female NPT	1/4 Female NPT

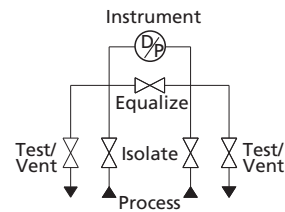
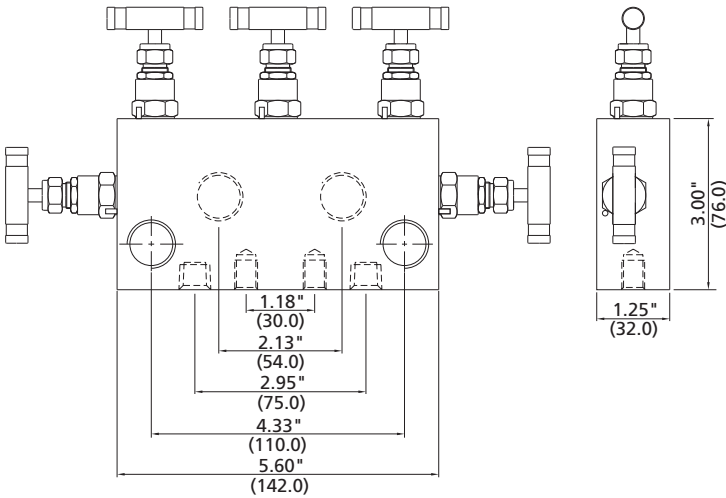

- Notes: 1. FL8 connections are obtained by adding an extra CM tube fitting to the FNS8 connections.
- 2. Dimensions shown are for 5R Series manifolds. For dimensions of 5RH Series manifolds, please contact FITOK Group or our authorized distributor.

Manifolds

C-16 Gauge Valves and Instrumentation Manifolds

Basic Ordering Number	Inlet/Process	Outlet/Instrument	Test/Vent
5R□□-FNS8-V	1/2 Female NPT	1/2 Female NPT	1/4 Female NPT

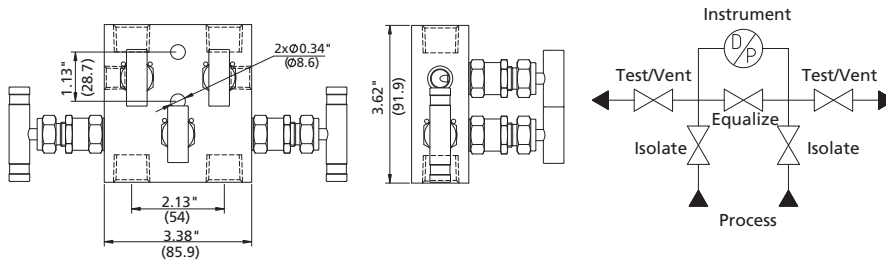

2. 5-valve Custody Transfer/Fiscal Metering Manifold (double-equalizer): consist of two block valves, one bleed valve and two equalizer valves

Basic Ordering Number	Inlet/Process	Outlet/Instrument	Vent	Test
5D□□-FNS8-AB	1/2 Female NPT	Flange	1/4 Female NPT	Optional
5D□□-FL8-AB	1/2" FITOK	Flange	1/4 Female NPT	Optional

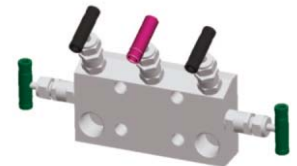
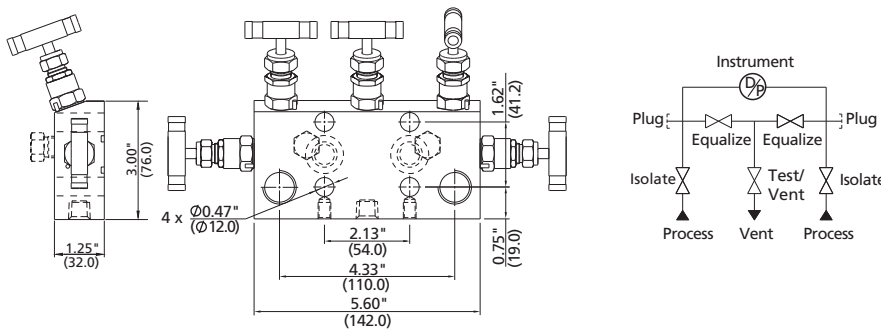

Notes: 1. Every manifold is supplied with two PTFE sealing rings for manifold-to-instrument and four 7/16" UNF x 1.75" high tensile bolts.
2. FL8 connections are obtained by adding an extra CM tube fitting to the FNS8 connections.

Basic Ordering Number	Inlet/Process	Outlet/Instrument	Vent	Test
5D□□-FNS8-VB	1/2 Female NPT	Flange	1/4 Female NPT	Optional

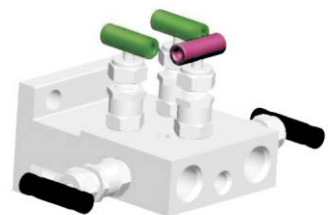
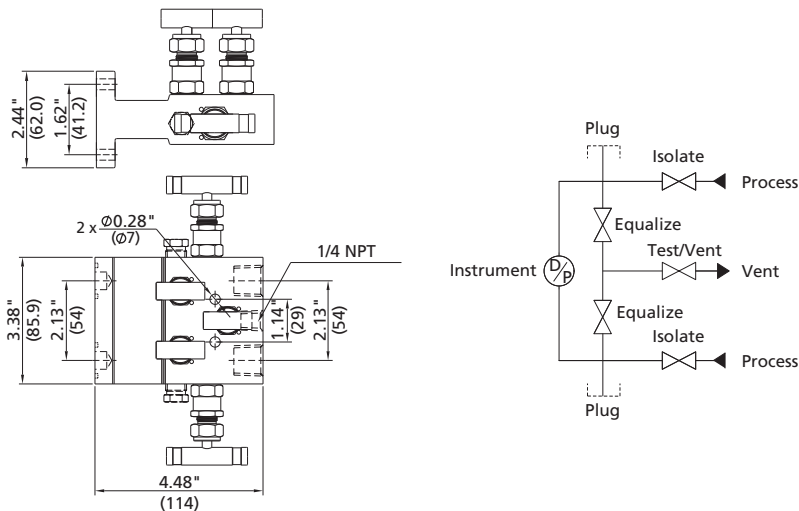

Every manifold is supplied with two PTFE sealing ring for manifold-to-instrument and four 7/16" UNF x 24 mm high tensile bolts.

Basic Ordering Number	Inlet/Process	Outlet/Instrument	Vent	Test
5D□□-F-VB	Flange	Flange	1/4 Female NPT	Optional

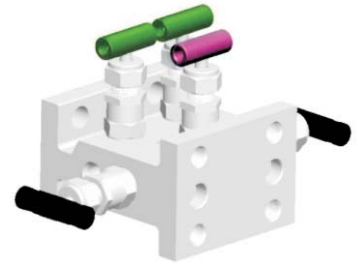
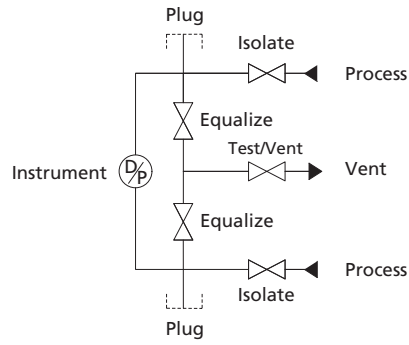
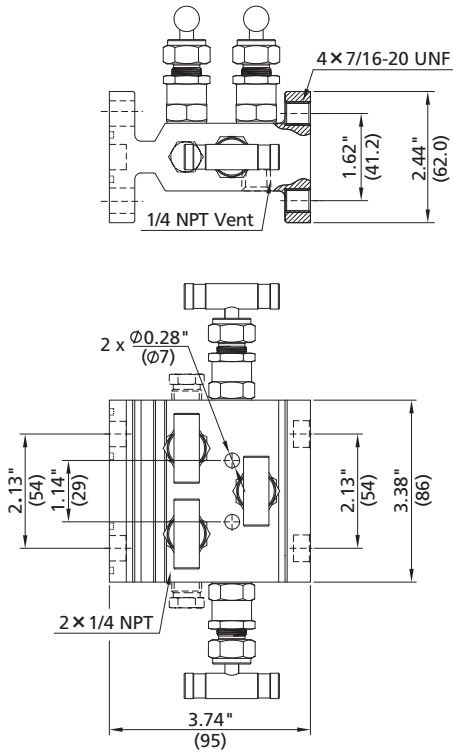

Every manifold is supplied with two PTFE sealing ring for manifold-to-instrument and four 7/16" UNF x 24 mm high tensile bolts.

Basic Ordering Number	Inlet/Process	Outlet/Instrument	Test/Vent
5R□□-FNS8-VB	1/2 Female NPT	1/2 Female NPT	1/4 Female NPT

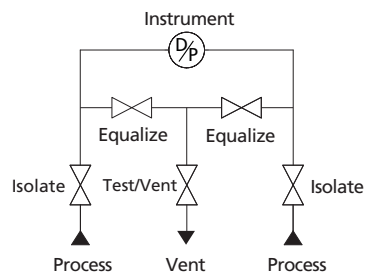
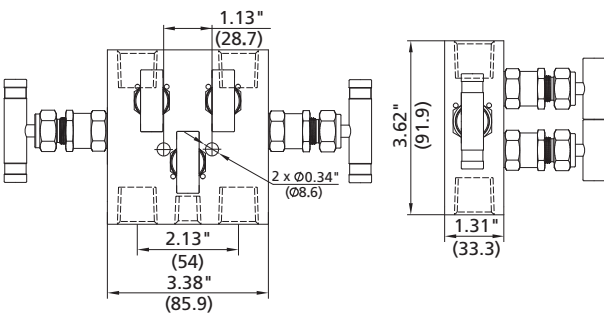

Manifolds

C-18 Gauge Valves and Instrumentation Manifolds

Basic Ordering Number	Inlet/Process	Outlet/Instrument	Vent	Test
5R□□-FNS8-AB	1/2 Female NPT	1/2 Female NPT	1/4 Female NPT	Optional
5R□□-FL8-FNS8-AB	1/2" FITOK	1/2 Female NPT	1/4 Female NPT	Optional

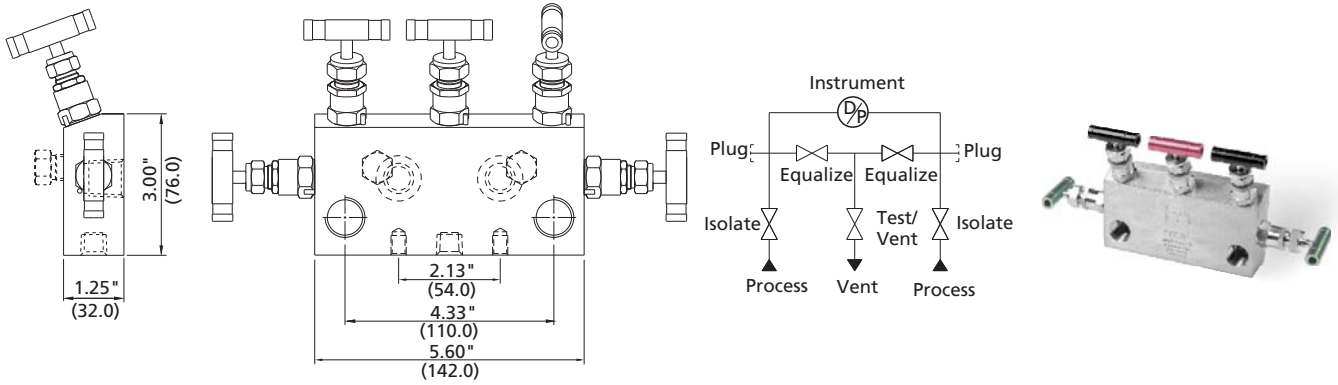

FL8 connections are obtained by adding an extra CM tube fitting to the FNS8 connections.

C Integral Manifolds

C Integral Manifold is specifically designed for the pressure transmitters of Rosemount® coplanar™, including Model 3051C, 3051S, 2024 and 3095. It can be assembled directly to transmitters, eliminating the need for flanges. Each of the following manifolds contains four 7/16" UNF x 2" high tensile bolts.

Basic Ordering Number	Inlet/Process	Outlet/Instrument	Test/Vent
2D□□-FNS8-C	1/2 Female NPT	Flange	1/4 Female NPT
2DH□□-FNS8-C			

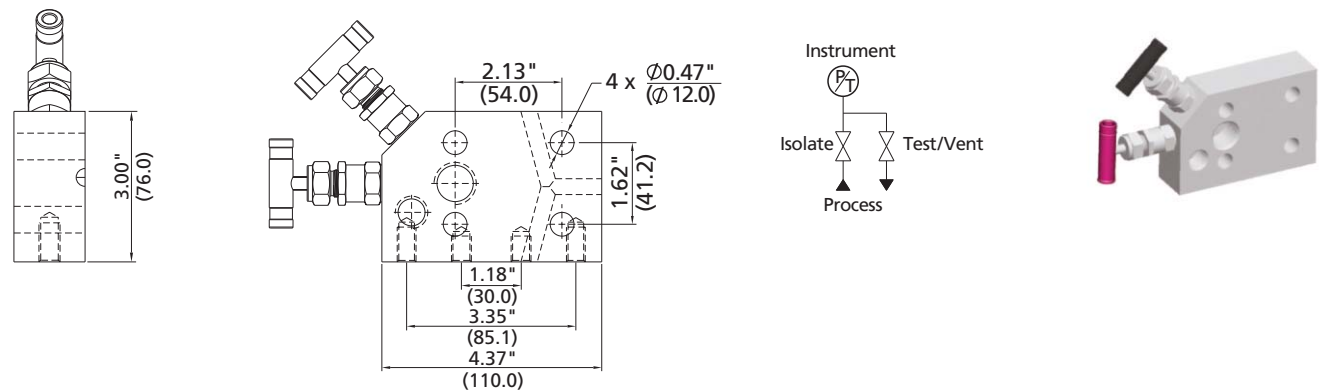

Basic Ordering Number	Inlet/Process	Outlet/Instrument	Test/Vent
3D □□ -FNS8-C	1/2 Female NPT	Flange	Optional
3DH □□ -FNS8-C			
3D □□ -FL8-C	1/2" FITOK	Flange	Optional

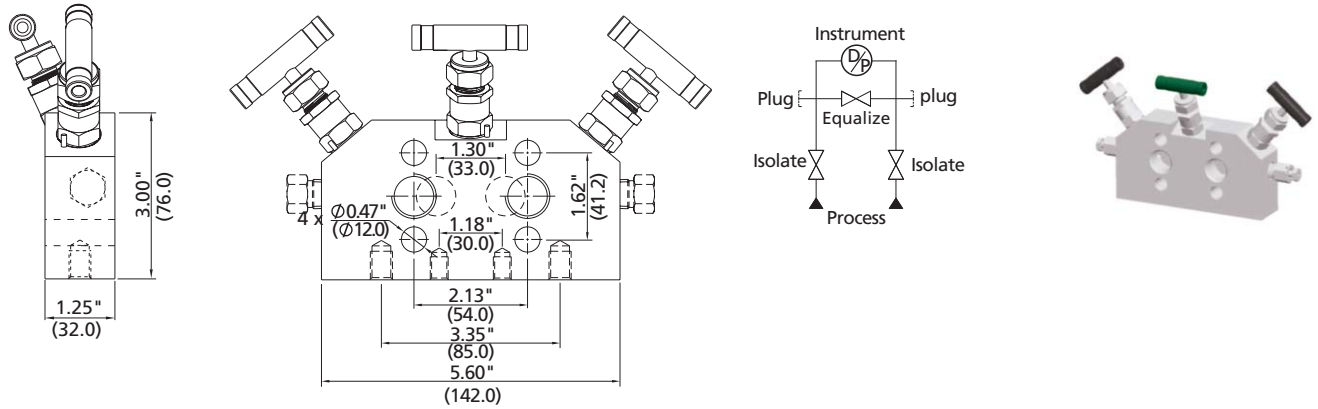

Basic Ordering Number	Inlet/Process	Outlet/Instrument	Test/Vent
5D □□ -FNS8-C	1/2 Female NPT	Flange	1/4 Female NPT
5DH □□ -FNS8-C			
5D □□ -FL8-C	1/2" FITOK	Flange	1/4 Female NPT

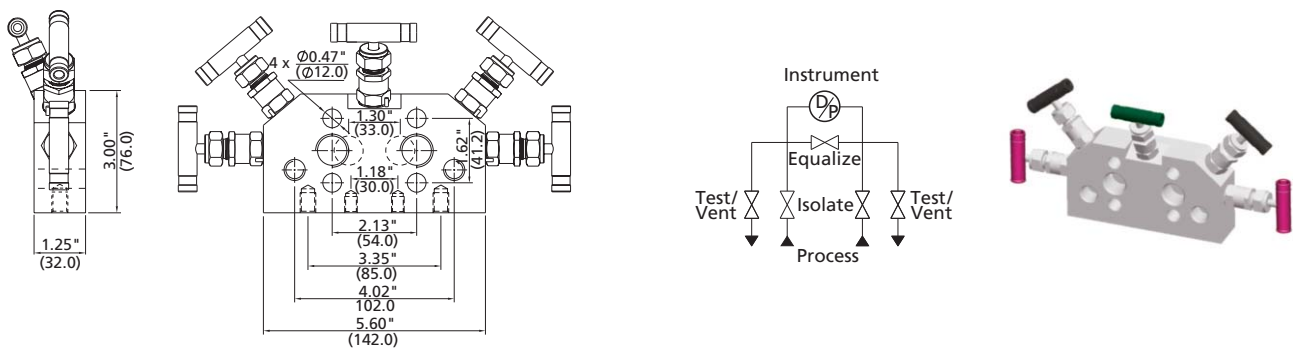

Dimensions shown are for 2D/3D/5D Series manifolds. For dimensions of 2DH/3DH/5DH Series manifolds, please contact FITOK Group or our authorized distributors.
 FL8 connections are obtained by adding an extra CM tube fitting to the FNS8 connections.

Manifolds

Ordering Number Description

3DSS - FNS8 - LG - ET - 1M - SF2

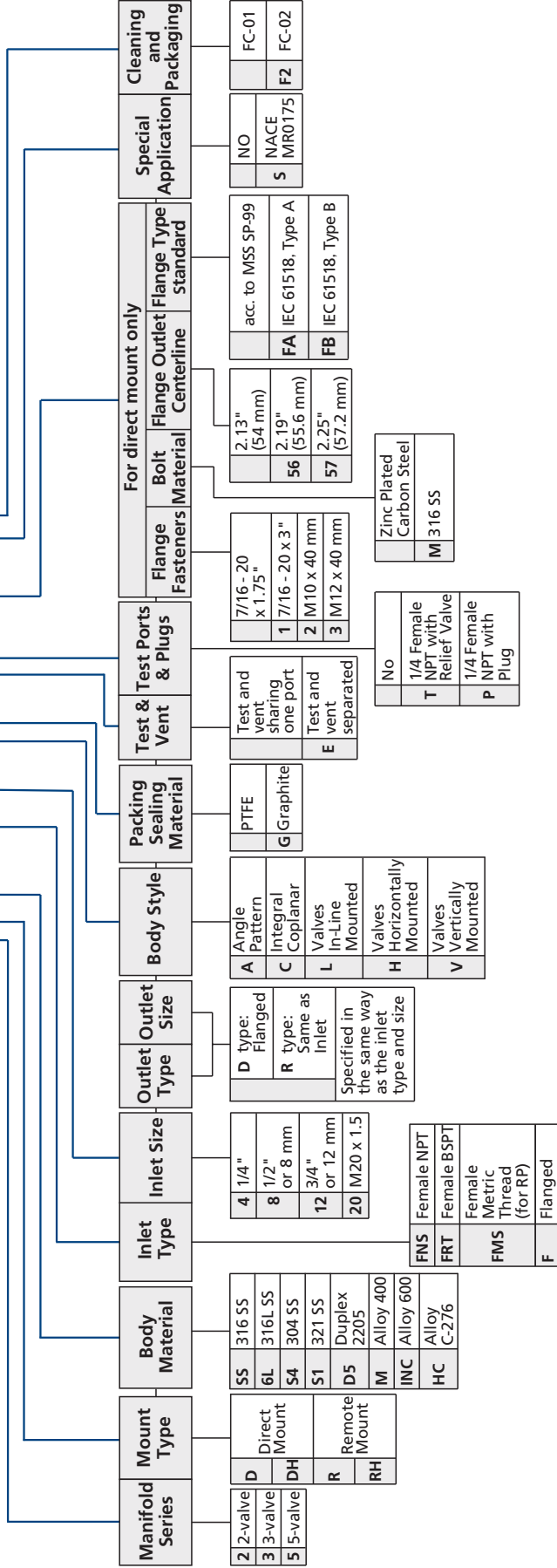

Notes:

- To order 5-valve manifolds with double-equalize function, add B to the Body Style of the manifold ordering number. Example: 5DSS-FNS8-AB
- Plug options are as follow:
 - 1) if option of test and vent sharing one port with plug is needed, add "-P" to the ordering number. Example: 5DSS - FNS8 - AB - P;
 - 2) If option of test and vent separating with a plug to the test port is needed, add "-EP" to the ordering number. Example: 5DSS - FNS8 - AB - EP;
 - 3) If option of test and vent separating with plug for each port is needed, add "-E2P" to the ordering number. Example: 5DSS - FNS8 - AB - E2P.
- The standard center line distance of direct mounting flange outlet of 3-valve manifold and 5-valve manifold is 2.13" (54 mm).
 Center line distance of 2.188" (55.6 mm) is suitable for range 6 and 7, 1151 series transmitter.
 Center line distance of 2.250" (57.2 mm) is suitable for range 8, 1151 series transmitter.
- The standard configuration of direct mounting manifold contains PTFE flange seal ring and 7/16-20 UNF X 1.75" high tensile bolts, can be connected with transmitters under main brands, such as EJA, Honeywell, Foxboro 843 dlp, and Rosemount® 151, 2024, 3051H series.
- 7/16-20 UNF x 3" high tensile bolts can be supplied, can be used for coplanar mounting of the Rosemount® 3051C transmitter with process flange and the manifold.
- Cleaning and Packaging:
 FC-01: Standard cleaning and packaging for general industrial procedures.
 FC-02: Special cleaning and packaging for wetted system components to ensure compliance with product cleanliness requirement as stated in ASTM G93 Level C.
- "Ordering Number Description" is a reference to understand the combination rules of FITOK product part number. Not all combinations are available.

Accessories

Manifold Bracket Supports

SS-M2P-2BK

1. The integral assembly includes: bracket, U-bolts, bolts, gaskets, nuts
2. Fits with 2R□□-XX-A, 2R□□-XX-L, 2RH□□-XX-A

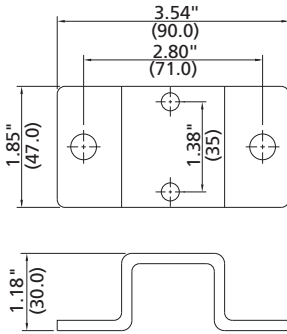

3. SS-M2P-2BK-50 fits with 2R□□-XX-V
4. SS-M2P-2BK-17.5 fits with 3R□□-XX-V
5. SS-M2P-2BK-28.7 fits with 5R□□-XX-VB, 5R□□-XX-V

SS-M2P-6BK

1. The integral assembly includes: bracket, U-bolts, bolts, gaskets, nuts
2. Fits with 2D□□-XX-C, 3D□□-XX-C, 5D□□-XX-C, 2DH□□-XX-C, 3DH□□-XX-C, 5DH□□-XX-C

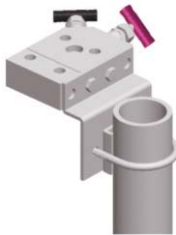
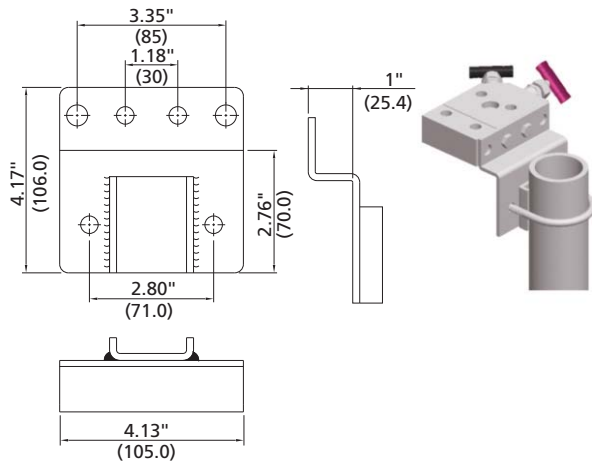

SS-M2P-4BK

1. The bracket support is available for horizontal or vertical installation
2. The integral assembly includes: bracket, U-bolts, bolts, gaskets, nuts
3. Fits with 2D□□-XX-A, 2D□□-XX-L, 3D□□-XX-A, 3D□□-XX-L, 5D□□-XX-A, 5D□□-XX-AB, 5R□□-XX-L, 5R□□-XX-AB, 2DH□□-XX-A, 3DH□□-XX-A, 5DH□□-XX-A, 5RH□□-XX-AB

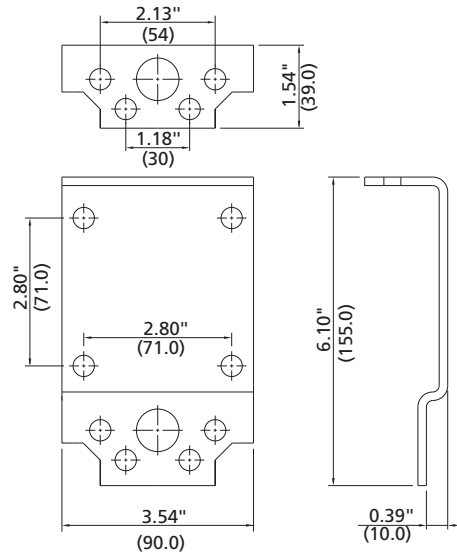

SS-M2P-8BK

1. The bracket support is available for horizontal or vertical installation
2. The integral assembly includes: bracket, U-bolts, bolts, gaskets, nuts
3. Fits with 2D□□-XX-A, 3D□□-XX-A, 3D□□-XX-L, 2D□□-XX-C, 3D□□-XX-C, 5D□□-XX-C

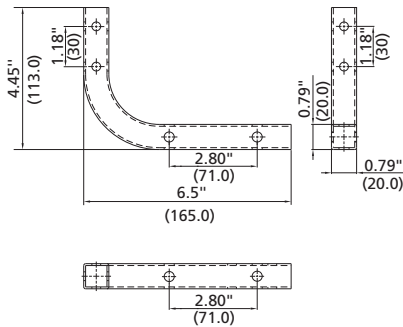

For more installation information regarding other manifolds, please contact FITOK Group or our authorized distributors.

Kidney Flanges and Eccentric Flanges

Features

- Working temperature:
 - PTFE: -65°F to 450°F (-54°C to 232°C)
 - Graphite: -65°F to 1200°F (-54°C to 649°C)
- Integral forged body
- Standard material: A182 F316

Types and Dimensions

Kidney Flanges

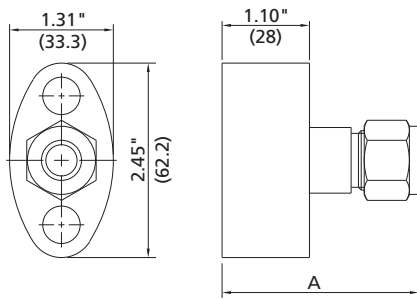

Eccentric Flanges

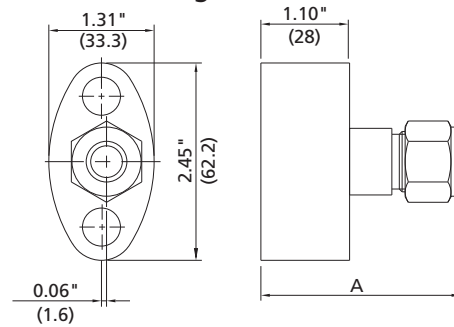

The process connection type of transmitter can be transformed to other connection types.

Ordering Information

Basic Ordering Number	Connection Type and Size	Dimension in. (mm)
		A
SS-KF-FNS4	1/4 Female NPT	1.10 (28)
SS-KF-FNS8	1/2 Female NPT	1.10 (28)
SS-KF-FL8	1/2" FITOK	2.48 (63)
SS-KF-PB8	1/2 PB	2.10 (53.3)

A kidney flange set contains a PTFE flange seal ring and two 7/16 - 20 UNF high tensile bolts.

Ordering Information

Basic Ordering Number	Connection Type and Size	Dimension in. (mm)
		A
SS-EF-FNS4	1/4 Female NPT	1.10 (28)
SS-EF-FNS8	1/2 Female NPT	1.10 (28)
SS-EF-FL8	1/2" FITOK	2.48 (63)
SS-EF-PB8	1/2 PB	2.10 (53.3)

1. Eccentric flange needs to be ordered in whole set.
2. A whole eccentric flange set contains two eccentric flanges, two PTFE flange seal rings and four 7/16 - 20 UNF high tensile bolts.

The Selection of Flange Seal Materials

The standard flange seal material is PTFE, graphite is an option. To order graphite flange seal material, add "- G" as a suffix.

Various Combinations of Eccentric Flange Set

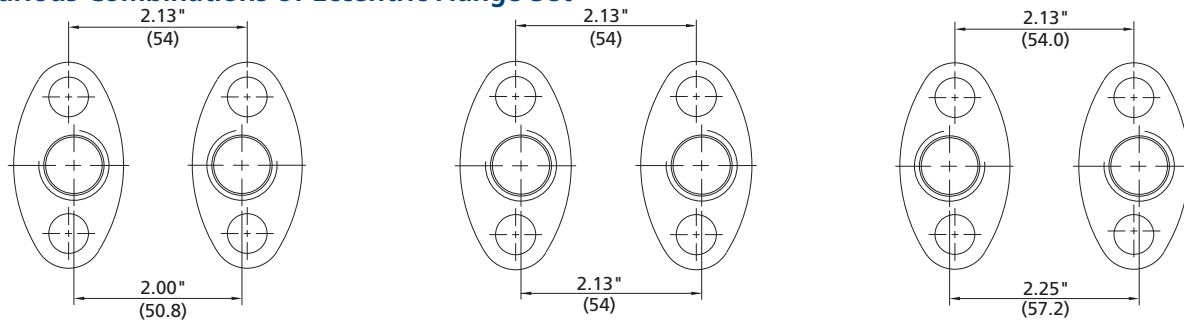

Combinations of eccentric flange set can give different center line distances of 2.0" (50.8 mm), 2.13" (54 mm) and 2.25" (57 mm).

Bleed Valves

- RB Series RBSS-NS4 Bleed Valve is used as standard test/vent valve.
- For more information, refer to FITOK Bleed Valve RB Series.

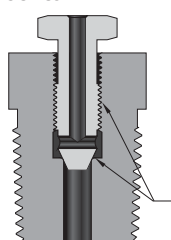

Chrome-plated Stem and Tip Extend Cycle Life.

Calibration Fittings

- The calibration fittings can be connected directly with the bleed port of transmitter so that the calibration process can be simplified.
- For more information, refer to FITOK Calibration Fittings.

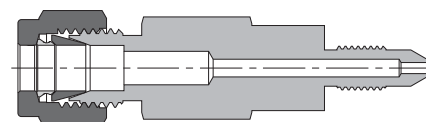

Block and Bleed Valves

BB, DB, SB and DBB Series



Contents

BB Series: Single Block and Bleed Valves	C-28
--	------

DB Series: Double Block Valves	C-34
--------------------------------	------

SB Series: Single Block Valves	C-35
--------------------------------	------

DBB Series: Double Block and Bleed Valves	C-36
---	------

Features

- ⦿ Pressure ratings in accordance with ASME B16.34
- ⦿ Color coded handles indicate functions
- ⦿ Every valve is factory tested in accordance with API 598 or EN 12266
- ⦿ Flange connections comply with ASME B16.5, EN 1092-1 compliance is also available upon request
- ⦿ Bleed port equipped with plug
- ⦿ Weight, space and cost saving over traditional design

Ball Valve Model

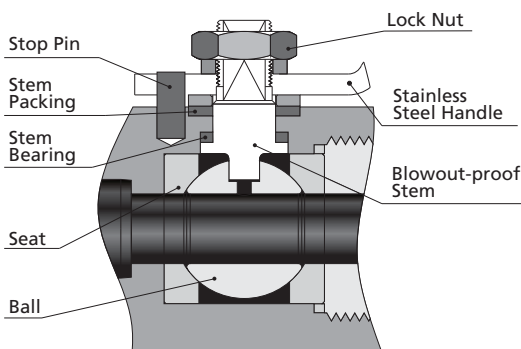

Features

- ⦿ Pressure rating up to: Class 2500
- ⦿ Working temperature : -65°F to 450°F (-54°C to 232°C)
- ⦿ Actuate at quarter-turn
- ⦿ Directional stem flats show open or closed position
- ⦿ Bottom-loaded stem prevents stem blowout and enhances system safety
- ⦿ High-strength stem bearing provides smooth actuation and eliminates galling between valve stem and body
- ⦿ It may be required to adjust the packing during the service life of the valve
- ⦿ FITOK ball valves are designed to be operated in a fully open or fully closed position

Needle Type Valve Model

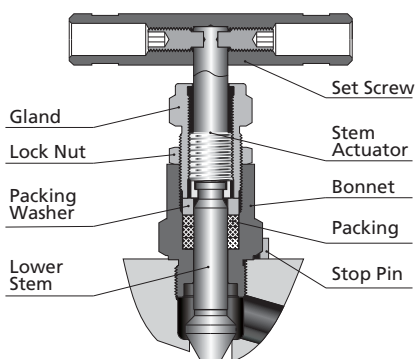

Features

- ⦿ Pressure rating up to: Class 4500
- ⦿ Working temperatures are as follows:
PTFE: -65°F to 450°F (-54°C to 232°C)
Graphite: -65°F to 1200°F (-54°C to 649°C)
- ⦿ Two-piece stem design: Upper stem threads cold rolled and hardened lower stem for high strength and smooth operation
- ⦿ Upper stem thread lubricant is isolated from system fluid
- ⦿ Linear instead of rotary motion of the rising, non-rotating stem minimizes packing abrasion and reduces the friction between the seat and the tip
- ⦿ Stem back seating seals in fully open position
- ⦿ Double lock-pins enable steady and durable fastening of the handle

OS&Y Needle Type Valve Model

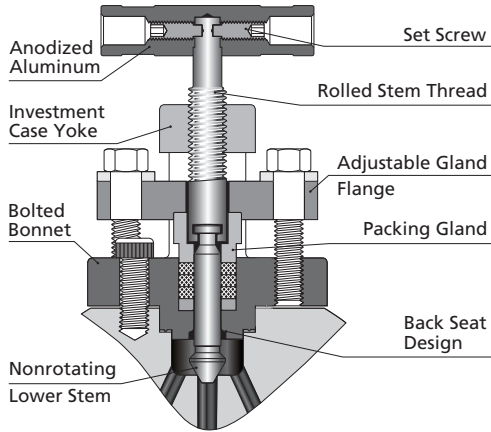

Features

- ⦿ Pressure rating up to: Class 2500
- ⦿ Working temperatures are as follows:
 - PTFE: -65°F to 450°F (-54°C to 232°C)
 - Graphite: -65°F to 1200°F (-54°C to 649°C)
- ⦿ Two-piece stem design: Upper stem threads cold rolled and hardened lower stem for high strength and smooth operation
- ⦿ Upper stem thread lubricant is isolated from system fluid
- ⦿ Linear instead of rotary motion of the rising, non-rotating stem minimizes packing abrasion and reduces the friction between the seat and the tip
- ⦿ Bolted bonnet enhances strength and reliability
- ⦿ Back seat design provides secondary stem sealing and prevents stem blowout
- ⦿ Adjustable gland flange allows easy access to the packing gland and packing adjustment for an effective stem seal
- ⦿ Investment case yoke is formed by precision casting which enhances strength and perfect stem alignment
- ⦿ Two handle pins make the handle fixed firmly and lastingly

Handle colors indicate functions:

Needle and OS&Y valves:

BLACK = Isolate/Block **RED** = Vent/Bleed

Ball valves:

YELLOW = Isolate/Block **RED** = Vent/Bleed

Standard Materials of Construction

Component	Body Material				
	Stainless Steel		Carbon Steel	Duplex Stainless Steel	
	Material Grade/Specification				
Body/End Connector	316 SS, 316L SS /A182	316 SS, 316L SS /A479	A105, LF2/A350	F51/A182	S31803/A479
Ball Valve	Ball	316 SS, 316L SS/A479			S31803/A479
	Stem				
	Washer				
	Stop Block	304 SS/A240			
	Seat	PEEK/PCTFE			
	Needle Type Globe Valve	Stem Tip	316 SS, 316L SS/A479		
Stem					
Bonnet					
OS&Y Needle Type Globe Valve	Stem Tip	316 SS, 316L SS/A479			S31803/A479
	Stem				
	Packing Gland				
	Yoke				

Stainless steel is standard material, others are available upon request.

Flange Connection

Pressure - Temperature Rating

FITOK Block and Bleed Valves offer a variety of sizes and pressure ratings of the flange in accordance with ASME B16.5 Specifications. Ratings are taken from ASME B16.5, Table 2-2.2 and Table F2-2.2. The rating data are based on stainless steel F316/A182.

Temp. °C	ASME Ratings					
	150	300	600	900	1500	2500
	Working Pressure, bar					
-29 to 38	19.0	49.6	99.3	148.9	248.2	413.7
50	18.4	48.1	96.2	144.3	240.6	400.9
100	16.2	42.2	84.4	126.6	211.0	351.6
150	14.8	38.5	77.0	115.5	192.5	320.8
200	13.7	35.7	71.3	107.0	178.3	297.2
250	12.1	33.4	66.8	100.1	166.9	278.1
300	10.2	31.6	63.2	94.9	158.1	263.5
325	9.3	30.9	61.8	92.7	154.4	257.4
350	8.4	30.3	60.7	91.0	151.6	252.7
375	7.4	29.9	59.8	89.6	149.4	249.0
400	6.5	29.4	58.9	88.3	147.2	245.3
425	5.5	29.1	58.3	87.4	145.7	242.9
450	4.6	28.8	57.7	86.5	144.2	240.4

Temp. °F	ASME Ratings					
	150	300	600	900	1500	2500
	Working Pressure, psig					
-20 to 100	275	720	1440	2160	3600	6000
200	235	620	1240	1860	3095	5160
300	215	560	1120	1680	2795	4660
400	195	515	1025	1540	2570	4280
500	170	480	955	1435	2390	3980
600	140	450	900	1355	2255	3760
650	125	440	885	1325	2210	3680
700	110	435	870	1305	2170	3620
750	95	425	855	1280	2135	3560
800	80	420	845	1265	2110	3520
850	65	420	835	1255	2090	3480

Sour Gas Service/NACE Compliant

Process interface valves for sour gas service are available. Materials are selected in accordance with NACE MR0175/ISO 15156. Contact FITOK Group or our authorized distributors if you have any request.

BB Series: Single Block and Bleed Valves

Instrument Single Block and Bleed Valves

Features

- ⦿ Threaded or one-piece forged body
- ⦿ Orifice (all-ball-valve configuration, ball-and-needle-valve configuration) : Ball 3/8 in. (9.5 mm), Needle 0.16 in. (4 mm); Orifice (all-needle-valve configuration) : 0.16 in. (4 mm) is standard, 0.25 in. (6.4 mm) and 0.38 in. (9.5 mm) are available upon request.

Block: ball Bleed: ball (configuration: BB)

Basic Ordering Number	Inlet/Process	Outlet/Instrument	Vent/Bleed
BB□□-BB-FNS8-V4-C	1/2 female NPT	1/2 female NPT	1/4 female NPT
BB□□-BB-FNS8-V4-CG	1/2 female NPT	1/2 female NPT	1/4 female NPT

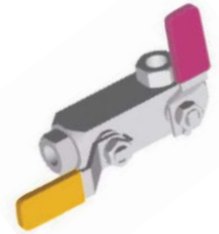
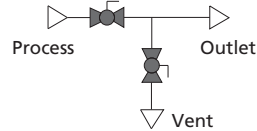
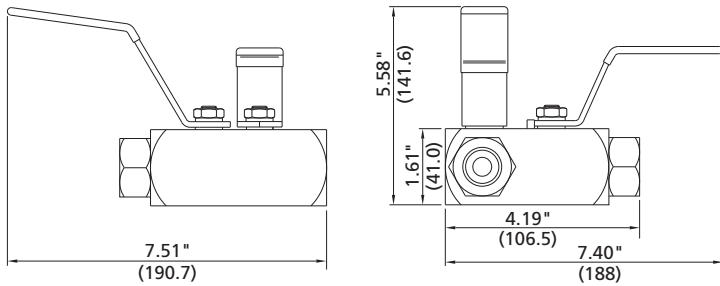

Block: ball Bleed: needle (configuration: BN)

Basic Ordering Number	Inlet/Process	Outlet/Instrument	Vent/Bleed
BB□□-BN-FNS8-V4-V	1/2 female NPT	1/2 female NPT	1/4 female NPT
BB□□-BN-FNS8-V4-VG	1/2 female NPT	1/2 female NPT	1/4 female NPT
BB□□-BN-FNS8-NS8-V4-V	1/2 female NPT	1/2 male NPT	1/4 female NPT
BB□□-BN-FNS8-NS8-V4-VG	1/2 female NPT	1/2 male NPT	1/4 female NPT

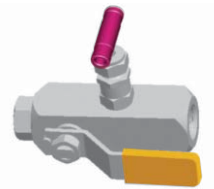
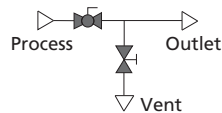
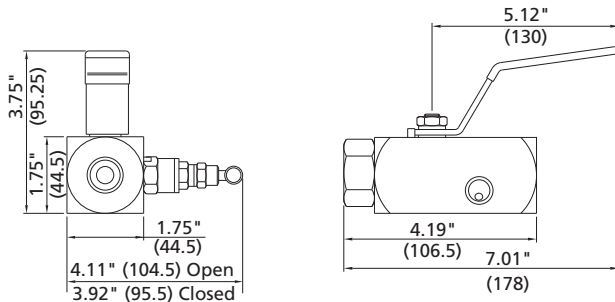

Block: needle Bleed: needle (configuration: NN)

Basic Ordering Number	Inlet/Process	Outlet/Instrument	Vent/Bleed
BB□□-NN-NS8-FNS8-V4-H	1/2 male NPT	1/2 female NPT	1/4 female NPT
BB□□-NN-NS12-FNS8-V4-HG	3/4 male NPT	1/2 female NPT	1/4 female NPT

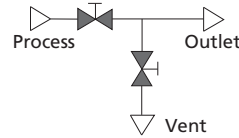
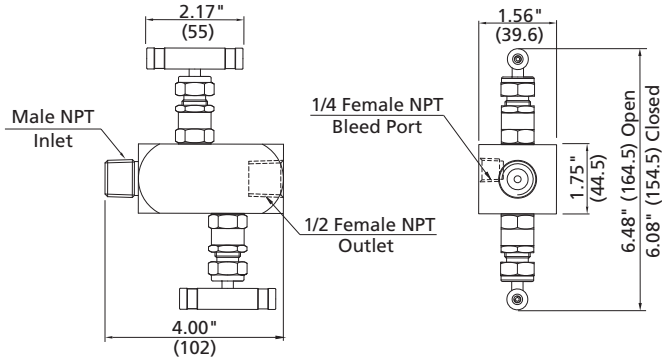

Flange Single Block and Bleed Valves

Features

- ⦿ Threaded or one-piece forged body
- ⦿ Piping and instrument valves in one body
- ⦿ 1/2 female NPT standard outlet
- ⦿ Orifice (ball-and-needle-valve configuration) : Ball 3/8 in. (9.5 mm), Needle 0.16 in. (4 mm);
Orifice (all-ball-valve configuration) : 3/8 in. (9.5 mm)

Block: ball Bleed: needle (configuration: BN)

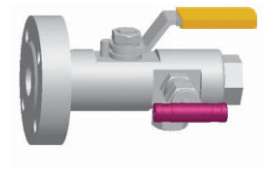
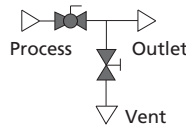
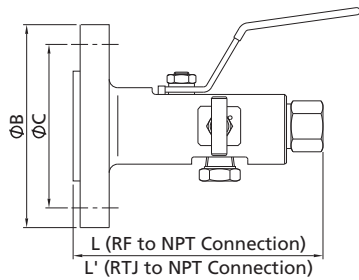

Block: ball Bleed: needle (configuration: BN)

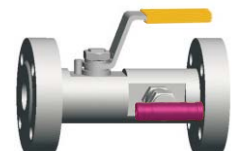
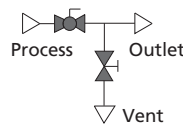
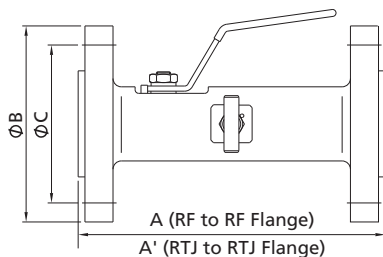

C-30 Block and Bleed Valves

Block: ball Bleed: ball (configuration: BB)

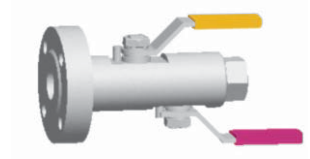
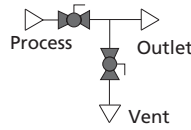
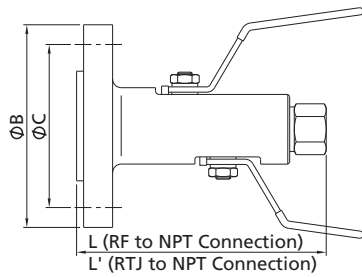

Block: ball Bleed: ball (configuration: BB)

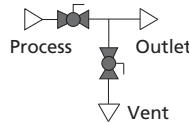
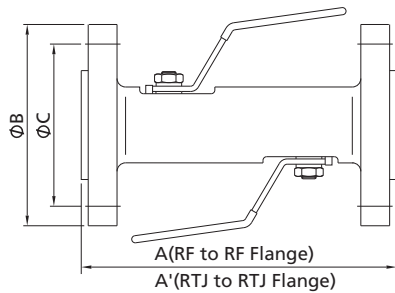

Flange Size	Bore Size in. (mm)	ASME Class	L in. (mm)	L' in. (mm)	A in. (mm)	A' in. (mm)	ϕB in. (mm)	ϕC in. (mm)
NPS 1/2 (DN 15)	3/8 (9.5)	150	4.88 (124.0)	—	6.41 (162.8)	—	3.54 (90)	2.37 (60.3)
		300		4.88 (124.0)	6.81 (173.0)	6.81 (173.0)	3.74 (95)	2.63 (66.7)
		600	5.67 (144.0)	5.67 (144.0)	7.99 (202.9)	7.99 (202.9)	4.72 (120)	3.25 (82.6)
		900/1500		5.67 (144.0)	7.99 (202.9)	7.99 (202.9)	5.31 (135)	3.50 (88.9)
		2500		5.67 (144.0)	7.99 (202.9)	7.99 (202.9)	5.31 (135)	3.50 (88.9)
NPS 3/4 (DN 20)	3/8 (9.5)	150	4.88 (124.0)	—	6.41 (162.8)	—	3.94 (100)	2.75 (69.9)
		300		4.88 (124.0)	6.81 (173.0)	6.81 (173.0)	4.53 (115)	3.25 (82.6)
		600	5.67 (144.0)	5.67 (144.0)	7.99 (202.9)	7.99 (202.9)	5.12 (130)	3.50 (88.9)
		900/1500		5.67 (144.0)	7.99 (202.9)	7.99 (202.9)	5.51 (140)	3.75 (95.2)
		2500		5.67 (144.0)	7.99 (202.9)	7.99 (202.9)	5.51 (140)	3.75 (95.2)
NPS 1 (DN 25)	3/8 (9.5)	150	4.88 (124.0)	4.88 (124.0)	6.41 (162.8)	6.61 (167.9)	4.33 (110)	3.13 (79.4)
		300			7.00 (177.8)	7.00 (177.8)	4.92 (125)	3.50 (88.9)
		600	5.98 (151.9)	5.98 (151.9)	10.30 (261.6)	10.30 (261.6)	5.91 (150)	4.00 (101.6)
		900/1500			10.70 (271.8)	10.70 (271.8)	6.30 (160)	4.25 (108.0)
		2500			10.70 (271.8)	10.70 (271.8)	6.30 (160)	4.25 (108.0)
NPS 1 1/2 (DN 40)	3/8 (9.5)	150	5.98 (151.9)	5.98 (151.9)	8.90 (226.1)	9.49 (241.0)	4.92 (125)	3.87 (98.4)
		300			9.89 (251.2)	9.89 (251.2)	6.10 (155)	4.50 (114.3)
		600	6.61 (167.9)	6.61 (167.9)	11.50 (292.1)	11.50 (292.1)	7.09 (180)	4.87 (123.8)
		900/1500			12.40 (315.0)	12.40 (315.0)	8.07 (205)	5.75 (146)
		2500			12.40 (315.0)	12.40 (315.0)	8.07 (205)	5.75 (146)
NPS 2 (DN 50)	3/8 (9.5)	150	5.98 (151.9)	5.98 (151.9)	9.09 (230.9)	9.49 (241.0)	5.91 (150)	4.75 (120.7)
		300			10.10 (256.5)	10.30 (261.6)	6.50 (165)	5.00 (127.0)
		600	6.61 (167.9)	6.61 (167.9)	12.00 (304.8)	12.00 (304.8)	8.46 (215)	6.50 (165.1)
		900/1500			13.60 (345.4)	13.60 (345.4)	9.25 (235)	6.75 (171.4)
		2500			13.60 (345.4)	13.60 (345.4)	9.25 (235)	6.75 (171.4)

Dimensions are for reference only and are subject to change.

Root Single Block and Bleed Valves

Features

- ⦿ Directly-mounted root valves available to the vessel or process pipe
- ⦿ Weld inlet connection sizes from NPS 1/2 to NPS 2
- ⦿ 1/2 female NPT standard vent with plug
- ⦿ 1/2 female NPT standard outlet
- ⦿ Orifice (ball-and-needle-valve configuration) : Ball 3/8 in. (9.5 mm), Needle 0.16 in. (4 mm);
Orifice (all-needle-valve configuration) : 0.16 in. (4 mm) is standard, 0.25 in. (6.4 mm) and 0.38 in. (9.5 mm) are available upon request.

Block: ball Bleed: needle (configuration: BN)

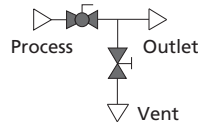
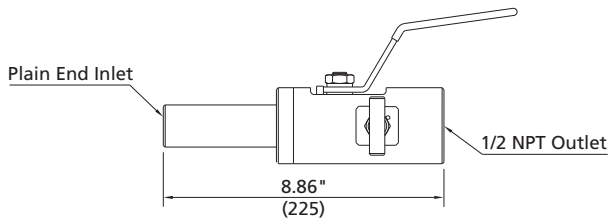

Block: ball Bleed: OS&Y (configuration: BO)

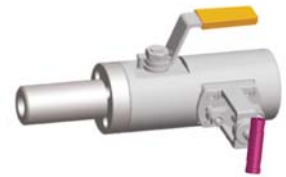
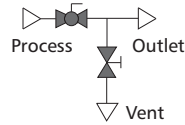
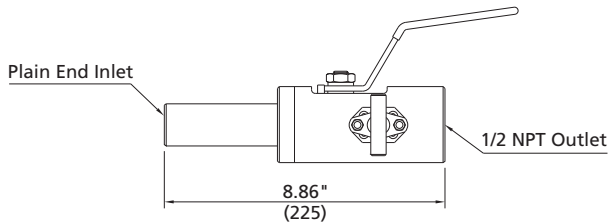

Block: OS&Y Bleed: needle (configuration: ON)

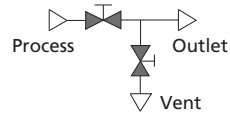
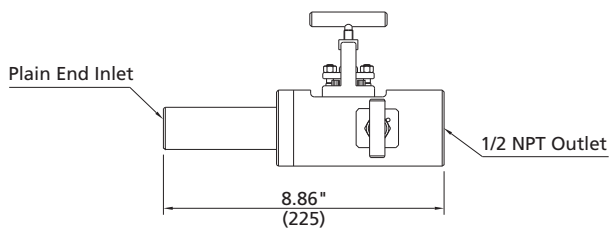

Block: needle Bleed: needle (configuration: NN)

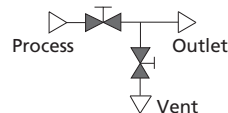
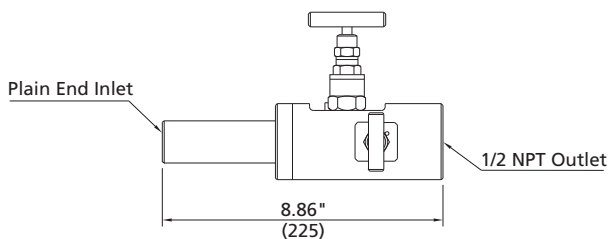

Dimensions are for reference only and are subject to change.

Manifolds

Monoflange Single Block and Bleed Valves

Features

- Piping and instrument valves in one body
- 1/4 female NPT standard vent with plug
- 1/2 female NPT standard outlet
- Orifice: 0.16 in. (4 mm) is standard, 0.25 in. (6.4 mm) and 0.38 in. (9.5 mm) are available for some flange sizes

Block: OS&Y Bleed: needle (configuration: ON)

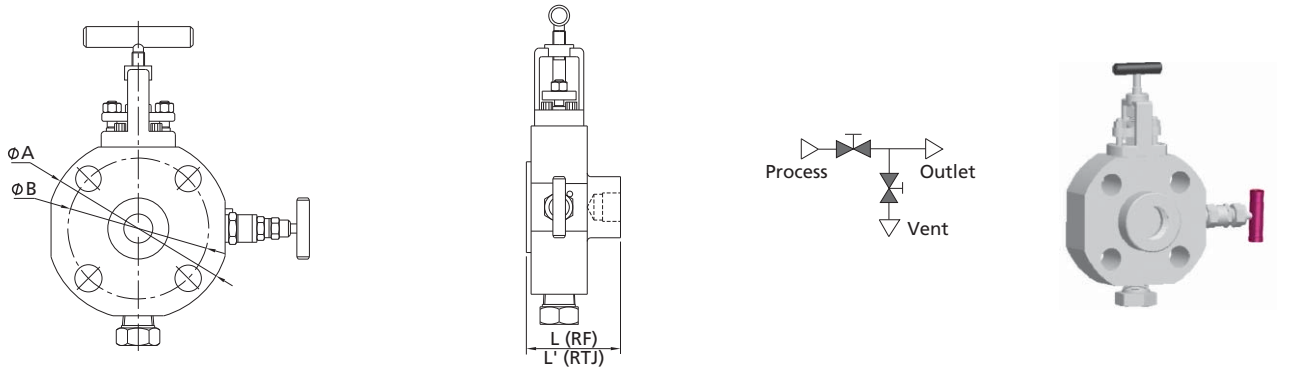

Block: needle Bleed: needle (configuration: NN)

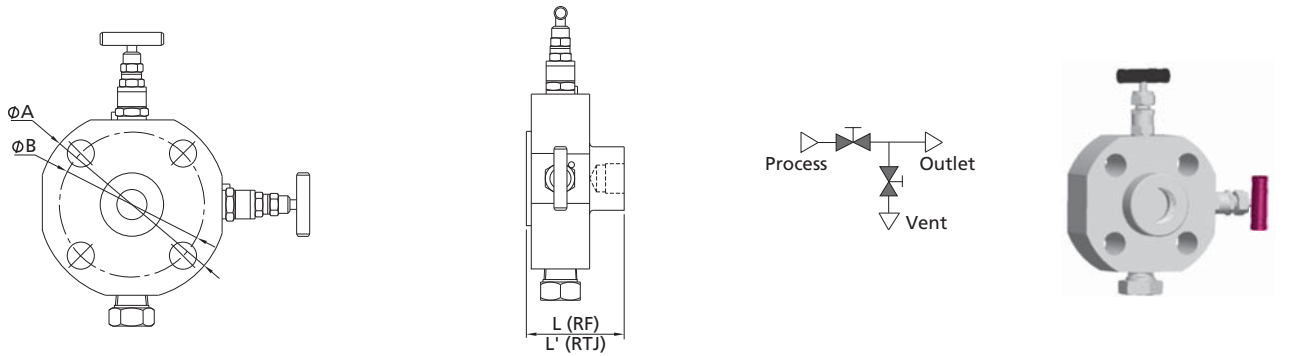

Block: OS&Y Bleed: needle (configuration: ON, Two Vents)

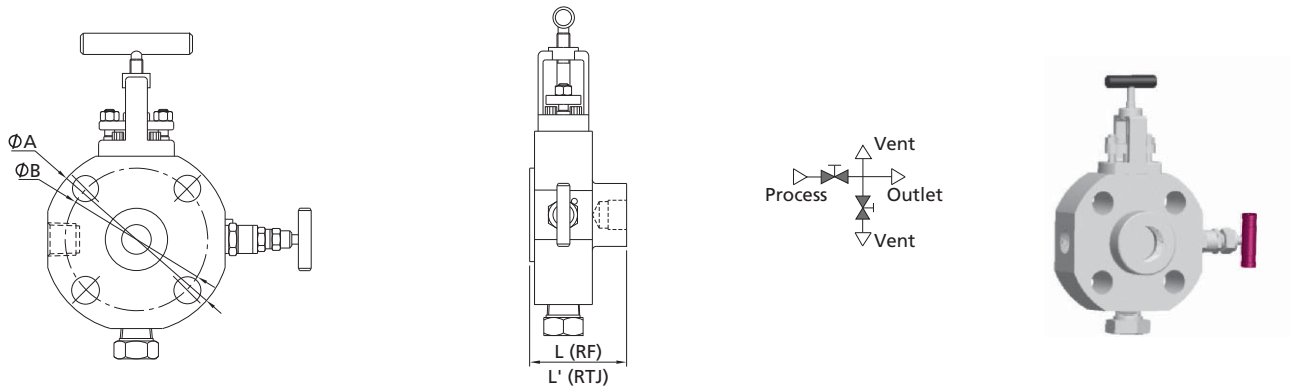

Manifolds

Block: needle Bleed: needle (configuration: NN, Two Vents)

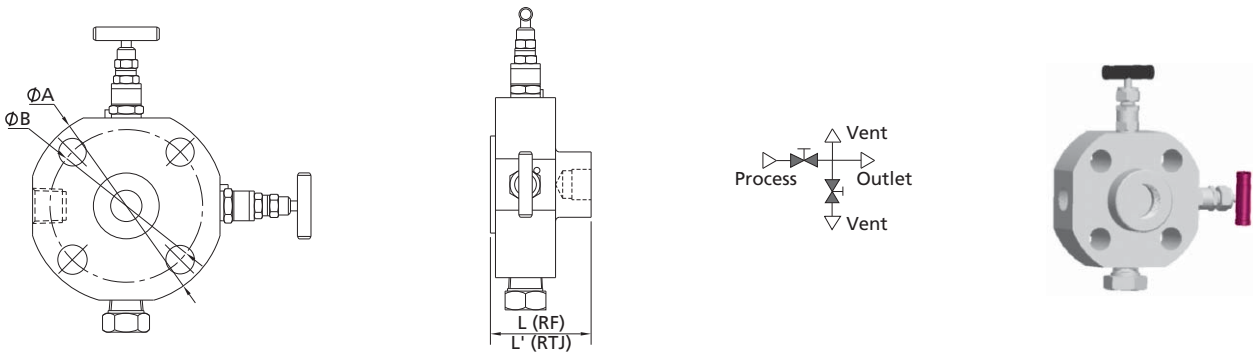

Flange Size	Bore Size in. (mm)	ASME Class	L in. (mm)	L' in. (mm)	Ø A in. (mm)	Ø B in. (mm)
NPS 1/2 (DN 15)	0.16 (4.0)	150	2.03 (51.6)	—	3.54 (90)	2.37 (60.3)
		300		2.03 (51.6)	3.74 (95)	2.63 (66.7)
		600			4.72 (120)	3.25 (82.6)
		900/1500			5.31 (135)	3.50 (88.9)
		2500			3.94 (100)	2.75 (69.9)
NPS 3/4 (DN 20)		150	2.03 (51.6)	2.03 (51.6)	4.53 (115)	3.25 (82.6)
		300			5.12 (130)	3.50 (88.9)
		600			5.51 (140)	3.75 (95.2)
		900/1500			5.91 (150)	4.00 (101.6)
		NPS 1 (DN 25)	150	2.11 (53.5)	2.11 (53.5)	4.33 (110)
300	4.92 (125)		3.50 (88.9)			
600	6.30 (160)		4.25 (108.0)			
900/1500	2.03 (51.6)		2.03 (51.6)			4.92 (125)
NPS 1 1/2 (DN 40)	150		2.11 (53.5)	2.11 (53.5)	6.10 (155)	4.50 (114.3)
	300	7.09 (180)			4.87 (123.8)	
	600	8.07 (205)			5.75 (146)	
	900/1500	2.19 (55.5)			2.19 (55.5)	5.91 (150)
	NPS 2 (DN 50)	150	2.19 (55.5)	2.19 (55.5)	6.50 (165)	5.00 (127.0)
300		8.49 (215)			6.50 (165.1)	
600		9.25 (235)			6.75 (171.4)	
900/1500		2.42 (61.5)			2.42 (61.5)	8.49 (215)
2500		2.88 (73.4)	2.88 (73.4)	9.25 (235)	6.75 (171.4)	

Dimensions are for reference only and are subject to change.

DB Series: Double Block Valves

Monoflange Double Block Valves

Features

- Piping and instrument valves in one body
- 1/2 female NPT standard outlet
- Orifice: 0.16 in. (4 mm) is standard, 0.25 in. (6.4 mm) and 0.38 in. (9.5 mm) are available for some flange sizes

Primary: OS&Y Secondary: needle (configuration: ON)

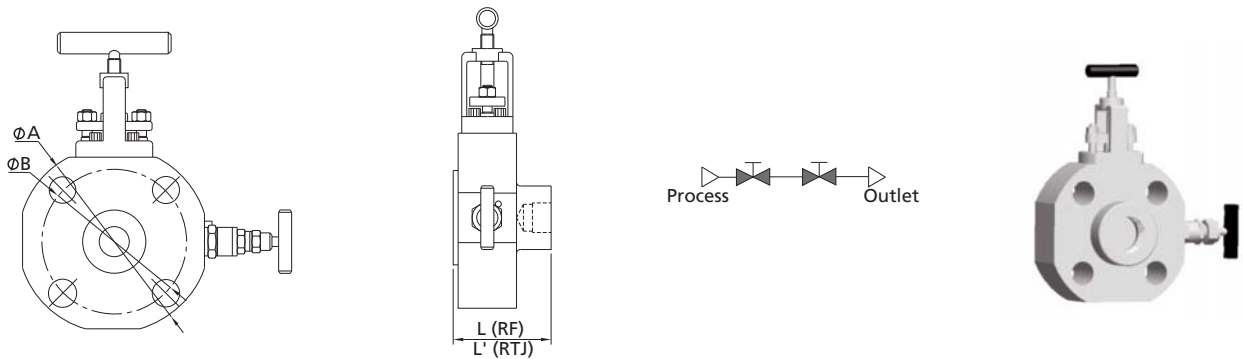

Primary: needle Secondary: needle (configuration: NN)

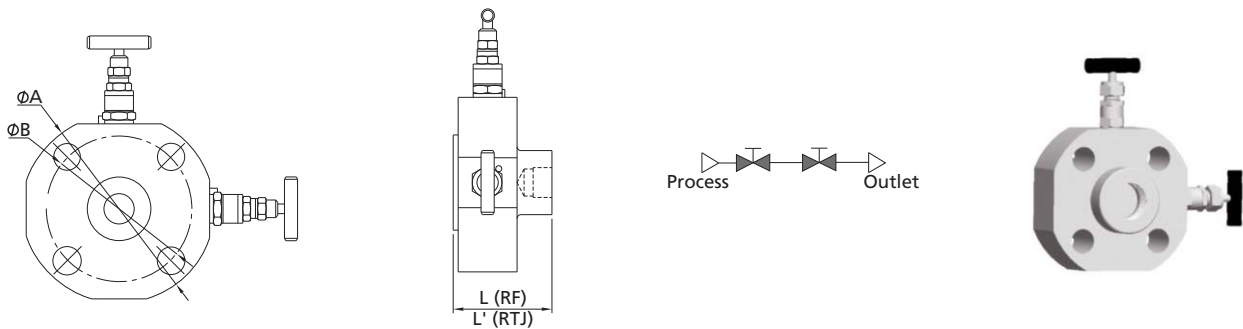

Dimensions are the same as the monoflange single block & bleed valves

SB Series: Single Block Valves

Monoflange Single Block Valves

Features

- Piping and instrument valves in one body
- 1/2 female NPT standard outlet
- Orifice: 0.16 in. (4 mm) is standard, 0.25 in. (6.4 mm) and 0.38 in. (9.5 mm) are available for some flange sizes

Block: OS&Y (O)

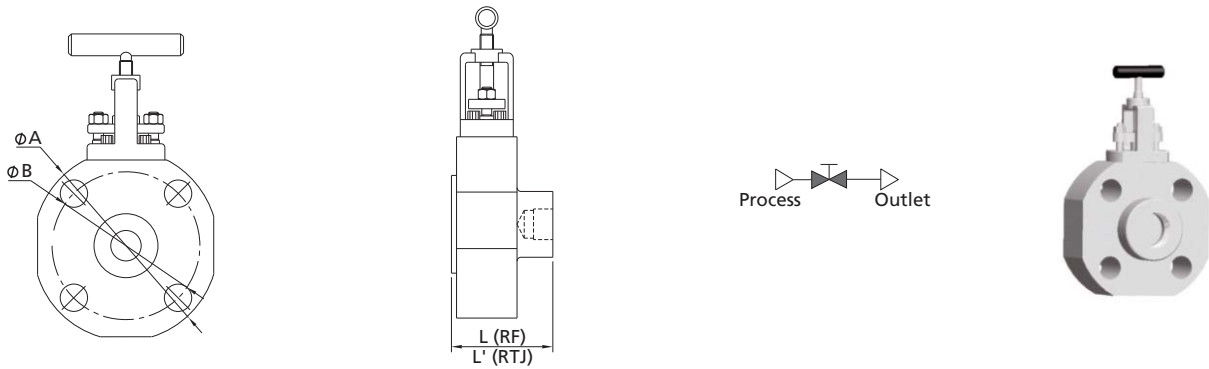

Block: needle (N)

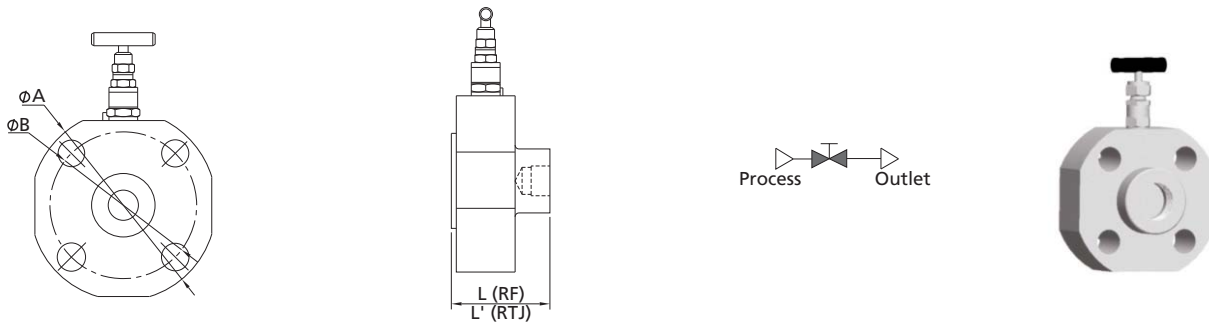

Dimensions are the same as the Monoflange single block & bleed valves

Manifolds

DBB Series: Double Block and Bleed Valves

Instrument Double Block and Bleed Valves

Features

- ⦿ Threaded or one-piece forged body
- ⦿ Optional port sizes and thread forms available
- ⦿ Orifice (all-ball-valve configuration, ball-and-needle-valve configuration) : Ball 3/8 in. (9.5 mm), Needle 0.16 in. (4 mm); Orifice (all-needle-valve configuration) : 0.16 in. (4 mm) is standard, 0.25 in. (6.4 mm) and 0.38 in. (9.5 mm) are available upon request

Primary: ball Secondary: needle Bleed: needle (configuration: BNN)

Basic Ordering Number	Inlet/Process	Outlet/Instrument	Vent/Bleed
DBB□□-BNN-FNS8-V4-V	1/2 female NPT	1/2 female NPT	1/4 female NPT
DBB□□-BNN-FNS8-V4-VG	1/2 female NPT	1/2 female NPT	1/4 female NPT

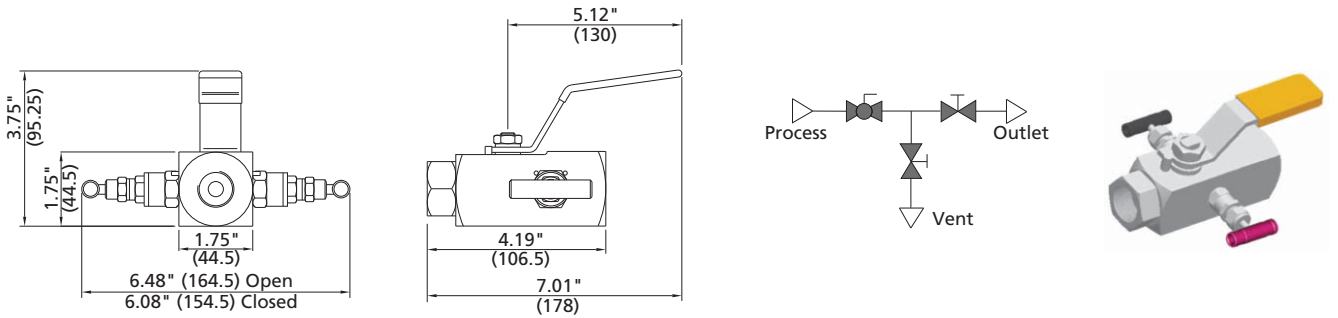

Primary: ball Secondary: ball Bleed: needle (configuration: BBN)

Basic Ordering Number	Inlet/Process	Outlet/Instrument	Vent/Bleed
DBB□□-BBN-FNS8-V4-V	1/2 female NPT	1/2 female NPT	1/4 female NPT
DBB□□-BBN-FNS8-V4-VG	1/2 female NPT	1/2 female NPT	1/4 female NPT

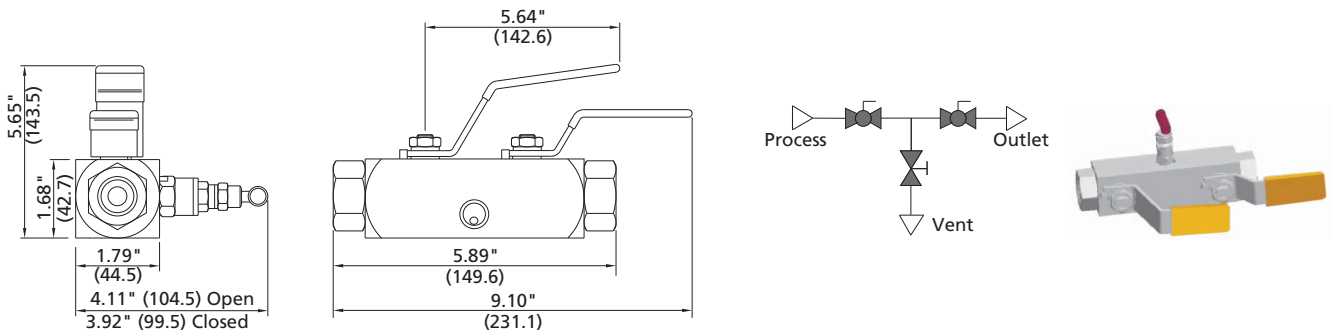

Manifolds

Primary: ball Secondary: ball Bleed: ball (configuration: BBB)

Basic Ordering Number	Inlet/Process	Outlet/Instrument	Vent/Bleed
DBB□□-BBB-FNS8-V4-C	1/2 female NPT	1/2 female NPT	1/4 female NPT
DBB□□-BBB-FNS8-V4-CG	1/2 female NPT	1/2 female NPT	1/4 female NPT

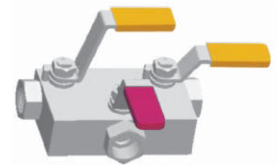
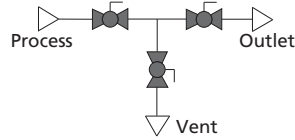
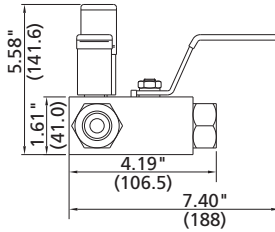
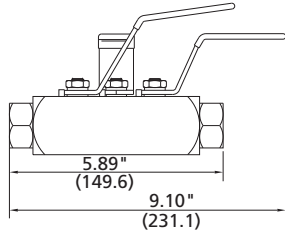

Primary: ball Secondary: ball Bleed: ball (configuration: BBB)

Basic Ordering Number	Inlet/Process	Outlet/Instrument	Vent/Bleed
DBB□□-BBB-FNS8-V4-L	1/2 female NPT	1/2 female NPT	1/4 female NPT
DBB□□-BBB-FNS8-V4-LG	1/2 female NPT	1/2 female NPT	1/4 female NPT

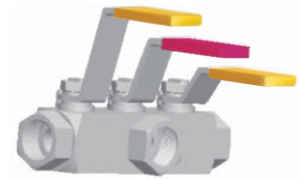
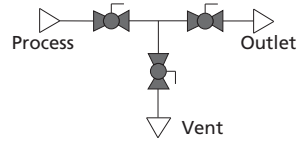
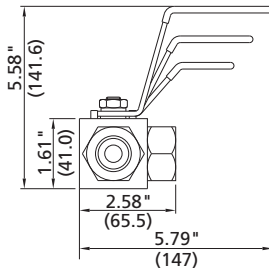
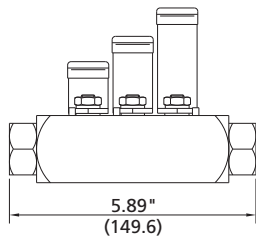

Primary: needle Secondary: needle Bleed: needle (configuration: NNN)

Basic Ordering Number	Inlet/Process	Outlet/Instrument	Vent/Bleed
DBB□□-NNN-NS8-FNS8-V4-V	1/2 male NPT	1/2 female NPT	1/4 female NPT
DBB□□-NNN-NS12-FNS8-V4-VG	3/4 male NPT	1/2 female NPT	1/4 female NPT

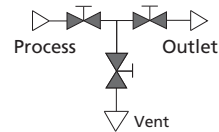
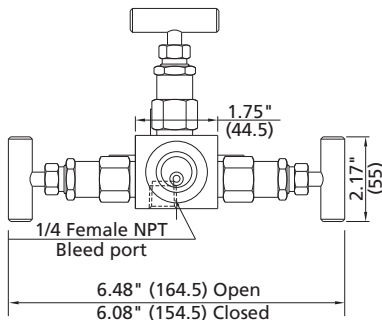
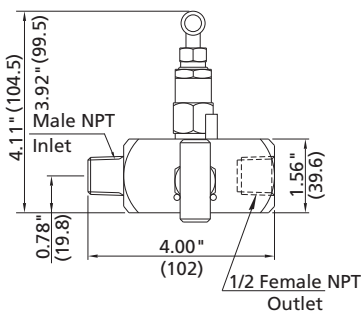

Flange Double Block and Bleed Valves

Features

- ⦿ One piece forged body minimizes potential leak paths
- ⦿ Piping and instrument valves in one body
- ⦿ 1/2 female NPT standard outlet
- ⦿ Orifice (ball-and-needle-valve configuration) : Ball 3/8 in. (9.5 mm), Needle 0.16 in. (4 mm);
Orifice (all-needle-valve configuration) : 0.38 in. (9.5 mm)

Primary: ball Secondary: ball Bleed: needle (configuration: BBN)

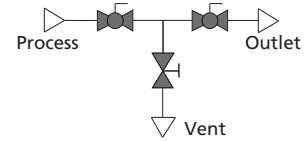
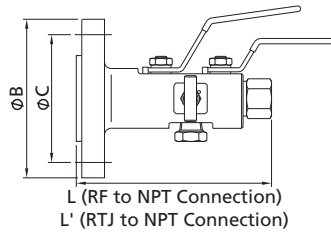
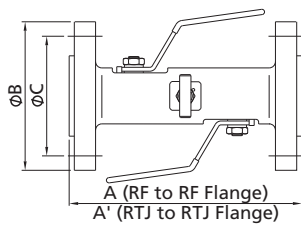

Flange Size	Bore Size in. (mm)	ASME Class	L in. (mm)	L' in. (mm)	A in. (mm)	A' in. (mm)	ØB in. (mm)	ØC in. (mm)				
NPS 1/2 (DN 15)	3/8 (9.5)	150	5.91 (150.1)	—	6.41 (162.8)	—	3.54 (90)	2.37 (60.3)				
		300		5.91 (150.1)	6.81 (173.0)	6.81 (173.0)	3.74 (95)	2.63 (66.7)				
		600	6.69 (170.0)	6.69 (170.0)	7.99 (202.9)	7.99 (202.9)	4.72 (120)	3.25 (82.6)				
		900/1500					5.31 (135)	3.50 (88.9)				
		2500					5.31 (135)	3.50 (88.9)				
NPS 3/4 (DN 20)	3/8 (9.5)	150	5.91 (150.1)	—	6.41 (162.8)	—	3.94 (100)	2.75 (69.9)				
		300		5.91 (150.1)	6.81 (173.0)	6.81 (173.0)	4.53 (115)	3.25 (82.6)				
		600	6.69 (170.0)	6.69 (170.0)	7.99 (202.9)	7.99 (202.9)	5.12 (130)	3.50 (88.9)				
		900/1500					5.51 (140)	3.75 (95.2)				
		2500					5.51 (140)	3.75 (95.2)				
NPS 1 (DN 25)	3/8 (9.5)	150	5.91 (150.1)	5.91 (150.1)	6.41 (162.8)	6.61 (167.9)	4.33 (110)	3.13 (79.4)				
		300			7.00 (177.8)	7.00 (177.8)	4.92 (125)	3.50 (88.9)				
		600	7.00 (177.8)	7.00 (177.8)	8.90 (226.1)	9.49 (241.0)	4.92 (125)	3.87 (98.4)				
		900/1500							10.30 (261.6)	10.30 (261.6)	5.91 (150)	4.00 (101.6)
		2500							10.70 (271.8)	10.70 (271.8)	6.30 (160)	4.25 (108.0)
NPS 1 1/2 (DN 40)	3/8 (9.5)	150	7.00 (177.8)	7.00 (177.8)	8.90 (226.1)	9.49 (241.0)	4.92 (125)	3.87 (98.4)				
		300			9.89 (251.2)	9.89 (251.2)	6.10 (155)	4.50 (114.3)				
		600	7.64 (194.1)	7.64 (194.1)	11.50 (292.1)	11.50 (292.1)	7.09 (180)	4.87 (123.8)				
		900/1500					12.40 (315.0)	12.40 (315.0)	8.07 (205)	5.75 (146)		
		2500					12.40 (315.0)	12.40 (315.0)	8.07 (205)	5.75 (146)		
NPS 2 (DN 50)	3/8 (9.5)	150	7.00 (177.8)	7.00 (177.8)	9.09 (230.9)	9.49 (241.0)	5.91 (150)	4.75 (120.7)				
		300			10.10 (256.5)	10.30 (261.6)	6.50 (165)	5.00 (127.0)				
		600	7.64 (194.1)	7.64 (194.1)	12.00 (304.8)	12.00 (304.8)	8.46 (215)	6.50 (165.1)				
		900/1500					8.03 (204.0)	8.03 (204.0)	9.25 (235)	6.75 (171.4)		
		2500					8.03 (204.0)	8.03 (204.0)	9.25 (235)	6.75 (171.4)		

Manifolds

Primary: OS&Y Secondary: OS&Y Bleed: needle (configuration: OON)

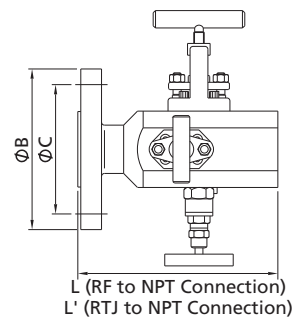
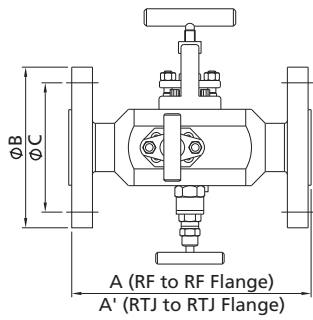

Flange Size	Bore Size in. (mm)	ASME Class	L in. (mm)	L' in. (mm)	A in. (mm)	A' in. (mm)	ϕB in. (mm)	ϕC in. (mm)
NPS 1/2 (DN 15)	0.38 (9.5)	150	4.88 (124.0)	—	6.41 (162.8)	—	3.54 (90)	2.37 (60.3)
		300		4.88 (124.0)	6.81 (173.0)	6.81 (173.0)	3.74 (95)	2.63 (66.7)
		600	5.60 (142.2)	5.60 (142.2)	7.99 (202.9)	7.99 (202.9)	4.72 (120)	3.25 (82.6)
		900/1500					5.31 (135)	3.50 (88.9)
		2500					5.31 (135)	3.50 (88.9)
NPS 3/4 (DN 20)	0.38 (9.5)	150	4.88 (124.0)	—	6.41 (162.8)	—	3.94 (100)	2.75 (69.9)
		300		4.88 (124.0)	6.81 (173.0)	6.81 (173.0)	4.53 (115)	3.25 (82.6)
		600	5.60 (142.2)	5.60 (142.2)	7.99 (202.9)	7.99 (202.9)	5.12 (130)	3.50 (88.9)
		900/1500					5.51 (140)	3.75 (95.2)
		2500					5.51 (140)	3.75 (95.2)
NPS 1 (DN 25)	0.38 (9.5)	150	4.88 (124.0)	4.88 (124.0)	6.41 (162.8)	6.61 (167.9)	4.33 (110)	3.13 (79.4)
		300			7.00 (177.8)	7.00 (177.8)	4.92 (125)	3.50 (88.9)
		600	5.98 (151.9)	5.98 (151.9)	8.90 (226.1)	9.49 (241.0)	10.30 (261.6)	4.00 (101.6)
		900/1500					10.70 (271.8)	4.25 (108.0)
		2500					10.70 (271.8)	4.25 (108.0)
NPS 1 1/2 (DN 40)	0.38 (9.5)	150	5.98 (151.9)	5.98 (151.9)	8.90 (226.1)	9.49 (241.0)	4.92 (125)	3.87 (98.4)
		300			9.89 (251.2)	9.89 (251.2)	6.10 (155)	4.50 (114.3)
		600	6.61 (167.9)	6.61 (167.9)	11.50 (292.1)	11.50 (292.1)	7.09 (180)	4.87 (123.8)
		900/1500					12.40 (315.0)	5.75 (146)
		2500					12.40 (315.0)	5.75 (146)
NPS 2 (DN 50)	0.38 (9.5)	150	5.98 (151.9)	5.98 (151.9)	9.09 (230.9)	9.49 (241.0)	5.91 (150)	4.75 (120.7)
		300			10.10 (256.5)	10.30 (261.6)	6.50 (165)	5.00 (127.0)
		600	6.61 (167.9)	6.61 (167.9)	12.00 (304.8)	12.00 (304.8)	8.46 (215)	6.50 (165.1)
		900/1500					13.60 (345.4)	6.75 (171.4)
		2500					13.60 (345.4)	6.75 (171.4)

Three-Piece Bolted Flange Double Block and Bleed Valves

Features

- ⦿ Complementing the existing one-piece range, flange to flange bolted construction DBB valves available in bore sizes from 3/8 in. to 2 in. (9.5 mm ~ 50.8 mm)
- ⦿ Designed and manufactured according to ASME SI B16.34 and ASME Boiler and Pressure Vessel Code, Section VIII
- ⦿ Three-piece, bolted joint, forged body design
- ⦿ API 607 Fire safe approved by TÜV SÜD. Anti-static design is also available.
- ⦿ Blowout-proof valve stems and needles
- ⦿ Materials are selected in accordance with NACE MR0175/ISO 15156
- ⦿ 1/2 female NPT standard vent

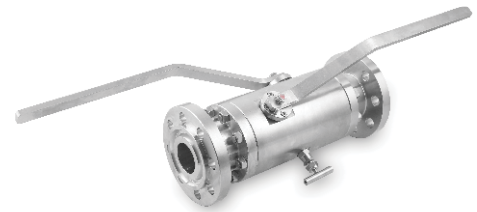
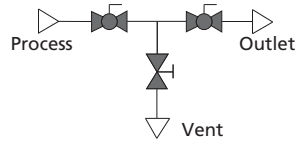
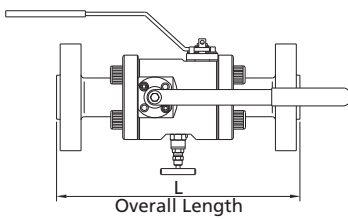

Dimensions

Basic Ordering Number	Flange Size	Bore Size in. (mm)	ASME Class	L in. (mm)
DBB□□-BBN1-□□8□□□-V□-FS-I	NPS 1/2 (DN 15)	1/2 (14)	150	12.6 (321)
			300	12.9 (327)
			600	13.4 (340)
			900/1500	14.4 (366)
			2500	15.0 (382)
DBB□□-BBN2-□□12□□□-V□-FS-I	NPS 3/4 (DN 20)	3/4 (20)	150	12.7 (323)
			300	13.2 (336)
			600	13.7 (349)
			900/1500	14.6 (372)
			2500	15.2 (385)
DBB□□-BBN3-□□16□□□-V□-FS-I	NPS 1 (DN 25)	1 (25.4)	150	13.0 (330)
			300	13.2 (336)
			600	13.8 (350)
			900/1500	15.4 (392)
			2500	16.2 (412)
DBB□□-BBN4-□□24□□□-V□-FS-I	NPS 1 1/2 (DN 40)	1 1/2 (38.1)	150	14.2 (361)
			300	14.4 (367)
			600	15.1 (384)
			900/1500	15.8 (402)
			2500	18.2 (463)
DBB□□-BBN5-□□32□□□-V□-FS-I	NPS 2 (DN 50)	2 (50.8)	150	15.4 (390)
			300	15.7 (398)
			600	16.4 (416)
			900/1500	18.9 (481)

Basic Ordering Number	Flange Size	Bore Size in. (mm)	ASME Class	L in. (mm)
DBB□□-BBN-□□8□□□-V□-FS-I	NPS 1/2 (DN 15)	3/8 (9.5)	150	9.1 (232)
			300	9.9 (252)
			600	10.7 (272)
			900/1500	12.3 (312)
			2500	13.5 (342)
DBB□□-BBN1-□□12□□□-V□-FS-I	NPS 3/4 (DN 20)	1/2 (14)	150	12.8 (324)
			300	13.2 (336)
			600	13.8 (350)
			900/1500	14.6 (372)
			2500	15.2 (385)
DBB□□-BBN2-□□16□□□-V□-FS-I	NPS 1 (DN 25)	3/4 (20)	150	12.9 (327)
			300	13.4 (340)
			600	13.9 (353)
			900/1500	15.1 (384)
			2500	15.6 (397)
DBB□□-BBN3-□□24□□□-V□-FS-I	NPS 1 1/2 (DN 40)	1 (25.4)	150	13.1 (332)
			300	13.9 (352)
			600	15.0 (382)
			900/1500	15.8 (402)
			2500	16.6 (422)
DBB□□-BBN4-□□32□□□-V□-FS-I	NPS 2 (DN 50)	1 1/2 (38.1)	150	12.3 (312)
			300	13.1 (332)
			600	13.9 (352)
			900/1500	15.8 (402)
			2500	16.6 (422)
DBB□□-BBN5-□□48□□□-V□-FS-I	NPS 3 (DN 80)	2 (50.8)	150	14.3 (364)
			300	14.6 (372)
			600	16.9 (428)
			900	17.4 (441)
			1500	19.7 (500)

Dimensions are for reference only and are subject to change.

Root Double Block and Bleed Valves

Features

- ⦿ Directly-mounted root valves available to the vessel or process pipe
- ⦿ Weld inlet connections in sizes from NPS 1/2 to NPS 2
- ⦿ 1/2 female NPT standard vent with plug
- ⦿ 1/2 female NPT standard outlet
- ⦿ Orifice (ball-and-needle-valve configuration): Ball 3/8 in. (9.5 mm), Needle 0.16 in. (4 mm);
Orifice (all-needle-valve configuration): 0.16 in. (4 mm) is standard, 0.25 in. (6.4 mm) and 0.38 in. (9.5 mm) are available upon request.

Primary: ball Secondary: ball Bleed: needle (configuration: BBN)

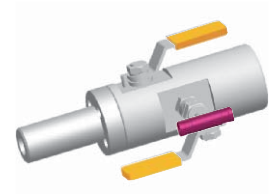
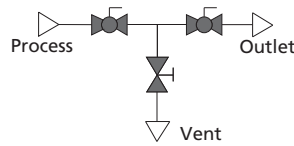
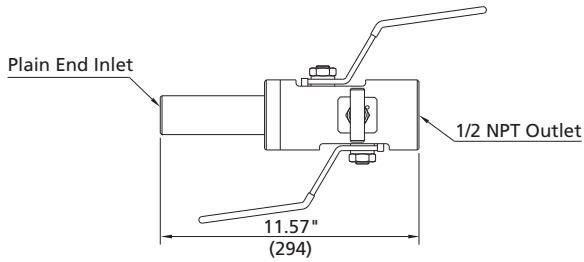

Primary: ball Secondary: ball Bleed: OS&Y (configuration: BBO)

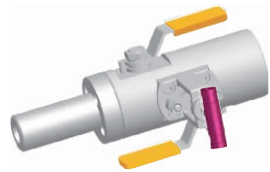
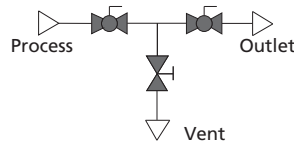
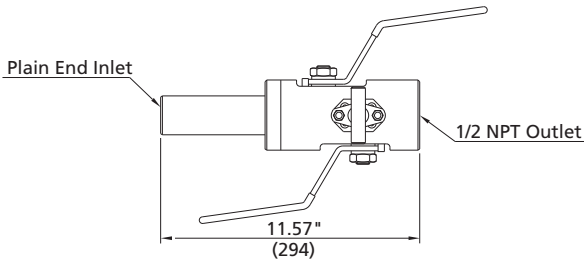

Primary: OS&Y Secondary: OS&Y Bleed: needle (configuration: OON)

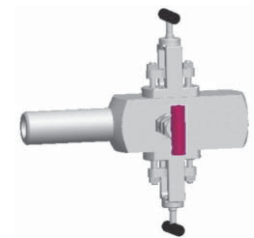
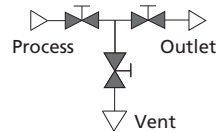
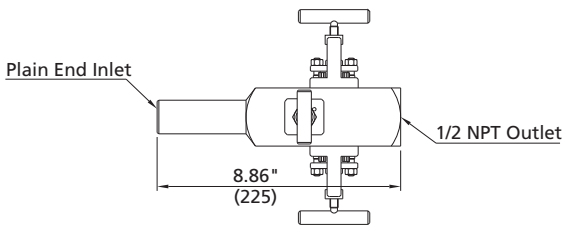

Primary: needle Secondary: needle Bleed: needle (configuration: NNN)

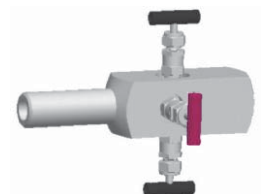
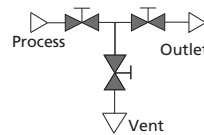
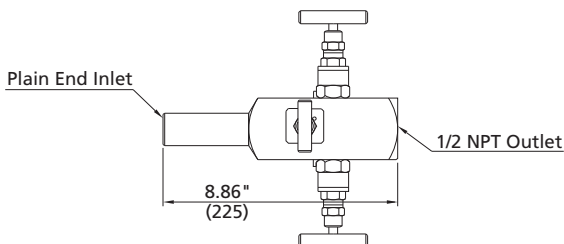

Dimensions are for reference only and are subject to change.

Monoflange Double Block & Bleed Valves

Features

- Piping and instrument valves in one body
- 1/4 female NPT standard vent with plug
- 1/2 female NPT standard outlet
- Orifice: 0.16 in. (4 mm) is standard, 0.25 in. (6.4 mm) and 0.38 in. (9.5 mm) are available for some flange sizes

Primary: OS&Y Secondary: needle Bleed: needle (configuration: ONN)

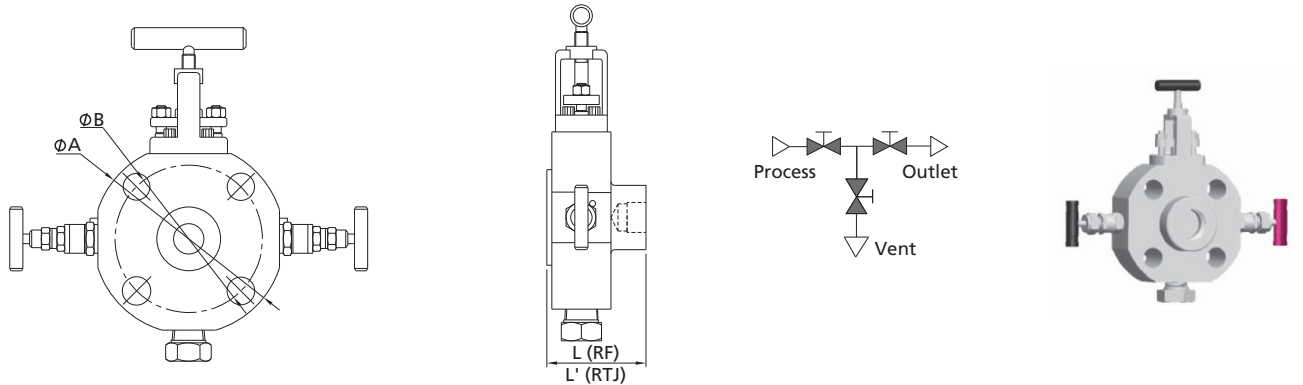

Primary: needle Secondary: needle Bleed: needle (configuration: NNN)

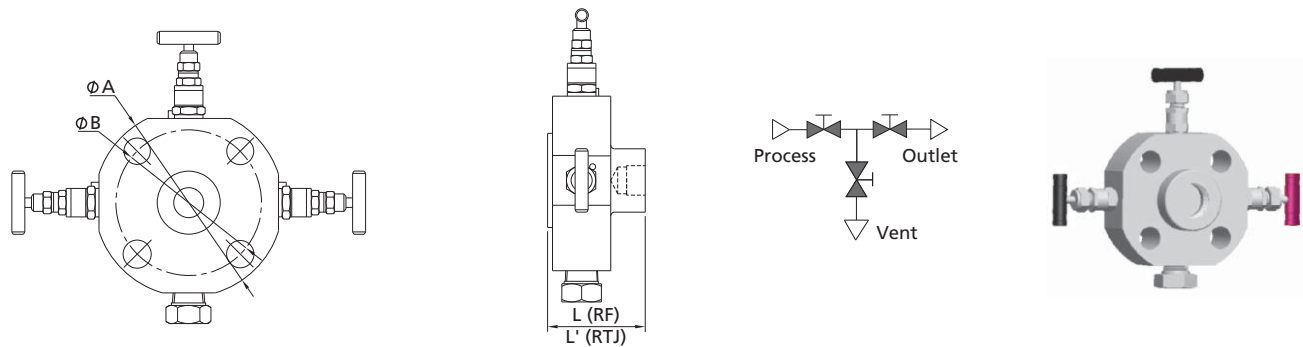

Primary: OS&Y Secondary: needle Bleed: needle (configuration: ONN, Block/Block/Bleed: X)

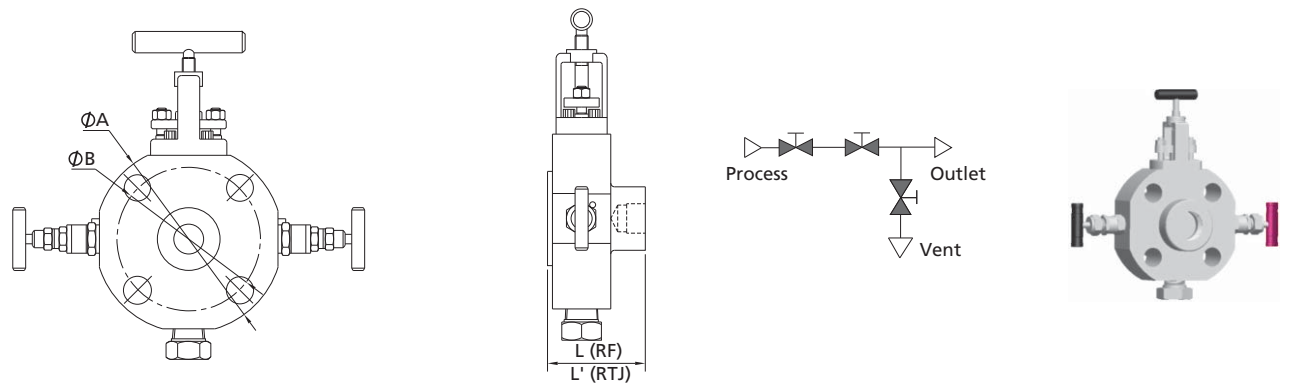

Manifolds

C-44 Block and Bleed Valves

Primary: needle Secondary: needle Bleed: needle (configuration: NNN, Block/Block/Bleed: X)

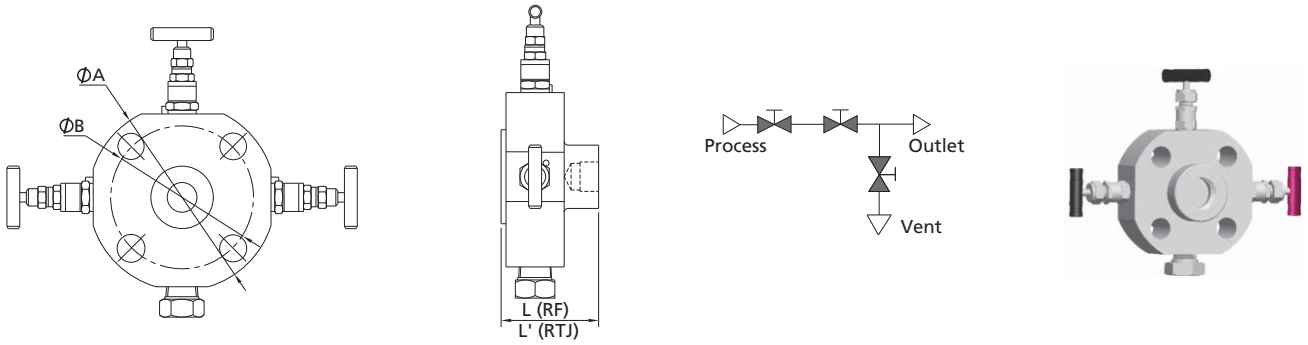

Flange Size	Bore Size in. (mm)	ASME Class	L in. (mm)	L' in. (mm)	ØA in. (mm)	ØB in. (mm)		
NPS 1/2 (DN 15)	0.16 (4.0)	150	2.03 (51.6)	—	3.54 (90)	2.37 (60.3)		
		300		2.03 (51.6)	3.74 (95)	2.63 (66.7)		
		600			4.72 (120)	3.25 (82.6)		
		900/1500			5.31 (135)	3.50 (88.9)		
		2500			—	3.94 (100)	2.75 (69.9)	
NPS 3/4 (DN 20)	0.16 (4.0)	150	2.03 (51.6)	2.03 (51.6)	4.53 (115)	3.25 (82.6)		
		300			5.12 (130)	3.50 (88.9)		
		600			2.11 (53.5)	2.11 (53.5)	5.51 (140)	3.75 (95.2)
		900/1500			—	4.33 (110)	3.13 (79.4)	
		2500	2.11 (53.5)	2.11 (53.5)	5.91 (150)	4.00 (101.6)		
NPS 1 (DN 25)	0.16 (4.0)	150	2.03 (51.6)	2.03 (51.6)	4.92 (125)	3.50 (88.9)		
		300			6.30 (160)	4.25 (108.0)		
		600			2.03 (51.6)	2.03 (51.6)	4.92 (125)	3.87 (98.4)
		900/1500	2.11 (53.5)	2.11 (53.5)	7.09 (180)	4.87 (123.8)		
		2500	2.67 (67.9)	2.67 (67.9)	8.07 (205)	5.75 (146)		
NPS 1 1/2 (DN 40)	0.16 (4.0)	150	2.11 (53.5)	2.11 (53.5)	5.91 (150)	4.75 (120.7)		
		300			6.50 (165)	5.00 (127.0)		
		600			2.19 (55.5)	2.19 (55.5)	6.50 (165)	5.00 (127.0)
		900/1500	2.42 (61.5)	2.42 (61.5)	8.46 (215)	6.50 (165.1)		
		2500	2.88 (73.4)	2.88 (73.4)	9.25 (235)	6.75 (171.4)		

Dimensions are for reference only and are subject to change.

Injection Double Block & Bleed Valves

Function - injection

Injection of chemicals and other media into the process stream can be accomplished with this design. A check valve is installed to prevent process fluid from reaching the inlet injection position. There is a 0.125" (3 mm) hole in the injection nozzle orifice. The length of the injection nozzle orifice can be manufactured to meet customer requirements. The injection orifice can also be rotated. Injection valves can be provided in most of the styles and options offered for the DBB ranges.

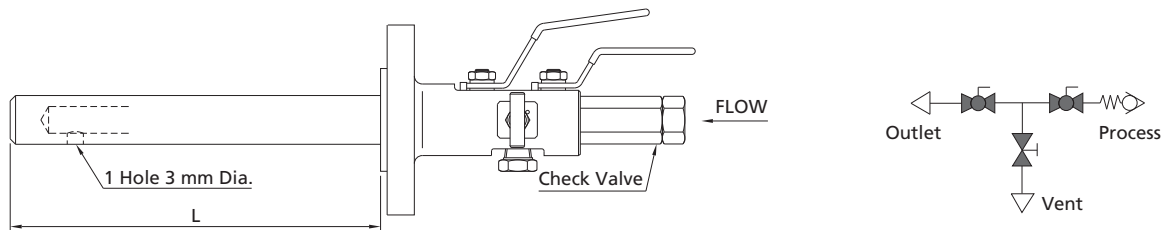

Injection Quill

The injection quill length (L) is manufactured to meet customer requirements. The injection nozzle is a 3 mm diameter hole (standard).

Integral Check Valve

This poppet type spring return valve has a FKM soft seal (standard).

Sampling Double Block & Bleed Valves

Function - sampling

This design is developed to remove a sample directly from process stream at full system pressure. The customized sampling probe extends from the pipe flange connection for correct sample removal. Sampling valves can be provided without a probe and valves can be provided in most of the styles and options offered for the DBB ranges.

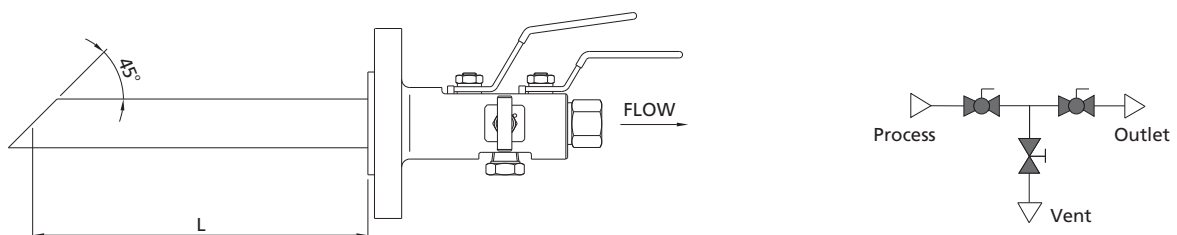

Sampling Probe

The sampling probe length (L) is manufactured to meet customer requirements.

Ordering Number Description

DBSS - 1BBO1 - FM16300 - FNS8 - 2V8 - HGSF2 - IE

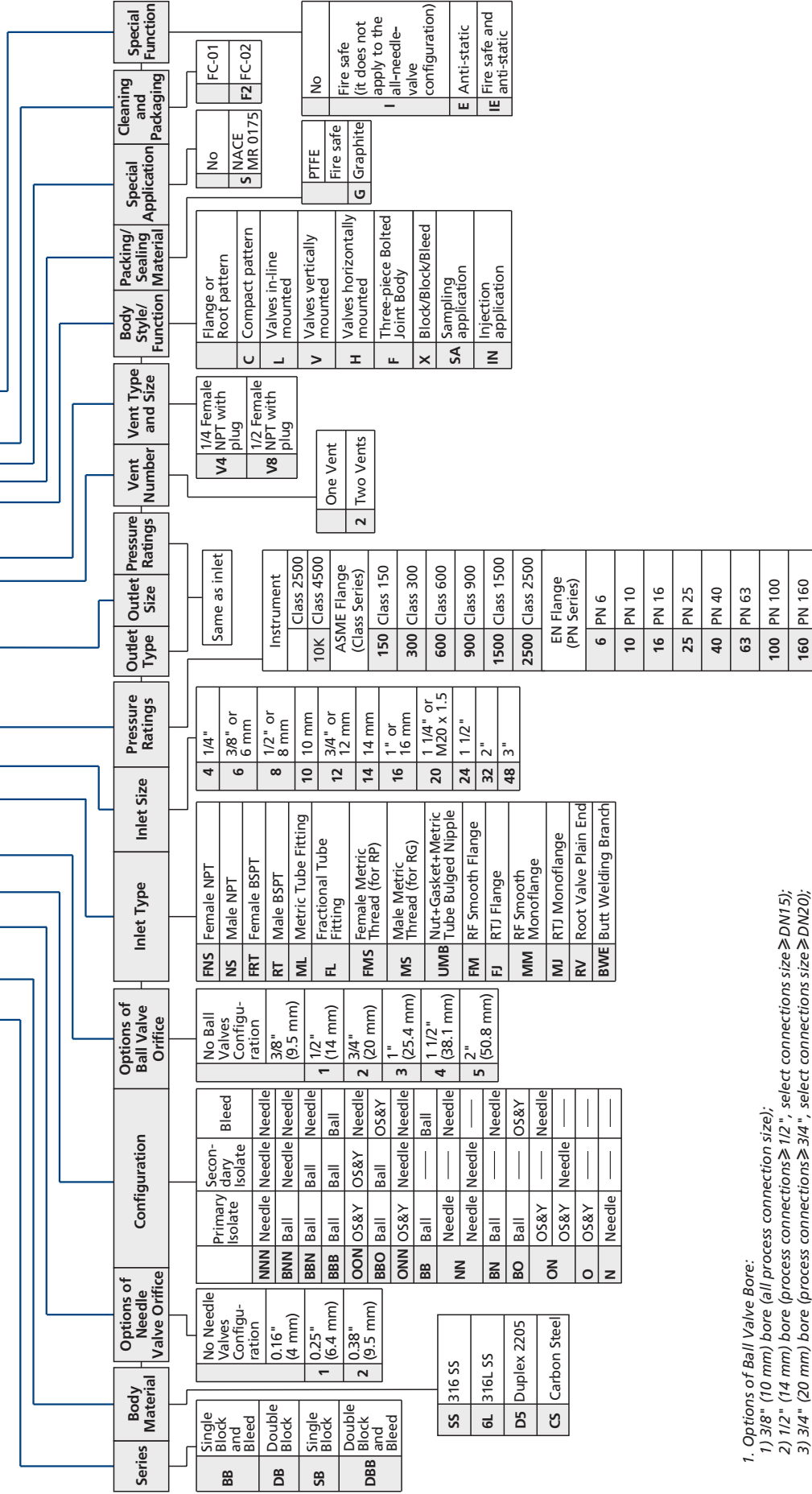

- Options of Ball Valve Bore:
 - 3/8" (10 mm) bore (all process connection size);
 - 1/2" (14 mm) bore (process connections $\geq 1/2"$, select connections size $\geq DN15$);
 - 3/4" (20 mm) bore (process connections $\geq 3/4"$, select connections size $\geq DN20$);
 - 1" (25.4 mm) bore (process connections $\geq 1"$, select connections size $\geq DN25$);
 - 1-1/2" (38.1 mm) bore (process connections $\geq 1-1/2"$, select connections size $\geq DN40$);
 - 2" (50.8 mm) bore (process connections $\geq 2"$, select connections size $\geq DN50$).
- For more information about hazards and risks of oxygen-enriched system, please contact FITOK Group or our authorized distributors.
- Cleaning and Packaging:
 - FC-01: Standard cleaning and packaging for general industrial procedures.
 - FC-02: Special cleaning and packaging for wetted system components to ensure compliance with product cleanliness requirement as stated in ASTM G93 Level C.

NOTE: "Ordering Number Description" is a reference to understand the combination rules of FITOK product part number. Not all combinations are available.

Air Headers and Distribution Manifolds

AH and CM Series



Air Headers
Distribution Manifolds

AH Series Air Headers

Features

- ⦿ Working pressure up to 1000 psig
- ⦿ Working temperature: 0 to 250°F (-18 to 121°C)
- ⦿ Modular design for easy installation and maintenance
- ⦿ Standard module with 4 or 6 outlets available as an accessory and can be ordered separately
- ⦿ Multiple choices of inlet and vent types, and in-line replacement available
- ⦿ Every air header leak tested at factory with air or Nitrogen at rated working pressure

Major Materials of Construction

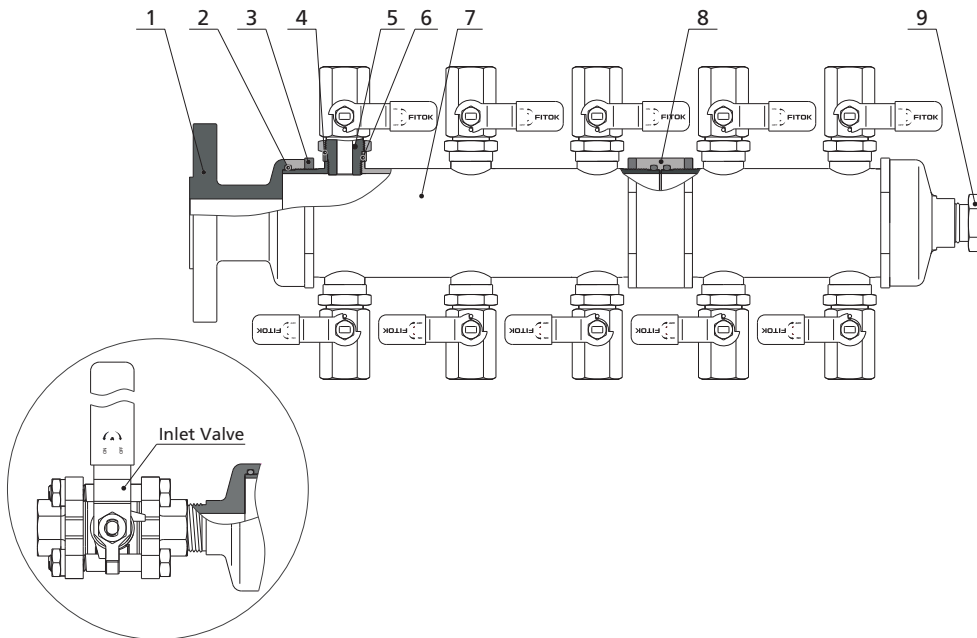

Item	Component	Material	
1	Inlet Valve	BG series ball valves	
	Flange/Fitting	316 SS	304 SS
2	O-ring	NBR	
3	Lock Nut	304 SS	
4	Support Ring	304 SS	
5	Outlet Valve	BR series ball valves	
6	Seal Ring	PTFE	
7	Main Line	316 SS	304 SS
8	Connection Nut	316 SS	304 SS
9	Plug	316 SS	304 SS

Standard Connection Types

Port	Connection Type	Specification	Standard
Inlet	Female NPT	1"	ASME B1.20.1
	Flange	Class 150, Class 300	ASME B16.5
		PN16, PN25, PN40	EN1092, GB/T9115
Outlet	Female NPT	1/2"	ASME B1.20.1
Vent	Female NPT	1/2"	ASME B1.20.1

Note: The connections listed above are standard. For other connection types, refer to "Ordering Number Description".

Ordering information and Dimensions

Dimensions, in inches (millimeters), are for reference only and are subject to change.

Air Header

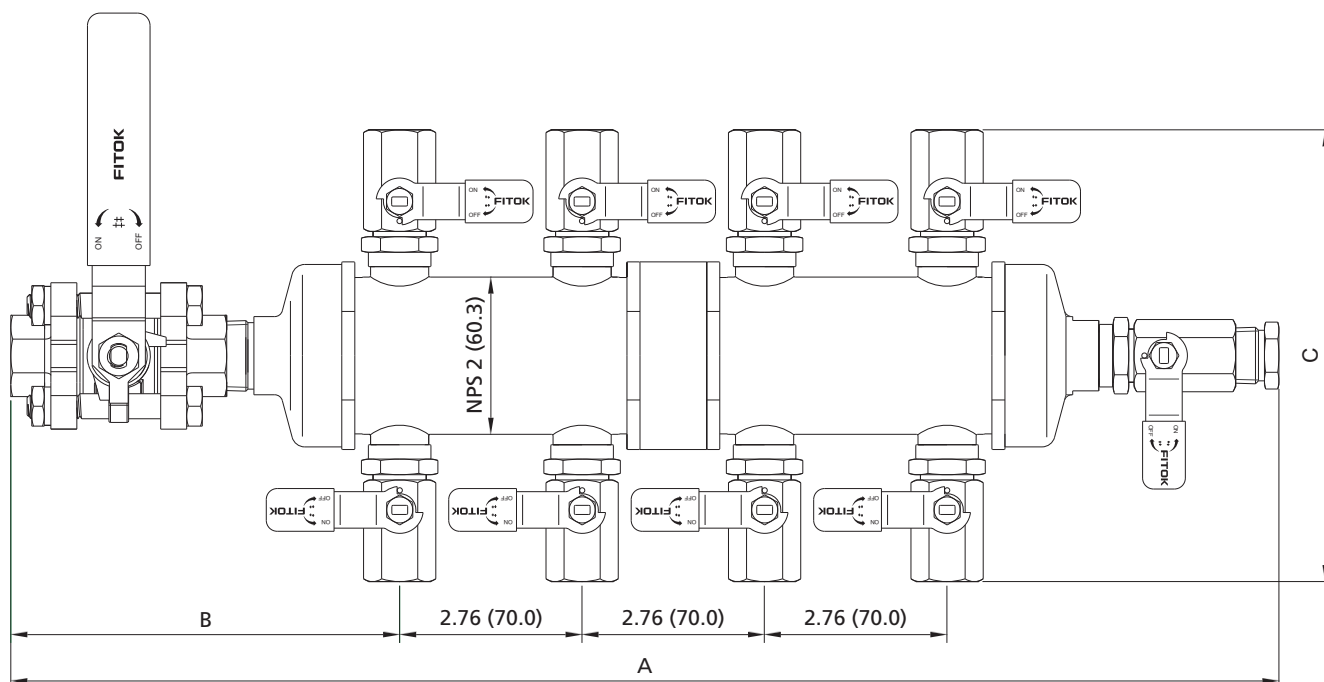

Basic Ordering Number	Connection Type and Size	Dimensions, in. (mm)		
		A	B	C
AH□□-AM16-8FNS8-FNS8	Inlet: 1" Class 150 RF flange; Outlet: 8 outlets, 1/2" Female NPT; Vent: 1/2" female NPT with plug	14.60 (370.8)	3.39 (86.0)	6.81 (173.0)
AH□□-FNS8-4FL4Y-FNS8	Inlet: 1/2" Female NPT; Outlet: 4 outlets, 1/4" FITOK tube fitting with plug; Vent: 1/2" female NPT with plug	8.00 (203.0)	2.29 (58.2)	9.71 (246.7)
AH□□-FNS12Y-8FNS8-VPFNS8	Inlet: 3/4" Female NPT with BG series ball valve; Outlet: 8 outlets, 1/2" Female NPT; Vent: 1/2" Female NPT with valve and plug	19.80 (503.0)	6.61 (168.0)	6.81 (173.0)

For a complete ordering number, add a material designator to the basic ordering number. For other materials and connections, please contact the FITOK Group or our authorized distributors.

Accessory - Standard Module

Includes: main line, outlet valve, lock nut, support ring and seal ring.

Basic Ordering Number	Number of Outlet Valve	Dimensions, in. (mm)	
		D	E
□□AH-4FNS8	4	5.47 (139.0)	6.81 (173.0)
□□AH-6FNS8	6	8.23 (209.0)	

For a complete ordering number, add a material designator to the basic ordering number.

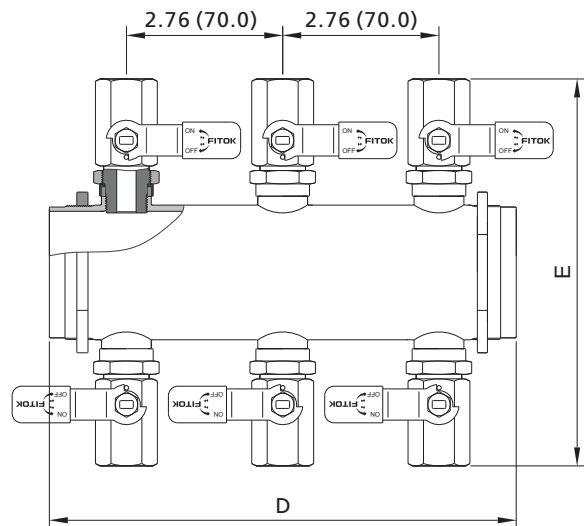

Other Accessories

Accessory	Basic Ordering Number	Description
Inlet Flange	□□AH-AM16	1" Class 150 RF flange
Inlet Thread	□□AH-FNS16	1" Female NPT
Connection Nut	□□AH-LM60	Connects standard modules
O-ring	BN9-932	NBR O-ring

To order accessories other than O-ring, add a material designator (same with the main line) to the basic ordering number. For other inlet flange or thread types, please contact FITOK Group or our authorized distributors.

Ordering Number Description

AHS4 - FNS12Y - 4ML10Y - VFNS8 - U - F2

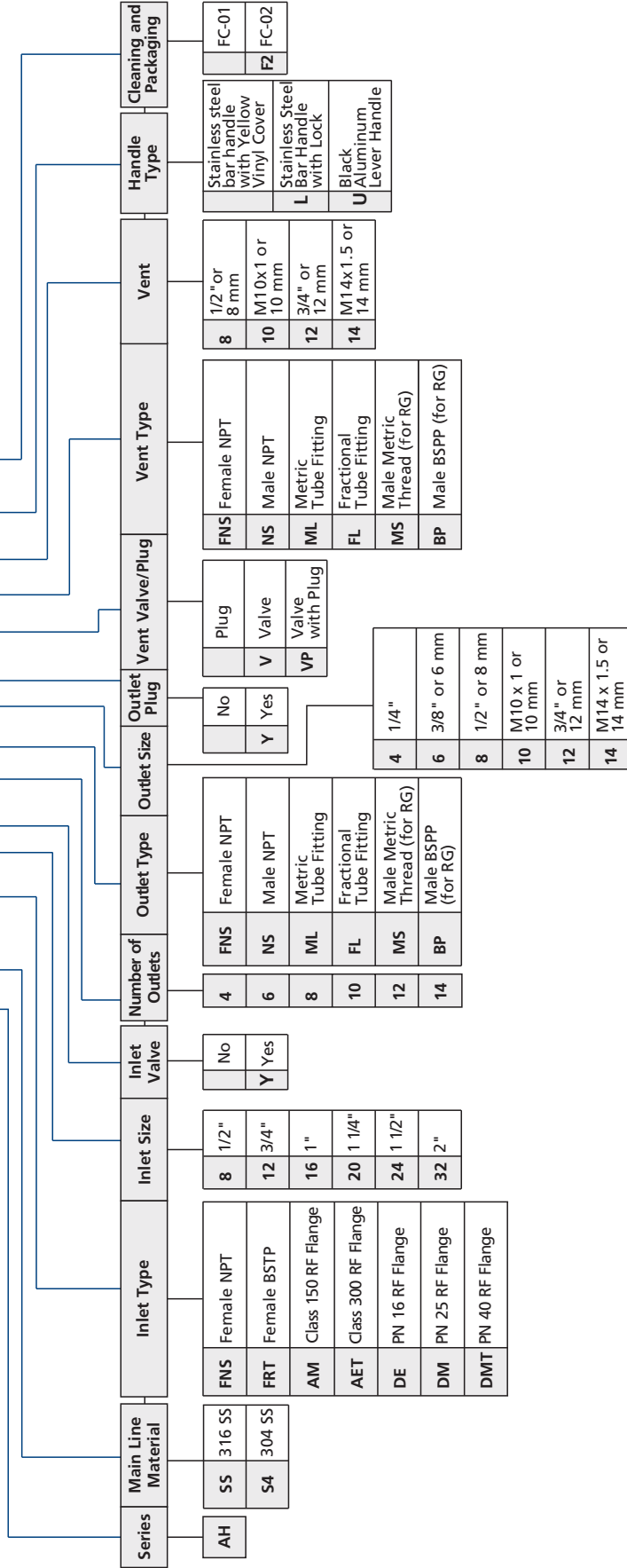

Note:

- "Ordering Number Description" is an reference to understand the combination rules of FITOK part number.
Not all combinations are available.
- Cleaning and Packaging:
FC-01: Standard cleaning and packaging for general industrial procedures.
FC-02: Special cleaning and packaging for wetted system components to ensure compliance with product cleaning requirement as stated in ASTM G93 Level C.

CM Series Distribution Manifolds

Features

- ⦿ Working pressure up to 6000 psig
- ⦿ Working temperature:
 - PTFE packing: -15 to 450°F (-26 to 232°C)
 - Graphite packing: -15 to 1200°F (-26 to 649°C)
- ⦿ One-piece, integral body, compact design
- ⦿ Linear instead of rotary movement of the rising, non-rotating stem minimizes packing abrasion and reduces the friction between the seat and the tip
- ⦿ Upper stem threads cold rolled and lower stem hardened for high strength and smooth operation
- ⦿ Fully back seat sealing at fully open position
- ⦿ Every distribution manifold leak tested at factory with air or Nitrogen at rated working pressure

Major Materials of Construction

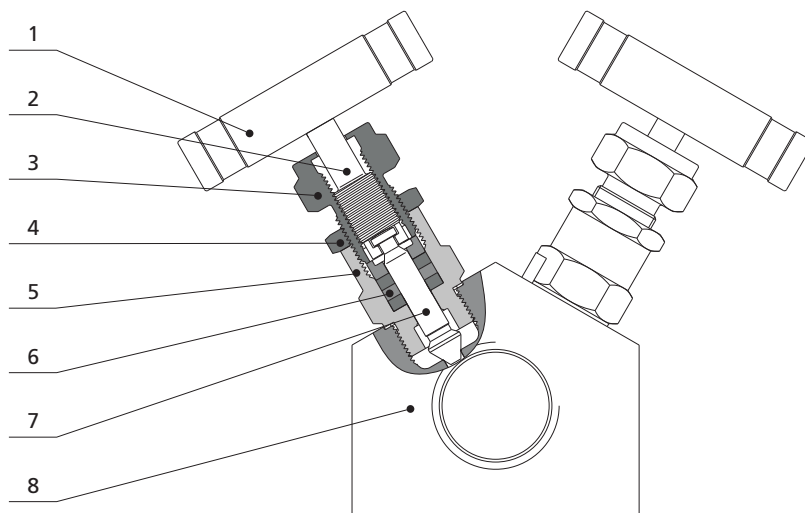

Item	Component	Material	
1	Handle	Anodized aluminum	
2	Upper stem	316 SS	
3	Packing gland	304 SS	
4	Lock nut	Stainless Steel	
5	Bonnet	316 SS	
6	Packing	PTFE	Graphite
7	Lower stem	316 SS	
8	Body	304 SS	316 SS

Standard Connection Types

Port	Connection Type	Specification	Standard
Inlet	Female NPT	3/4"	ASME B1.20.1
Outlet	Female NPT	1/4"	ASME B1.20.1
Vent	Female NPT	1/2"	ASME B1.20.1

Note: The connections listed above are standard. For other connection types, refer to "Ordering Number Description".

Dimensions

Dimensions, in inches (millimeters), are for reference only and are subject to change.

Changes in number of outlets only affect the overall length A, and other dimensions remain the same.

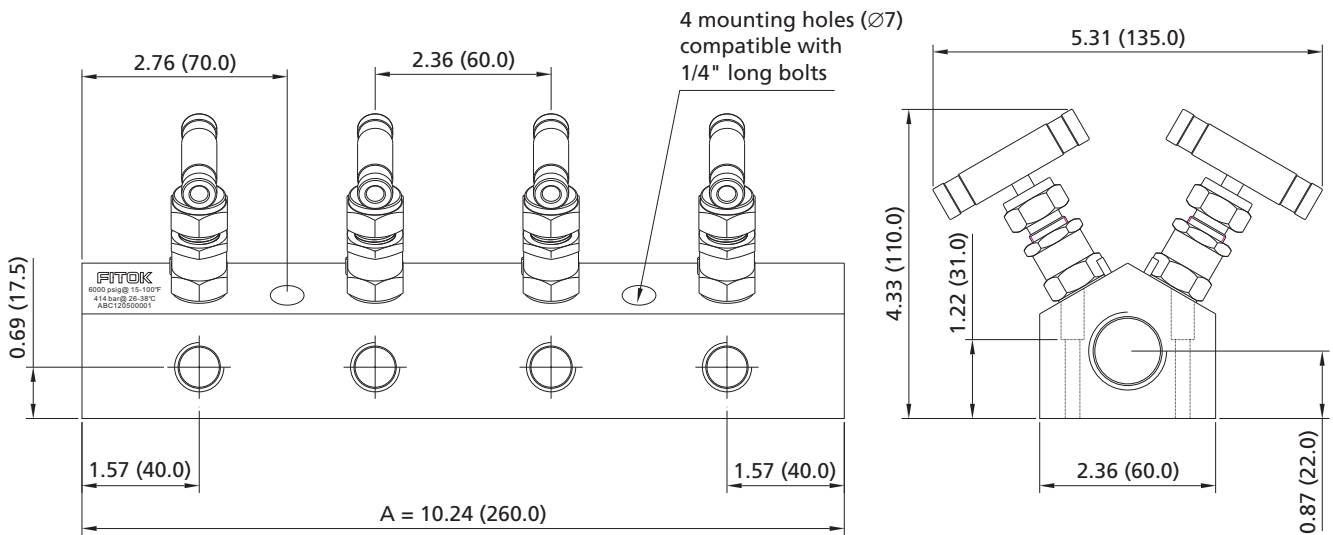

8-outlet manifold shown

Ordering Number Description

CMSS-FNS12-8FNS4Y-VFNS8-GC-SF2

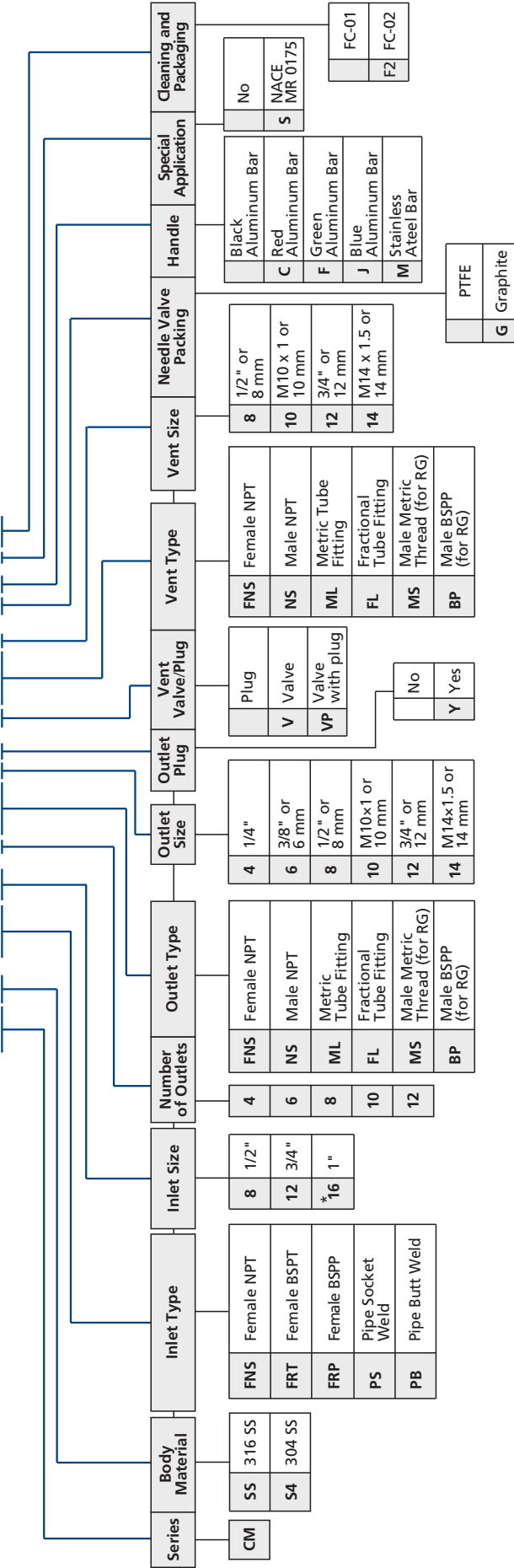

Note:

- "Ordering Number Description" is an reference to understand the combination rules of FITOK part number.
Not all combinations are available.
- Cleaning and Packaging:
FC-01: Standard cleaning and packaging for general industrial procedures.
FC-02: Special cleaning and packaging for wetted system components to ensure compliance with product cleaning requirement as stated in ASTM G93 Level C.
- *Applies to maximum working pressure 3000 psig

Hoses and Connectors

MH, MM, PS, MP, TH and HC Series

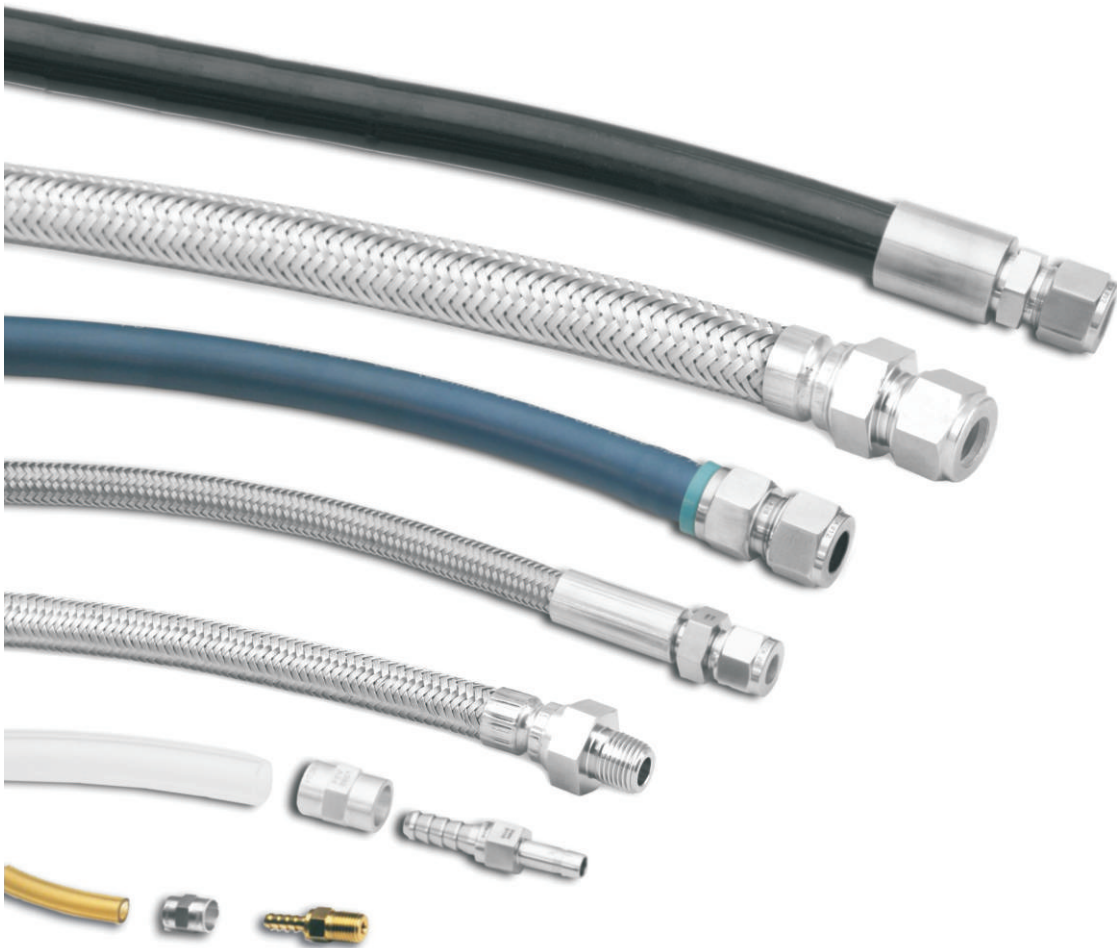

Contents

Metal Flexible Hoses

MH, MM Series



D-04

PTFE-lined, Stainless Steel Braided Hoses

PS Series



D-10

Multipurpose Push-on Hoses

MP Series



D-14

Thermoplastic Hoses

TH Series



D-18

Hose Connectors and Sleeves

HC Series



D-20

Metal Flexible Hoses

MH, MM Series

Features

- Core tube and fitting material: 316 stainless steel
- Overbraid material: 304 stainless steel (316 SS available)
- Vacuum and positive pressure applications
- Working pressure up to: 3100 psig (213 bar)
- Hose size: 1/4" to 2"
- Working temperature: -325°F to 800°F (-200°C to 426°C)
- End connections:
 - 1/4 to 2 thread
 - 1/4" to 2" and 6 mm to 50 mm tube fitting
- Welded fitting-to-hose construction to ensure reliable seal
- Standard and custom length available

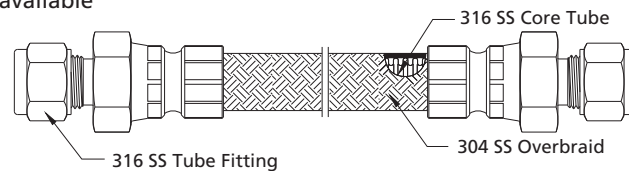

Hose Technical Data (MH Series)

Nominal Hose Size	Inside Diameter	Min. Bend Radius		Temperature Range	Working Pressure at 70°F (20°C)	Burst Pressure at 70°F (20°C)	Hose Series
		Static	Dynamic				
in. (mm)	in. (mm)	in. (mm)	in. (mm)	°F (°C)	psig (bar)	psig (bar)	
1/4 (6.4)	0.28 (7.1)	2.25 (57.2)	10.0 (254)	-325 to 800 (-200 to 426)	3100 (213)	12400 (854)	MH4
3/8 (9.7)	0.42 (10.6)	3.00 (76.2)	12.0 (305)		2000 (137)	8000 (551)	MH6
1/2 (12.7)	0.53 (13.5)	4.50 (114)	16.0 (406)		1800 (124)	7200 (496)	MH8
3/4 (19.0)	0.80 (20.3)	6.00 (152)	17.0 (432)		1500 (103)	6000 (413)	MH12
1 (25.4)	1.03 (26.0)	6.75 (171)	20.0 (508)		1200 (82.6)	4800 (330)	MH16
1 1/4 (31.8)	1.30 (33.0)	8.86 (225)	23.0 (584)		950 (65.4)	3800 (261)	MH20
1 1/2 (38.1)	1.53 (38.9)	11.0 (280)	26.0 (660)		900 (62.0)	3600 (248)	MH24
2 (50.8)	2.05 (52.1)	13.8 (350)	32.0 (813)		500 (34.4)	2000 (137)	MH32

Hose Technical Data (MM Series)

Nominal Hose Size	Inside Diameter	Min. Bend Radius				Temperature Range	Working Pressure at 70°F (20°C)	Burst Pressure at 70°F (20°C)	Hose Series
		Helical Convoluted Core		Annular Convoluted Core					
		Static	Dynamic	Static	Dynamic				
in. (mm)	in. (mm)	in. (mm)	in. (mm)	in. (mm)	in. (mm)	°F (°C)	psig (bar)	psig (bar)	
1/4 (6.4)	0.25 (6.4)	1.38 (35)	8.66 (220)	0.79 (20)	4.33 (110)	-325 to 800 (-200 to 426)	1600 (110)	6400 (440)	MM4
3/8 (9.7)	0.38 (9.5)	2.36 (60)	10.40 (264)	0.98 (25)	5.91 (150)		1470 (101)	6000 (413)	MM6
1/2 (12.7)	0.50 (12.7)	2.95 (75)	11.89 (302)	1.18 (30)	4.88 (124)		1110 (76.4)	4500 (310)	MM8
3/4 (19.0)	0.75 (19.0)	3.54 (90)	13.58 (345)	1.50 (38)	6.65 (169)		860 (59.2)	3500 (241)	MM12
1 (25.4)	1.00 (25.4)	4.13 (105)	15.00 (381)	1.77 (45)	7.68 (195)		680 (46.8)	2680 (184)	MM16
1 1/4 (31.8)	1.25 (31.8)	4.72 (120)	16.22 (412)	/			680 (46.8)	2600 (179)	MM20
1 1/2 (38.1)	1.50 (38.1)	5.51 (140)	16.89 (429)				520 (35.8)	2200 (151)	MM24
2 (50.8)	2.00 (50.8)	6.30 (160)	18.43 (468)				450 (31.0)	1800 (124)	MM32

Testing

Every FITOK metal flexible hose assembly is factory tested with helium to a maximum leak rate of 1×10^{-5} std cm³/s.

Cleaning and Packaging

FITOK metal flexible hose components are cleaned in accordance with FITOK *Standard Cleaning and Packaging Process (FC-01)* for general industrial procedures.

Shorter hoses are packed in cartons with suitable protective material, longer hoses are coiled, bagged and boxed or crated.

Pressure vs. Temperature

MH series

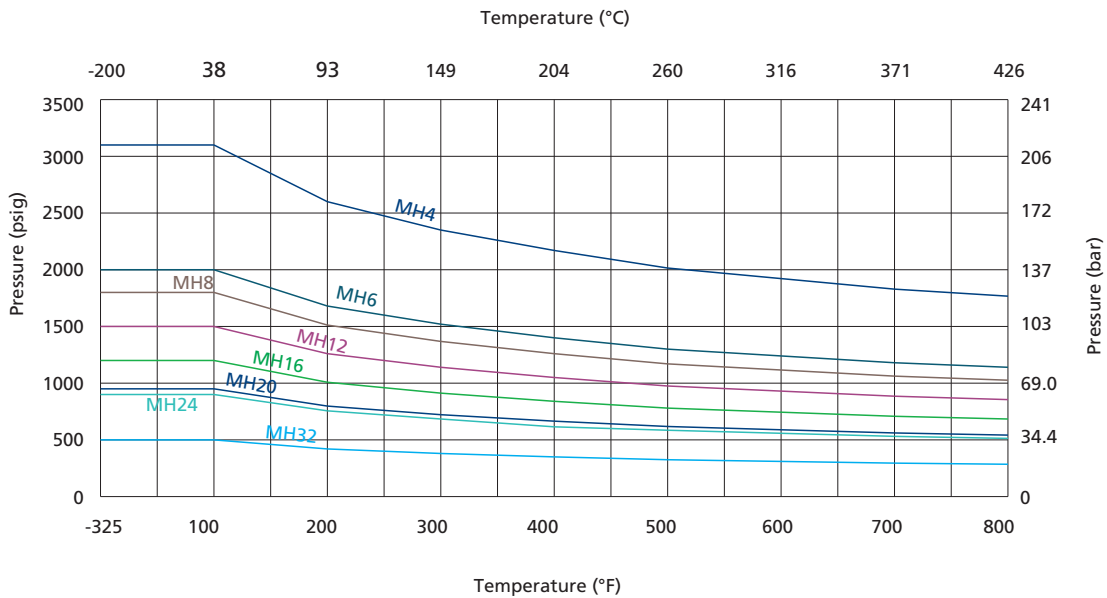

MM series

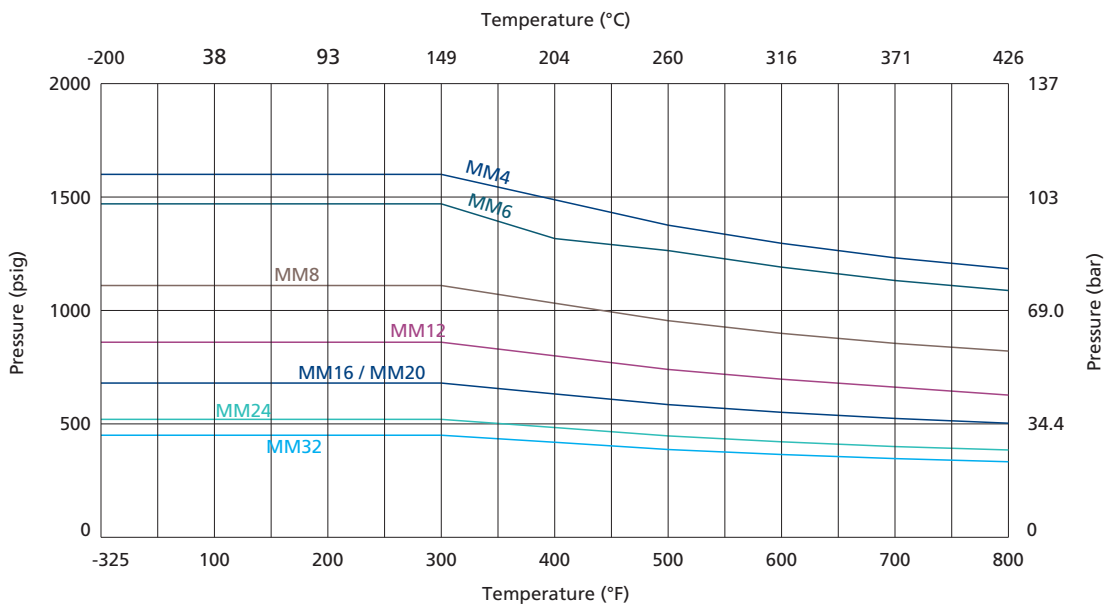

When pulsating, surge, or shock pressures exist, the peak pressure in the system should not exceed 50% of the rated working pressure of the hose.

Standard Assemblies

Tube Fitting to Male NPT End

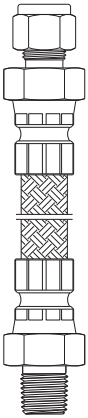

Nominal Hose Size	Tube Fitting Size	NPT Size	Hose Series	Overall Length	Ordering Number	Minimum Inside Diameter	Maximum Outside Dimension
				in. (mm)		in. (mm)	in. (mm)
1/4	1/4	1/4	MH4	12 (305)	SS-MH4-FL4-NS4-F12	0.19 (4.8)	0.94 (23.8)
			MM4	36 (914)	SS-MM4-FL4-NS4-F36	0.19 (4.8)	0.87 (22.0)
3/8	3/8	3/8	MH6	18 (457)	SS-MH6-FL6-NS6-F18	0.28 (7.1)	1.09 (27.7)
			MM6	36 (914)	SS-MM6-FL6-NS6-F36	0.28 (7.1)	1.01 (25.7)
1/2	1/2	1/2	MH8	18 (457)	SS-MH8-FL8-NS8-F18	0.41 (10.4)	1.23 (31.3)
			MM8	48 (1220)	SS-MM8-FL8-NS8-F48	0.41 (10.4)	1.23 (31.3)
3/4	3/4	3/4	MH12	18 (457)	SS-MH12-FL12-NS12-F18	0.66 (16.0)	1.74 (44.2)
			MM12	48 (1220)	SS-MM12-FL12-NS12-F48	0.66 (16.0)	1.59 (40.5)
1	1	1	MH16	24 (610)	SS-MH16-FL16-NS16-F24	0.88 (22.4)	1.82 (46.3)

Tube Fitting End

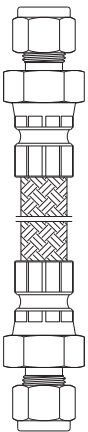

Nominal Hose Size	Tube Fitting Size	Hose Series	Overall Length	Ordering Number	Minimum Inside Diameter	Maximum Outside Dimension
			in. (mm)		in. (mm)	in. (mm)
1/4	1/4	MH4	12 (305)	SS-MH4-FL4-F12	0.19 (4.8)	0.94 (23.8)
		MM4	36 (914)	SS-MM4-FL4-F36	0.19 (4.8)	0.87 (22.0)
3/8	3/8	MH6	18 (457)	SS-MH6-FL6-F18	0.28 (7.1)	1.09 (27.7)
		MM6	36 (914)	SS-MM6-FL6-F36	0.28 (7.1)	1.01 (25.7)
1/2	1/2	MH8	18 (457)	SS-MH8-FL8-F18	0.41 (10.4)	1.23 (31.3)
		MM8	48 (1220)	SS-MM8-FL8-F48	0.41 (10.4)	1.23 (31.3)
3/4	3/4	MH12	18 (457)	SS-MH12-FL12-F18	0.66 (16.0)	1.74 (44.2)
		MM12	48 (1220)	SS-MM12-FL12-F48	0.66 (16.0)	1.59 (40.5)
1	1	MH16	24 (610)	SS-MH16-FL16-F24	0.88 (22.4)	1.82 (46.3)

Tube Adapter End

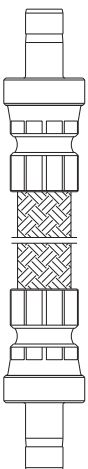

Nominal Hose Size	Tube Adapter Size	Hose Series	Overall Length	Ordering Number	Minimum Inside Diameter	Maximum Outside Dimension
			in. (mm)		in. (mm)	in. (mm)
1/4	1/4	MH4	12 (305)	SS-MH4-FT4-F12	0.16 (4.1)	0.81 (20.6)
		MM4	36 (914)	SS-MM4-FT4-F36	0.16 (4.1)	0.76 (19.2)
3/8	3/8	MH6	12 (305)	SS-MH6-FT6-F12	0.27 (6.9)	1.01 (25.6)
		MM6	36 (914)	SS-MM6-FT6-F36	0.27 (6.9)	0.91 (23.1)

1. All dimensions are for reference only and are subject to change. For dimensions not shown above, please contact FITOK Group or our authorized distributors.
2. Types listed are standard. Other types are available upon request.

End Connections

Tube Adapters

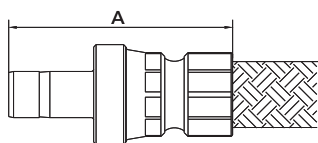

Tube Adapter Size	Nominal Hose Size	End Connection Designator	Dimensions		
			A	Minimum Inside Diameter	Maximum Outside Dimension
in.	in.		in. (mm)		
1/4	1/4	FT4	1.76 (44.7)	0.16 (4.1)	0.81 (20.6)
3/8	3/8	FT6	1.82 (46.2)	0.27 (6.9)	1.01 (25.6)
1/2	1/2	FT8	2.22 (56.4)	0.37 (9.4)	1.23 (31.3)
3/4	3/4	FT12	2.35 (59.7)	0.58 (14.7)	1.53 (38.8)
1	1	FT16	2.69 (68.3)	0.80 (20.3)	1.82 (46.3)
mm	in.	—	mm (in.)		
6	1/4	MT6	44.4 (1.75)	4.1 (0.16)	20.6 (0.81)
10	3/8	MT10	47.0 (1.85)	7.1 (0.28)	25.6 (1.01)
12	1/2	MT12	57.2 (2.25)	8.9 (0.35)	31.3 (1.23)

Tube Fittings

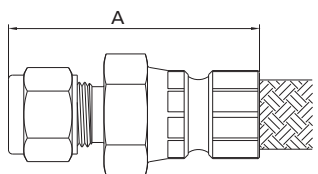

Automatic Weld Style-1 in. and Under

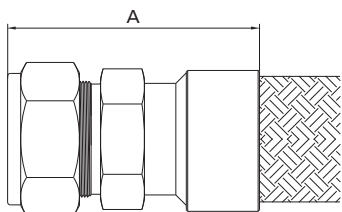

Manual Weld Style-Over 1 in.

Tube Fitting Size	Nominal Hose Size	End Connection Designator	Dimensions		
			A	Minimum Inside Diameter	Maximum Outside Dimension
in.	in.		in. (mm)		
1/4	1/4	FL4	1.94 (49.3)	0.19 (4.8)	0.94 (23.8)
3/8	1/4	FL6	2.00 (50.8)	0.28 (7.1)	0.94 (23.8)
3/8	3/8	FL6	2.02 (51.3)	0.28 (7.1)	1.09 (27.7)
1/2	1/2	FL8	2.24 (56.9)	0.41 (10.4)	1.23 (31.3)
5/8	1/2	FL10	2.27 (57.7)	0.50 (12.7)	1.23 (31.3)
3/4	3/4	FL12	2.35 (59.7)	0.63 (16.0)	1.74 (44.2)
1	1	FL16	2.64 (67.1)	0.88 (22.4)	1.82 (46.3)
1 1/4	1 1/4	FL20	4.04 (103)	1.09 (27.7)	2.23 (58.9)
1 1/2	1 1/2	FL24	4.75 (121)	1.34 (34.0)	2.61 (66.3)
2	2	FL32	5.72 (145)	1.88 (47.8)	3.48 (88.4)
mm	in.	—	mm (in.)		
6	1/4	ML6	62.2 (2.45)	4.8 (0.19)	20.6 (0.81)
8	1/4	ML8	63.2 (2.49)	6.4 (0.25)	20.6 (0.81)
10	3/8	ML10	51.6 (2.03)	7.9 (0.31)	31.3 (1.23)
12	1/2	ML12	56.9 (2.24)	9.7 (0.38)	38.8 (1.53)

Male FR Metal Gasket Face Seal Fittings Swivel

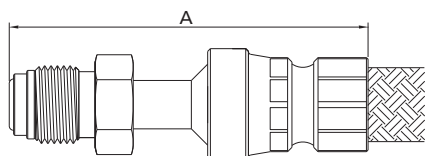

FR Size	Nominal Hose Size	End Connection Designator	Dimensions		
			A	Minimum Inside Diameter	Maximum Outside Dimension
in.	in.		in. (mm)		
1/4	1/4	SFR4	2.60 (66.0)	0.18 (4.6)	0.81 (20.6)
1/2	1/2	SFR8	2.83 (71.9)	0.40 (10.2)	1.23 (31.3)
3/4	3/4	SFR12	4.19 (106)	0.65 (16.5)	1.52 (38.7)
1	1	SFR16	4.80 (122)	0.87 (22.1)	1.53 (38.8)

End Connections

Female FR Metal Gasket Face Seal Fittings Swivel

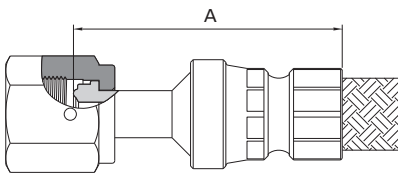

FR Size	Nominal Hose Size	End Connection Designator	Dimensions		
			A	Minimum Inside Diameter	Maximum Outside Dimension
in.	in.		in. (mm)		
1/4	1/4	SFFR4	2.00 (50.8)	0.18 (4.6)	0.87 (22.1)
1/2	1/2	SFFR8	2.16 (54.9)	0.40 (10.2)	1.23 (31.3)
3/4	3/4	SFFR12	4.19 (106)	0.65 (16.5)	1.74 (44.2)
1	1	SFFR16	4.80 (122)	0.87 (22.1)	2.03 (51.6)

Female FO O-Ring Face Seal Fittings Swivel

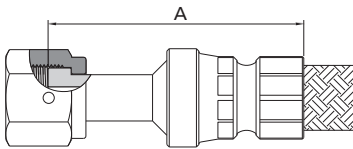

FO Size	Nominal Hose Size	End Connection Designator	Dimensions		
			A	Minimum Inside Diameter	Maximum Outside Dimension
in.	in.		in. (mm)		
1/4	1/4	SFFO4	2.11 (53.6)	0.18 (4.6)	0.81 (20.6)
1/2	1/2	SFFO8	2.14 (54.4)	0.40 (10.2)	1.23 (31.3)

SAE 37° (JIC) Female Swivel

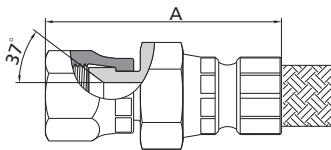

Swivel Size	Nominal Hose Size	End Connection Designator	Dimensions		
			A	Minimum Inside Diameter	Maximum Outside Dimension
in.	in.		in. (mm)		
1/4	1/4	SAN4	1.87 (47.5)	0.17 (4.3)	0.81 (20.6)
3/8	3/8	SAN6	1.98 (50.3)	0.28 (7.1)	1.01 (25.6)
1/2	1/2	SAN8	2.25 (57.2)	0.42 (10.7)	1.23 (31.3)

Female Pipe Threads, NPT

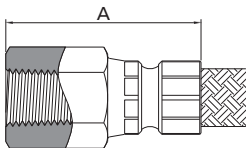

NPT Size	Nominal Hose Size	End Connection Designator	Dimensions		
			A	Minimum Inside Diameter	Maximum Outside Dimension
in.	in.		in. (mm)		
1/4	1/4	FNS4	1.81 (46.0)	0.28 (7.1)	0.94 (23.9)
3/8	3/8	FNS6	1.87 (47.5)	0.38 (9.7)	1.09 (27.7)
1/2	1/2	FNS8	2.18 (55.4)	0.47 (11.9)	1.23 (31.3)
3/4	3/4	FNS12	2.21 (56.1)	0.72 (18.3)	1.74 (44.2)

Male Pipe Threads, NPT

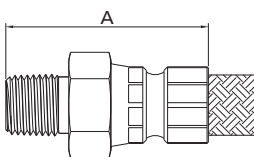

Automatic Weld Style-1 in. and Under

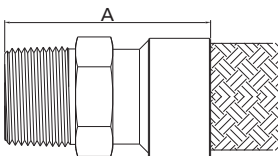

Manual Weld Style-Over 1 in.

NPT Size	Nominal Hose Size	End Connection Designator	Dimensions		
			A	Minimum Inside Diameter	Maximum Outside Dimension
in.	in.		in. (mm)		
1/4	1/4	NS4	1.80 (45.7)	0.28 (7.1)	0.94 (23.9)
1/4	3/8	NS4	1.81 (46.0)	0.28 (7.1)	1.09 (27.7)
3/8	3/8	NS6	1.81 (46.0)	0.38 (9.7)	1.09 (27.7)
1/2	1/4	NS8	1.99 (50.6)	0.47 (11.9)	1.02 (25.8)
1/2	1/2	NS8	2.15 (54.6)	0.47 (11.9)	1.23 (31.3)
3/4	3/4	NS12	2.22 (56.4)	0.63 (16.0)	1.74 (44.2)
1	1	NS16	2.54 (64.5)	0.88 (22.4)	1.82 (46.3)
1 1/4	1 1/4	NS20	3.06 (77.7)	1.09 (27.7)	2.03 (51.6)
1 1/2	1 1/2	NS24	3.72 (94.5)	1.34 (34.0)	2.47 (62.6)
2	2	NS32	4.19 (106)	1.81 (46.0)	3.19 (81.0)

Ordering Number Description

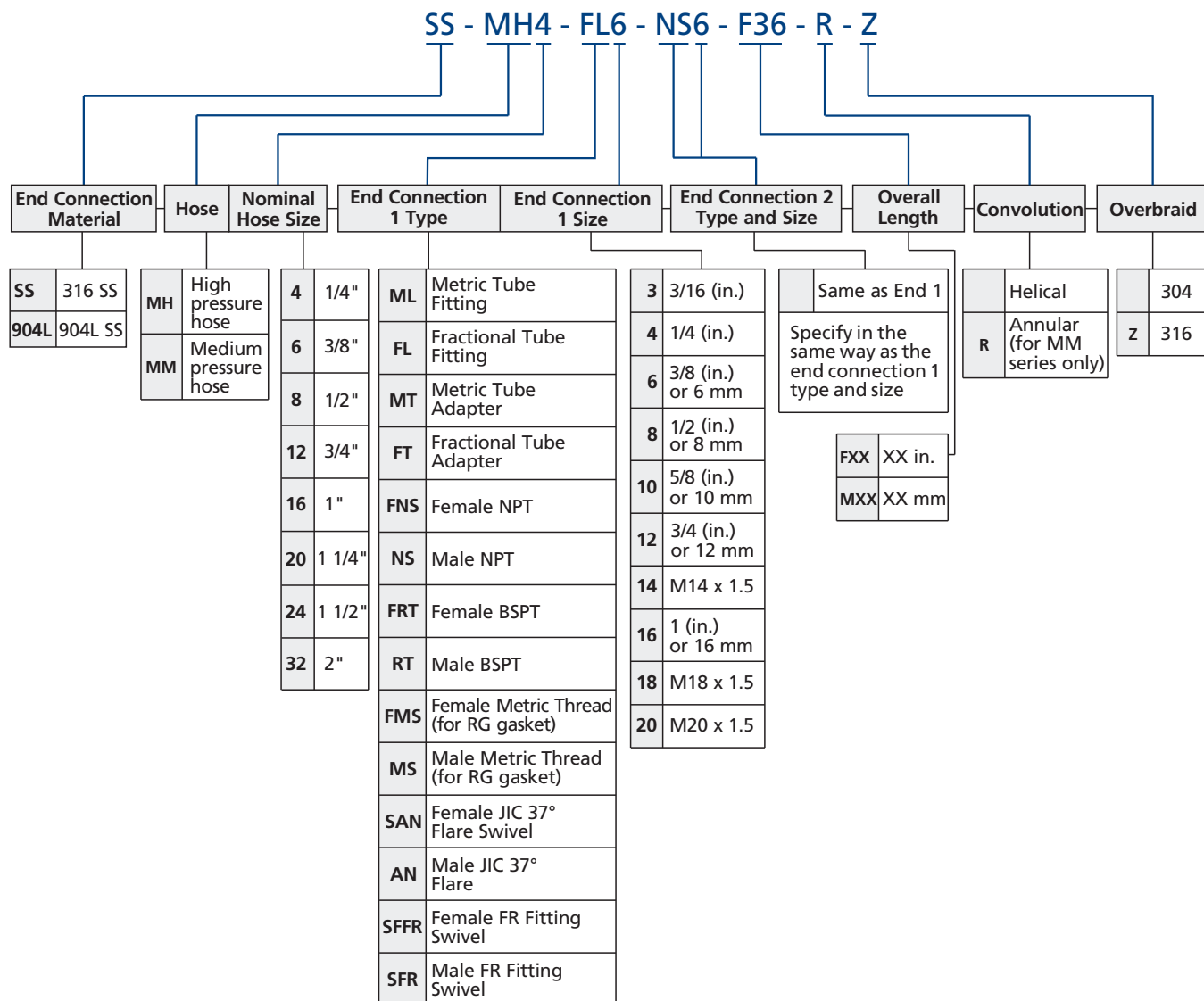

Example: SS-MH4-FT6-M710

SS: End connection material is 316 stainless steel.

MH4: MH series, hose size is 1/4".

FT6: End connection 1 is 3/8" tube adapter.

End connection 2 is 3/8" tube adapter.

M710: Overall length is 710 mm.

Note: "Ordering Number Description" is a reference to understand the combination rules of FITOK product part number. Not all combinations are available.

End 1 and end 2 follow the orders and regulations below:

1. Metric Double Ferrules - Fractional Double Ferrules - Metric Tube Adapters - Fractional Tube Adapters - NPT Threads - BSPT Threads - BSPP Threads -SAE/MS Parallel Threads - 37° Flare - Others
2. Put the sizes from the biggest down to the smallest if they are of the same type.
3. Put the female before male if they are of the same type and size.

PTFE-lined, Stainless Steel Braided Hoses

PS Series

Features

- ⦿ Lightweight construction for easy handling and installation
- ⦿ Core tube material: smooth virgin PTFE
- ⦿ Overbraid material: 304 stainless steel
- ⦿ Working pressure up to: 3000 psig (207 bar)
- ⦿ Hose size: 1/4" to 1"
- ⦿ Working temperature: -65°F to 400°F (-53°C to 204°C)
- ⦿ Standard and custom length available

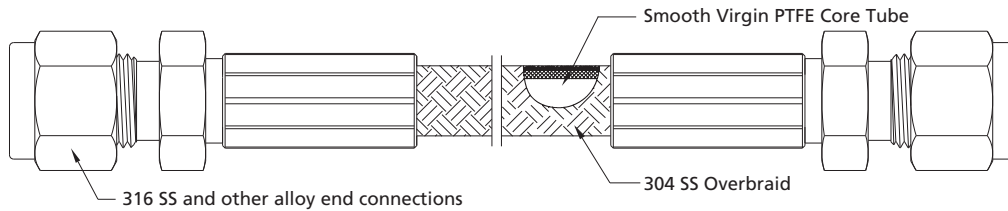

Hose Technical Data

Nominal Hose Size	Inside Diameter	Min. Inside Bend Radius		Temperature Range	Working Pressure at 70°F (20°C)	Burst Pressure at 70°F (20°C)
		Static	Dynamic			
in. (mm)	in. (mm)	in. (mm)	in. (mm)	°F (°C)	psig (bar)	psig (bar)
1/4 (6.4)	0.19 (4.8)	1.5 (38.1)	2.0 (50.8)	-65 to 400 (-53 to 204)	3000 (206)	12000 (826)
3/8 (9.5)	0.31 (7.9)	3.5 (88.9)	5.0 (127)		2500 (172)	10000 (690)
1/2 (12.7)	0.41 (10.3)	4.5 (114)	6.0 (152)		2000 (137)	8000 (551)
3/4 (19.0)	0.63 (15.9)	6.0 (152)	7.5 (190)		1500 (103)	6000 (413)
1 (25.4)	0.88 (22.2)	9.0 (229)	11.3 (287)		1000 (68)	4000 (275)

Hoses
Quick-connects

Pressure vs. Temperature

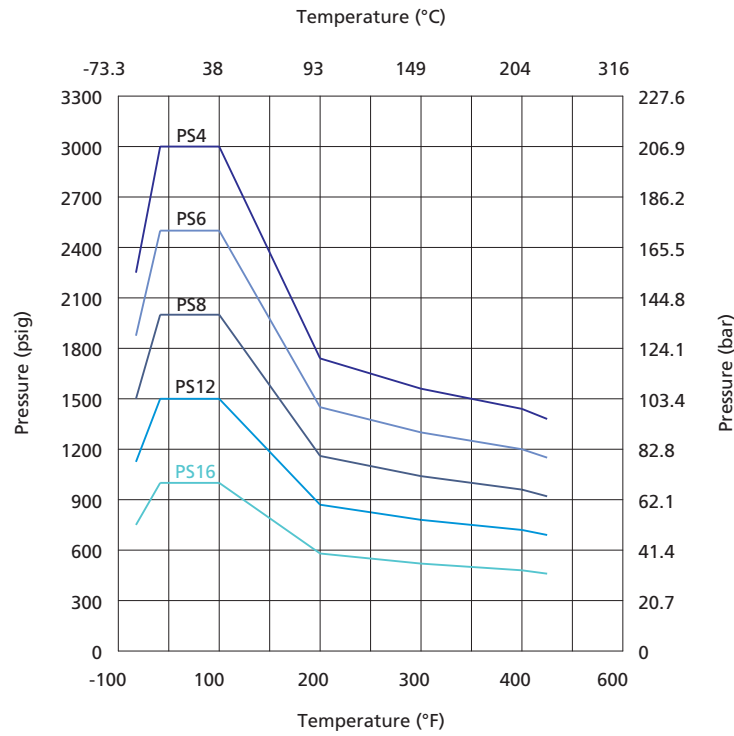

Testing

Every FITOK PTFE-lined hose assembly is factory tested with pure water at 1.5 times the maximum working pressure.

Cleaning and Packaging

FITOK PTFE-lined hose components are cleaned in accordance with FITOK *Standard Cleaning and Packaging Process (FC-01)* for general industrial procedures.

Shorter hoses are packed in cartons with suitable protective material, longer hoses are coiled, bagged and boxed or crated.

PTFE-lined Hose Standard Assemblies

Tube Adapters

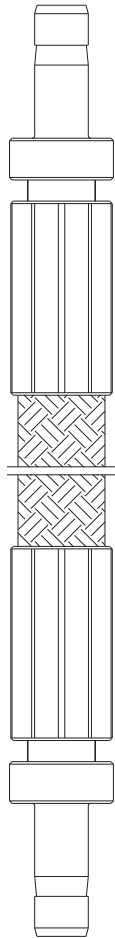

Nominal Hose Size	Tube Adapter Size	Overall Length	Ordering Number	Minimum Inside Diameter	Maximum Outside Dimension
in.	in.	in. (mm)		in. (mm)	in. (mm)
1/4	1/4	6.0 (153)	SS-PS4-FT4-F6	0.16 (4.1)	0.54 (13.7)
		12.0 (305)	SS-PS4-FT4-F12		
		18.0 (458)	SS-PS4-FT4-F18		
		24.0 (610)	SS-PS4-FT4-F24		
		36.0 (915)	SS-PS4-FT4-F36		
		48.0 (1220)	SS-PS4-FT4-F48		
		60.0 (1530)	SS-PS4-FT4-F60		
		72.0 (1829)	SS-PS4-FT4-F72		
		120.0 (3050)	SS-PS4-FT4-F120		
3/8	3/8	12.0 (305)	SS-PS6-FT6-F12	0.27 (6.9)	0.73 (18.5)
		18.0 (458)	SS-PS6-FT6-F18		
		24.0 (610)	SS-PS6-FT6-F24		
		36.0 (915)	SS-PS6-FT6-F36		
		48.0 (1220)	SS-PS6-FT6-F48		
		60.0 (1530)	SS-PS6-FT6-F60		
		72.0 (1829)	SS-PS6-FT6-F72		
		96.0 (2439)	SS-PS6-FT6-F96		
		120.0 (3050)	SS-PS6-FT6-F120		
1/2	1/2	12.0 (305)	SS-PS8-FT8-F12	0.36 (9.1)	0.86 (21.8)
		24.0 (610)	SS-PS8-FT8-F24		
		36.0 (915)	SS-PS8-FT8-F36		
		48.0 (1220)	SS-PS8-FT8-F48		
		60.0 (1530)	SS-PS8-FT8-F60		
		72.0 (1829)	SS-PS8-FT8-F72		
3/4	3/4	24.0 (610)	SS-PS12-FT12-F24	0.53 (13.5)	1.04 (26.4)
		36.0 (915)	SS-PS12-FT12-F36		
1	1	36.0 (915)	SS-PS16-FT16-F36	0.80 (20.3)	1.36 (34.5)
		48.0 (1220)	SS-PS16-FT16-F48		
in.	mm	in. (mm)	—	in. (mm)	in. (mm)
1/4	6	12.0 (305)	SS-PS4-MT6-F12	0.16 (4.1)	0.54 (13.7)
		24.0 (610)	SS-PS4-MT6-F24		
		36.0 (915)	SS-PS4-MT6-F36		
1/2	12	24.0 (610)	SS-PS8-MT12-F24	0.33 (8.4)	0.86 (21.8)
		36.0 (915)	SS-PS8-MT12-F36		

1. All dimensions are for reference only and are subject to change. For dimensions not shown above, please contact FITOK Group or our authorized distributors.
2. Sizes and types listed are standard. Other sizes and types are available on request.

Ordering Number Description

SS – PS4 – FL6 – FT6 – M1000 – SPF2

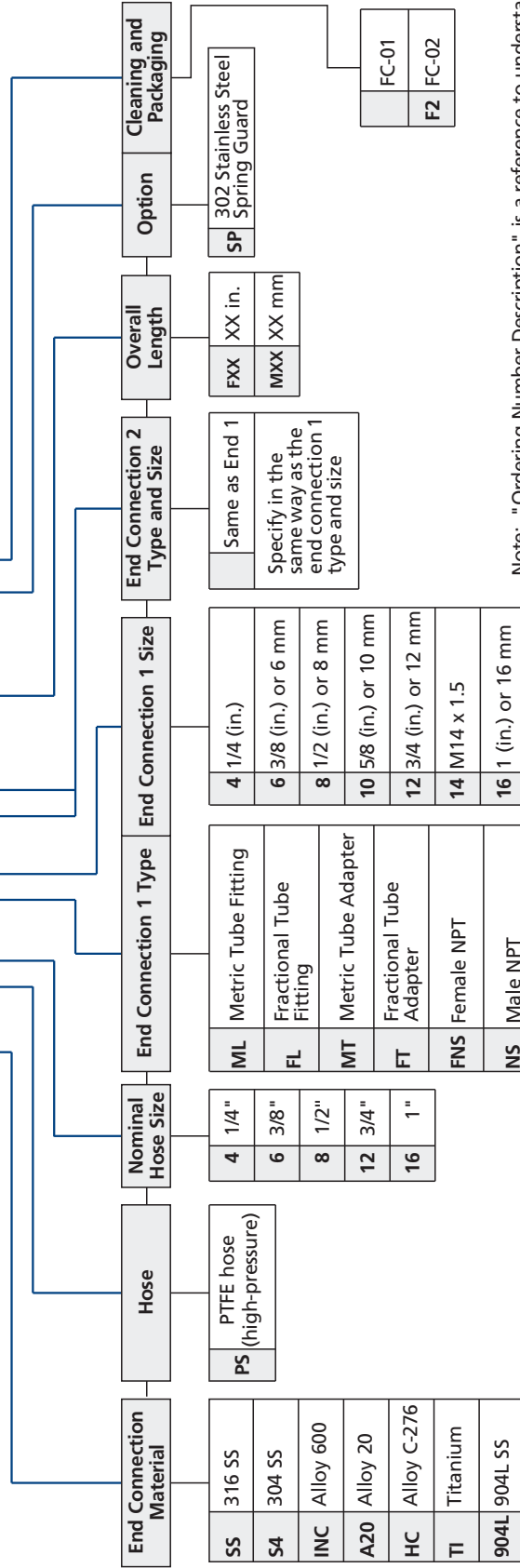

Note: "Ordering Number Description" is a reference to understand the combination rules of FITOK product part number. Not all combinations are available.

Example: **SS-PS4-SAN4-M500**

SS: End connection material is 316 stainless steel.

PS4: PS series, hose inside diameter is 3/16".

SAN4: End connection 1 is 1/4" female JIC 37° flare swivel.

End connection 2 is 1/4" female JIC 37° flare swivel.

M500: Overall length is 500 mm.

- Options and accessories do not change hose technical data. Hose operating parameters must be considered when selecting a cover.
- 302 stainless steel spring guard covers entire hose to protect against kinking and abrasion.

End 1 and end 2 follow the orders and regulations below:

- Metric Double Ferrules - Fractional Double Ferrules - Metric Tube Adapters - Fractional Tube Adapters - NPT Threads - BSPP Threads - BSPP Threads - SAE/IMS Parallel Threads - 37° Flare - Others
- Put the sizes from the biggest down to the smallest if they are of the same type.
- Put the female before male if they are of the same type and size.

Multipurpose Push-on Hoses

MP Series

Features

- ⦿ Cover: weatherproof, abrasion withstanding and oil-resistant synthetic rubber
- ⦿ Reinforcement: single-braid high-strength synthetic fiber woven for maximum strength and end connection retention
- ⦿ Core tube: highly oil-resistant rubber
- ⦿ Hose colors: blue, black, green, gray, red and yellow
- ⦿ Working pressure up to: 300 psig (20.7 bar)
- ⦿ Hose size: 1/4" to 3/4"
- ⦿ Working temperature: -40°F to 200°F (-40°C to 93°C)
- ⦿ End connection materials: stainless steel and brass
- ⦿ End connections reusable
- ⦿ Custom length available

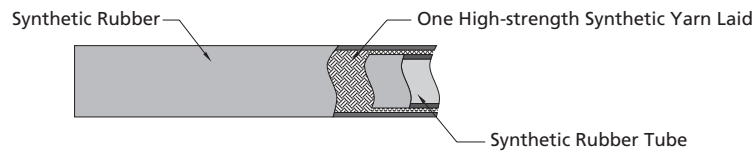

Hose Technical Data

Nominal Hose Size	Inside Diameter	Min. Inside Bend Radius	Temperature Range	Working Pressure at -40 to 70°F (-40 to 20°C)	Min. Burst Pressure at 70°F (20°C)
in. (mm)	in. (mm)	in. (mm)	°F(°C)	psig (bar)	psig (bar)
1/4 (6.4)	0.26 (6.6)	2.50 (63.5)	-40 to 200 (-40 to 93)	300 (20.6)	1200 (82.7)
3/8 (9.5)	0.39 (9.9)	3.00 (76.2)			
1/2 (12.7)	0.50 (12.7)	5.00 (127)			
3/4 (19.0)	0.76 (19.3)	7.00 (178)			

Pressure vs. Temperature

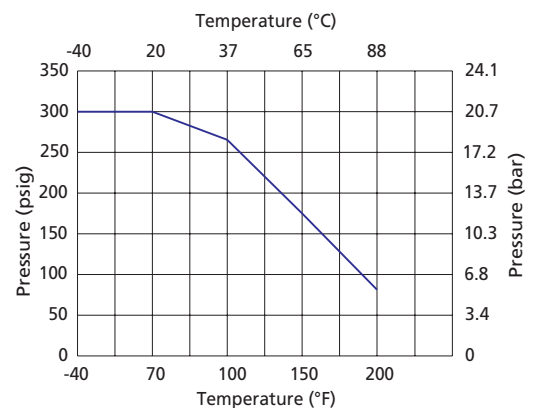

Testing

Every FITOK multipurpose push-on hose assembly is factory tested with pure water at 1.5 times the maximum working pressure.

Cleaning and Packaging

FITOK multipurpose push-on hose components are cleaned in accordance with FITOK *Standard Cleaning and Packaging Process (FC-01)* for general industrial procedures.

Shorter hoses are packed in cartons with suitable protective material, longer hoses are coiled, bagged and boxed or crated.

Multipurpose Push-on Hose End Connections

Tube Fittings

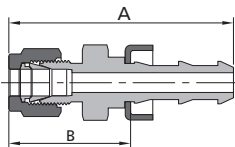

Nominal Hose Size	Tube Fitting Size	Basic Ordering Number	Dimensions, in. (mm)			
			A	B	Minimum Inside Diameter	Maximum Outside Dimension
in.	in.					
1/4	1/4	-MP4-FL4	1.97 (50.0)	1.21 (30.7)	0.16 (4.1)	0.67 (17.0)
3/8	3/8	-MP6-FL6	2.11 (53.6)	1.24 (31.5)	0.27 (6.9)	0.87 (22.1)
1/2	1/2	-MP8-FL8	2.47 (62.7)	1.42 (36.1)	0.37 (9.5)	1.02 (25.8)

Tube Adapters

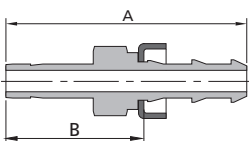

Nominal Hose Size	Tube Adapter Size	Basic Ordering Number	Dimensions, in. (mm)			
			A	B	Minimum Inside Diameter	Maximum Outside Dimension
in.	in.					
1/4	1/4	-MP4-FT4	1.93 (49.0)	1.17 (29.7)	0.15 (3.8)	0.67 (17.0)
3/8	3/8	-MP6-FT6	2.03 (51.6)	1.16 (29.5)	0.24 (6.1)	0.83 (21.1)
1/2	1/2	-MP8-FT8	2.47 (62.7)	1.42 (36.1)	0.34 (8.7)	0.98 (24.9)
3/4	3/4	-MP12-FT12	3.14 (79.8)	1.48 (37.6)	0.57 (14.5)	1.23 (31.3)
in.	mm	—	mm(in.)			
1/4	6	-MP4-MT6	49.0 (1.93)	29.7 (1.17)	3.8 (0.15)	17.0 (0.67)
1/4	8	-MP4-MT8	48.8 (1.92)	29.5 (1.16)	4.1 (0.16)	17.0 (0.67)
3/8	8	-MP6-MT8	52.1 (2.05)	30.0 (1.18)	5.6 (0.22)	21.1 (0.83)
3/8	10	-MP6-MT10	51.6 (2.03)	29.5 (1.16)	6.9 (0.27)	21.1 (0.83)
1/2	12	-MP8-MT12	62.7 (2.47)	36.1 (1.42)	8.1 (0.32)	24.9 (0.98)
3/4	18	-MP12-MT18	79.8 (3.14)	37.3 (1.47)	8.6 (0.34)	31.3 (1.23)

Male NPT

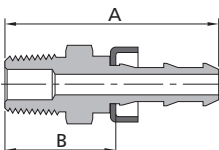

Nominal Hose Size	NPT Size	Basic Ordering Number	Dimensions, in. (mm)			
			A	B	Minimum Inside Diameter	Maximum Outside Dimension
in.						
1/4	1/4	-MP4-NS4	1.68 (42.7)	0.92 (23.4)	0.16 (4.1)	0.67 (17.0)
3/8	1/4	-MP6-NS4	1.80 (45.7)	0.93 (23.6)	0.27 (6.9)	0.83 (21.1)
3/8	3/8	-MP6-NS6	1.80 (45.7)	0.93 (23.6)	0.27 (6.9)	0.83 (21.1)
1/2	1/2	-MP8-NS8	2.19 (55.6)	1.14 (29.0)	0.37 (9.5)	1.02 (25.9)
3/4	3/4	-MP12-NS12	2.81 (71.4)	1.14 (29.0)	0.61 (15.6)	1.31 (33.3)

Male BSPT

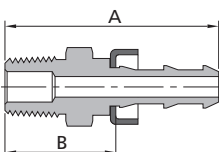

Nominal Hose Size	BSPT Size	Basic Ordering Number	Dimensions, in. (mm)			
			A	B	Minimum Inside Diameter	Maximum Outside Dimension
in.						
1/4	1/4	-MP4-RT4	1.68 (42.7)	0.92 (23.4)	0.16 (4.1)	0.67 (17.0)
3/8	1/4	-MP6-RT4	1.80 (45.7)	0.93 (23.6)	0.27 (6.9)	0.83 (21.1)
3/8	3/8	-MP6-RT6	1.80 (45.7)	0.93 (23.6)	0.27 (6.9)	0.83 (21.1)
1/2	1/2	-MP8-RT8	2.19 (55.6)	1.14 (29.0)	0.37 (9.5)	1.02 (25.9)
3/4	3/4	-MP12-RT12	2.81 (71.4)	1.14 (29.0)	0.61 (15.6)	1.31 (33.3)

Unions

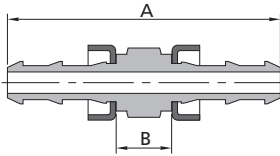

Nominal Hose Size	Basic Ordering Number	Dimensions, in. (mm)			
		A	B	Minimum Inside Diameter	Maximum Outside Dimension
in.					
1/4	-MP4-4	2.07 (52.6)	0.43 (11.4)	0.16 (4.1)	0.67 (17.0)
3/8	-MP6-6	2.25 (57.2)	0.40 (12)	0.27 (6.9)	0.83 (21.1)
1/2	-MP8-8	2.61 (69.8)	0.40 (14)	0.37 (9.5)	0.96 (24.5)
3/4	-MP12-12	3.85 (97.8)	0.47 (12.0)	0.61 (15.6)	1.23 (31.3)

Hose Ordering Number Description

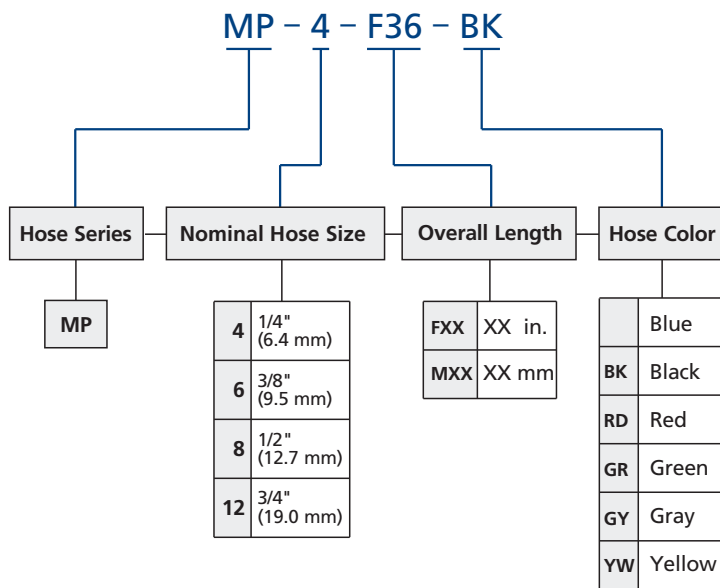

Example: **MP-8-F60-BK**

MP: Hose series

8: Hose size is 1/2".

F60: Overall length is 60".

BK: Hose color is black.

Note: "Ordering Number Description" is a reference to understand the combination rules of FITOK product part number. Not all combinations are available.

Multipurpose Push-On Hose Custom Assemblies



Ordering Number Description

SS – MP4 – FL4 – FT4 – F36 – BK

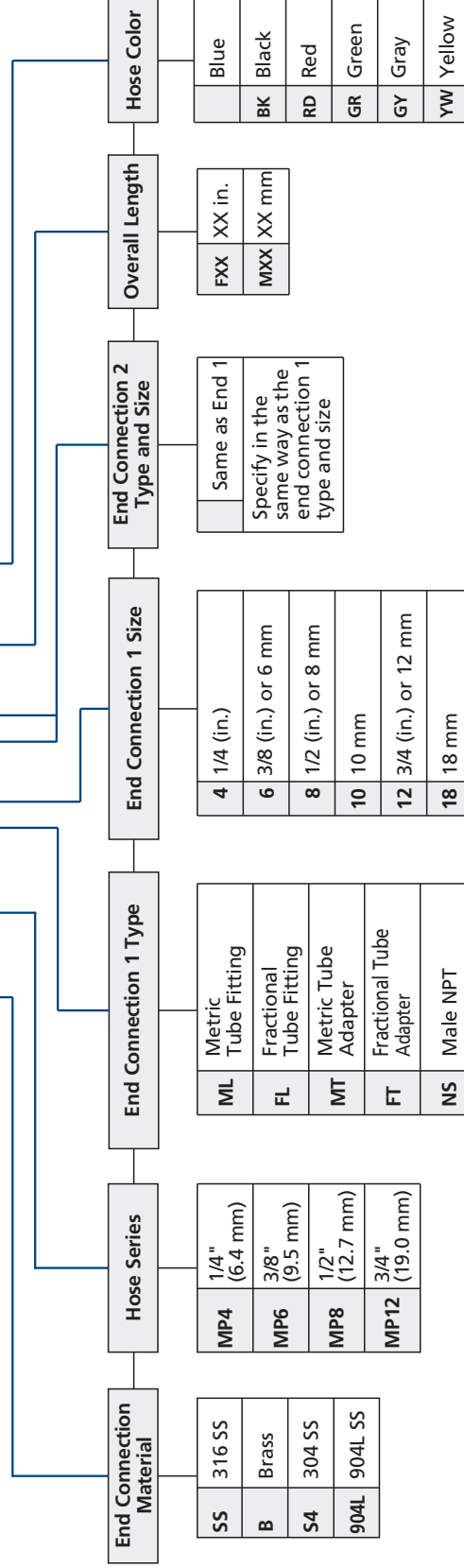

Example: **SS-MP4-FT4-F28-BK**

SS: End connection material is 316 stainless steel.

MP4: MP series, hose size is 1/4" .

FT4: End connection 1 is 1/4" tube adapter.

End connection 2 is 1/4" tube adapter.

F28: Overall length is 28" .

BK : Hose color is black.

Note: "Ordering Number Description" is a reference to understand the combination rules of FITOK product part number. Not all combinations are available.

End 1 and end 2 follow the orders and regulations below:

1. Metric Double Ferrules - Fractional Double Ferrules - Metric Tube Adapters - Fractional Tube Adapters - NPT Threads - BSPT Threads - SAE/IMS Parallel Threads - 37° Flare - Others
2. Put the sizes from the biggest down to the smallest if they are of the same type.
3. Put the female before male if they are of the same type and size.

Thermoplastic Hoses

TH Series

Features

- Polyurethane cover: resists oil, weather and abrasion
- Reinforcement: double-braid high-strength synthetic fiber
- Core tube: nylon
- Working pressure up to: 5000 psig (345 bar)
- Hose size: 3/16" to 1"
- Working temperature: -40°F to 200°F (-40°C to 93°C)
- End connections: 1/4 to 1 thread, 1/4" to 1" and 6 mm to 22 mm tube fitting
- End connection materials: stainless steel, brass and carbon steel
- Custom length available

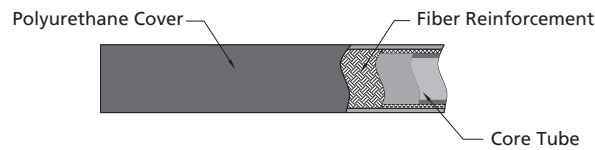

Technical Data

Thermoplastic Hydraulic Hose (SAE 100R7)

Nominal Hose Size	Hose Series	Min. Inside Bend Radius	Inside Diameter	Temperature Range	Working Pressure at 70°F (20°C)	Min. Burst Pressure at 70°F (20°C)	Specification
in. (mm)		in. (mm)	in. (mm)	°F (°C)	psig (bar)	psig (bar)	
3/16 (4.8)	TH3	1.58 (40)	0.19 (4.8)	-40 to 200 (-40 to 93)	3000 (207)	12000 (828)	SAE J517 100R7
1/4 (6.4)	TH4	1.97 (50)	0.25 (6.4)		2750 (189)	11000 (758)	
5/16 (8.0)	TH5	2.36 (60)	0.31 (7.9)		2500 (173)	10000 (690)	
3/8 (9.6)	TH6	2.95 (75)	0.38 (9.8)		2250 (155)	9000 (620)	
1/2 (12.7)	TH8	3.74 (95)	0.50 (12.7)		2000 (137)	8000 (551)	

Thermoplastic Hydraulic Hose (SAE 100R8)

Nominal Hose Size	Hose Series	Min. Inside Bend Radius	Inside Diameter	Temperature Range	Working Pressure at 70°F (20°C)	Min. Burst Pressure at 70°F (20°C)	Specification
in. (mm)		in. (mm)	in. (mm)	°F (°C)	psig (bar)	psig (bar)	
3/16 (4.8)	TH3	2.00 (50.8)	0.19 (4.8)	-40 to 200 (-40 to 93)	5000 (344)	20000 (1378)	SAE J517 100R8
1/4 (6.4)	TH4	2.00 (50.8)	0.25 (6.4)		5000 (344)	20000 (1378)	
3/8 (9.6)	TH6	2.50 (63.5)	0.38 (9.8)		4000 (275)	16000 (1102)	
1/2 (12.7)	TH8	4.00 (102)	0.50 (12.7)		3500 (241)	14000 (964)	
3/4 (19.0)	TH12	6.50 (165)	0.75 (19.0)		2250 (155)	9000 (620)	
1 (25.4)	TH16	10.0 (254)	1.00 (25.4)		2000 (137)	8000 (551)	

Testing

Every FITOK thermoplastic hose assembly is factory tested with pure water at 1.5 times the maximum working pressure.

Cleaning and Packaging

FITOK thermoplastic hose components are cleaned in accordance with FITOK *Standard Cleaning and Packaging Process (FC-01)* for general industrial procedures.

Shorter hoses are packed in cartons with suitable protective material, longer hoses are coiled, bagged and boxed or crated.

Thermoplastic Hose Assemblies



Ordering Number Description

SS – TH4 – FL4 – SAN4 – M1000 – R7

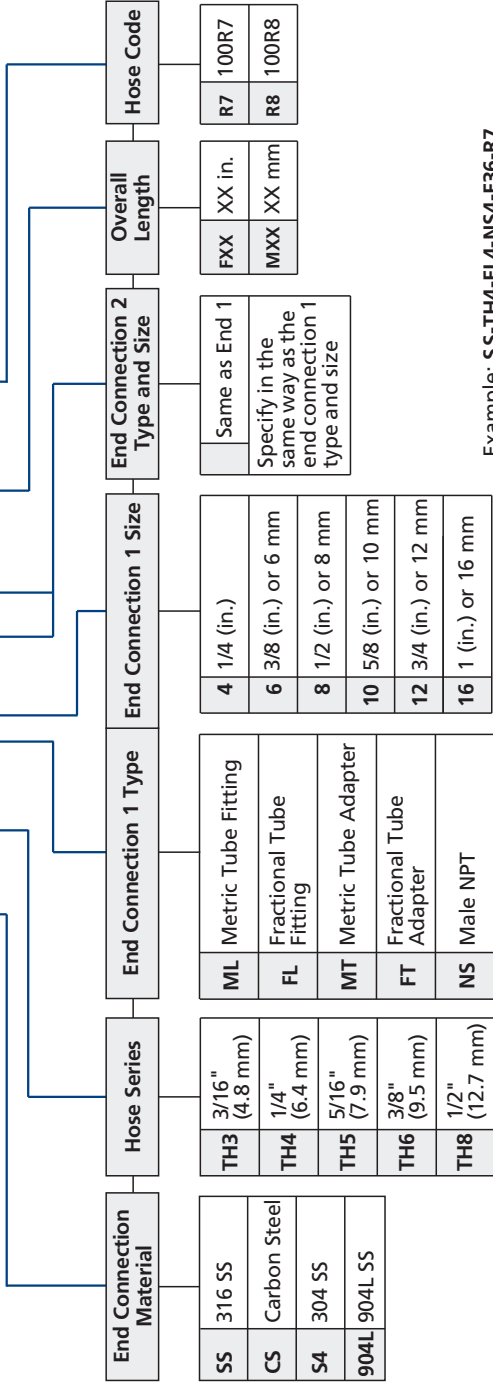

Example: **SS-TH4-FL4-NS4-F36-R7**
SS: End connection material is 316 stainless steel.
TH4: TH series, hose size is 1/4"
FL4: End connection 1 is 1/4" tube fitting.
NS4 : End connection 2 is 1/4 male NPT.
F36 : Overall length is 36"
R7 : SAE J517 100R7.

End 1 and end 2 follow the orders and regulations below:

1. Metric Double Ferrules - Fractional Double Ferrules - Metric Tube Adapters - Fractional Tube Adapters - NPT Threads - BSPT Threads - BSPP Threads - SAE/MS Parallel Threads - 37° Flare - Others
2. Put the sizes from the biggest down to the smallest if they are of the same type.
3. Put the female before male if they are of the same type and size.

Note: "Ordering Number Description" is a reference to understand the combination rules of FITOK product part number. Not all combinations are available.

Hose Connectors and Sleeves

HC Series

Features

- ⦿ Used to connect soft plastic or rubber tubing
- ⦿ Working pressures and working temperatures are wider than those of the connected hoses
- ⦿ Stainless steel or brass is available
- ⦿ Shank design holds tubing inside diameter securely
- ⦿ Hose connectors are reusable



Hose Connectors

Tube Fittings

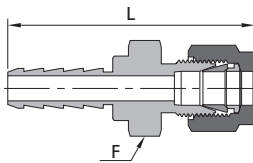

Hose ID	Tube Size	Basic Ordering Number	Dimensions		
			Minimum Inside Diameter	F	L
in.	in.		in. (mm)	in.	in. (mm)
1/8	1/8	-HC-F2-FL2	0.08 (2.0)	7/16	1.42 (36.1)
1/4	1/8	-HC-F4-FL2	0.09 (2.3)	7/16	1.81 (46.0)
	1/4	-HC-F4-FL4	0.19 (4.8)	9/16	1.92 (48.8)
3/8	1/4	-HC-F6-FL4	0.19 (4.8)	9/16	1.99 (50.6)
	3/8	-HC-F6-FL6	0.28 (7.1)	3/4	2.06 (52.3)
1/2	1/2	-HC-F8-FL8	0.38 (9.7)	7/8	2.24 (56.9)
mm	mm	—	mm (in.)	mm	mm (in.)
6	6	-HC-M6-ML6	4.8 (0.19)	14	49.5 (1.95)
8	8	-HC-M8-ML8	6.4 (0.25)	16	49.8 (1.96)
	10	-HC-M8-ML10	6.4 (0.25)	18	51.6 (2.03)
10	10	-HC-M10-ML10	7.9 (0.31)	19	52.3 (2.06)
12	12	-HC-M12-ML12	9.7 (0.38)	22	57.4 (2.26)

Tube Adapters

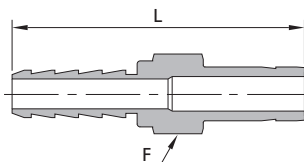

Hose ID	Tube Size	Basic Ordering Number	Dimensions		
			Minimum Inside Diameter	F	L
in.	in.		in. (mm)	in.	in. (mm)
1/8	1/8	-HC-F2-FT2	0.08 (2.0)	5/16	1.37 (34.8)
	1/4	-HC-F2-FT4	0.09 (2.3)	3/8	1.47 (37.3)
1/4	1/4	-HC-F4-FT4	0.19 (4.8)	7/16	1.86 (47.2)
	3/8	-HC-F4-FT6	0.19 (4.8)	7/16	1.92 (48.8)
5/16	1/4	-HC-F5-FT4	0.19 (4.8)	7/16	1.94 (49.3)
3/8	1/4	-HC-F6-FT4	0.19 (4.8)	9/16	1.94 (49.3)
	3/8	-HC-F6-FT6	0.28 (7.1)	9/16	2.00 (50.8)
	1/2	-HC-F6-FT8	0.30 (7.6)	5/8	2.26 (57.4)
1/2	3/8	-HC-F8-FT6	0.28 (7.1)	11/16	2.07 (52.6)
	1/2	-HC-F8-FT8	0.38 (9.7)	11/16	2.33 (59.2)
3/4	3/4	-HC-F12-FT12	0.63 (16.0)	13/16	2.50 (63.5)
1	1	-HC-F16-FT16	0.80 (20.3)	1 3/8	3.03 (77.0)

D-21 Hoses and Connectors

Male NPT

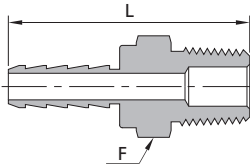

Hose ID	NPT Size	Basic Ordering Number	Dimensions		
			Minimum Inside Diameter	F	L
in.			in. (mm)	in.	in. (mm)
1/8	1/8	-HC-F2-NS2	0.08 (2.0)	7/16	1.08 (27.4)
	1/4	-HC-F2-NS4	0.08 (2.0)	9/16	1.26 (32.0)
3/16	1/8	-HC-F3-NS2	0.13 (3.3)	7/16	1.27 (32.2)
	1/4	-HC-F3-NS4	0.13 (3.3)	9/16	1.45 (36.8)
1/4	1/8	-HC-F4-NS2	0.19 (4.8)	7/16	1.47 (37.3)
	1/4	-HC-F4-NS4	0.19 (4.8)	9/16	1.65 (41.9)
	3/8	-HC-F4-NS6	0.19 (4.8)	11/16	1.66 (42.2)
	1/2	-HC-F4-NS8	0.19 (4.8)	7/8	1.85 (47.0)
5/16	1/8	-HC-F5-NS2	0.19 (4.8)	7/16	1.55 (39.4)
	1/4	-HC-F5-NS4	0.19 (4.8)	9/16	1.73 (43.9)
	3/8	-HC-F5-NS6	0.19 (4.8)	11/16	1.74 (44.2)
	1/2	-HC-F5-NS8	0.19 (4.8)	7/8	1.96 (49.8)
3/8	1/4	-HC-F6-NS4	0.30 (7.6)	9/16	1.73 (43.9)
	3/8	-HC-F6-NS6	0.30 (7.6)	11/16	1.74 (44.2)
	1/2	-HC-F6-NS8	0.30 (7.6)	7/8	1.96 (49.8)
1/2	1/4	-HC-F8-NS4	0.30 (7.6)	11/16	1.80 (45.7)
	3/8	-HC-F8-NS6	0.38 (9.7)	11/16	1.81 (46.0)
	1/2	-HC-F8-NS8	0.38 (9.7)	7/8	2.03 (51.6)
5/8	3/8	-HC-F10-NS6	0.38 (9.7)	1 1/16	1.88 (47.8)
	1/2	-HC-F10-NS8	0.47 (11.9)	1 1/16	2.07 (52.6)
	3/4	-HC-F10-NS12	0.50 (12.7)	1 1/16	2.07 (52.6)
3/4	1/2	-HC-F12-NS8	0.47 (11.9)	1 1/16	2.14 (54.4)
	3/4	-HC-F12-NS12	0.63 (16.0)	1 1/16	2.14 (54.4)
	1	-HC-F12-NS16	0.63 (16.0)	1 3/8	2.43 (61.7)
1	3/4	-HC-F16-NS12	0.63 (16.0)	1 3/8	2.38 (60.5)
	1	-HC-F16-NS16	0.88 (22.4)	1 3/8	2.57 (65.3)

Female NPT

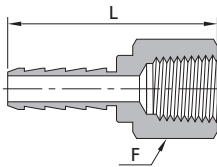

Hose ID	NPT Size	Basic Ordering Number	Dimensions		
			Minimum Inside Diameter	F	L
in.			in. (mm)	in.	in. (mm)
1/8	1/8	-HC-F2-FNS2	0.08 (2.0)	9/16	1.11 (28.2)
	1/4	-HC-F2-FNS4	0.08 (2.0)	3/4	1.26 (32.0)
3/16	1/8	-HC-F3-FNS2	0.13 (3.3)	9/16	1.29 (32.8)
	1/4	-HC-F3-FNS4	0.13 (3.3)	3/4	1.44 (36.6)
1/4	1/8	-HC-F4-FNS2	0.19 (4.8)	9/16	1.47 (37.3)
	1/4	-HC-F4-FNS4	0.19 (4.8)	3/4	1.64 (41.7)
	3/8	-HC-F4-FNS6	0.19 (4.8)	7/8	1.71 (43.4)
5/16	1/4	-HC-F5-FNS4	0.19 (4.8)	3/4	1.73 (43.9)
	3/8	-HC-F5-FNS6	0.19 (4.8)	7/8	1.82 (46.2)
3/8	1/4	-HC-F6-FNS4	0.30 (7.6)	3/4	1.69 (42.9)
	3/8	-HC-F6-FNS6	0.30 (7.6)	7/8	1.78 (45.2)
	1/2	-HC-F6-FNS8	0.30 (7.6)	1 1/16	2.03 (51.6)
1/2	1/2	-HC-F8-FNS8	0.38 (9.7)	1 1/16	2.13 (54.1)

Male BSPT

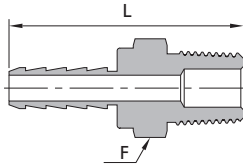

Hose ID	BSPT Size	Basic Ordering Number	Dimensions		
			Minimum Inside Diameter	F	L
in.			in. (mm)	in.	in. (mm)
1/8	1/8	-HC-F2-RT2	0.08 (2.0)	7/16	1.28 (32.5)
	1/4	-HC-F2-RT4	0.08 (2.0)	9/16	1.40 (35.5)
3/16	1/8	-HC-F3-RT2	0.13 (3.3)	7/16	1.40 (35.5)
	1/4	-HC-F3-RT4	0.13 (3.3)	9/16	1.58 (40.1)
1/4	1/8	-HC-F4-RT2	0.19 (4.8)	7/16	1.47 (37.3)
	1/4	-HC-F4-RT4	0.19 (4.8)	9/16	1.65 (41.9)
	3/8	-HC-F4-RT6	0.19 (4.8)	11/16	1.66 (42.2)
	1/2	-HC-F4-RT8	0.19 (4.8)	7/8	1.90 (48.3)
5/16	1/8	-HC-F5-RT2	0.19 (4.8)	7/16	1.67 (42.4)
	1/4	-HC-F5-RT4	0.19 (4.8)	9/16	1.86 (47.2)
	3/8	-HC-F5-RT6	0.19 (4.8)	11/16	1.87 (47.5)
	1/2	-HC-F5-RT8	0.19 (4.8)	7/8	2.10 (53.3)
3/8	1/4	-HC-F6-RT4	0.30 (7.6)	9/16	1.73 (43.9)
	3/8	-HC-F6-RT6	0.30 (7.6)	11/16	1.74 (44.2)
	1/2	-HC-F6-RT8	0.30 (7.6)	7/8	1.96 (49.8)
1/2	1/4	-HC-F8-RT4	0.30 (7.6)	11/16	1.80 (45.7)
	3/8	-HC-F8-RT6	0.38 (9.7)	11/16	1.81 (46.0)
	1/2	-HC-F8-RT8	0.38 (9.7)	7/8	2.03 (51.6)
5/8	3/8	-HC-F10-RT6	0.38 (9.7)	1 1/16	1.88 (47.8)
	1/2	-HC-F10-RT8	0.47 (11.9)	1 1/16	2.07 (52.6)
	3/4	-HC-F10-RT12	0.50 (12.7)	1 1/16	2.07 (52.6)
3/4	1/2	-HC-F12-RT8	0.47 (11.9)	1 1/16	2.14 (54.4)
	3/4	-HC-F12-RT12	0.63 (16.0)	1 1/16	2.14 (54.4)
	1	-HC-F12-RT16	0.63 (16.0)	1 3/8	2.43 (61.7)
1	3/4	-HC-F16-RT12	0.63 (16.0)	1 3/8	2.38 (60.5)
	1	-HC-F16-RT16	0.88 (22.4)	1 3/8	2.57 (65.3)

Female BSPT

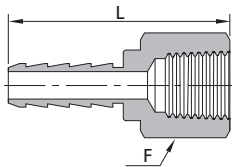

Hose ID	BSPT Size	Basic Ordering Number	Dimensions		
			Minimum Inside Diameter	F	L
in.			in. (mm)	in.	in. (mm)
1/8	1/8	-HC-F2-FRT2	0.08 (2.0)	9/16	1.11 (28.2)
	1/4	-HC-F2-FRT4	0.08 (2.0)	3/4	1.26 (32.0)
3/16	1/8	-HC-F3-FRT2	0.13 (3.3)	9/16	1.29 (32.8)
	1/4	-HC-F3-FRT4	0.13 (3.3)	3/4	1.44 (36.6)
1/4	1/8	-HC-F4-FRT2	0.19 (4.8)	9/16	1.47 (37.3)
	1/4	-HC-F4-FRT4	0.19 (4.8)	3/4	1.64 (41.7)
	3/8	-HC-F4-FRT6	0.19 (4.8)	7/8	1.71 (43.4)
5/16	1/4	-HC-F5-FRT4	0.19 (4.8)	3/4	1.73 (43.9)
	3/8	-HC-F5-FRT6	0.19 (4.8)	7/8	1.82 (46.2)
3/8	1/4	-HC-F6-FRT4	0.30 (7.6)	3/4	1.69 (42.9)
	3/8	-HC-F6-FRT6	0.30 (7.6)	7/8	1.78 (45.2)
	1/2	-HC-F6-FRT8	0.30 (7.6)	1 1/16	2.03 (51.6)
1/2	1/2	-HC-F8-FRT8	0.38 (9.7)	1 1/16	2.13 (54.1)

Hoses Quick-connects

Metric Thread

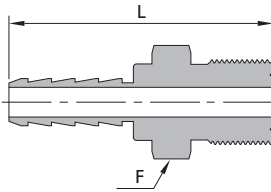

Hose ID	Thread Size	Basic Ordering Number	Dimensions		
			Minimum Inside Diameter	F	L
mm	in.		in. (mm)	mm	in. (mm)
6	M10 x 1	-HC-M6-MS10	4.3 (0.17)	12	39.6 (1.54)
	M12 x 1.5	-HC-M6-MS12	4.3 (0.17)	14	40.4 (1.59)
	M14 x 1.5	-HC-M6-MS14	4.3 (0.17)	15	42.2 (1.66)
8	M14 x 1.5	-HC-M8-MS14	4.8 (0.19)	15	44.2 (1.74)
	M16 x 1.5	-HC-M8-MS16	4.8 (0.19)	18	46.2 (1.82)
10	M16 x 1.5	-HC-M10-MS16	7.9 (0.31)	18	46.2 (1.82)
	M18 x 1.5	-HC-M10-MS18	7.9 (0.31)	19	47.2 (1.86)
12	M20 x 1.5	-HC-M12-MS20	8.9 (0.35)	22	50.3 (1.98)
	M22 x 1.5	-HC-M12-MS22	8.9 (0.35)	24	52.8 (2.08)

Hose Connector Sleeves

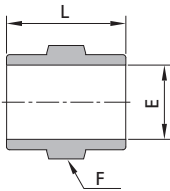

Hose ID	Hose OD	Ordering Number	Dimensions, in. (mm)		
			E	F	L
in.	in.				
1/8	1/4	AL-HC-F2-F4	0.26 (6.6)	3/8	0.40 (10.2)
1/4	3/8	AL-HC-F4-F6	0.41 (10.4)	9/16	0.79 (20.1)
1/4	7/16	AL-HC-F4-F7	0.46 (11.7)	5/8	0.79 (20.1)
1/4	1/2	AL-HC-F4-F8	0.52 (13.2)	11/16	0.79 (20.1)
5/16	7/16	AL-HC-F5-F7	0.48 (12.2)	5/8	0.87 (22.1)
3/8	1/2	AL-HC-F6-F8	0.55 (14.0)	11/16	0.87 (22.1)
3/8	9/16	AL-HC-F6-F9	0.61 (15.5)	3/4	0.87 (22.1)
7/16	5/8	AL-HC-F7-F10	0.69 (17.5)	13/16	0.94 (23.9)
1/2	11/16	AL-HC-F8-F11	0.76 (19.3)	7/8	0.94 (23.9)
3/4	1	AL-HC-F12-F16	1.10 (27.9)	1 1/4	1.07 (27.2)

- ⦿ Material: Aluminum
- ⦿ Reusable

Hose Clamps

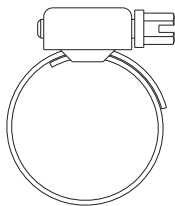

Min. Hose OD	Max. Hose OD	Ordering Number
mm	mm	
8	12	CP8-12
10	16	CP10-16
12	20	CP12-20
16	25	CP16-25
20	32	CP20-32
25	40	CP25-40

- ⦿ Material: 304 SS
- ⦿ Reusable

1. Sizes and types listed are standard. Other sizes and types are available upon request.
2. All dimensions are for reference only and are subject to change. For dimensions not shown above, please contact FITOK Group or our authorized distributors.

Ordering Number Description

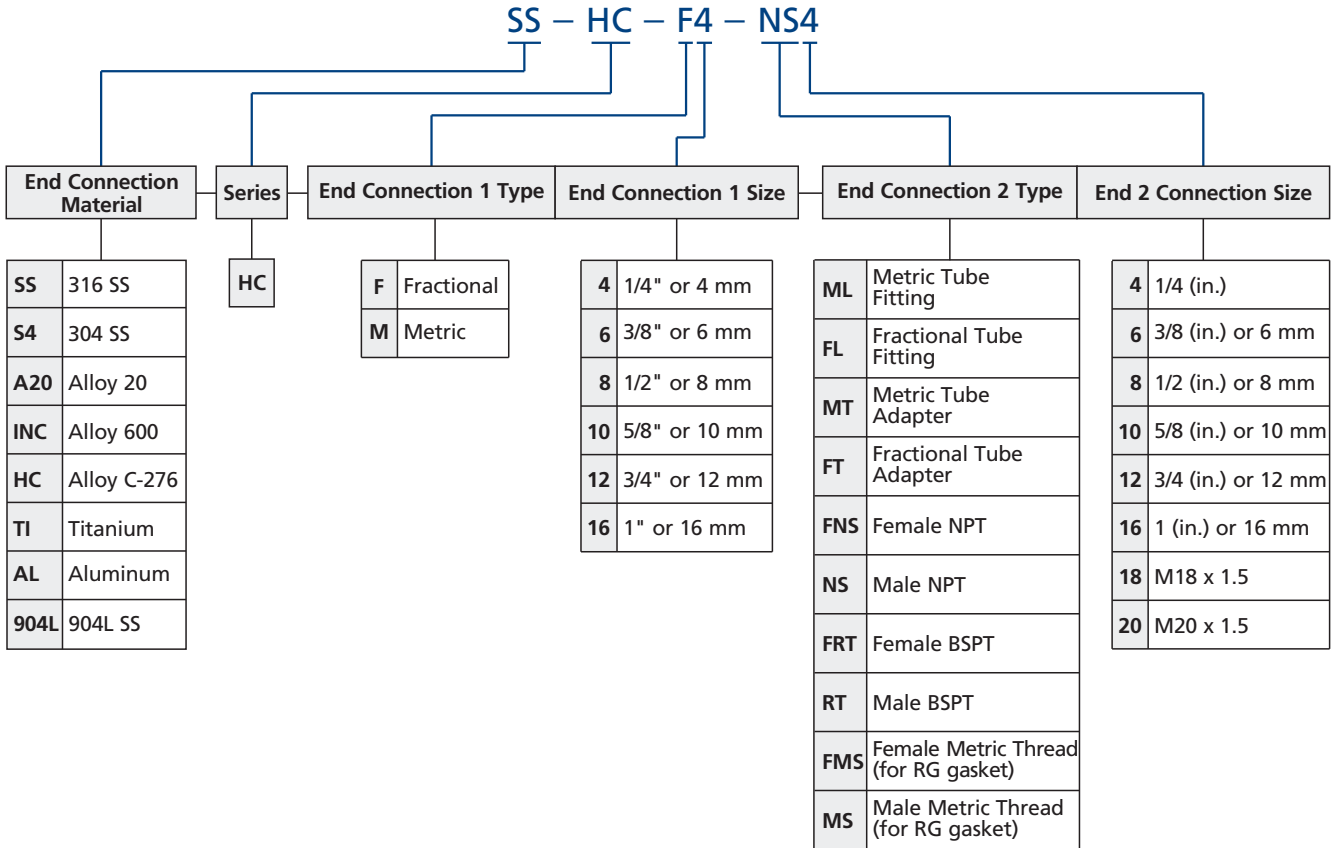

Example: SS-HC-F4-FT6

SS: End connection material is 316 stainless steel.

HC: HC series.

F4: Hose ID is 1/4" .

FT6: End connection 2 is 3/8" tube adapter.

Note: "Ordering Number Description" is a reference to understand the combination rules of FITOK product part number. Not all combinations are available.

Quick-connects

QC, QF, QV, QM and QTM Series



Contents

QC Series



D-27

QF Series



D-36

QV Series



D-41

QM Series



D-44

QTM Series



D-48

QC Series

Features

- ⦿ Working pressure up to: 3000 psig (207 bar)
- ⦿ Materials: Stainless steel or brass
- ⦿ Reliable, leak-tight O-ring seal for vacuum or pressure systems
- ⦿ Interchangeable with other key manufacturers' products
- ⦿ Single-end shutoff, double-end shutoff and full-flow model available
- ⦿ Push-to-connect coupling to enable quick and easy operation
- ⦿ Locking mechanism with large contact area to ensure reliable stem retainment
- ⦿ Stem protector, body protector and keyed options available

Single-end Shutoff (SESO)

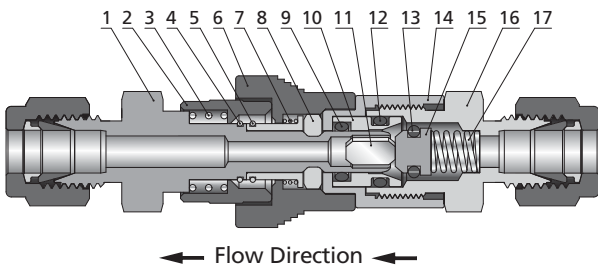

Double-end Shutoff (DESO) - Red Stem Sleeve

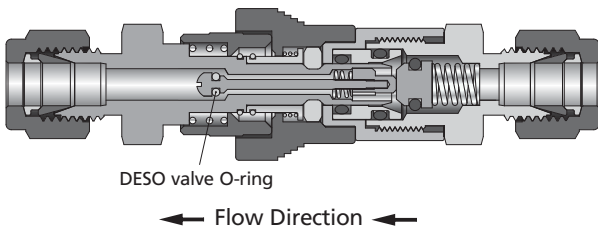

Full-flow Quick-connects

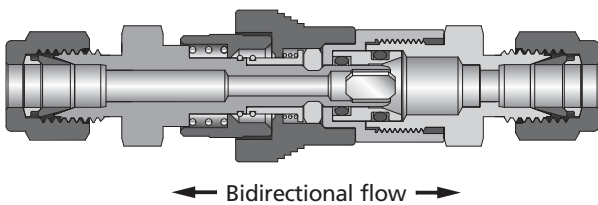

Standard Materials of Construction

Item	Component	Stainless Steel	Brass
		Material Grade/ASTM Standard	
1	Stem	316 SS/A479	Brass C36000/B16
2	DESO stem sleeve	PTFE-coated 316L SS/A479	PTFE-coated Brass C36000/B16
	SESO stem sleeve	316L SS/A479	Brass C36000/B16
3	Springs	316 SS/A313	
4	Snap rings	316 SS/A313	
5			
6	Body sleeve	316L SS/A479	Brass C36000/B16
7	Springs	316 SS/A313	
8	Locking dogs	Xylan [®] -coated 316 SS powdered metal	
9	O-rings	Fluorocarbon FKM	Buna N
10	Sliding sleeve	316 SS/A479	Brass C36000/B16
11	SESO stem insert	316 SS/A240	Brass C26000/B36
12	O-rings	Fluorocarbon FKM	Buna N
13	O-rings	Fluorocarbon FKM	Buna N
14	Housing	316L SS/A479	Brass C36000/B16
15	Plug	316 SS/A479	Brass C36000/B16
16	Body	316 SS/A479	Brass C36000/B16
17	Springs	316 SS/A313	
18	Lubricants	Silicone-based	

Insertion Depth

Series	Insertion Depth	
	SESO	DESO
	in. (mm)	in. (mm)
QC4	1.09 (27.7)	1.15 (29.2)
QC6	1.18 (30.0)	1.30 (33.0)
QC8	1.48 (37.6)	1.68 (42.7)

In order to measure overall length in the coupled position, the insertion depth should be deducted from any overall stem and body combination length.

Spillage and Air Inclusion

Spillage - the amount of system fluid that escapes when a quick-connect is uncoupled (DESO only)

Air Inclusion - the amount of air trapped between the body and stem that enters the system when a quick-connect is coupled (DESO only)

Series	Spillage, cm ³	Air Inclusion, cm ³
QC4	0.3	0.3
QC6	1.0	1.0
QC8	3.0	3.0

Pressure-Temperature Ratings

Pressure rating restrictions apply when coupling and uncoupling (DESO only). Refer to the tables below for specific data.

QC4 Series

Material	316 SS			Brass
O-Ring Material	Fluorocarbon FKM	Ethylene propylene	Perfluorocarbon FFKM	Buna N
Temperature °F (°C)	Pressure Rating, psig (bar)			
Coupled				
-50 (-45)	—	3000 (206)	—	—
0 (-17)	3000 (206)	3000 (206)	3000 (206)	2000 (137)
10 (-12)	3000 (206)	3000 (206)	3000 (206)	2000 (137)
60 (15)	3000 (206)	3000 (206)	3000 (206)	2000 (137)
100 (37)	3000 (206)	3000 (206)	3000 (206)	2000 (137)
150 (65)	2750 (189)	2750 (189)	2750 (189)	1300 (895)
200 (93)	2300 (158)	2300 (158)	2300 (158)	700 (48)
250 (121)	1850 (127)	1850 (127)	1850 (127)	300 (20.6)
300 (148)	1400 (96.4)	1400 (96.4)	1400 (96.4)	—
350 (176)	950 (65.4)	—	950 (65.4)	—
400 (204)	500 (34.4)	—	500 (34.4)	—
500 (260)	—	—	150 (10.3)	—
Uncoupled and When Coupling and Uncoupling				
70 (20)	250 (17.2)			

QC6 Series

Material	316 SS			Brass
O-Ring Material	Fluorocarbon FKM	Ethylene propylene	Perfluorocarbon FFKM	Buna N
Temperature °F (°C)	Pressure Rating, psig (bar)			
Coupled				
-50 (-45)	—	1500 (103)	—	—
0 (-17)	1500 (103)	1500 (103)	1500 (103)	1000 (68.9)
10 (-12)	1500 (103)	1500 (103)	1500 (103)	1000 (68.9)
60 (15)	1500 (103)	1500 (103)	1500 (103)	1000 (68.9)
100 (37)	1500 (103)	1500 (103)	1500 (103)	1000 (68.9)
150 (65)	1350 (93.0)	1350 (93.0)	1350 (93.0)	700 (48.2)
200 (93)	1150 (79.2)	1150 (79.2)	1150 (79.2)	450 (31.0)
250 (121)	970 (66.8)	970 (66.8)	970 (66.8)	300 (20.6)
300 (148)	750 (51.6)	750 (51.6)	750 (51.6)	—
350 (176)	580 (39.9)	—	580 (39.9)	—
400 (204)	400 (27.5)	—	400 (27.5)	—
500 (260)	—	—	150 (10.3)	—
Uncoupled and When Coupling and Uncoupling				
70 (20)	250 (17.2)			

QC8 Series

Material	316 SS			Brass
O-Ring Material	Fluorocarbon FKM	Ethylene propylene	Perfluorocarbon FFKM	Buna N
Temperature °F (°C)	Pressure Rating, psig (bar)			
Coupled				
-50 (-45)	—	750 (51.6)	—	—
0 (-17)	750 (51.6)	750 (51.6)	750 (51.6)	500 (34.4)
10 (-12)	750 (51.6)	750 (51.6)	750 (51.6)	500 (34.4)
60 (15)	750 (51.6)	750 (51.6)	750 (51.6)	500 (34.4)
100 (37)	750 (51.6)	750 (51.6)	750 (51.6)	500 (34.4)
150 (65)	680 (46.8)	680 (46.8)	680 (46.8)	400 (27.5)
200 (93)	600 (41.3)	600 (41.3)	600 (41.3)	350 (24.1)
250 (121)	520 (35.8)	520 (35.8)	520 (35.8)	300 (20.6)
300 (148)	440 (30.3)	440 (30.3)	440 (30.3)	—
350 (176)	360 (24.8)	—	360 (24.8)	—
400 (204)	300 (20.6)	—	300 (20.6)	—
500 (260)	—	—	150 (10.3)	—
Uncoupled and When Coupling and Uncoupling				
70 (20)	250 (17.2)			

Dimensions

SESO Stems

Tube Fitting

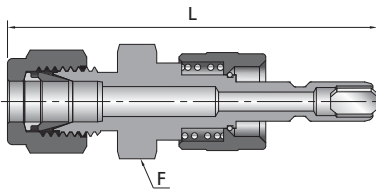

Male NPT

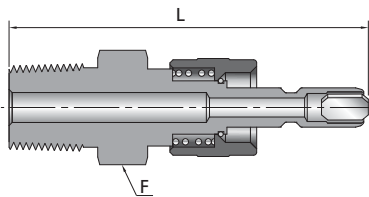

Female NPT

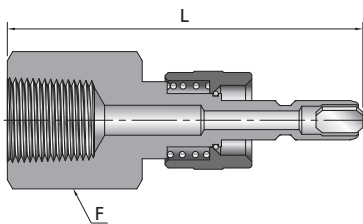

Male BSPT

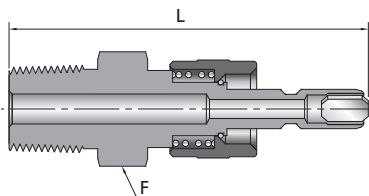

Female BSPT

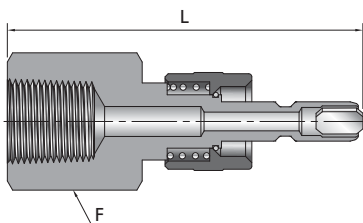

Male JIC(AN) 37° Flare

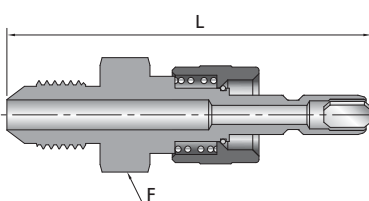

Fitting Size in.	Basic Ordering Number	Flow Coefficient (Cv)	Dimensions	
			F in.	L in. (mm)
1/8	-QC4-FL2-S	0.08	5/8	2.32 (58.9)
1/4	-QC4-FL4-S	0.3	5/8	2.36 (59.9)
3/8	-QC6-FL6-S	1.0	3/4	2.52 (64.0)
1/2	-QC8-FL8-S	2.4	15/16	2.96 (75.2)
mm			mm	mm (in.)
6	-QC4-ML6-S	0.3	16	59.9 (2.36)
10	-QC6-ML10-S	1.0	19	67.3 (2.65)
12	-QC8-ML12-S	2.4	24	75.2 (2.96)

NPT Size in.	Basic Ordering Number	Flow Coefficient (Cv)	Dimensions	
			F in.	L in. (mm)
1/8	-QC4-NS2-S	0.3	5/8	2.07 (52.6)
1/4	-QC4-NS4-S	0.3	5/8	2.22 (56.4)
1/4	-QC6-NS4-S	0.8	3/4	2.32 (58.9)
3/8	-QC6-NS6-S	0.8	3/4	2.35 (59.7)
1/2	-QC8-NS8-S	2.0	15/16	2.84 (72.1)

NPT Size in.	Basic Ordering Number	Flow Coefficient (Cv)	Dimensions	
			F in.	L in. (mm)
1/8	-QC4-FNS2-S	0.3	5/8	2.01 (51.1)
1/4	-QC4-FNS4-S	0.3	3/4	2.26 (57.4)
1/4	-QC6-FNS4-S	0.8	3/4	2.35 (59.7)
3/8	-QC6-FNS6-S	0.8	7/8	2.35 (59.7)
1/2	-QC8-FNS8-S	2.0	1 1/16	2.82 (71.6)

BSPT Size in.	Basic Ordering Number	Flow Coefficient (Cv)	Dimensions	
			F in.	L in. (mm)
1/8	-QC4-RT2-S	0.3	5/8	2.07 (52.6)
1/4	-QC4-RT4-S	0.3	5/8	2.22 (56.4)
1/4	-QC6-RT4-S	0.8	3/4	2.32 (58.9)
3/8	-QC6-RT6-S	0.8	3/4	2.35 (59.7)
1/2	-QC8-RT8-S	2.0	15/16	2.84 (72.1)

BSPT Size in.	Basic Ordering Number	Flow Coefficient (Cv)	Dimensions	
			F in.	L in. (mm)
1/8	-QC4-FRT2-S	0.3	5/8	2.01 (51.1)
1/4	-QC4-FRT4-S	0.3	3/4	2.26 (57.4)
1/4	-QC6-FRT4-S	0.8	3/4	2.35 (59.7)
3/8	-QC6-FRT6-S	0.8	7/8	2.35 (59.7)
1/2	-QC8-FRT8-S	2.0	1 1/16	2.82 (71.6)

Fitting Size in.	Basic Ordering Number	Flow Coefficient (Cv)	Dimensions	
			F in.	L in. (mm)
1/4	-QC4-AN4-S	0.2	5/8	2.23 (56.6)
3/8	-QC6-AN6-S	1.0	3/4	2.35 (59.7)
1/2	-QC8-AN8-S	2.4	15/16	2.79 (70.9)

Hose Connector

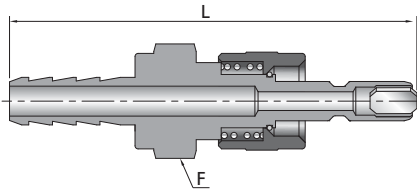

Hose Size in.	Basic Ordering Number	Flow Coefficient (Cv)	Dimensions	
			F	L
			in.	in. (mm)
1/4	-QC4-HC4-S	0.2	5/8	2.47 (62.7)
3/8	-QC6-HC6-S	1.0	3/4	2.66 (67.6)
1/2	-QC8-HC8-S	2.4	15/16	3.07 (78.0)

Bulkhead Tube Fitting

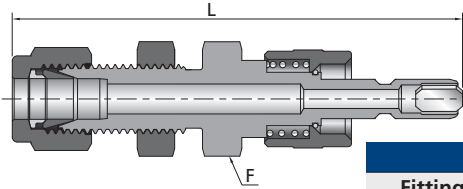

Fitting Size in.	Basic Ordering Number	Flow Coefficient (Cv)	Dimensions		Min. Panel Orifice in. (mm)	Max. Panel Thickness in. (mm)
			F	L		
			in.	in. (mm)		
1/4	-QC4-BFL4-S	0.3	5/8	2.74 (69.6)	0.47 (11.9)	0.25 (6.4)
3/8	-QC6-BFL6-S	1.0	3/4	2.92 (74.2)	0.60 (15.2)	0.27 (6.9)
1/2	-QC8-BFL8-S	2.4	15/16	3.43 (87.1)	0.78 (19.8)	0.26 (6.6)
mm	—	—	mm	mm (in.)	mm (in.)	mm (in.)
6	-QC4-BML6-S	0.3	16	69.6 (2.74)	11.7 (0.46)	6.4 (0.25)
10	-QC6-BML10-S	1.0	22	77.7 (3.06)	16.8 (0.66)	6.9 (0.27)
12	-QC8-BML12-S	2.4	24	87.1 (3.43)	19.6 (0.77)	6.6 (0.26)

DESO Stems

Tube Fitting

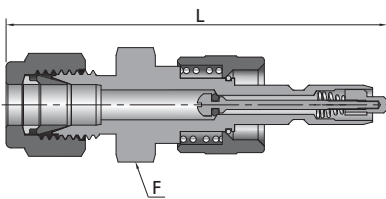

Fitting Size in.	Basic Ordering Number	Flow Coefficient (Cv)	Dimensions	
			F	L
			in.	in. (mm)
1/8	-QC4-FL2-D	0.08	5/8	2.77 (70.4)
1/4	-QC4-FL4-D	0.2	5/8	2.42 (61.5)
3/8	-QC6-FL6-D	0.5	3/4	2.64 (67.1)
1/2	-QC8-FL8-D	1.5	15/16	3.16 (80.3)
mm	—	—	mm	mm (in.)
6	-QC4-ML6-D	0.2	16	61.5 (2.42)
10	-QC6-ML10-D	0.5	19	70.4 (2.77)
12	-QC8-ML12-D	1.5	24	80.3 (3.16)

Male NPT

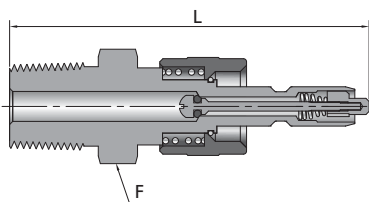

BSPT Size in.	Basic Ordering Number	Flow Coefficient (Cv)	Dimensions	
			F	L
			in.	in. (mm)
1/8	-QC4-NS2-D	0.2	5/8	2.13 (54.1)
1/4	-QC4-NS4-D	0.2	5/8	2.28 (57.8)
1/4	-QC6-NS4-D	0.5	3/4	2.44 (61.9)
3/8	-QC6-NS6-D	0.5	3/4	2.47 (62.7)
1/2	-QC8-NS8-D	1.3	15/16	3.04 (77.2)

Female NPT

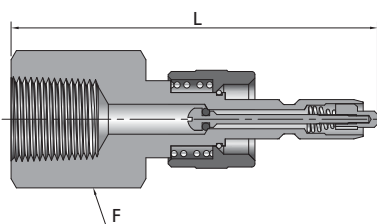

BSPT Size in.	Basic Ordering Number	Flow Coefficient (Cv)	Dimensions	
			F	L
			in.	in. (mm)
1/8	-QC4-FNS2-D	0.2	5/8	2.07 (52.6)
1/4	-QC4-FNS4-D	0.2	3/4	2.32 (58.9)
1/4	-QC6-FNS4-D	0.5	3/4	2.47 (62.7)
3/8	-QC6-FNS6-D	0.5	7/8	2.47 (62.7)
1/2	-QC8-FNS8-D	1.3	1 1/16	3.04 (77.2)

D-31 Quick-connects

Male BSPT

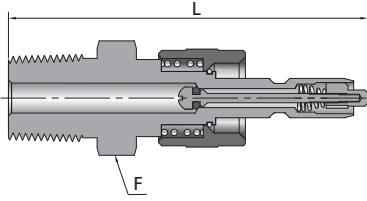

BSPT Size in.	Basic Ordering Number	Flow Coefficient (Cv)	Dimensions	
			F	L
			in.	in. (mm)
1/8	-QC4-RT2-D	0.2	5/8	2.13 (54.1)
1/4	-QC4-RT4-D	0.2	5/8	2.28 (57.8)
1/4	-QC6-RT4-D	0.5	3/4	2.44 (61.9)
3/8	-QC6-RT6-D	0.5	3/4	2.47 (62.7)
1/2	-QC8-RT8-D	1.3	15/16	3.04 (77.2)

Female BSPT

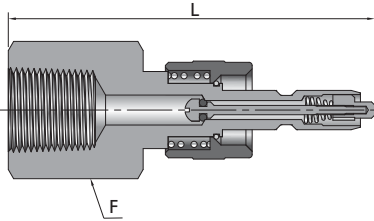

BSPT Size in.	Basic Ordering Number	Flow Coefficient (Cv)	Dimensions	
			F	L
			in.	in. (mm)
1/8	-QC4-FRT2-D	0.2	5/8	2.07 (52.6)
1/4	-QC4-FRT4-D	0.2	3/4	2.32 (58.9)
1/4	-QC6-FRT4-D	0.5	3/4	2.47 (62.7)
3/8	-QC6-FRT6-D	0.5	7/8	2.47 (62.7)
1/2	-QC8-FRT8-D	1.3	1 1/16	3.04 (77.2)

Male JIC(AN) 37° Flare

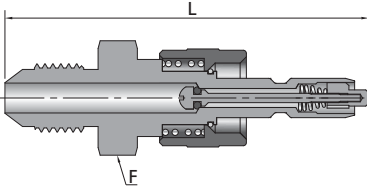

Fitting Size in.	Basic Ordering Number	Flow Coefficient (Cv)	Dimensions	
			F	L
			in.	in. (mm)
1/4	-QC4-AN4-D	0.2	5/8	2.29 (58.2)
3/8	-QC6-AN6-D	0.5	3/4	2.47 (62.7)
1/2	-QC8-AN8-D	1.5	15/16	2.99 (75.9)

Hose Connector

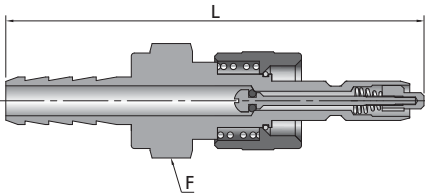

Hose Size in.	Basic Ordering Number	Flow Coefficient (Cv)	Dimensions	
			F	L
			in.	in. (mm)
1/4	-QC4-HC4-D	0.2	5/8	2.53 (64.3)
3/8	-QC6-HC6-D	0.5	3/4	2.78 (70.6)
1/2	-QC8-HC8-D	1.5	15/16	3.27 (83.1)

Bulkhead Tube Fitting

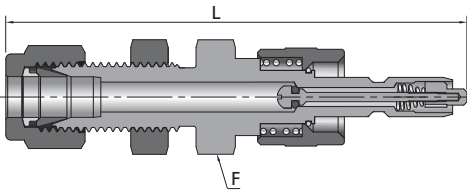

Fitting Size in.	Basic Ordering Number	Flow Coefficient (Cv)	Dimensions		Min. Panel Orifice in. (mm)	Max. Panel Thickness in. (mm)
			F	L		
			in.	in. (mm)		
1/4	-QC4-BFL4-D	0.2	5/8	2.80 (71.1)	0.47 (11.9)	0.25 (6.4)
3/8	-QC6-BFL6-D	0.5	3/4	3.07 (78.0)	0.60 (15.2)	0.27 (6.9)
1/2	-QC8-BFL8-D	1.5	15/16	3.63 (92.2)	0.78 (19.8)	0.26 (6.6)
mm	——	——	mm	mm (in.)	mm (in.)	mm (in.)
6	-QC4-BML6-D	0.2	16	71.1 (2.80)	11.7 (0.46)	6.4 (0.25)
10	-QC6-BML10-D	0.5	22	78.7 (3.10)	16.8 (0.66)	6.9 (0.27)
12	-QC8-BML12-D	1.5	24	92.2 (3.63)	19.6 (0.77)	6.6 (0.26)

Bodies

Tube Fitting

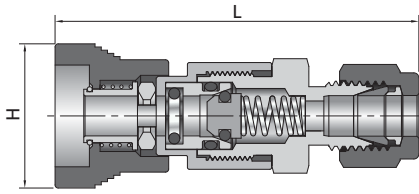

Male NPT

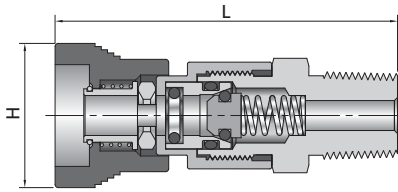

Female NPT

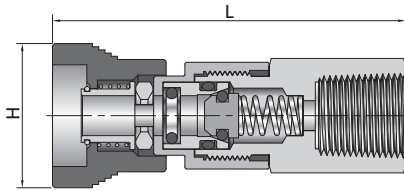

Male BSPT

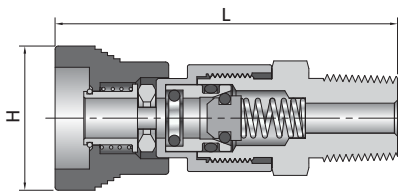

Female BSPT

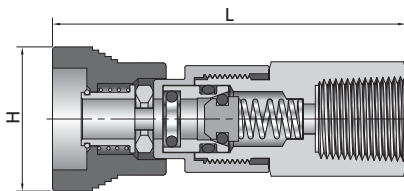

Male JIC (AN) 37° Flare

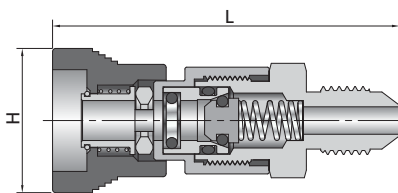

Fitting Size in.	Basic Ordering Number	Dimensions	
		H in.	L in. (mm)
1/8	-QC4-FL2-B	0.91 (23.1)	2.26 (57.4)
1/4	-QC4-FL4-B	0.91 (23.1)	2.30 (58.4)
3/8	-QC6-FL6-B	1.03 (26.2)	2.58 (65.5)
1/2	-QC8-FL8-B	1.21 (30.7)	3.09 (78.5)
mm		mm (in.)	mm (in.)
6	-QC4-ML6-B	23.1 (0.91)	58.4 (2.30)
10	-QC6-ML10-B	26.2 (1.03)	68.1 (2.68)
12	-QC8-ML12-B	30.7 (1.21)	78.5 (3.09)

NPT Size in.	Basic Ordering Number	Dimensions	
		H in.	L in. (mm)
1/8	-QC4-NS2-B	0.91 (23.1)	2.01 (51.1)
1/4	-QC4-NS4-B	0.91 (23.1)	2.16 (54.9)
1/4	-QC6-NS4-B	1.03 (26.2)	2.38 (60.5)
3/8	-QC6-NS6-B	1.03 (26.2)	2.38 (60.5)
1/2	-QC8-NS8-B	1.21 (30.7)	2.97 (75.4)

NPT Size in.	Basic Ordering Number	Dimensions	
		H in.	L in. (mm)
1/8	-QC4-FNS2-B	0.91 (23.1)	2.16 (54.9)
1/4	-QC4-FNS4-B	0.91 (23.1)	2.42 (61.5)
1/4	-QC6-FNS4-B	1.03 (26.2)	2.54 (64.5)
3/8	-QC6-FNS6-B	1.03 (26.2)	2.57 (65.3)
1/2	-QC8-FNS8-B	1.21 (30.7)	3.22 (81.8)

BSPT Size in.	Basic Ordering Number	Dimensions	
		H in.	L in. (mm)
1/8	-QC4-RT2-B	0.91 (23.1)	2.01 (51.1)
1/4	-QC4-RT4-B	0.91 (23.1)	2.16 (54.9)
1/4	-QC6-RT4-B	1.03 (26.2)	2.38 (60.5)
3/8	-QC6-RT6-B	1.03 (26.2)	2.38 (60.5)
1/2	-QC8-RT8-B	1.21 (30.7)	2.97 (75.4)

BSPT Size in.	Basic Ordering Number	Dimensions	
		H in.	L in. (mm)
1/8	-QC4-FRT2-B	0.91 (23.1)	2.16 (54.9)
1/4	-QC4-FRT4-B	0.91 (23.1)	2.42 (61.5)
1/4	-QC6-FRT4-B	1.03 (26.2)	2.54 (64.5)
3/8	-QC6-FRT6-B	1.03 (26.2)	2.57 (65.3)
1/2	-QC8-FRT8-B	1.21 (30.7)	3.22 (81.8)

Fitting Size in.	Basic Ordering Number	Dimensions	
		H in.	L in. (mm)
1/4	-QC4-AN4-B	0.91 (23.1)	2.17 (55.1)
3/8	-QC6-AN6-B	1.03 (26.2)	2.41 (61.2)
1/2	-QC8-AN8-B	1.21 (30.7)	2.92 (74.2)

D-33 Quick-connects

Hose Connector

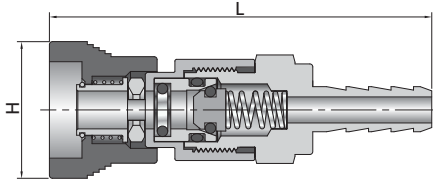

Hose Size in.	Basic Ordering Number	Dimensions	
		H in.	L in. (mm)
1/4	-QC4-HC4-B	0.91 (23.1)	2.41 (61.2)
3/8	-QC6-HC6-B	1.03 (26.2)	2.72 (69.1)
1/2	-QC8-HC8-B	1.21 (30.7)	3.20 (81.3)

Bulkhead Tube Fitting

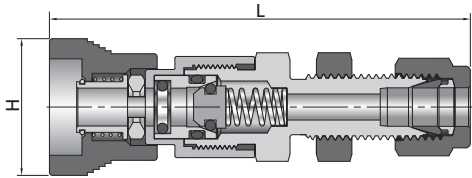

Fitting Size in.	Basic Ordering Number	Dimensions		Min. Panel Orifice in. (mm)	Max. Panel Thickness in. (mm)
		H in.	L in. (mm)		
1/4	-QC4-BFL4-B	0.91 (23.1)	2.67 (67.8)	0.47 (11.9)	0.25 (6.4)
3/8	-QC6-BFL6-B	1.03 (26.2)	2.98 (75.7)	0.60 (15.2)	0.27 (6.9)
1/2	-QC8-BFL8-B	1.21 (30.7)	3.56 (90.4)	0.78 (19.8)	0.26 (6.6)
mm	—	mm (in.)	mm (in.)	mm (in.)	mm (in.)
6	-QC4-BML6-B	23.1 (0.91)	67.8 (2.67)	11.7 (0.46)	6.4 (0.25)
10	-QC6-BML10-B	26.2 (1.03)	75.9 (2.99)	16.8 (0.66)	6.9 (0.27)
12	-QC8-BML12-B	30.7 (1.21)	90.4 (3.56)	19.6 (0.77)	6.6 (0.26)

Full-flow Bodies

Tube Fitting

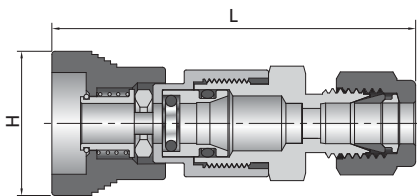

Fitting Size in.	Basic Ordering Number	Dimensions	
		H in.	L in. (mm)
1/8	-QC4-FL2-F	0.91 (23.1)	2.26 (57.4)
1/4	-QC4-FL4-F	0.91 (23.1)	2.30 (58.4)
3/8	-QC6-FL6-F	1.03 (26.2)	2.58 (65.5)
1/2	-QC8-FL8-F	1.21 (30.7)	3.09 (78.5)
mm	—	mm (in.)	mm (in.)
6	-QC4-ML6-F	23.1 (0.91)	58.4 (2.30)
10	-QC6-ML10-F	26.2 (1.03)	68.1 (2.68)
12	-QC8-ML12-F	30.7 (1.21)	78.5 (3.09)

Male NPT

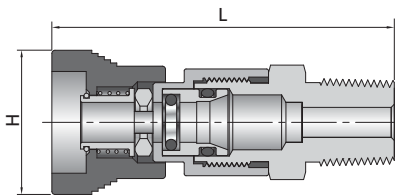

NPT Size in.	Basic Ordering Number	Dimensions	
		H in.	L in. (mm)
1/8	-QC4-NS2-F	0.91 (23.1)	2.01 (51.1)
1/4	-QC4-NS4-F	0.91 (23.1)	2.16 (54.9)
1/4	-QC6-NS4-F	1.03 (26.2)	2.38 (60.5)
3/8	-QC6-NS6-F	1.03 (26.2)	2.38 (60.5)
1/2	-QC8-NS8-F	1.21 (30.7)	2.97 (75.4)

Female NPT

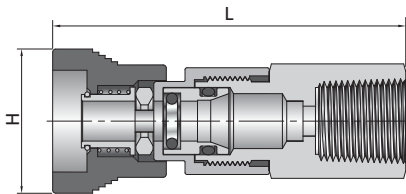

NPT Size in.	Basic Ordering Number	Dimensions	
		H in.	L in. (mm)
1/8	-QC4-FNS2-F	0.91 (23.1)	2.16 (54.9)
1/4	-QC4-FNS4-F	0.91 (23.1)	2.42 (61.5)
1/4	-QC6-FNS4-F	1.03 (26.2)	2.54 (65.4)
3/8	-QC6-FNS6-F	1.03 (26.2)	2.57 (65.3)
1/2	-QC8-FNS8-F	1.21 (30.7)	3.22 (81.8)

Male BSPT

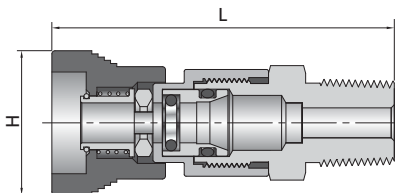

BSPT Size in.	Basic Ordering Number	Dimensions	
		H in.	L in. (mm)
1/8	-QC4-RT2-F	0.91 (23.1)	2.01 (51.1)
1/4	-QC4-RT4-F	0.91 (23.1)	2.16 (54.9)
1/4	-QC6-RT4-F	1.03 (26.2)	2.38 (60.5)
3/8	-QC6-RT6-F	1.03 (26.2)	2.38 (60.5)
1/2	-QC8-RT8-F	1.21 (30.7)	2.97 (75.4)

Female BSPT

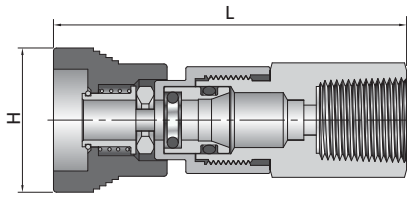

Male JIC (AN) 37° Flare

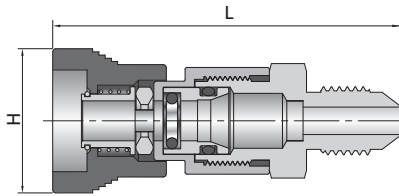

Hose Connector

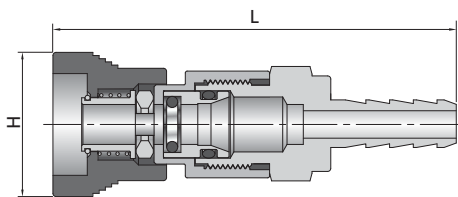

Bulkhead Tube Fitting

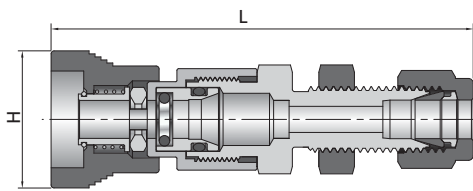

BSPT Size in.	Basic Ordering Number	Dimensions	
		H in.	L in. (mm)
1/8	-QC4-FRT2-F	0.91 (23.1)	2.16 (54.9)
1/4	-QC4-FRT4-F	0.91 (23.1)	2.42 (61.5)
1/4	-QC6-FRT4-F	1.03 (26.2)	2.54 (64.5)
3/8	-QC6-FRT6-F	1.03 (26.2)	2.57 (65.3)
1/2	-QC8-FRT8-F	1.21 (30.7)	3.22 (81.8)

Fitting Size in.	Basic Ordering Number	Dimensions	
		H in.	L in. (mm)
1/4	-QC4-AN4-F	0.91 (23.1)	2.17 (55.1)
3/8	-QC6-AN6-F	1.03 (26.2)	2.41 (61.2)
1/2	-QC8-AN8-F	1.21 (30.7)	2.92 (74.2)

Hose Size in.	Basic Ordering Number	Dimensions	
		H in.	L in. (mm)
1/4	-QC4-HC4-F	0.91 (23.1)	2.41 (61.2)
3/8	-QC6-HC6-F	1.03 (26.2)	2.72 (69.1)
1/2	-QC8-HC8-F	1.21 (30.7)	3.20 (81.3)

Fitting Size in.	Basic Ordering Number	Dimensions		Min. Panel Orifice in. (mm)	Max. Panel Thickness in. (mm)
		H in.	L in. (mm)		
1/4	-QC4-BFL4-F	0.91 (23.1)	2.67 (67.8)	0.47 (11.9)	0.25 (6.4)
3/8	-QC6-BFL6-F	1.03 (26.2)	2.98 (75.7)	0.60 (15.2)	0.27 (6.9)
1/2	-QC8-BFL8-F	1.21 (30.7)	3.56 (90.4)	0.78 (19.8)	0.26 (6.6)
mm		mm (in.)	mm (in.)	mm (in.)	mm (in.)
6	-QC4-BML6-F	23.1 (0.91)	67.8 (2.67)	11.7 (0.46)	6.4 (0.25)
10	-QC6-BML10-F	26.2 (1.03)	75.9 (2.99)	16.8 (0.66)	6.9 (0.27)
12	-QC8-BML12-F	30.7 (1.21)	90.4 (3.56)	19.6 (0.77)	6.6 (0.26)

Options, QC Series

Keyed QC Series

FITOK keyed quick-connects provide a reliable mechanical lockout system to prevent accidental intermixing of different lines in multifluid or multipressure systems.

QC Series Key Numbers and Sleeve Outside Diameters

Key Number	Color	QC4		QC6		QC8	
		Body Sleeve	Stem Sleeve	Body Sleeve	Stem Sleeve	Body Sleeve	Stem Sleeve
		in. (mm)	in. (mm)	in. (mm)	in. (mm)	in. (mm)	in. (mm)
K1	Black	0.96 (24.4)	0.82 (20.8)	1.13 (28.7)	0.99 (25.1)	1.26 (32.0)	1.10 (27.9)
K2	Orange	0.99 (25.1)	0.85 (21.6)	1.16 (29.5)	1.02 (25.9)	1.29 (32.8)	1.14 (29.0)
K3	Green	1.02 (25.9)	0.88 (22.4)	1.19 (30.2)	1.05 (26.7)	1.32 (33.5)	1.17 (29.7)
K4	Yellow	1.05 (26.7)	0.91 (23.1)	1.22 (31.0)	1.08 (27.4)	1.35 (34.3)	1.20 (30.5)
K5	Blue	1.08 (27.4)	0.94 (23.9)	1.24 (31.5)	1.11 (28.2)	1.38 (35.1)	1.23 (31.2)
K6	White	1.11 (28.2)	0.97 (24.6)	1.28 (32.5)	1.14 (29.0)	1.41 (35.8)	1.26 (32.0)
K7	Purple	1.14 (29.0)	1.00 (25.4)	1.31 (33.3)	1.17 (29.7)	1.44 (36.6)	1.29 (32.8)
K8	Brown	1.17 (29.7)	1.03 (26.2)	1.34 (34.0)	1.20 (30.5)	1.47 (37.3)	1.32 (33.5)

Stem and Body Protector

Stem and body protector can prevent the stem and the body from being damaged and polluted when uncoupling.

Stem Protector

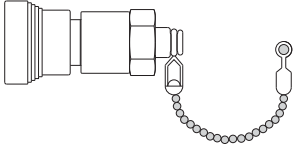

Series	Basic Ordering Number
QC4	-QC4-SP
QC6	-QC6-SP
QC8	-QC8-SP

Body Protector

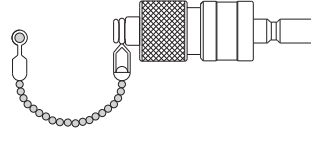

Series	Basic Ordering Number
QC4	-QC4-BP
QC6	-QC6-BP
QC8	-QC8-BP

- Ordering number description of the protector: Material designator (SS for stainless steel or B for brass) + Basic Ordering Number.
Example: **SS-QC4-BP**
- Ordering number description of the keyed protector: Material designator (SS for stainless steel or B for brass) + Basic Ordering Number+Key Number from the table below.
Example: **SS-QC4-BP-K2**
- The protector is not a pressure sustaining device. To order it, please contact FITOK Group or our authorized distributors.

Ordering Number Description

SS - QC4 - FL4 - S - K1 - B - CE

Material	Series	End Connection Type	End Connection Size	Stem or Body	Key Number and Color	O-ring Material	Special Application
SS 316 SS	QC4 1/4" (6.4 mm)	FNS Female NPT	4 1/4"	S Stem without valve remains open when uncoupled	Without key	Fluorocarbon FKM	NO
B Brass	QC6 3/8" (9.5 mm)	NS Male NPT	6 3/8" or 6 mm	D Stem with valve shuts off when uncoupled	K1 Black	B Buna N	CE NACE MR 0175
	QC8 1/2" (12.7 mm)	FRT Female BSPT	8 1/2" or 8 mm	B Body with valve shuts off when uncoupled	K2 Orange	E EPDM	
		RT Male BSPT	10 5/8" or 10 mm	F Full-flow body	K3 Green	N Neoprene	
		FMS Female Metric Thread (for RG gasket)	12 3/4" or 12 mm		K4 Yellow	Z Kalrez	
		MS Male Metric Thread (for RG gasket)	14 M14 x 1.5		K5 Blue		
		FL Fractional Tube Fitting	16 1" or 16 mm		K6 White		
		ML Metric Tube Fitting	18 M18 x 1.5		K7 Purple		
		FT Fractional Tube Adapter	20 M20 x 1.5		K8 Brown		
		MT Metric Tube Adapter					
		AN Male JIC 37° Flare					

- Note: 1. "Ordering Number Description" is a reference to understand the combination rules of FITOK product part number. Not all combinations are available.
2. Dimensions are for reference only and are subject to change.

QF Series

Features

- ⦿ Working pressure up to: 6000 psig (414 bar)
- ⦿ Materials: stainless steel or brass
- ⦿ Full flow
- ⦿ Quick, easy operation
- ⦿ Smooth and open bores without valve on either end to minimize pressure drop and allow easy cleaning

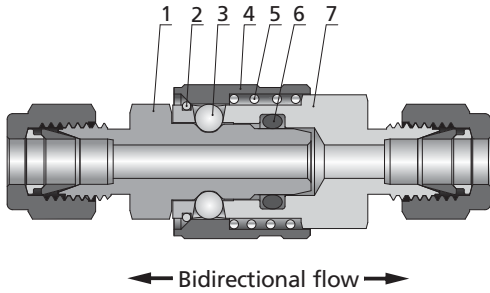

Standard Materials of Construction

Item	Component	Stainless Steel	Brass
		Material Grade/ASTM Standard	
1	Stem	316 SS/A479	Brass C36000/B16
2	Snap rings	316 SS/A313	
3	Locking balls	440C/A276	
4	Sliding sleeve	316L SS/A479	C36000/B16
5	Springs	316 SS/A313	
6	O-rings	Fluorocarbon FKM	Buna N
7	Body	316 SS/A479	Brass C36000/B16
8	Lubricants	Silicone-based	

Insertion Depth

Series	Insertion Depth
	in. (mm)
QF4	0.78 (19.8)
QF8	0.81 (20.6)
QF12	0.90 (22.9)
QF16	0.94 (23.9)

In order to measure overall length in the coupled position, insertion depth should be deducted from any overall stem and body combination length.

Pressure-Temperature Ratings

1. Pressure ratings may be limited by end connections.
2. Quick-connects in compliance with NACE MR0175 are subject to a lower pressure rating. For more information, please Contact FITOK Group or our authorized distributors.
3. Do not uncouple under pressure.

QF4 Series and QF8 Series

Material	316 SS			Brass	
	Fluorocarbon FKM	Ethylene propylene	Perfluorocarbon FFKM	Buna N	
Series	QF4 and QF8			QF4	QF8
Temperature °F (°C)	Pressure Rating, psig (bar)				
Coupled					
-50 (-45)	—	6000 (413)	—	—	—
0 (-17)	6000 (413)	6000 (413)	6000 (413)	4000 (275)	3000 (206)
10 (-12)	6000 (413)	6000 (413)	6000 (413)	4000 (275)	3000 (206)
40 (4)	6000 (413)	6000 (413)	6000 (413)	4000 (275)	3000 (206)
100 (37)	6000 (413)	6000 (413)	6000 (413)	4000 (275)	3000 (206)
150 (65)	5000 (344)	4000 (275)	5000 (344)	2700 (186)	2000 (137)
200 (93)	4000 (275)	2700 (186)	4000 (275)	1400 (96.4)	1000 (68.9)
250 (121)	3000 (206)	1400 (96.4)	3000 (206)	300 (20.6)	300 (20.6)
300 (148)	2000 (137)	400 (27.5)	2000 (137)	—	—
350 (176)	1200 (82.6)	—	1200 (82.6)	—	—
400 (204)	400 (27.5)	—	400 (27.5)	—	—
500 (260)	—	—	200 (13.7)	—	—

QF12 Series and QF16 Series

Material	316 SS			Brass
O-Ring Material	Fluorocarbon FKM	Ethylene propylene	Perfluorocarbon FFKM	Buna N
Temperature °F (°C)	Pressure Rating, psig (bar)			
Coupled				
-50 (-45)	—	4000 (275)	—	—
0 (-17)	4000 (275)	4000 (275)	4000 (275)	2000 (137)
10 (-12)	4000 (275)	4000 (275)	4000 (275)	2000 (137)
40 (4)	4000 (275)	4000 (275)	4000 (275)	2000 (137)
100 (37)	4000 (275)	4000 (275)	4000 (275)	2000 (137)
150 (65)	3500 (241)	2000 (137)	3500 (241)	1300 (89.5)
200 (93)	2800 (192)	1300 (89.5)	2800 (192)	700 (48.2)
250 (121)	2100 (144)	700 (48.2)	2100 (144)	200 (13.7)
300 (148)	1400 (96.4)	200 (13.7)	1400 (96.4)	—
350 (176)	800 (55.1)	—	800 (55.1)	—
400 (204)	200 (13.7)	—	200 (13.7)	—
500 (260)	—	—	150 (10.3)	—

Dimensions

Stems

Tube Fitting

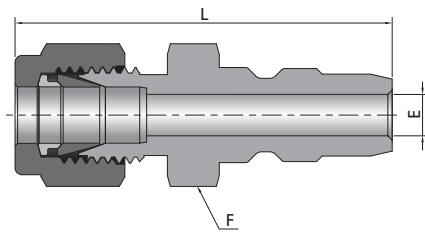

Fitting Size in.	Basic Ordering Number	Flow Coefficient (Cv)	Dimensions		
			E in. (mm)	F in.	L in. (mm)
1/4	-QF4-FL4-S	2.2	0.19 (4.8)	9/16	1.77 (45.0)
3/8	-QF4-FL6-S	2.8	0.24 (6.1)	11/16	1.77 (45.0)
3/8	-QF8-FL6-S	2.8	0.28 (7.1)	7/8	1.88 (47.8)
1/2	-QF8-FL8-S	13.0	0.41 (10.4)	7/8	1.99 (50.5)
3/4	-QF12-FL12-S	26.0	0.62 (15.7)	1 1/16	2.15 (54.6)
1	-QF16-FL16-S	45.0	0.88 (22.4)	1 3/8	2.45 (62.2)
mm			(mm) in.	mm	(mm) in.
6	-QF4-ML6-S	2.2	4.8 (0.19)	15	45.0 (1.77)
10	-QF8-ML10-S	2.8	7.1 (0.28)	22	48.5 (1.91)
12	-QF8-ML12-S	13.0	9.5 (0.37)	22	51.3 (2.02)
20	-QF12-ML20-S	26.0	15.7 (0.62)	30	54.6 (2.15)
25	-QF16-ML25-S	45.0	22.4 (0.88)	36	63.5 (2.50)

Male NPT

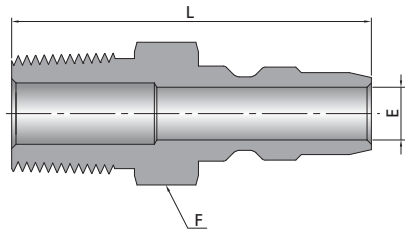

NPT Size in.	Basic Ordering Number	Flow Coefficient (Cv)	Dimensions		
			E in. (mm)	F in.	L in. (mm)
1/4	-QF4-NS4-S	1.7	0.24 (6.1)	9/16	1.59 (40.4)
3/8	-QF4-NS6-S	1.7	0.24 (6.1)	11/16	1.59 (40.4)
3/8	-QF8-NS6-S	7.1	0.41 (10.4)	7/8	1.65 (41.9)
1/2	-QF8-NS8-S	11.5	0.50 (12.7)	7/8	1.84 (46.7)
3/4	-QF12-NS12-S	23.6	0.72 (18.3)	1 1/16	2.03 (51.6)
1	-QF16-NS16-S	39.0	0.88 (22.4)	1 3/8	2.35 (59.7)

Stems

Female NPT

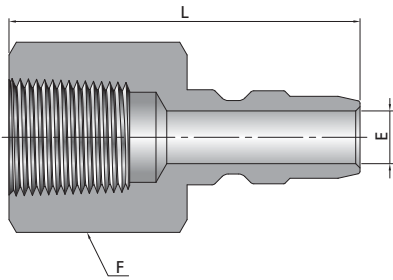

NPT Size in.	Basic Ordering Number	Flow Coefficient (Cv)	Dimensions		
			E	F	L
			in. (mm)	in.	in. (mm)
1/4	-QF4-FNS4-S	1.7	0.24 (6.1)	3/4	1.60 (40.6)
3/8	-QF4-FNS6-S	1.7	0.24 (6.1)	7/8	1.67 (42.4)
3/8	-QF8-FNS6-S	7.1	0.41 (10.4)	1 1/16	1.59 (40.4)
1/2	-QF8-FNS8-S	11.5	0.50 (12.7)	1 1/16	1.82 (46.2)
3/4	-QF12-FNS12-S	23.6	0.72 (18.3)	1 5/16	2.08 (52.8)
1	-QF16-FNS16-S	39.0	0.88 (22.4)	1 5/8	2.49 (63.2)

Male BSPT

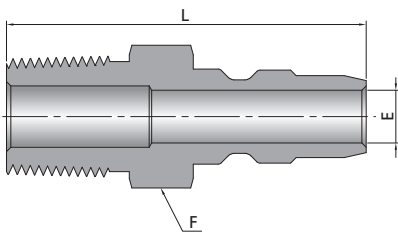

BSPT Size in.	Basic Ordering Number	Flow Coefficient (Cv)	Dimensions		
			E	F	L
			in. (mm)	in.	in. (mm)
1/4	-QF4-RT4-S	1.7	0.24 (6.1)	9/16	1.59 (40.4)
3/8	-QF4-RT6-S	1.7	0.24 (6.1)	11/16	1.59 (40.4)
3/8	-QF8-RT6-S	7.1	0.41 (10.4)	7/8	1.65 (41.9)
1/2	-QF8-RT8-S	11.5	0.50 (12.7)	7/8	1.84 (46.7)
3/4	-QF12-RT12-S	23.6	0.72 (18.3)	1 1/16	2.03 (51.6)
1	-QF16-RT16-S	39.0	0.88 (22.4)	1 3/8	2.35 (59.7)

Female BSPT

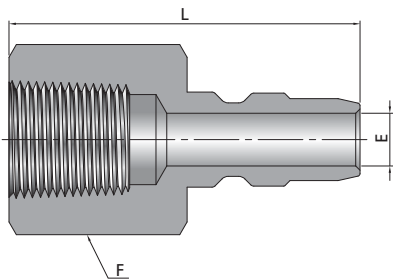

BSPT Size in.	Basic Ordering Number	Flow Coefficient (Cv)	Dimensions		
			E	F	L
			in. (mm)	in.	in. (mm)
1/4	-QF4-FRT4-S	1.7	0.24 (6.1)	3/4	1.60 (40.6)
3/8	-QF4-FRT6-S	1.7	0.24 (6.1)	7/8	1.67 (42.4)
3/8	-QF8-FRT6-S	7.1	0.41 (10.4)	1 1/16	1.59 (40.4)
1/2	-QF8-FRT8-S	11.5	0.50 (12.7)	1 1/16	1.82 (46.2)
3/4	-QF12-FRT12-S	23.6	0.72 (18.3)	1 5/16	2.08 (52.8)
1	-QF16-FRT16-S	39.0	0.88 (22.4)	1 5/8	2.49 (63.2)

Bodies

Tube Fitting

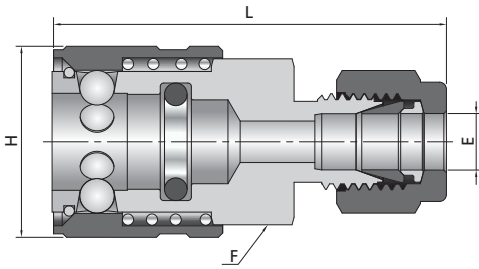

Male NPT

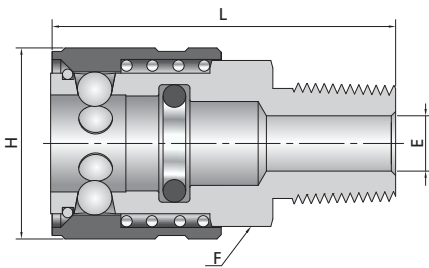

Female NPT

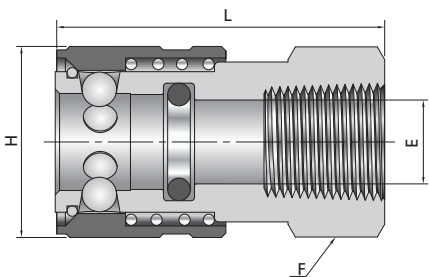

Male BSPT

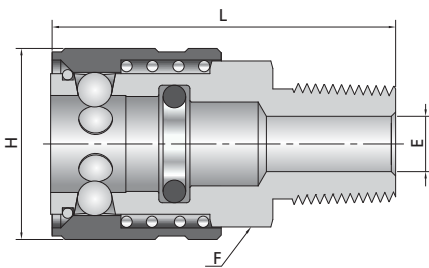

Female BSPT

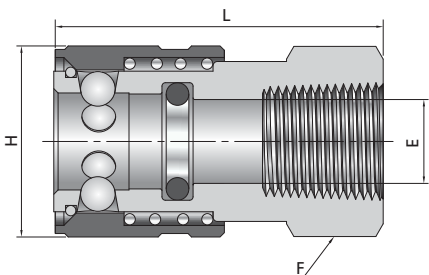

Fitting Size in.	Basic Ordering Number	Dimensions			
		E in. (mm)	F in.	H in. (mm)	L in. (mm)
1/4	-QF4-FL4-B	0.19 (4.8)	11/16	0.87 (22.1)	1.80 (45.7)
3/8	-QF4-FL6-B	0.28 (7.1)	11/16	0.87 (22.1)	1.81 (46.0)
3/8	-QF8-FL6-B	0.28 (7.1)	1 1/16	1.30 (33.0)	2.17 (55.1)
1/2	-QF8-FL8-B	0.47 (11.9)	1 1/16	1.30 (33.0)	2.23 (56.6)
3/4	-QF12-FL12-B	0.62 (15.7)	1 1/2	1.66 (42.2)	2.45 (62.2)
1	-QF16-FL16-B	0.88 (22.4)	1 11/16	1.88 (47.8)	2.75 (69.9)
mm	---	(mm) in.	mm	(mm) in.	(mm) in.
6	-QF4-ML6-B	4.8 (0.19)	18	22.1 (0.87)	45.7 (1.80)
10	-QF8-ML10-B	7.1 (0.28)	27	33.0 (1.30)	55.9 (2.20)
12	-QF8-ML12-B	10.4 (0.41)	27	33.0 (1.30)	57.4 (2.26)
20	-QF12-ML20-B	15.9 (0.63)	38	42.2 (1.66)	63.5 (2.50)
25	-QF16-ML25-B	21.8 (0.86)	46	47.8 (1.88)	70.0 (2.76)

NPT Size in.	Basic Ordering Number	Dimensions			
		E in. (mm)	F in.	H in. (mm)	L in. (mm)
1/4	-QF4-NS4-B	0.25 (6.4)	11/16	0.87 (22.1)	1.57 (39.9)
3/8	-QF4-NS6-B	0.37 (9.4)	11/16	0.87 (22.1)	1.57 (39.9)
3/8	-QF8-NS6-B	0.41 (10.4)	1 1/16	1.30 (33.0)	1.83 (46.5)
1/2	-QF8-NS8-B	0.50 (12.7)	1 1/16	1.30 (33.0)	2.08 (52.8)
3/4	-QF12-NS12-B	0.72 (18.3)	1 1/2	1.66 (42.2)	2.33 (59.2)
1	-QF16-NS16-B	0.88 (22.4)	1 11/16	1.88 (47.8)	2.65 (67.3)

NPT Size in.	Basic Ordering Number	Dimensions			
		E in. (mm)	F in.	H in. (mm)	L in. (mm)
1/4	-QF4-FNS4-B	0.38 (9.7)	3/4	0.87 (22.1)	1.50 (38.1)
3/8	-QF4-FNS6-B	0.38 (9.7)	7/8	0.87 (22.1)	1.63 (41.4)
3/8	-QF8-FNS6-B	0.59 (15.0)	1 1/16	1.30 (33.0)	1.73 (43.9)
1/2	-QF8-FNS8-B	0.63 (16.0)	1 1/16	1.30 (33.0)	1.73 (43.9)
3/4	-QF12-FNS12-B	0.88 (22.4)	1 1/2	1.66 (42.2)	1.89 (48.0)
1	-QF16-FNS16-B	1.06 (26.9)	1 11/16	1.88 (47.8)	2.12 (53.8)

BSPT Size in.	Basic Ordering Number	Dimensions			
		E in. (mm)	F in.	H in. (mm)	L in. (mm)
1/4	-QF4-RT4-B	0.25 (6.4)	11/16	0.87 (22.1)	1.57 (39.9)
3/8	-QF4-RT6-B	0.37 (9.4)	11/16	0.87 (22.1)	1.57 (39.9)
3/8	-QF8-RT6-B	0.41 (10.4)	1 1/16	1.30 (33.0)	1.83 (46.5)
1/2	-QF8-RT8-B	0.50 (12.7)	1 1/16	1.30 (33.0)	2.08 (52.8)
3/4	-QF12-RT12-B	0.72 (18.3)	1 1/2	1.66 (42.2)	2.33 (59.2)
1	-QF16-RT16-B	0.88 (22.4)	1 11/16	1.88 (47.8)	2.65 (67.3)

BSPT Size in.	Basic Ordering Number	Dimensions			
		E in. (mm)	F in.	H in. (mm)	L in. (mm)
1/4	-QF4-FRT4-B	0.38 (9.7)	3/4	0.87 (22.1)	1.50 (38.1)
3/8	-QF4-FRT6-B	0.38 (9.7)	7/8	0.87 (22.1)	1.63 (41.4)
3/8	-QF8-FRT6-B	0.59 (15.0)	1 1/16	1.30 (33.0)	1.73 (43.9)
1/2	-QF8-FRT8-B	0.63 (16.0)	1 1/16	1.30 (33.0)	1.73 (43.9)
3/4	-QF12-FRT12-B	0.88 (22.4)	1 1/2	1.66 (42.2)	1.89 (48.0)
1	-QF16-FRT16-B	1.06 (26.9)	1 11/16	1.88 (47.8)	2.12 (53.8)

Options, QF Series

Stem and Body Protector

Stem and body protector can prevent the stem and the body from being damaged and polluted when uncoupling.

Stem Protector

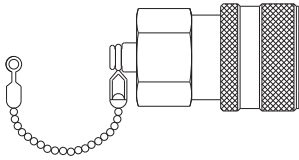

Series	Basic Ordering Number
QF4	-QF4-SP
QF8	-QF8-SP
QF12	-QF12-SP
QF16	-QF16-SP

Body Protector

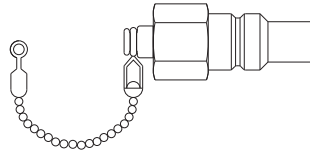

Series	Basic Ordering Number
QF4	-QF4-BP
QF8	-QF8-BP
QF12	-QF12-BP
QF16	-QF16-BP

- Ordering number description of the protector: Material designator (SS for stainless steel or B for brass) + Basic Ordering Number.
Example: **SS-QF4-BP**
- The protector is not a pressure sustaining device. To order it, please contact FITOK Group or our authorized distributors.

Ordering Number Description

SS - QF4 - FL4 - S - B - CE

Material		Series		End Connection Type		End Connection Size		Stem or Body		O-ring Material		Special Application	
SS	316SS	QF4	1/4" (6.4 mm)	FNS	Female NPT	4	1/4"	S	Stem		Fluorocarbon FKM		NO
B	Brass	QF8	1/2" (12.7 mm)	NS	Male NPT	6	3/8" or 6 mm	B	Body	B	Buna N	CE	NACE MR 0175
		QF12	3/4" (19.0 mm)	FRT	Female BSPT	8	1/2" or 8 mm			E	EPDM		
		QF16	1" (25.4 mm)	RT	Male BSPT	10	5/8" or 10 mm			N	Neoprene		
				FMS	Female Metric Thread (for RG gasket)	12	3/4" or 12 mm			Z	Kalrez		
				MS	Male Metric Thread (for RG gasket)	14	M14 x 1.5						
				FL	Fractional Tube Fitting	16	1" or 16 mm						
				ML	Metric Tube Fitting	18	M18 x 1.5						
				FT	Fractional Tube Adapter	20	M20 x 1.5						
				MT	Metric Tube Adapter								
				AN	Male JIC 37° Flare								

- Note: 1. "Ordering Number Description" is a reference to understand the combination rules of FITOK product part number. Not all combinations are available.
2. Dimensions are for reference only and are subject to change.

QV Series

Features

- ⦿ Working pressure up to: 2000 psig (137 bar)
- ⦿ Large flow area to ensure high flow capacity
- ⦿ Positive valve stop to maintain valve alignment and to provide metal to metal valve stop to ensure that the valves are fully open
- ⦿ Hardened nipples and sleeves as well as solid barstock construction to make for a quality coupling with maximum resistance to damage from hydraulic and mechanical shock
- ⦿ Designed to withstand high pressure with reliable sealing
- ⦿ Durable ball-locking mechanism to assure reliable connection

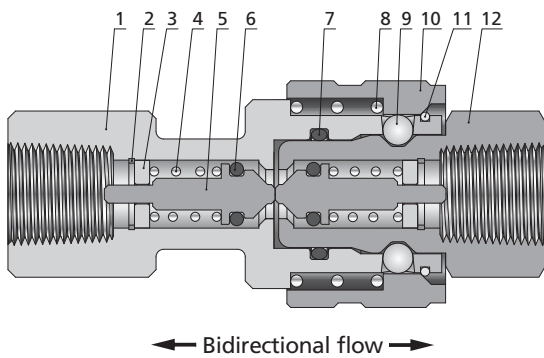

Standard Materials of Construction

Item	Component	Stainless Steel	Brass
		Material Grade/ASTM Standard	
1	Body	316 SS/A479	C36000/B16
2	Locating ring	304 SS	
3	Locating block	316 SS/A276	Brass C36000/B16
4	Springs	316 SS/A313	
5	Valve Stem	316 SS/A479	C36000/B16
6	O-rings	Fluorocarbon FKM	Buna N
7			
8	Springs	316 SS/A313	
9	Locking balls	440C/A276	
10	Body sleeve	316L SS/A479	Brass C36000/B16
11	Snap rings	316 SS/A313	
12	Stem	316 SS/A479	C36000/B16
13	Lubricants	Silicone-based	

Pressure-Temperature Ratings

Do not couple or uncouple under pressure.

Body Material	Stainless Steel						Brass					
	Series	QV2	QV4	QV6	QV8	QV12	QV16	QV2	QV4	QV6	QV8	QV12
O-ring	FKM						Buna N					
Temperature Range	-10°F to 400°F (-23°C to 204°C)						-10°F to 250°F (-23°C to 121°C)					
Working Pressure psig (bar)	2000 (137)		1500 (103)		1000 (69.0)		1000 (69.0)					

Insertion Depth

Series	Insertion Depth
	in. (mm)
QV2	0.81 (20.5)
QV4	0.98 (25)
QV6	1.17 (29.7)
QV8	1.26 (32)
QV12	1.64 (41.6)
QV16	1.93 (49.1)

In order to measure overall length in the coupled position, the insertion depth should be deducted from any overall stem and body combination length.

Dimensions

Stems

Female NPT

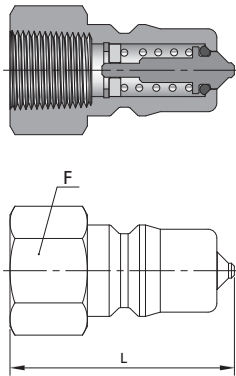

NPT Size in.	Basic Ordering Number	Flow Coefficient (Cv)	Dimensions	
			L in. (mm)	F in.
1/8	-QV2-FNS2-D	0.2	1.16 (29.5)	9/16
1/4	-QV4-FNS4-D	0.6	1.39 (35.3)	3/4
3/8	-QV6-FNS6-D	1.2	1.50 (38.1)	7/8
1/2	-QV8-FNS8-D	2.6	1.75 (44.5)	1 1/8
3/4	-QV12-FNS12-D	3.3	2.16 (54.9)	1 3/8
1	-QV16-FNS16-D	6.2	2.91 (73.9)	1 5/8

Female BSPT

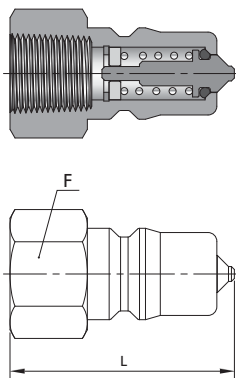

BSPT Size in.	Basic Ordering Number	Flow Coefficient (Cv)	Dimensions	
			L in. (mm)	F in.
1/8	-QV2-FRT2-D	0.2	1.16 (29.5)	9/16
1/4	-QV4-FRT4-D	0.6	1.39 (35.3)	3/4
3/8	-QV6-FRT6-D	1.2	1.50 (38.1)	7/8
1/2	-QV8-FRT8-D	2.6	1.75 (44.5)	1 1/8
3/4	-QV12-FRT12-D	3.3	2.16 (54.9)	1 3/8
1	-QV16-FRT16-D	6.2	2.91 (73.9)	1 5/8

Bodies

Female NPT

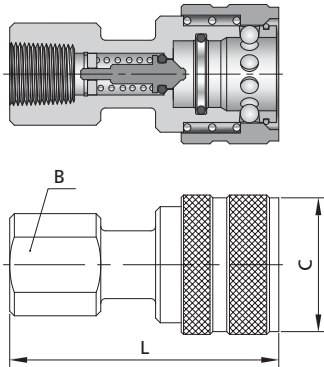

NPT Size in.	Basic Ordering Number	Dimensions		
		L in. (mm)	B in. (mm)	C in. (mm)
1/8	-QV2-FNS2-B	1.90 (48.3)	0.63 (15.9)	0.96 (24.4)
1/4	-QV4-FNS4-B	2.26 (57.4)	0.81 (20.6)	1.14 (29.0)
3/8	-QV6-FNS6-B	2.49 (63.2)	0.88 (22.2)	1.40 (35.6)
1/2	-QV8-FNS8-B	2.87 (72.9)	1.13 (28.6)	1.77 (45.0)
3/4	-QV12-FNS12-B	3.56 (90.4)	1.31 (33.3)	2.14 (54.4)
1	-QV16-FNS16-B	4.18 (106.2)	1.63 (41.3)	2.52 (64.0)

Female BSPT

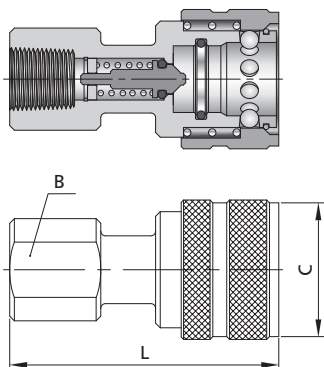

BSPT Size in.	Basic Ordering Number	Dimensions		
		L in. (mm)	B in. (mm)	C in. (mm)
1/8	-QV2-FRT2-B	1.90 (48.3)	0.69 (17.5)	0.96 (24.4)
1/4	-QV4-FRT4-B	2.26 (57.4)	0.81 (20.6)	1.14 (29.0)
3/8	-QV6-FRT6-B	2.49 (63.2)	0.88 (22.2)	1.40 (35.6)
1/2	-QV8-FRT8-B	2.87 (72.9)	1.13 (28.6)	1.77 (45.0)
3/4	-QV12-FRT12-B	3.56 (90.4)	1.31 (33.3)	2.14 (54.4)
1	-QV16-FRT16-B	4.18 (106.2)	1.63 (41.3)	2.52 (64.0)

Options, QV Series

Stem and Body Protector

Stem and body protector can prevent the stem and the body from being damaged and polluted when uncoupling.

Stem Protector

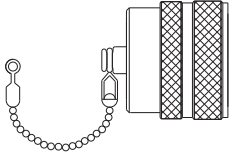

Series	Basic Ordering Number
QV2	-QV2-SP
QV4	-QV4-SP
QV6	-QV6-SP
QV8	-QV8-SP
QV12	-QV12-SP
QV16	-QV16-SP

Body Protector

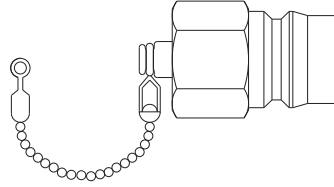

Series	Basic Ordering Number
QV2	-QV2-BP
QV4	-QV4-BP
QV6	-QV6-BP
QV8	-QV8-BP
QV12	-QV12-BP
QV16	-QV16-BP

- Ordering number description of the protector: Material designator (SS for stainless steel or B for brass) + Basic Ordering Number.
Example: **SS-QV4-BP**
- The protector is not a pressure sustaining device. To order it, please contact FITOK Group or our authorized distributors.

Ordering Number Description

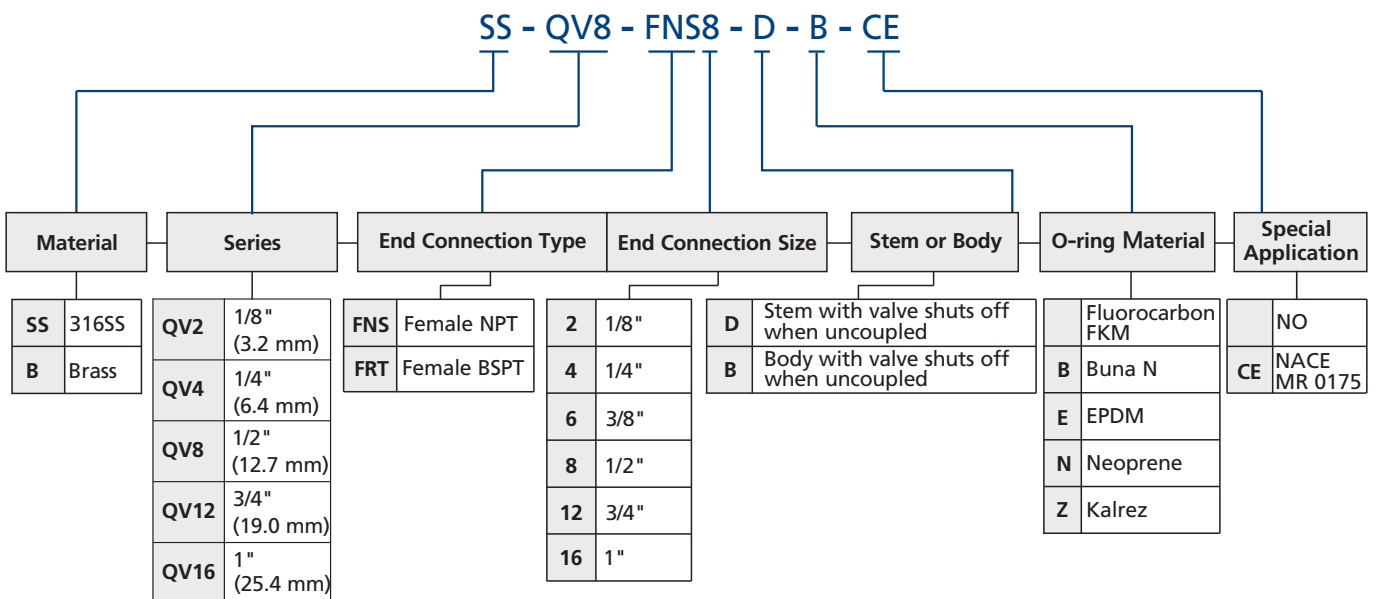

- Note: 1. "Ordering Number Description" is a reference to understand the combination rules of FITOK product part number. Not all combinations are available.
2. Dimensions are for reference only and are subject to change.

QM Series

Features

- ⦿ Working pressure up to: 4000 psig (276 bar)
- ⦿ Single-end shutoff, double-end shutoff and full-flow model available
- ⦿ Quick and easy operation

Double-end Shutoff (DESO)

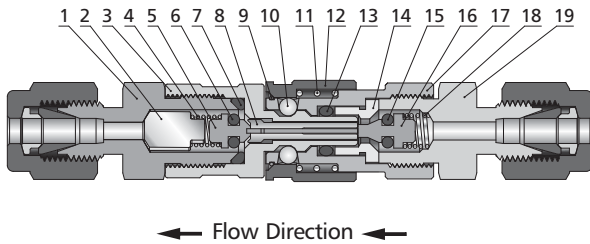

Single-end Shutoff (SESO)

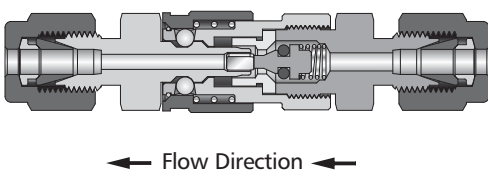

Full-flow Quick-connects

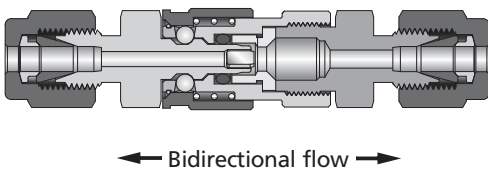

Insertion Depth

In order to measure overall length in the coupled position, insertion depth should be deducted from any overall stem and body combination length.

Depth in. (mm)	
SESO	DESO
0.47 (11.9)	0.53 (13.5)

Spillage and Air Inclusion

0.1cm³
(DESO only)

Standard Materials of Construction

Item.	Component	Material Grade/ASTM Standard	
		Stainless Steel	Brass
1	Stem body	316 SS/A479	Brass C36000/B16
2	Valve block	316 SS/A240	Brass C26000/B36
3	Stem	316 SS/A479	Brass C36000/B16
4	Springs	316 SS/A313	
5	Valve head	316 SS/A479	Brass C36000/B16
6	O-rings	Fluorocarbon FKM	
7		Buna N	
8	Stem insert	316 SS/A240	Brass C26000/B36
9	Snap rings	316 SS/A313	
10	Steel ball	440C/A276	
11	Springs	316 SS/A313	
12	Body sleeve	316L SS/A479	Brass C36000/B16
13	O-rings	Fluorocarbon FKM	Buna N
14	Insert	316 SS/A479	Brass C36000/B16
15	O-rings	Fluorocarbon FKM	Buna N
16	Valve head	316 SS/A479	Brass C36000/B16
17	housing	316 SS/A479	Brass C36000/B16
18	Springs	316 SS/A313	
19	Body	316 SS/A479	Brass C36000/B16
20	Lubricants	Silicone-based	

Pressure -Temperature Ratings

Pressure rating restrictions apply when coupling and uncoupling (DESO only). Refer to the table below for specific data.

Material	316 SS			Brass
	Fluorocarbon FKM	Ethylene propylene	Perfluorocarbon FFKM	Buna N
Temperature °F (°C)	Pressure Rating, psig (bar)			
Coupled				
-50 (-45)	—	4000 (275)	—	—
0 (-17)	4000 (275)	4000 (275)	4000 (275)	2000 (137)
10 (-12)	4000 (275)	4000 (275)	4000 (275)	2000 (137)
40 (4)	4000 (275)	4000 (275)	4000 (275)	2000 (137)
100 (37)	4000 (275)	4000 (275)	4000 (275)	2000 (137)
150 (65)	3500 (241)	3500 (241)	3500 (241)	1300 (89.5)
200 (93)	2800 (192)	2800 (192)	2800 (192)	700 (48)
250 (121)	2100 (144)	2100 (144)	2100 (144)	200 (13.7)
300 (148)	1400 (96.4)	1400 (96.4)	1400 (96.4)	—
350 (176)	800 (55.1)	—	800 (55.1)	—
400 (204)	200 (13.7)	—	200 (13.7)	—
500 (260)	—	—	150 (10.3)	—
Uncoupled and When Coupling and Uncoupling				
70 (20)	100 (6.8)			

Dimensions

SESO Stems

Tube Fitting

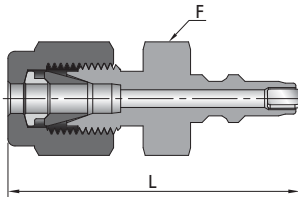

Fitting Size in.	Basic Ordering Number	Flow Coefficient (Cv)	Dimensions	
			L	F
			in. (mm)	in.
1/16	QM-FL1-S	0.06	1.18 (30.0)	7/16
1/8	QM-FL2-S		1.29 (32.8)	

Male NPT

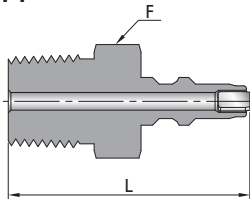

NPT Size in.	Basic Ordering Number	Flow Coefficient (Cv)	Dimensions	
			L	F
			in. (mm)	in.
1/16	QM-NS1-S	0.06	1.03 (26.2)	7/16
1/8	QM-NS2-S			

Female NPT

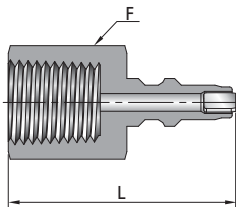

NPT Size in.	Basic Ordering Number	Flow Coefficient (Cv)	Dimensions	
			L	F
			in. (mm)	in.
1/16	QM-FNS1-S	0.06	1.03 (26.2)	7/16
1/8	QM-FNS2-S		1.18 (30.0)	9/16

DESO Stems

Tube Fitting

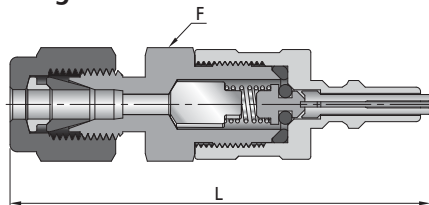

Fitting Size in.	Basic Ordering Number	Flow Coefficient (Cv)	Dimensions	
			L	F
			in. (mm)	in.
1/16	QM-FL1-D	0.05	1.76 (44.7)	7/16
1/8	QM-FL2-D		1.87 (47.5)	

Male NPT

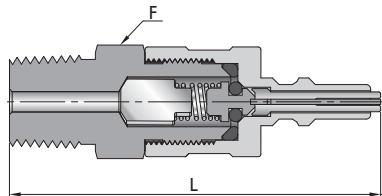

NPT Size in.	Basic Ordering Number	Flow Coefficient (Cv)	Dimensions	
			L	F
			in. (mm)	in.
1/16	QM-NS1-D	0.05	1.61 (40.9)	7/16
1/8	QM-NS2-D			

Female NPT

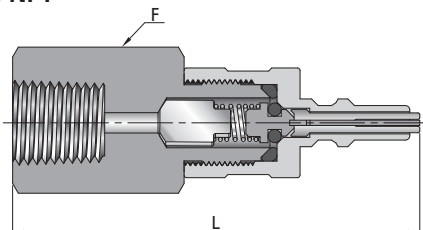

NPT Size in.	Basic Ordering Number	Flow Coefficient (Cv)	Dimensions	
			L	F
			in. (mm)	in.
1/16	QM-FNS1-D	0.05	1.61 (40.9)	7/16
1/8	QM-FNS2-D		1.81 (46.0)	9/16

Bodies

Tube Fitting

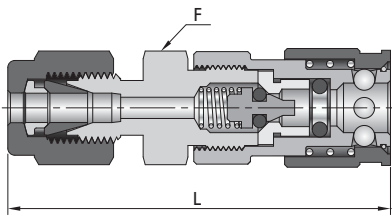

Fitting Size in.	Basic Ordering Number	Dimensions	
		L in. (mm)	F in.
1/16	QM-FL1-B	1.50 (38.1)	7/16
1/8	QM-FL2-B	1.70 (43.2)	

Male NPT

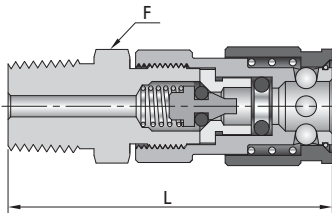

NPT Size in.	Basic Ordering Number	Dimensions	
		L in. (mm)	F in.
1/16	QM-NS1-B	1.42 (36.1)	7/16
1/8	QM-NS2-B	1.44 (36.6)	

Female NPT

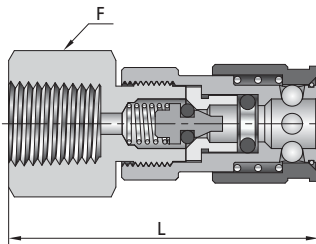

NPT Size in.	Basic Ordering Number	Dimensions	
		L in. (mm)	F in.
1/16	QM-FNS1-B	1.43 (36.3)	7/16
1/8	QM-FNS2-B	1.62 (41.1)	9/16

Bulkhead Tube Fitting

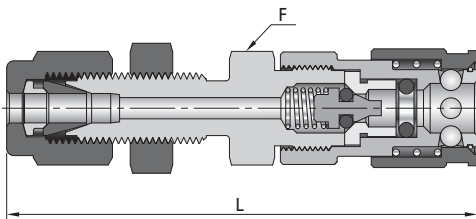

Fitting Size in.	Basic Ordering Number	Dimensions		Min. Panel Hole in. (mm)	Max. Panel Thickness in. (mm)
		A in. (mm)	F in.		
1/8	QM-BFL2-B	2.09 (53.1)	7/16	0.33 (8.3)	0.25 (6.4)

Full-flow Bodies

Tube Fitting

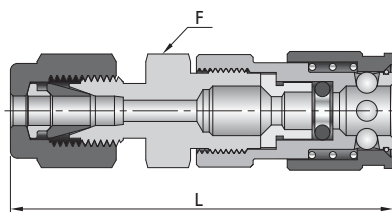

Fitting Size in.	Basic Ordering Number	Flow Coefficient (Cv)	Dimensions	
			L in. (mm)	F in.
1/16	QM-FL1-F	0.06	1.50 (38.1)	7/16
1/8	QM-FL2-F		1.70 (43.2)	

D-47 Quick-connects

Male NPT

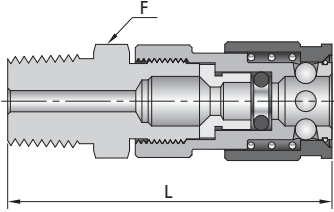

Fitting Size in.	Basic Ordering Number	Flow Coefficient (Cv)	Dimensions	
			L in. (mm)	F in.
1/16	QM-NS1-F	0.06	1.42 (36.1)	7/16
1/8	QM-NS2-F		1.44 (36.6)	

Female NPT

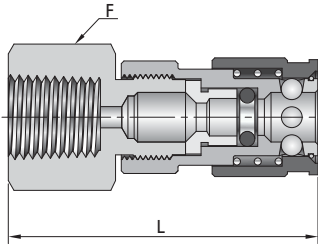

NPT Size in.	Basic Ordering Number	Flow Coefficient (Cv)	Dimensions	
			L in. (mm)	F in.
1/16	QM-FNS1-F	0.06	1.43 (36.3)	7/16
1/8	QM-FNS2-F		1.62 (41.1)	9/16

Ordering Number Description

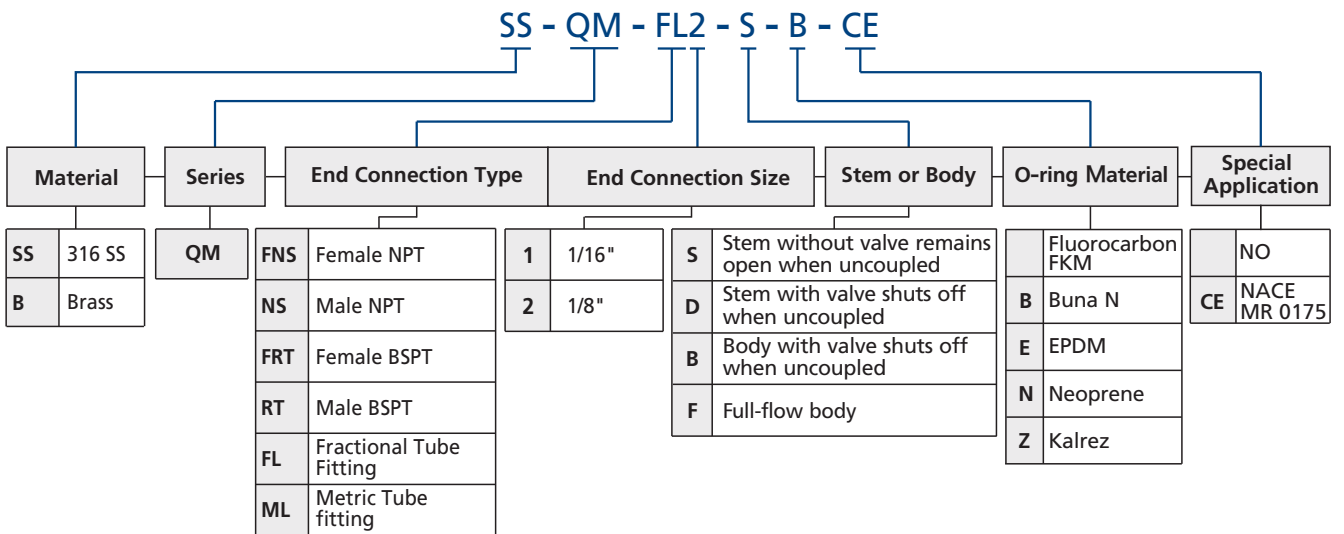

- Note: 1. "Ordering Number Description" is a reference to understand the combination rules of FITOK product part number. Not all combinations are available.
 2. Dimensions are for reference only and are subject to change.

QTM Series

Features

- ⦿ Working pressure up to: 4500 psig (310 bar)
- ⦿ Special design to reduce air inclusion and spillage
- ⦿ PTFE sealing to enable applications for diverse media types
- ⦿ Push-to-connect design to enable quick and easy operation
- ⦿ Locking mechanism with large contact area to ensure reliable stem retention
- ⦿ Keyed option available

Double-end Shutoff (DESO)

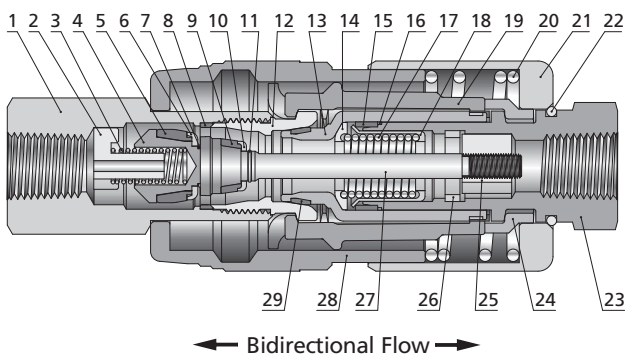

Single-end Shutoff (SESO)

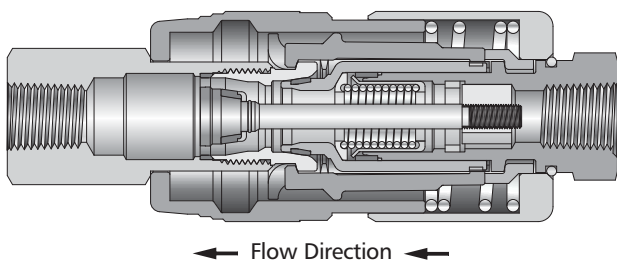

Pressure - Temperature Ratings

Temperature °F (°C)	316 SS			Alloy 400
	QTM2	QTM4	QTM8	QTM2
Pressure Rating, psig (bar)				
Coupled				
0~120 (-17~48)	4500 (310)	3200 (220)		3200 (220)
Uncoupled				
0~120 (-17~48)		1000 (68.9)		
When Coupling and Uncoupling				
70 (20)	250 (17.2)	100 (6.8)	50 (3.4)	250 (17.2)

Note: Pressure ratings may be restricted by end connections.

Standard Materials of Construction

Item	Component	Material	
1	Stem	316 SS/A479	Alloy 400/B164
2	Spring seat	316 SS/A479	Alloy 400/B164
3	Spring	316 SS/313	Alloy X-750/ AMS 5699
4	DESO valve	316 SS/A479	Alloy 400/B164
5	DESO seal ring	PTFE/D1710	PTFE/D1710
6	DESO stem fin	316 SS/A479	Alloy 400/B164
7	Roundwire snap ring for shaft	316 SS/A313	Alloy X-750/ AMS 5699
8	Adapter seal gasket	PTFE/D1710	PTFE/D1710
9	Body valve seal ring	PTFE/D1710	PTFE/D1710
10	Body fin	316 SS/A479	Alloy 400/B164
11	Roundwire snap ring for shaft	316 SS/A313	Alloy X-750/ AMS 5699
12	Stem adapter	316 SS/A479	Alloy 400/B164
13	Body sliding sleeve	316 SS/A479	Alloy 400/B164
14	Spring pad	316 SS/A479	Alloy 400/B164
15	Body packing ring	PTFE/D1710	PTFE/D1710
16	Packing backup ring	PTFE/D1710	PTFE/D1710
17	Spring	Elgiloy Alloy	Elgiloy Alloy
18	Body insert	316 SS/A479	Alloy 400/B164
19	Sliding hooks with spring ring	316 SS/A479	Alloy 400/B164
20	Spring	316 SS/A313	Alloy X-750/ AMS 5699
21	Body valve cap 2	316 SS/A479	Alloy 400/B164
22	Roundwire snap rings for shaft	316 SS/A313	Alloy X-750/ AMS 5699
23	Body	Xylan-coated 316 SS/A479	Xylan-coated alloy 400/B164
24	Locking block	316 SS/A479	Alloy 400/B164
25	Threaded connecting ring	316 SS/A479	Alloy 400/B164
26	Retaining ring	316 SS/A313	Alloy X-750/ AMS 5699
27	Body bolt	316 SS/A479	Alloy 400/B164
28	Body valve cap 1	316 SS/A479	Alloy 400/B164
29	Body valve seal ring	PTFE/D1710	PTFE/D1710
30	Lubricants	PTFE-based	PTFE-based

Spillage and Air Inclusion

DESO only

Series	Spillage cm ³	Air Inclusion cm ³
QTM2	0.1	0.1
QTM4	0.2	0.4
QTM8	1.0	2.0

Insertion Depth

Series	Depth in. (mm)
QTM2	1.26 (32.1)
QTM4	0.95 (24.0)
QTM8	1.15 (29.1)

In order to measure overall length in the coupled position, insertion depth should be deducted from any overall stem and body combination length.

Dimensions

DESO Stems

Tube Fitting

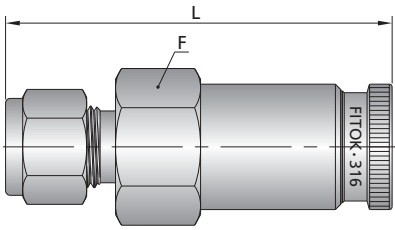

Fitting Size in.	Basic Ordering Number	Flow Coefficient (Cv)	Dimensions	
			L in. (mm)	F in.
1/4	-QTM2-FL4-D	0.6	2.02 (51.3)	5/8
1/4	-QTM4-FL4-D	0.8	2.61 (66.3)	15/16
3/8	-QTM2-FL6-D	0.8	2.08 (52.8)	11/16
3/8	-QTM4-FL6-D	1.6	2.67 (67.8)	15/16
1/2	-QTM8-FL8-D	3.1	3.06 (77.7)	1 5/16
3/4	-QTM8-FL12-D	6.5	3.06 (77.7)	1 5/16
1	-QTM8-FL16-D	7.8	3.27 (83.1)	1 3/8
mm			mm (in.)	mm
6	-QTM2-ML6-D	0.6	51.3 (2.02)	16
6	-QTM4-ML6-D	0.8	66.3 (2.61)	24
8	-QTM2-ML8-D	0.8	53.1 (2.09)	11/16 in.
10	-QTM4-ML10-D	1.6	68.1 (2.68)	24
12	-QTM8-ML12-D	3.1	77.7 (3.06)	35

Female NPT

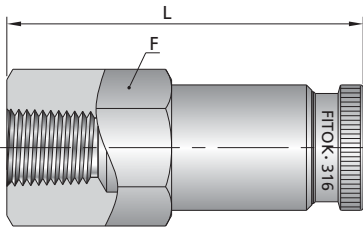

NPT Size in.	Basic Ordering Number	Flow Coefficient (Cv)	Dimensions	
			L in. (mm)	F in.
1/8	-QTM2-FNS2-D	0.7	1.73 (43.9)	5/8
1/4	-QTM2-FNS4-D	0.7	2.04 (51.8)	3/4
1/4	-QTM4-FNS4-D	1.4	2.36 (59.9)	15/16
3/8	-QTM2-FNS6-D	0.6	2.14 (54.4)	7/8
3/8	-QTM4-FNS6-D	1.7	2.48 (63.0)	15/16
1/2	-QTM8-FNS8-D	4.4	2.66 (67.6)	1 5/16
3/4	-QTM8-FNS12-D	7.8	2.66 (67.6)	1 5/16
1	-QTM8-FNS16-D	—	3.17 (80.5)	1 5/8

Female BSPT

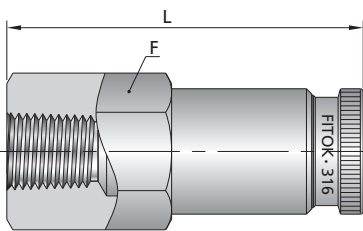

BSPT Size in.	Basic Ordering Number	Flow Coefficient (Cv)	Dimensions	
			L in. (mm)	F in.
1/8	-QTM2-FRT2-D	0.7	1.73 (43.9)	5/8
1/4	-QTM2-FRT4-D	0.7	2.04 (51.8)	3/4
1/4	-QTM4-FRT4-D	1.4	2.36 (59.9)	15/16
3/8	-QTM2-FRT6-D	0.6	2.14 (54.4)	7/8
3/8	-QTM4-FRT6-D	1.7	2.48 (63.0)	15/16
1/2	-QTM8-FRT8-D	4.4	2.66 (67.6)	1 5/16
3/4	-QTM8-FRT12-D	7.8	2.66 (67.6)	1 5/16
1	-QTM8-FRT16-D	—	3.17 (80.5)	1 5/8

Male NPT

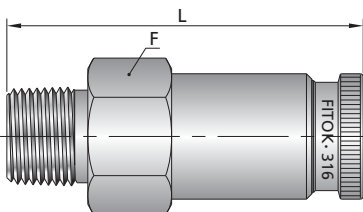

NPT Size in.	Basic Ordering Number	Flow Coefficient (Cv)	Dimensions	
			L in. (mm)	F in.
1/4	-QTM2-NS4-D	0.2	1.91 (48.5)	5/8
1/4	-QTM4-NS4-D	1.4	2.46 (62.5)	15/16
3/8	-QTM2-NS6-D	0.6	2.04 (51.8)	3/4
3/8	-QTM4-NS6-D	1.7	2.46 (62.5)	15/16
1/2	-QTM8-NS8-D	4.4	2.78 (70.6)	1 5/16
3/4	-QTM8-NS12-D	7.8	2.78 (70.6)	1 5/16
1	-QTM8-NS16-D	—	3.03 (77.0)	1 3/8

Male BSPT

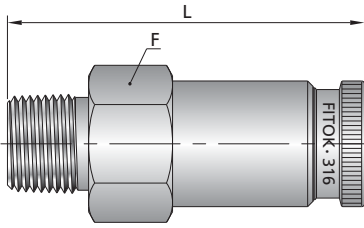

BSPT Size in.	Basic Ordering Number	Flow Coefficient (Cv)	Dimensions	
			L	F
			in. (mm)	in.
1/4	-QTM2-RT4-D	0.2	1.91 (48.5)	5/8
1/4	-QTM4-RT4-D	1.4	2.46 (62.5)	15/16
3/8	-QTM2-RT6-D	0.6	2.04 (51.8)	3/4
3/8	-QTM4-RT6-D	1.7	2.46 (62.5)	15/16
1/2	-QTM8-RT8-D	4.4	2.78 (70.6)	1 5/16
3/4	-QTM8-RT12-D	7.8	2.78 (70.6)	1 5/16
1	-QTM8-RT16-D	—	3.03 (77.0)	1 3/8

Male JIC (AN) 37° Flare

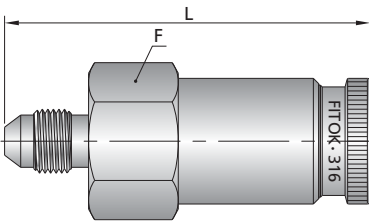

Fitting Size in.	Basic Ordering Number	Flow Coefficient (Cv)	Dimensions	
			L	F
			in. (mm)	in.
1/4	-QTM4-AN4-D	—	2.52 (64.0)	15/16
1/2	-QTM8-AN8-D	2.7	2.46 (70.6)	1 5/16

Bulkhead Tube Fitting

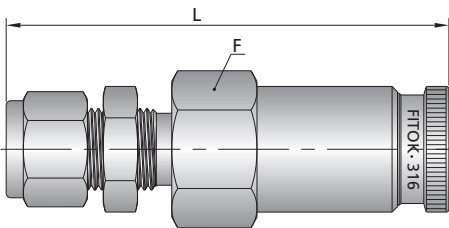

Fitting Size in.	Basic Ordering Number	Flow Coefficient (Cv)	Dimensions		Min. Panel Orifice in. (mm)	Max. Panel Thickness in. (mm)
			L	F		
			in. (mm)	in.		
1/4	-QTM4-BFL4-D	0.8	3.05 (77.5)	15/16	0.46 (11.7)	0.15 (3.8)
3/8	-QTM4-BFL6-D	1.6	3.05 (77.5)	15/16	0.58 (14.7)	0.15 (3.8)
1/2	-QTM8-BFL8-D	3.1	3.54 (89.9)	1 5/16	0.77 (19.6)	0.19 (4.8)
mm	—	—	mm (in.)	mm	mm (in.)	mm (in.)
6	-QTM4-BML6-D	0.8	77.5 (3.05)	24	11.7 (0.46)	3.8 (0.15)
10	-QTM4-BML10-D	1.6	77.7 (3.06)	24	16.8 (0.66)	3.8 (0.15)
12	-QTM8-BML12-D	3.1	89.9 (3.54)	35	19.6 (0.77)	4.8 (0.19)

SESO Stem

Tube Fitting

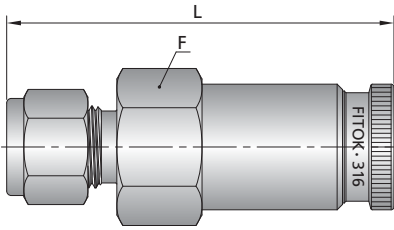

Fitting Size in.	Basic Ordering Number	Flow Coefficient (Cv)	Dimensions	
			L	F
			in. (mm)	in.
1/4	-QTM2-FL4-S	0.7	2.02 (51.3)	5/8
1/4	-QTM4-FL4-S	0.9	2.61 (66.3)	15/16
3/8	-QTM2-FL6-S	0.9	2.08 (52.8)	11/16
3/8	-QTM4-FL6-S	1.7	2.67 (67.8)	15/16
1/2	-QTM8-FL8-S	4.2	3.06 (77.7)	1 5/16
3/4	-QTM8-FL12-S	6.7	3.06 (77.7)	1 5/16
1	-QTM8-FL16-S	9.0	3.27 (83.1)	1 3/8
6	-QTM2-ML6-S	0.7	51.3 (2.02)	16
6	-QTM4-ML6-S	0.9	66.3 (2.61)	24
8	-QTM2-ML8-S	0.9	53.1 (2.09)	11/16 in.
10	-QTM4-ML10-S	1.7	68.1 (2.68)	24
12	-QTM8-ML12-S	4.2	77.7 (3.06)	35

Female NPT

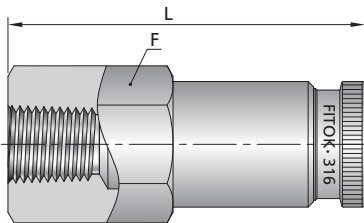

NPT Size in.	Basic Ordering Number	Flow Coefficient (Cv)	Dimensions	
			L	F
			in. (mm)	in.
1/8	-QTM2-FNS2-S	0.7	1.73 (43.9)	5/8
1/4	-QTM2-FNS4-S	0.7	2.04 (51.8)	3/4
1/4	-QTM4-FNS4-S	1.4	2.36 (59.9)	15/16
3/8	-QTM2-FNS6-S	0.7	2.14 (54.4)	7/8
3/8	-QTM4-FNS6-S	1.8	2.48 (63.0)	15/16
1/2	-QTM8-FNS8-S	5.1	2.66 (67.6)	1 5/16
3/4	-QTM8-FNS12-S	8.5	2.66 (67.6)	1 5/16
1	-QTM8-FNS16-S	—	3.17 (80.5)	1 5/8

Female BSPT

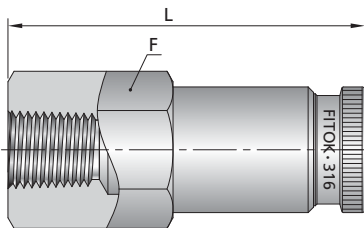

BSPT Size in.	Basic Ordering Number	Flow Coefficient (Cv)	Dimensions	
			L	F
			in. (mm)	in.
1/8	-QTM2-FRT2-S	0.7	1.73 (43.9)	5/8
1/4	-QTM2-FRT4-S	0.7	2.04 (51.8)	3/4
1/4	-QTM4-FRT4-S	1.4	2.36 (59.9)	15/16
3/8	-QTM2-FRT6-S	0.7	2.14 (54.4)	7/8
3/8	-QTM4-FRT6-S	1.8	2.48 (63.0)	15/16
1/2	-QTM8-FRT8-S	5.1	2.66 (67.6)	1 5/16
3/4	-QTM8-FRT12-S	8.5	2.66 (67.6)	1 5/16
1	-QTM8-FRT16-S	—	3.17 (80.5)	1 5/8

Male NPT

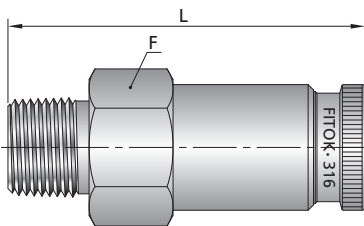

NPT Size in.	Basic Ordering Number	Flow Coefficient (Cv)	Dimensions	
			L	F
			in. (mm)	in.
1/4	-QTM2-NS4-S	0.2	1.91 (48.5)	5/8
1/4	-QTM4-NS4-S	1.4	2.46 (62.5)	15/16
3/8	-QTM2-NS6-S	0.7	2.04 (51.8)	3/4
3/8	-QTM4-NS6-S	1.8	2.46 (62.5)	15/16
1/2	-QTM8-NS8-S	5.1	2.78 (70.6)	1 5/16
3/4	-QTM8-NS12-S	8.5	2.78 (70.6)	1 5/16
1	-QTM8-NS16-S	—	3.03 (77.0)	1 3/8

Male BSPT

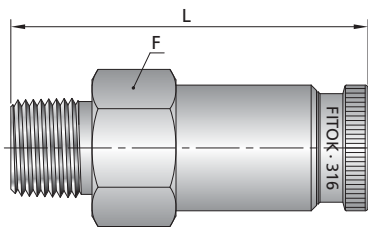

BSPT Size in.	Basic Ordering Number	Flow Coefficient (Cv)	Dimensions	
			L	F
			in. (mm)	in.
1/4	-QTM2-RT4-S	0.2	1.91 (48.5)	5/8
1/4	-QTM4-RT4-S	1.4	2.46 (62.5)	15/16
3/8	-QTM2-RT6-S	0.7	2.04 (51.8)	3/4
3/8	-QTM4-RT6-S	1.8	2.46 (62.5)	15/16
1/2	-QTM8-RT8-S	5.1	2.78 (70.6)	1 5/16
3/4	-QTM8-RT12-S	8.5	2.78 (70.6)	1 5/16
1	-QTM8-RT16-S	—	3.03 (77.0)	1 3/8

Male JIC(AN) 37° Flare

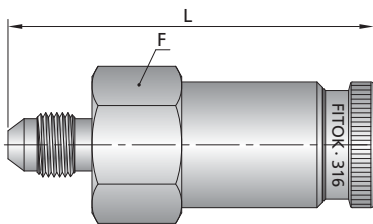

Fitting Size in.	Basic Ordering Number	Flow Coefficient (Cv)	Dimensions	
			L	F
			in. (mm)	in.
1/4	-QTM4-AN4-S	—	2.52 (64.0)	15/16
1/2	-QTM8-AN8-S	4.2	2.46 (70.6)	1 5/16

Bulkhead Tube Fitting

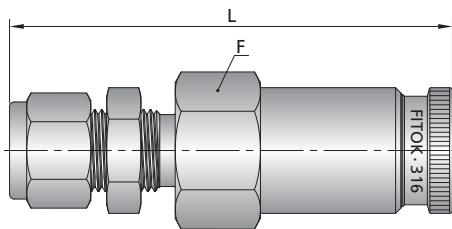

Fitting Size in.	Basic Ordering Number	Flow Coefficient (Cv)	Dimensions		Min. Panel Orifice in. (mm)	Max. Panel Thickness in. (mm)
			L	F		
			in. (mm)	in.		
1/4	-QTM4-BFL4-S	0.9	3.05 (77.5)	15/16	0.46 (11.7)	0.15 (3.8)
3/8	-QTM4-BFL6-S	1.7	3.05 (77.5)	15/16	0.58 (14.7)	0.15 (3.8)
1/2	-QTM8-BFL8-S	4.2	3.54 (89.9)	1 5/16	0.77 (19.6)	0.19 (4.8)
mm	—	—	mm (in.)	mm	mm (in.)	mm (in.)
6	-QTM4-BML6-S	0.9	77.5 (3.05)	24	11.7 (0.46)	3.8 (0.15)
10	-QTM4-BML10-S	1.7	77.7 (3.06)	24	16.8 (0.66)	3.8 (0.15)
12	-QTM8-BML12-S	4.2	89.9 (3.54)	35	19.6 (0.77)	4.8 (0.19)

Bodies

Tube Fitting

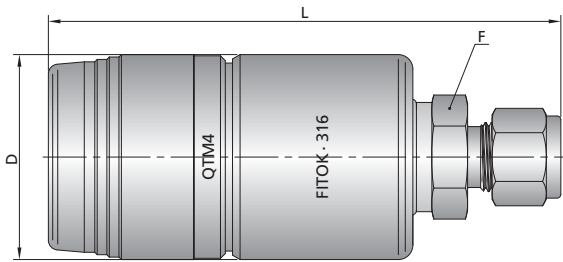

Fitting Size in.	Basic Ordering Number	Dimensions		
		L	D	F
		in. (mm)	in. (mm)	in.
1/4	-QTM2-FL4-B	3.16 (80.3)	1.12 (28.4)	9/16
1/4	-QTM4-FL4-B	4.17 (106)	1.68 (42.7)	7/8
3/8	-QTM2-FL6-B	3.25 (82.6)	1.12 (28.4)	3/4
3/8	-QTM4-FL6-B	4.17 (106)	1.68 (42.7)	7/8
1/2	-QTM8-FL8-B	4.30 (109)	2.00 (50.8)	1 1/8
3/4	-QTM8-FL12-B	4.30 (109)	2.00 (50.8)	1 1/8
1	-QTM8-FL16-B	4.58 (116)	2.00 (50.8)	1 3/8
mm			mm (in.)	mm
6	-QTM2-ML6-B	80.3 (3.16)	28.4 (1.12)	15
6	-QTM4-ML6-B	106 (4.17)	42.7 (1.68)	24
8	-QTM2-ML8-B	80.3 (3.16)	28.4 (1.12)	15
10	-QTM4-ML10-B	106 (4.17)	42.7 (1.68)	24
12	-QTM8-ML12-B	109 (4.30)	50.8 (2.00)	30

Female NPT

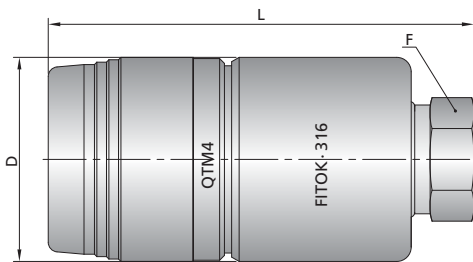

NPT Size in.	Basic Ordering Number	Dimensions		
		L	D	F
		in. (mm)	in. (mm)	in.
1/8	-QTM2-FNS2-B	2.60 (66.0)	1.12 (28.4)	9/16
1/4	-QTM2-FNS4-B	2.99 (75.9)	1.12 (28.4)	3/4
1/4	-QTM4-FNS4-B	3.35 (85.1)	1.68 (42.7)	7/8
3/8	-QTM2-FNS6-B	3.04 (77.2)	1.12 (28.4)	7/8
3/8	-QTM4-FNS6-B	3.35 (85.1)	1.68 (42.7)	7/8
1/2	-QTM8-FNS8-B	3.53 (89.7)	2.00 (50.8)	1 1/8
3/4	-QTM8-FNS12-B	4.02 (102)	2.00 (50.8)	1 5/16
1	-QTM8-FNS16-B	4.40 (112)	2.00 (50.8)	1 5/8

Female BSPT

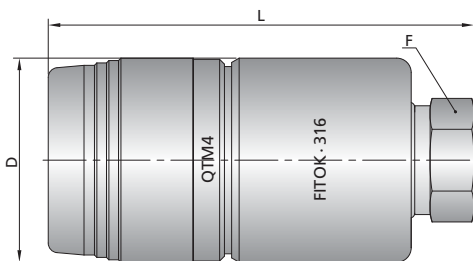

BSPT Size in.	Basic Ordering Number	Dimensions		
		L	D	F
		in. (mm)	in. (mm)	in.
1/8	-QTM2-FRT2-B	2.60 (66.0)	1.12 (28.4)	9/16
1/4	-QTM2-FRT4-B	2.99 (75.9)	1.12 (28.4)	3/4
1/4	-QTM4-FRT4-B	3.35 (85.1)	1.68 (42.7)	7/8
3/8	-QTM2-FRT6-B	3.04 (77.2)	1.12 (28.4)	7/8
3/8	-QTM4-FRT6-B	3.35 (85.1)	1.68 (42.7)	7/8
1/2	-QTM8-FRT8-B	3.53 (89.7)	2.00 (50.8)	1 1/8
3/4	-QTM8-FRT12-B	4.02 (102)	2.00 (50.8)	1 5/16
1	-QTM8-FRT16-B	4.40 (112)	2.00 (50.8)	1 5/8

Male NPT

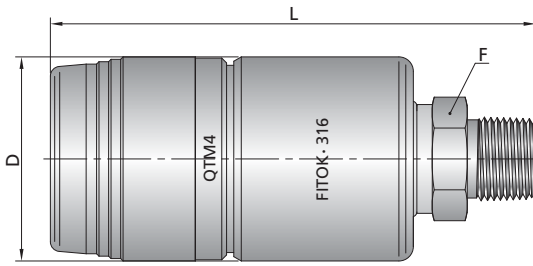

NPT Size in.	Basic Ordering Number	Dimensions		
		L in. (mm)	D in. (mm)	F in.
1/4	-QTM2-NS4-B	3.02 (76.7)	1.12 (28.4)	9/16
1/4	-QTM4-NS4-B	3.89 (98.8)	1.68 (42.7)	7/8
3/8	-QTM2-NS6-B	3.07 (78.0)	1.12 (28.4)	3/4
3/8	-QTM4-NS6-B	3.97 (100.8)	1.68 (42.7)	7/8
1/2	-QTM8-NS8-B	4.20 (107)	2.00 (50.8)	1 1/8
3/4	-QTM8-NS12-B	4.19 (106)	2.00 (50.8)	1 1/8
1	-QTM8-NS16-B	4.48 (114)	2.00 (50.8)	1 3/8

Male BSPT

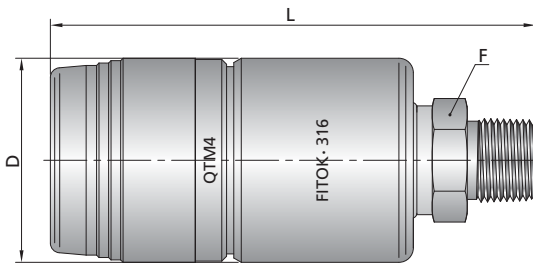

BSPT Size in.	Basic Ordering Number	Dimensions		
		L in. (mm)	D in. (mm)	F in.
1/4	-QTM2-RT4-B	3.02 (76.7)	1.12 (28.4)	9/16
1/4	-QTM4-RT4-B	3.89 (98.8)	1.68 (42.7)	7/8
3/8	-QTM2-RT6-B	3.07 (78.0)	1.12 (28.4)	3/4
3/8	-QTM4-RT6-B	3.97 (100.8)	1.68 (42.7)	7/8
1/2	-QTM8-RT8-B	4.20 (107)	2.00 (50.8)	1 1/8
3/4	-QTM8-RT12-B	4.19 (106)	2.00 (50.8)	1 1/8
1	-QTM8-RT16-B	4.48 (114)	2.00 (50.8)	1 3/8

Male JIC (AN) 37° Flare

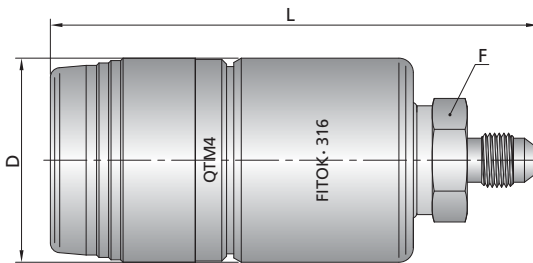

Fitting Size in.	Basic Ordering Number	Dimensions		
		L in. (mm)	D in. (mm)	F in.
1/4	-QTM4-AN4-B	3.89 (98.8)	1.68 (42.7)	7/8
1/2	-QTM8-AN8-B	4.20 (107)	2.00 (50.8)	1 1/8

Bulkhead Bodies

Bulkhead Tube Fitting

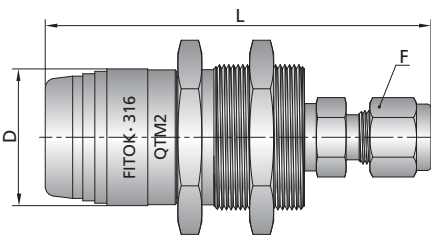
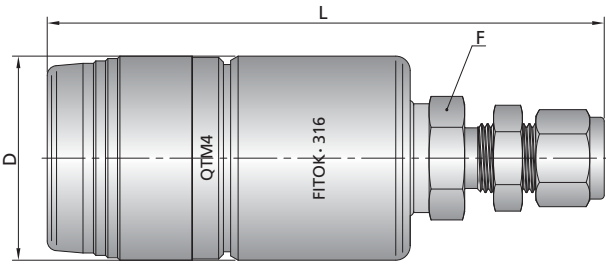

QTM2 Integral Bulkhead

Fitting Size	Basic Ordering Number	Dimensions			Min. Panel Orifice	Max. Panel Thickness
		L	D	F		
1/4 in.	-QTM2-BFL4-B	3.16 (80.3)	1.12 (28.4)	9/16	1.20 (30.6)	0.65 (16.5)
1/4 in.	-QTM4-BFL4-B	4.42 (112)	1.68 (42.7)	7/8	0.46 (11.7)	0.15 (3.8)
3/8 in.	-QTM4-BFL6-B	4.51 (115)	1.68 (42.7)	7/8	0.58 (14.7)	0.15 (3.8)
1/2 in.	-QTM8-BFL8-B	4.78 (121)	2.00 (50.8)	1 1/8	0.77 (19.6)	0.19 (4.8)
mm		mm (in.)	mm (in.)	mm	mm (in.)	mm (in.)
6	-QTM2-BML6-B	80.3 (3.16)	28.4 (1.12)	15	30.6 (1.20)	16.5 (0.65)
6	-QTM4-BML6-B	112 (4.42)	42.7 (1.68)	24	11.7 (0.46)	3.8 (0.15)
10	-QTM4-BML10-B	115 (4.52)	42.7 (1.68)	24	16.8 (0.66)	3.8 (0.15)
12	-QTM8-BML12-B	121 (4.77)	50.8 (2.00)	30	19.6 (0.77)	4.8 (0.19)

Bulkhead Male NPT

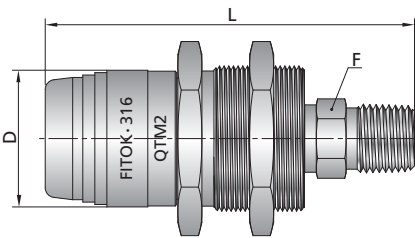

NPT Size	Basic Ordering Number	Dimensions			Min. Panel Orifice	Max. Panel Thickness
		L	D	F		
1/4 in.	-QTM2-BNS4-B	3.02 (76.7)	1.12 (28.4)	9/16	1.20 (30.6)	0.65 (16.5)

Bulkhead Male BSPT

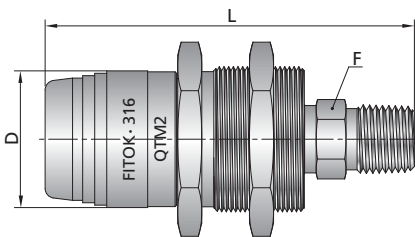

NPT Size	Basic Ordering Number	Dimensions			Min. Panel Orifice	Max. Panel Thickness
		L	D	F		
1/4 in.	-QTM2-BRT4-B	3.02 (76.7)	1.12 (28.4)	9/16	1.20 (30.6)	0.65 (16.5)

Bulkhead Female NPT

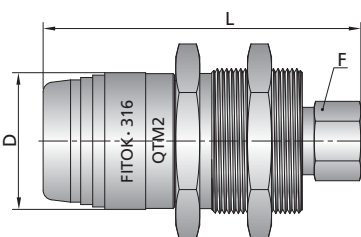

NPT Size	Basic Ordering Number	Dimensions			Min. Panel Orifice	Max. Panel Thickness
		L	D	F		
1/8 in.	-QTM2-BFNS2-B	2.60 (66.0)	1.12 (28.4)	9/16	1.20 (30.6)	0.65 (16.5)
1/4 in.	-QTM2-BFNS4-B	2.96 (75.2)	1.12 (28.4)	3/4	1.20 (30.6)	0.65 (16.5)

Bulkhead Female BSPT

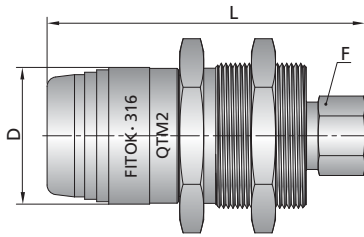

BSPT Size in.	Basic Ordering Number	Dimensions			Min. Panel Orifice in. (mm)	Max. Panel Thickness in. (mm)
		L in. (mm)	D in. (mm)	F in.		
1/8	-QTM2-BFRT2-B	2.60 (66.0)	1.12 (28.4)	9/16	1.20 (30.6)	0.65 (16.5)
1/4	-QTM2-BFRT4-B	2.96 (75.2)	1.12 (28.4)	3/4	1.20 (30.6)	0.65 (16.5)

Options, QTM Series

Keyed QTM Series

FITOK keyed quick-connects feature foolproof mechanical design to prevent accidental mixing of different working lines in actual working conditions.

Features

- Keyed quick-connects will not interchange with any other FITOK keyed quick-connects
- If an attempt is made to couple unlike keys, the valve system will not open
- Stems and bodies are color coded and numbered for easy identification



QTM Series Key Numbers

QTM2 and QTM4 series quick-connects are available in keys K1 through K8.

QTM8 series quick-connects are available in keys K1 through K4 only (black, orange, green, or yellow).

Each key number and the corresponding color are shown in "Ordering Number Description" below.

Ordering Number Description

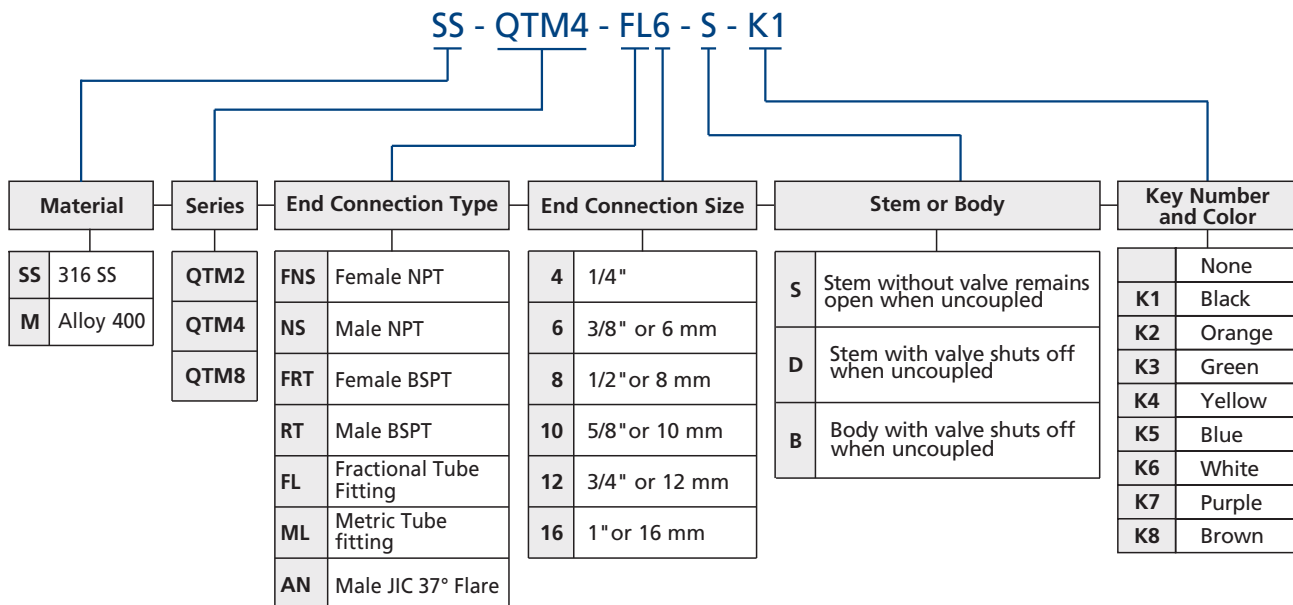

Note: 1. "Ordering Number Description" is a reference to understand the combination rules of FITOK product part number. Not all combinations are available.

2. Dimensions are for reference only and are subject to change.

info@fitokgroup.com
www.fitokgroup.com

FK-IC-GF-10-EN-200527

Sample Cylinders

Application

- ⦿ Hydrocarbon sampling for refineries
- ⦿ Gas sampling for chromatography experiments
- ⦿ Condensate sampling for fossil fuel and nuclear power plants
- ⦿ As surge accumulators or reaction vessels
- ⦿ As snubbers in reactor feed lines



Features

- ⦿ Capacities from 40 cm³ to 3785 cm³ (1 gal)
- ⦿ Spun cylinder body machined from seamless tubing to provide consistent wall thickness, size and capacity
- ⦿ Cold-formed female NPT thread to provide high strength
- ⦿ 1/8", 1/4" and 1/2" female NPT connections
- ⦿ Full-penetration gas tungsten arc-weld construction to ensure no leak for sampling (single-ended cylinder only)
- ⦿ DOT and non-DOT cylinders available
- ⦿ Accessories, such as valves, relief devices, outage tubes, carrying handles, caps and plugs available

Design

FITOK sample cylinders are designed and manufactured in compliance with 49 CFR, the stringent regulation of U.S. Department of Transportation, to provide high reliability and long service life.

Spun cylinders are made of seamless tubing to increase the wall thickness of neck transitions and thread areas which provides high strength to reduce the leak risks.

The cylinders are internal sandblasted to ensure smooth surface and minimized remaining particles for easy cleaning.

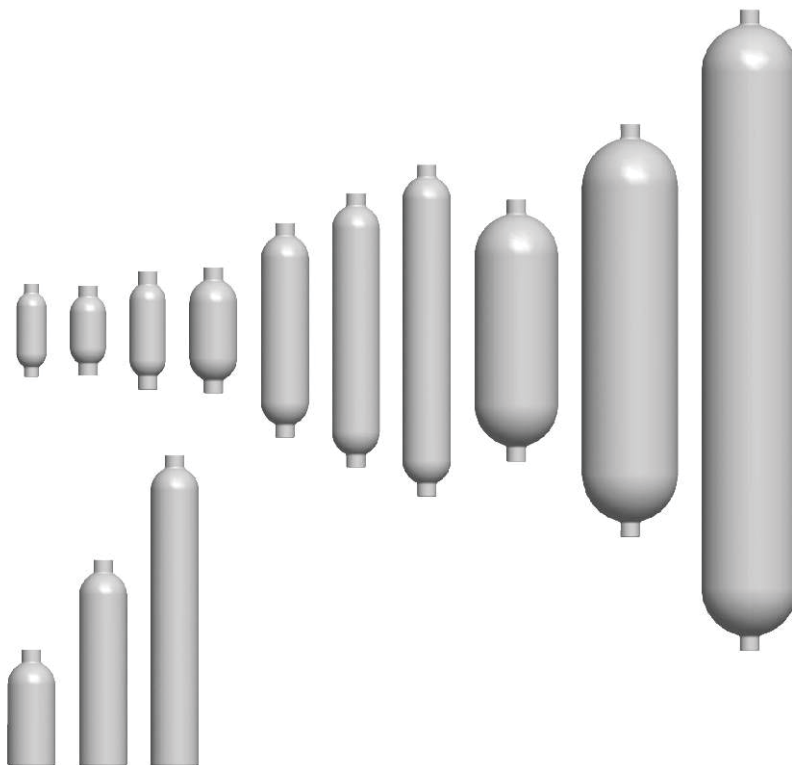

Materials

FITOK DOT cylinders are available in 304L SS and 316L SS. FITOK non-DOT cylinders are available in 304L SS, 316 L SS and Alloy 400. For cylinders of other materials, please contact FITOK Group or our authorized distributors.

Pressure - Temperature

Material	316L SS	316L SS, 304L SS	304L SS	Alloy 400	316 SS	304L SS
DOT Specification	DOT-3A 5000 TC-3ASM 344	DOT-3E 1800 TC-3EM 124	DOT-3A 1800 TC-3ASM 124	—	—	—
Temperature, °F (°C)	Working pressure, psig (bar)					
-65 (-53) to 100 (37)	5000 (344)	1800 (124)	1800 (124)	1800 (124)	1000 (69.0)	500 (34.4)
200 (93)	3960 (272)	1360 (93.7)	1360 (93.7)	1580 (108)	840 (57.8)	500 (34.4)
300 (148)	3570 (245)	1230 (84.7)	1230 (84.7)	1490 (102)	760 (52.3)	500 (34.4)
400 (204)	3290 (226)	1130 (77.8)	1130 (77.8)	1430 (98.5)	700 (48.2)	500 (34.4)
500 (260)	3060 (210)	1050 (72.3)	1050 (72.3)	1420 (97.8)	650 (44.7)	500 (34.4)
600 (315)	2920 (201)	1000 (69.0)	1000 (69.0)	1420 (97.8)	620 (42.7)	500 (34.4)
650 (343)	2870 (197)	980 (67.5)	980 (67.5)	1420 (97.8)	610 (42.0)	500 (34.4)
700 (371)	2810 (193)	970 (66.8)	970 (66.8)	1420 (97.8)	590 (40.6)	500 (34.4)
750 (398)	2750 (189)	950 (65.4)	950 (65.4)	1410 (97.1)	580 (39.9)	500 (34.4)
800 (426)	2700 (186)	930 (64.0)	930 (64.0)	—	570 (39.2)	500 (34.4)
850 (454)	2640 (181)	—	—	—	560 (38.5)	—

Notes:

1. Working temperature is limited to 300°F (148°C) maximum for cylinders with PTFE internal coating.
2. Working pressure and temperature may be restricted by individual local government regulations.

Testing

Single-ended Cylinders

All single-ended cylinders are hydrostatically tested at 1000 psig (69 bar).

Double-ended Cylinders

All double-ended cylinders are hydrostatically tested to at least 5/3 times the working pressure.

DOT-3A 1800 cylinders are hydrostatically tested at 3000 psig (206 bar) minimum .

DOT-3E 1800 cylinders are hydrostatically tested at 3050 psig (210 bar).

DOT-3A 5000 cylinders are hydrostatically tested at 8500 psig (586 bar) minimum.

Transportable Pressure Equipment Directive (TPED)

The Transportable Pressure Equipment Directive (TPED) provides requirements for the design, manufacturing, and testing of transportable pressure vessels and accessories, including sample cylinders and rupture discs. The directive aims to provide a uniform level of product safety throughout the European Union countries.

For information about FITOK TPED-compliant products, please refer to FITOK Catalog *Sample Cylinders Compliant with the Transportable Pressure Equipment Directive (TPED)*.

Technical Data

Dimensions are for reference only and are subject to change.

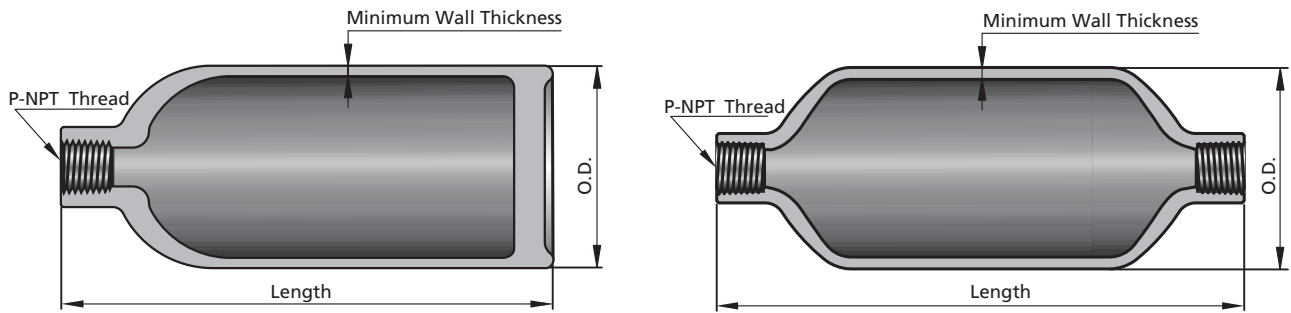

Material Grade/Cylinder Specification	Pressure Rating psig (bar)	Cylinder Volume (cm ³ ±10%)	P in.	Dimensions, in. (mm)			Weight lb (kg)
				O.D.	Length	Minimum Wall Thickness	
Single-ended							
304L SS/	500 (34.4)	150	1/4	2.00 (50.8)	4.88 (124)	0.093 (2.4)	1.10 (0.50)
		300			8.62 (219)		1.80 (0.82)
		500			13.6 (345)		2.70 (1.2)
Double-ended							
304L SS/ DOT-3E 1800	1800 (124)	40	1/8	1.25 (31.8)	3.88 (98.6)	0.070 (1.8)	0.31 (0.14)
		50	1/4	1.5 (38.1)	3.75 (95.2)		0.38 (0.17)
		75			4.94 (125)	0.62 (0.28)	
		150 ^①	1/4	2.00 (50.8)	5.25 (133)	0.093 (2.4)	0.94 (0.43)
		290			8.86 (225)		1.79 (0.81)
		300 ^①			8.94 (227)		1.80 (0.83)
		400			11.4 (290)		2.10 (0.95)
		500 ^①			13.8 (351)		2.61 (1.20)
304L SS/ DOT-3A 1800	1800 (124)	1000 ^①	1/4 or 1/2	3.50 (88.9)	10.9 (277)	0.180 (4.6)	6.50 (2.90)
		2250 ^①	1/4 or 1/2	4.00 (102)	17.2 (437)	0.206 (5.2)	14.00 (6.40)
		3785 ^① (1 gal)			26.7 (678)		21.00 (9.50)
316L SS/ DOT-3E 1800	1800 (124)	150 ^①	1/4	2.00 (50.8)	5.25 (133)	0.093 (2.4)	0.94 (0.43)
		290			8.86 (225)		1.79 (0.81)
		300 ^①			8.94 (227)		1.80 (0.83)
		500 ^①			13.8 (351)		2.60 (1.20)
316L SS/ DOT-3A 5000	5000 (344)	150 ^①	1/4	1.90 (48.2)	8.00 (203)	0.240 (6.1)	3.00 (1.40)
		300 ^①			14.5 (368)		5.60 (2.50)
		500 ^①			23.5 (597)		9.10 (4.10)
Alloy 400	1800 (124)	150	1/4	2.00 (50.8)	5.25 (133)	0.093 (2.4)	0.94 (0.43)
		300			8.94 (227)		1.80 (0.82)
		500			13.8 (351)		2.90 (1.30)

^① DOT cylinders are available.

TC certified sample cylinders are also available upon request. For more information, please contact FITOK Group or our authorized distributors.

Options for Internal Cylinder Surface Treatments

PTFE Coating

The internal cylinder surface can be coated with PTFE to provide a nonstick surface for easy cleaning.

Electropolishing

Electropolishing can provide a clean internal surface with a high degree of passivation.

Cleaning and Packaging

All FITOK sample cylinders and cylinder valves are cleaned and packaged in accordance with FITOK *FC-01 Standard Cleaning and Packaging*.

FITOK *FC-02 Special Cleaning and Packaging* in compliance with the requirements of ASTM G93 Level C is optional.

Overpressure Protection

Cylinders for compressed air must be equipped with pressure relief devices in accordance with US DOT regulations and CGA Pamphlet S-1.1. The CGA Pamphlet lists devices that can be used with specific gases. It also contains information on other types of pressure relief devices.

- ▲ Be sure to use the correct pressure relief device for the gas being used.
- ▲ Proper filling of the cylinder according to DOT specifications or other local regulations, is critical in preventing overpressurization.

Rupture Disc Kits

Rupture disc kits protect sample cylinder from overpressurization by venting the gas to atmosphere. The rupture disc kits are used to be installed in valves or rupture disc tees and sealed by O-rings. The rupture disc kits can be easily replaced without removing valves or tees from cylinders.

Materials of Construction

Component	Material Grade/ASTM Specification
Body, inlet ring	316 SS/A479
Rupture disc	Alloy 600/B168
O-ring	Fluorocarbon FKM



Ordering Information

Nominal Burst Pressure at 70°F (20°C)	Ordering Number
2850 psig ± 150 psig 196 bar ± 10.3 bar	SS-RDD-7BS-2850
1900 psig ± 100 psig 130 bar ± 6.8 bar	SS-RDD-7BS-1900

Note: The rupture disc kits should be used with FITOK Rupture Disc Tees.

Rupture Disc Tees

These compact assemblies are designed for using with FITOK valves. Tees are made of 316 SS. Each tee is supplied with a rupture disc kit.

Ordering Information and Dimensions

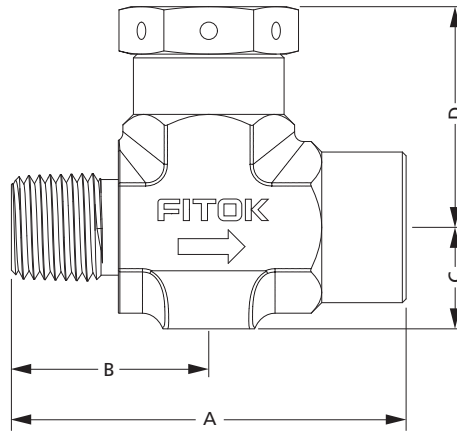

End Connections		Ordering Number	Dimensions, in. (mm)			
Inlet	Outlet		A	B	C	D
With 2850 psig (196 bar) Rupture Disc						
1/4 in. Male NPT	1/4 in. Female NPT	SS-TM4-F4-RD28	2.06 (52.4)	1.03 (26.2)	0.53 (13.5)	1.16 (29.4)
1/2 in. Male NPT		SS-TM8-F4-RD28	2.63 (66.7)	1.50 (38.1)	0.75 (19)	1.42 (36)
With 1900 psig (130 bar) Rupture Disc						
1/4 in. Male NPT	1/4 in. Female NPT	SS-TM4-F4-RD19	2.06 (52.4)	1.03 (26.2)	0.53 (13.5)	1.16 (29.4)
1/2 in. Male NPT		SS-TM8-F4-RD19	2.63 (66.7)	1.50 (38.1)	0.75 (19)	1.42 (36)

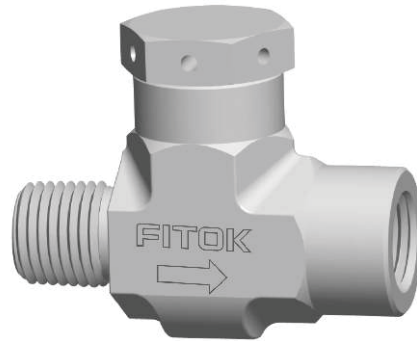

Nonrotating-stem Needle Valves with Rupture Disc Kits

Ordering Information and Dimensions

End Connections		Flow Pattern	Valve Ordering Number	Orifice in. (mm)
Inlet	Outlet			
With 2850 psig (196 bar) Rupture Disc				
1/4 in. Male NPT	1/4 in. Female NPT	Straight	NDSS-NS4-FNS4-7-SAFE2	0.16 (4.0)
			NDSS-NS4-FNS4-7-A-SAFE2	
1/2 in. Male NPT	1/4 in. Female NPT	Angle	NDSS-NS8-FNS4-8-A-SAFE2	0.22 (5.6)
With 1900 psig (130 bar) Rupture Disc				
1/4 in. Male NPT	1/4 in. Female NPT	Straight	NDSS-NS4-FNS4-7-SAFE1	0.16 (4.0)
			NDSS-NS4-FNS4-7-A-SAFE1	
1/2 in. Male NPT	1/4 in. Female NPT	Angle	NDSS-NS8-FNS4-8-A-SAFE1	0.22 (5.6)

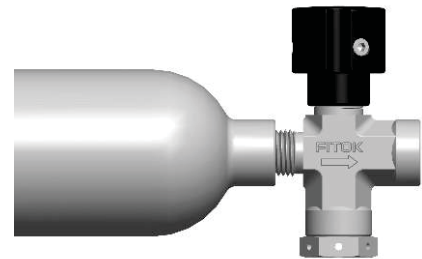

1. Dimensions are for reference only and are subject to change.
2. Other FITOK valves are available for using with sample cylinders. Please contact FITOK Group or our authorized distributors for details.

Spring Relief Devices

Introduction

- ⦿ Spring relief devices can be used with FITOK sample cylinders as a safety device.
- ⦿ When the system pressure reaches the set pressure, the device will open automatically to release the excess pressure in the system. After stabilizing the system pressure, the device will close automatically.



Working Temperature

-20°F~250°F (-29°C~121°C)

Materials of Construction

Item	Component	Material Grade/ASTM Specification
1	Body	316 SS/A182
2	Gasket	PCTFE/D1430
3	Seat	316 SS/A479
4	Stem	316 SS/A479+Fluorocarbon FKM
5	Spring	304 SS/A313
6	Bonnet	316 SS/A479

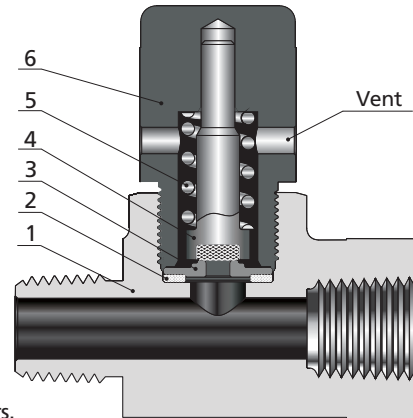

1. Lubricant: Silicone-based.
2. For other materials, please contact FITOK Group or our authorized distributors.

Dimensions and Ordering Information

All dimensions are for reference only and are subject to change.

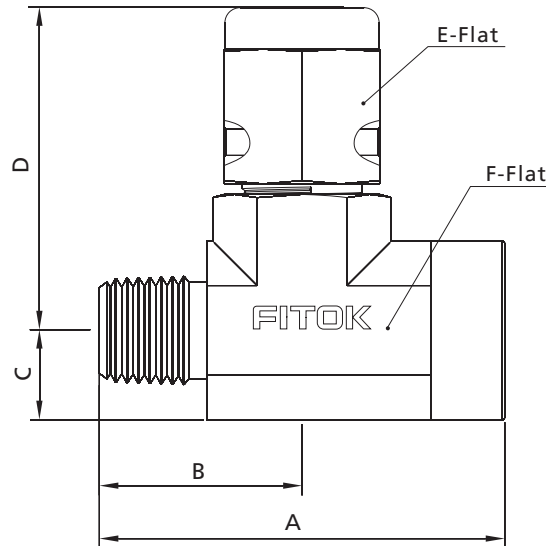

Basic Ordering Number	Connection Type and Size		Dimensions, in. (mm)						Set Pressure, psig (bar)
	Inlet	Outlet	A	B	C	D	E	F	
RTSS-NS4-FNS4-4	1 / 4 Male NPT	1 / 4 Female NPT	2.11 (53.6)	1.05 (26.8)	0.46 (11.7)	1.68 (42.7)	0.81 (20.6)	0.81 (20.6)	350 ~ 400 (24~27)
RTSS-NS4-FNS4-6									540 ~ 600 (37~41)
RTSS-NS4-FNS4-8									700 ~ 800 (48~55)
RTSS-NS6-FNS4-4	3 / 8 Male NPT								350 ~ 400 (24~27)
RTSS-NS6-FNS4-6									540 ~ 600 (37~41)
RTSS-NS6-FNS4-8									700 ~ 800 (48~55)

For other set pressures, please contact FITOK Group or our authorized distributors.

Sample Cylinder Accessories

Carrying Handle

The carrying handle provides convenience for transportation of sample cylinders. The handle is made of 304 SS and is available for 290 cm³ cylinders or larger cylinders.

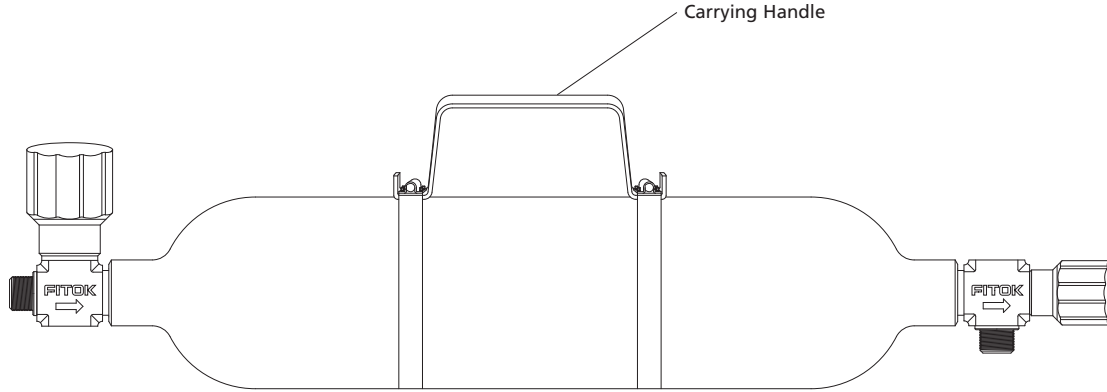

Ordering Information

Cylinder OD in. (mm)	Cylinder Volume cm ³	Ordering Number
1.9 (48.2)	290~500	HD-CY2-H2
2.0 (50.8)		
3.5 (88.9)	1000	HD-CY3-H2
4.0 (102)	2250/3785	HD-CY4-H4

Caps and Plugs

Caps and plugs are used for cylinder valves to protect the connections (tube fitting or NPT thread) from damages during cylinder transportation. For details, please contact FITOK Group or our authorized distributors.

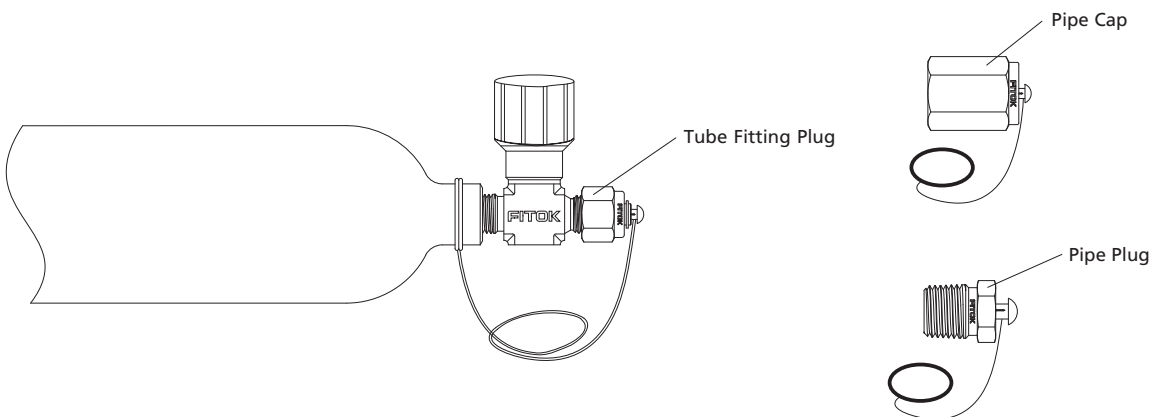

End Caps

In order to enable users to transport pressurized samples in safety, end caps are offered by FITOK to protect valves from damages. Each end cap is screwed onto a neck ring that has been cold forged to the cylinder neck. End caps are made of carbon steel and are only available for 2250 cm³ and 3785 cm³ (1 gal) cylinders . FITOK angle pattern valves can be used for cylinders with end caps.

Note: Double-ended cylinders with end caps on both ends are standard configurations.



Outage Tubes

Features

- ⦿ 316 SS and Alloy 400 available
- ⦿ 1/4" and 1/2" NPT connections available

Construction

Outage tube is welded to the male thread end of an adapter. Screw the adapter with outage tube into the female thread end of a sample cylinder.

Purpose

The outage tube provides a vapor space of desired volume in a cylinder with liquefied gas. Therefore, liquids can expand when the temperature increases. A small temperature increase can make the liquids expanded and the pressure increased dramatically if there is not enough vapor space.

Note: For safe filling limits of your application, please refer to local regulations or other guidelines.

Usage

Outage tube is used to keep a certain vapor space in a cylinder. The space is determined by the length of outage tube. Outage is the vapor space in the cylinder expressed as a percentage of the total volume of the cylinder.

$$\% \text{ outage} = (\text{vapor space} / \text{total volume}) \times 100$$

To obtain an exact outage, each outage tube and cylinder assembly should be calibrated by a suitable method.

Outage Tube Length

The outage tube length (L) is measured from the end of the pipe fitting to the end of the tubing. The table below shows approximate outage tube length for standard sample cylinders.

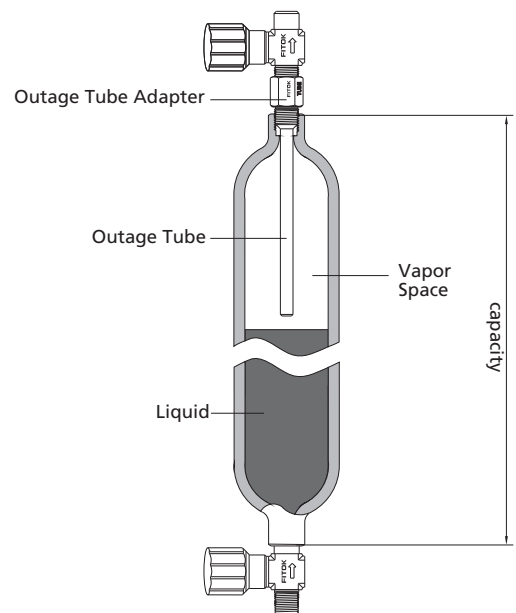

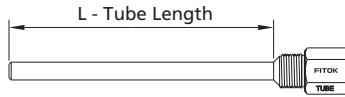

Tube of desired length is available upon request.

Tube O.D.	Cylinder Volume (cm ³ ±10%)	Code	Minimum Outage, %					
			10	20	30	40	50	
			Tube Length, in.					
1/4"	40	Applicable to double-ended cylinders rated to 1800 psig	4087	0.87	1.11	1.35	1.59	1.84
	50		5085	0.85	1.07	1.28	1.50	1.71
	75		5102	1.02	1.34	1.66	1.98	2.31
	150		5112	1.12	1.45	1.79	2.13	2.46
	300		5165	1.65	2.32	2.99	3.67	4.34
	400		5200	2.00	2.90	3.79	4.69	5.59
	500		5226	2.26	3.38	4.50	5.62	6.74
	1000		5231	2.31	3.06	3.81	4.56	5.31
	2250		5717	3.30	4.59	5.88	7.17	8.46
	3785 (1 gal)		51114	4.62	6.79	8.96	11.14	13.31
1/2"	1000	Applicable to double-ended cylinders rated to 1800 psig	8221	2.21	2.96	3.71	4.46	5.21
	2250		8846	3.30	4.59	5.88	7.17	8.46
	3785 (1 gal)		8452	4.52	6.69	8.86	11.04	13.21
5/16"	150	Applicable to single-ended cylinders rated to 500 psig	5109	1.09	1.43	1.77	2.12	2.46
	300		5159	1.59	2.27	2.96	3.65	4.34
	500		5560	2.16	3.30	4.45	5.60	6.74
	150	Applicable to double-ended cylinders rated to 5000 psig	5162	1.62	2.17	2.71	3.26	3.81
	300		5274	2.74	3.84	4.93	6.03	7.12
	500		5439	4.39	6.21	8.04	9.86	11.68

For the use of sample cylinder and outage tube, please refer to ASTM D1265, *Standard Practice for Sampling Liquefied Petroleum (LP) Gases, Manual Method*.

Ordering Number Description

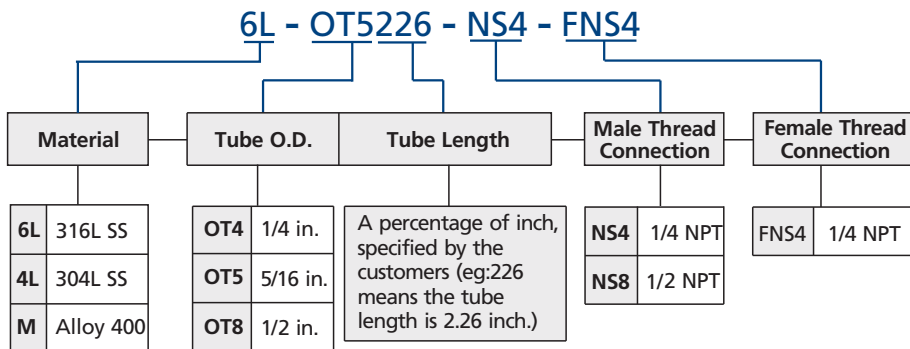

Note: "Ordering Number Description" is a reference to understand the combination rules of FITOK product part number. Not all combinations are available.

Ordering Number Description

6L - SC18 - DN4 - T - EC - H2 - OT4087 - 300 - DOT - F2

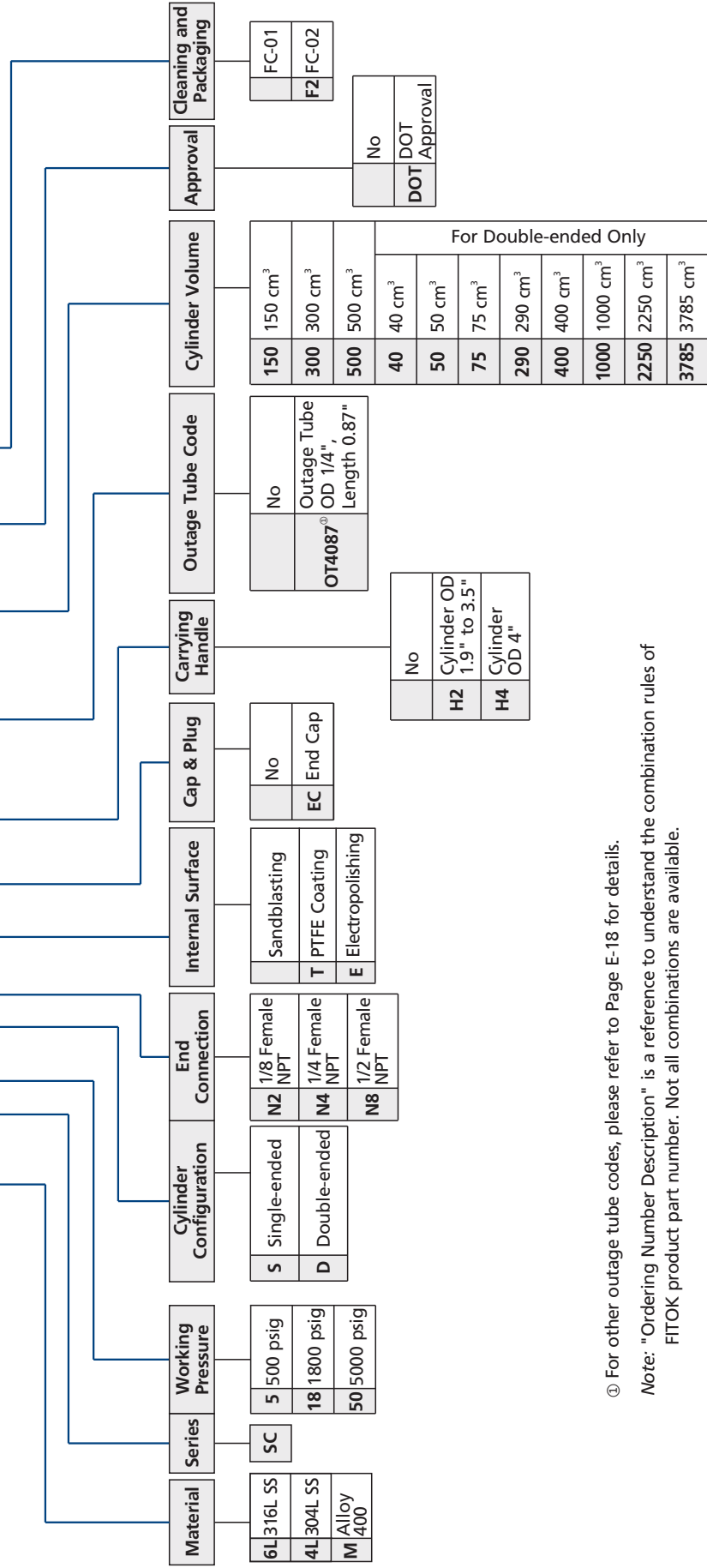

① For other outage tube codes, please refer to Page E-18 for details.

Note: "Ordering Number Description" is a reference to understand the combination rules of FITOK product part number. Not all combinations are available.

Miniature Sample Cylinders

Features

- Maximum working pressure: 1000 psig (69.0 bar)
- Capacities: 10, 25 and 50 cm³
- Single-ended and double-ended configurations available
- Smooth internal neck transition for easy cleaning
- Stainless steel construction to ensure high corrosion resistance
- Full-penetration butt weld constructions

Dimensions

Dimensions, in inches (millimeters), are for reference only and are subject to change.

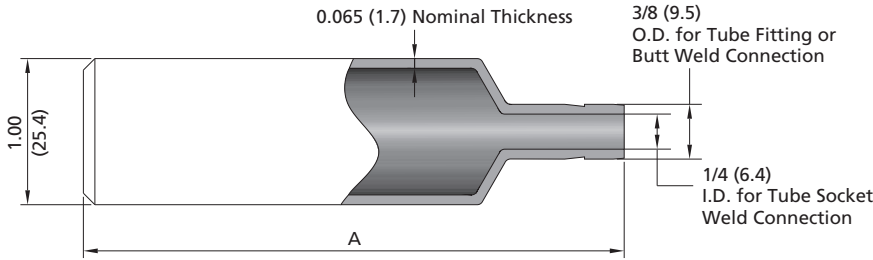

Cylinder Configuration	Cylinder Volume cm ³	Volume Tolerance	Working Pressure psig (bar)	A in. (mm)	Average Weight oz (g)
Single-ended	10	±10%	1000 (69.0)	2.19 (55.6)	2.2 (62)
	25	±5%		3.69 (93.7)	3.2 (91)
	50			6.25 (159)	5.6 (159)
Double-ended	10	±10%		2.75 (69.8)	1.9 (54)
	25	±5%		4.25 (108)	3.3 (94)
	50			6.81 (173)	5.1 (145)

Testing and Cleaning

Each miniature cylinder is pressure tested at 1667 psig (115 bar) with Nitrogen. Special Cleaning and Packaging in compliance with ASTM G93 Level C is optional.

Cautions

- No impingement during the usage of the cylinders.
- Don't expose the cylinders in the sun or bake next to the heat source.
- Sample cylinders are strictly prohibited roasting by fire when the cylinders are frozen.
- When using the sample cylinders, the working pressure should not exceed its maximum allowable working pressure.

Ordering Number Description

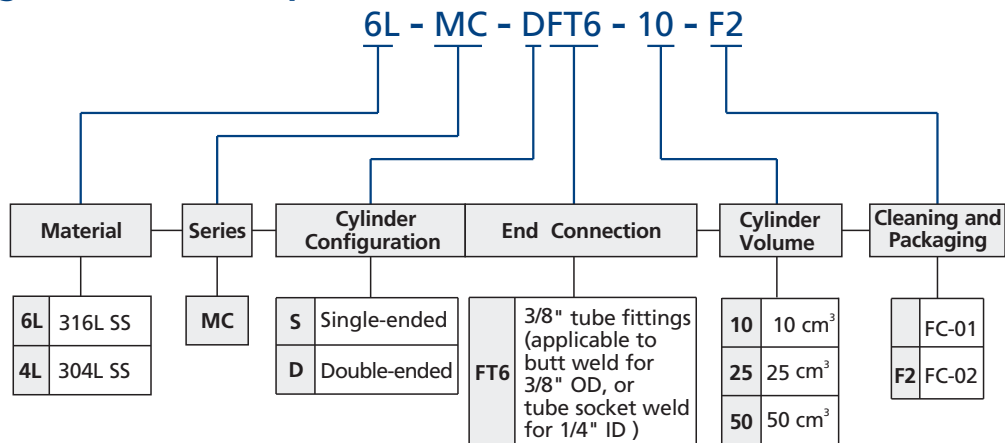

TPED-compliant Cylinder Valves



FITOK

Contents

TPED-compliant Cylinder Valves 01

Application 01

Test 01

Pi (Π) Making 01

ND Series Cylinder Valves 01

NU Series Cylinder Valves 05

TPED-compliant Cylinder Valves

FITOK cylinder valves have been designed, manufactured, documented and tested in accordance with the requirements of the Transportable Pressure Equipment Directive 2010/35/EU. This directive sets out detailed rules concerning transportable pressure equipment to enhance safety and ensure free movement of such equipment within the European Union. FITOK cylinder valves comply with the Transportable Pressure Equipment Directive 2010/35/EU (TPED), and have been approved by a notified body, and acquired EC Type Approval Certificate.

Application

FITOK TPED-compliant cylinder valves apply to compressed, liquefied or dissolved gases except acetylene, oxygen or oxidizing gas. In addition, they are not suitable for cryogenic equipment, portable fire extinguishers, liquefied and petroleum gas (LPG), and cannot be used as quick-release valves (e.g. for fire-extinguishing, explosion protection and rescue application).

Test

Every FITOK TPED-compliant cylinder valve has been subjected to both internal leak tightness and external leak tightness test with nitrogen or compressed air at 1.2 times of rated working pressure prior to dispatch. The TPED-compliant cylinder valves have a maximum allowable internal and external leakage rate of 6 std cm³/h.

Pi (Π) Making

Every FITOK TPED-compliant cylinder valve has been Pi-marked and the identification number of the notified body involved in the initial inspections and tests.

ND Series Cylinder Valves



Features

- ⦿ One-piece forged body
- ⦿ Compact design
- ⦿ Non-rotating stem
- ⦿ Soft tip design to seal easily
- ⦿ Special designed handle to stop contamination from entering into the valve

Technical Data

Rated working temperature	Rated working pressure	Flow coefficient Cv
-4~150 °F (-20~65°C)	2500 psig (172 bar)	0.53

Standard Materials Of Construction

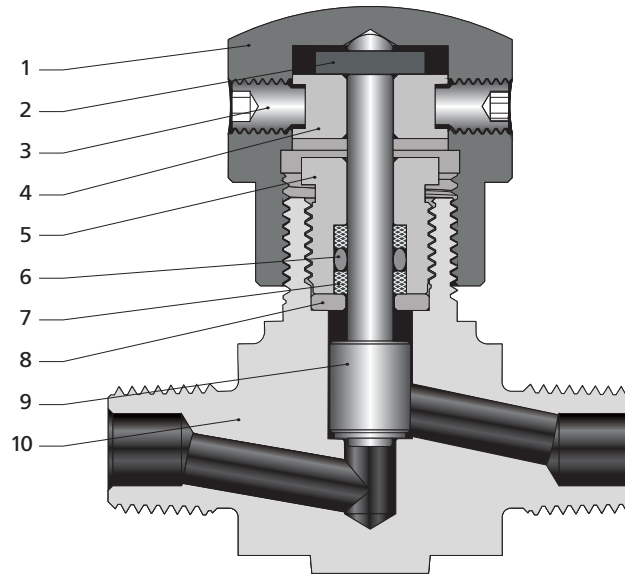

Item	Component	Valve Material 316 SS
		Material Grade/ASTM Specification
1	Handle	C36000/B16
2	Stop Pin	Stainless Steel
3	Set Screw	Steel
4	Spool	Aluminum
5	Packing Bolt	316SS/A479
6	<i>O-Ring</i>	Buna-N(NBR) or Ethylene Propylene Diene Monomer (EPDM)
7	<i>Backup Ring</i>	PTFE/D1710
8	<i>Washer</i>	316SS/A479
9	<i>Stem</i>	316SS/A479
	<i>Stem Tip</i>	PEEK
10	<i>Body</i>	316SS/A182
	Lubricant	thread: Molybdenum disulfide-based O-ring: silicon-based

Note: Wetted components listed in italics.

Dimensions

Straight Pattern

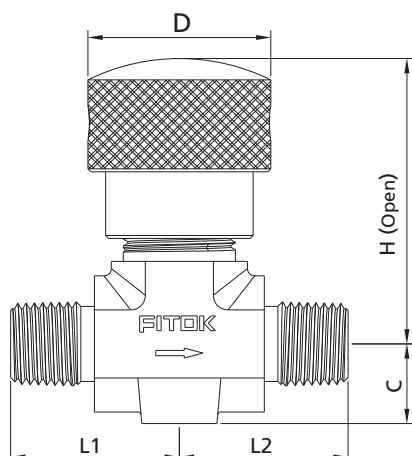

Angle Pattern

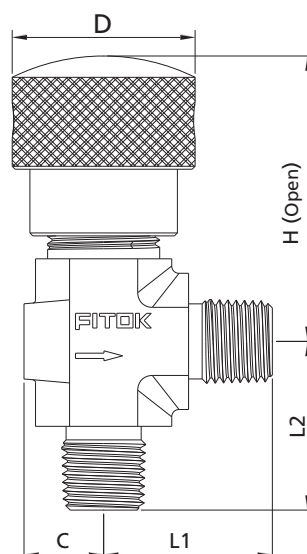

Basic Ordering Number		Connection Type and Size		Orifice in.(mm)	Dimensions, in.(mm)				
Buna N O-Ring	Ethylene Propylene O-Ring	Inlet	Outlet		L1	L2	C	D	H
NDSS-FNS4-8PB-TGCV NDSS-FNS4-8PB-A-TGCV	NDSS-FNS4-8PE-TGCV NDSS-FNS4-8PE-A-TGCV	1/4 Female NPT	1/4 Female NPT	0.22 (5.6)	1.06 (26.9)		0.53 (13.5)	1.22 (31)	2.04 (51.8)
NDSS-NS4-8PB-TGCV NDSS-NS4-8PB-A-TGCV	NDSS-NS4-8PE-TGCV NDSS-NS4-8PE-A-TGCV	1/4 Male NPT	1/4 Male NPT		1.13 (28.6)				
NDSS-NS6-8PB-TGCV NDSS-NS6-8PB-A-TGCV	NDSS-NS6-8PE-TGCV NDSS-NS6-8PE-A-TGCV	3/8 Male NPT	3/8 Male NPT		1.32 (33.5)				
NDSS-NS4-FNS4-8PB-TGCV NDSS-NS4-FNS4-8PB-A-TGCV	NDSS-NS4-FNS4-8PE-TGCV NDSS-NS4-FNS4-8PE-A-TGCV	1/4 Male NPT	1/4 Female NPT		1.13 (28.6)	1.29 (32.8)	0.53 (13.5)	2.04 (51.8)	
NDSS-NS8-FNS4-8PB-TGCV NDSS-NS8-FNS4-8PB-A-TGCV	NDSS-NS8-FNS4-8PE-TGCV NDSS-NS8-FNS4-8PE-A-TGCV	1/2 Male NPT	1/4 Female NPT		1.29 (32.8)				
NDSS-NS4-FL6-8PB-TGCV NDSS-NS4-FL6-8PB-A-TGCV	NDSS-NS4-FL6-8PE-TGCV NDSS-NS4-FL6-8PE-A-TGCV	1/4 Male NPT	3/8 in. FITOK						
NDSS-FL6-8PB-TGCV NDSS-FL6-8PB-A-TGCV	NDSS-FL6-8PE-TGCV NDSS-FL6-8PE-A-TGCV	3/8 in. FITOK	3/8 in. FITOK						

1. Connection type of "FITOK" means FITOK double ferrule tube fittings. When the connection type of valves is FITOK double ferrule tube fitting, the working pressures of the valves are related to the wall thickness of the tubing applied. For specific working pressure of the valves, please refer to the allowable working pressure in FITOK Catalog *Tubing*.
2. Sizes and types listed are standard.
3. Dimensions are shown with FITOK tube fitting nuts finger-tight. All dimensions are for reference only and are subject to change. For dimensions not shown above, please contact FITOK Group or our authorized distributors.

Ordering Number Description

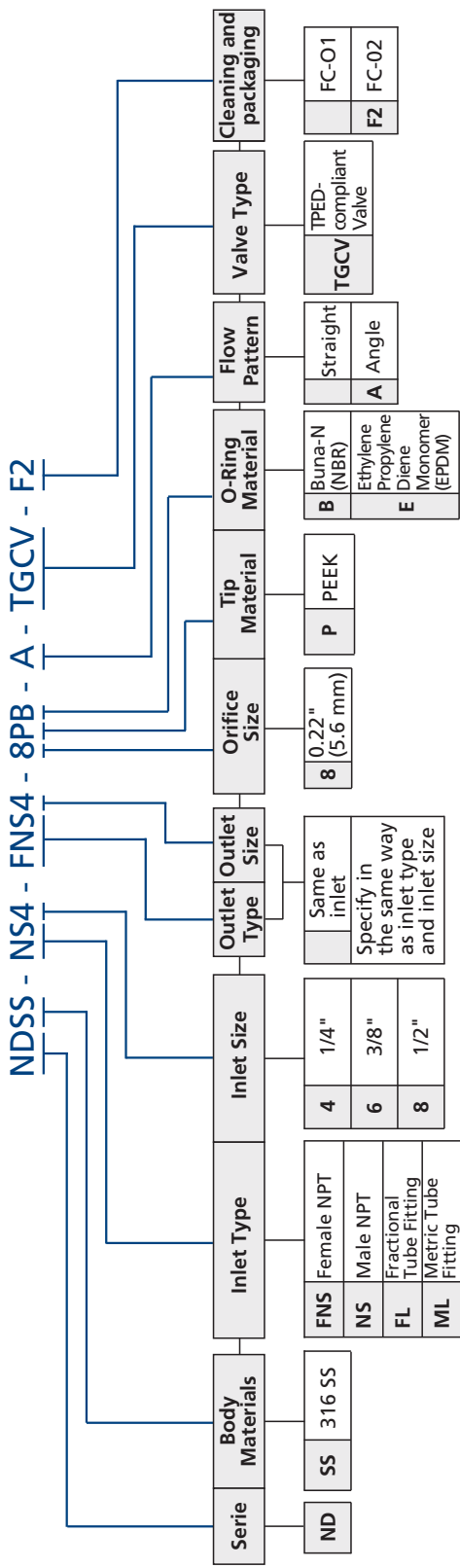

Note: "Ordering Number Description" is a reference to understand the combination rules of FITOK product part number. Not all combination is available. If any questions, please contact FITOK Group or our authorized distributors.

1. Cleaning and Packing:
 FC-01: Standard cleaning and packaging for general industrial procedures.
 FC-02: Special cleaning and packaging for wetted system components to ensure compliance with product cleanliness requirement of ASTM G93 Level C.

NU Series Cylinder Valves



Features

- ⦿ One-piece forged body
- ⦿ Simple stem to operate stably
- ⦿ Soft tip design to seal easily
- ⦿ Safety back seating seal in the fully open position
- ⦿ Union bonnet construction to avoid accidental valve disassembly
- ⦿ Stem thread lubricant isolated from system media
- ⦿ Panel mounting available

Technical Data

Rated working temperature	Rated working pressure	Flow coefficient Cv
-4~150 °F (-20~65°C)	5000 psig (345 bar)	0.35

Standard Materials of Construction

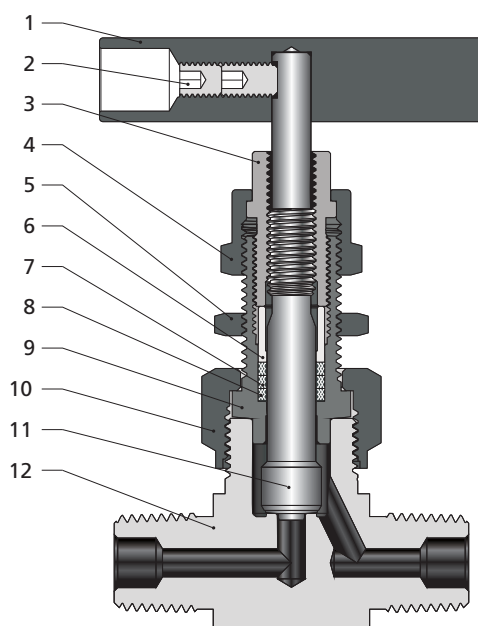

Item	Component	Valve Material 316 SS
		Material Grade/ASTM Specification
1	Handle	Stainless Steel
2	Set Screw	Steel
3	Packing Bolt	304SS/A479
4	Lock Nut	304SS/A479
5	Panel Nut	316SS/A479
6	Gland	316SS/A479
7	<i>Packing</i>	PEEK
8	<i>Packing Washer</i>	PEEK
9	<i>Bonnet</i>	316SS/A479
10	Union Nut	316SS/A479
11	<i>Stem</i>	316SS/A479
	<i>Stem Tip</i>	PEEK
12	<i>Body</i>	316/A182
	Lubricant	Molybdenum disulfide-based

Note: Wetted components listed in italics.

Dimensions

Straight Pattern

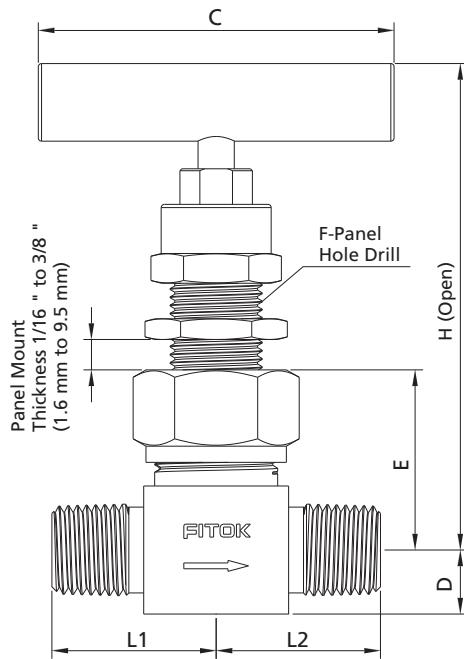

Angle Pattern

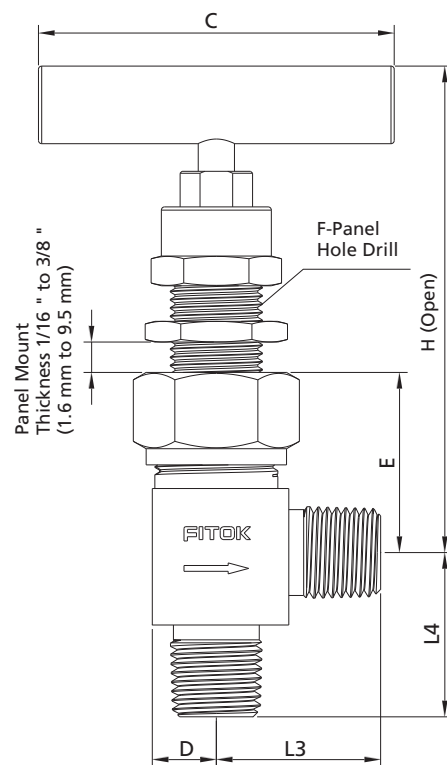

Basic Ordering Number	Connection Type and Size		Orifice in.(mm)	Dimensions, in.(mm)									
	Inlet	Outlet		L1	L2	L3	L4	C	D	E	F	H	
NUSS-FNS2-7P-PM-TGCV NUSS-FNS2-7P-PM-A-TGCV	1/8 Female NPT	1/8 Female NPT	0.16 (4.0)	1.00 (25.4)		0.85 (21.6)	1.00 (25.4)	2.17 (55)	0.39 (9.9)	1.1 (27.9)	0.59 (15)	3.08 (78.2)	
NUSS-FNS4-7P-PM-TGCV NUSS-FNS4-7P-PM-A-TGCV	1/4 Female NPT	1/4 Female NPT		1.03 (26.2)									
NUSS-NS4-7P-PM-TGCV NUSS-NS4-7P-PM-A-TGCV	1/4 Male NPT	1/4 Male NPT		1.00 (25.4)		1.00 (25.4)							
NUSS-NS4-FNS4-7P-PM-TGCV NUSS-NS4-FNS4-7P-PM-A-TGCV	1/4 Male NPT	1/4 Female NPT		1.00 (25.4)	1.03 (26.2)	0.85 (21.6)							
NUSS-RT4-FRT4-7P-PM-TGCV NUSS-RT4-FRT4-7P-PM-A-TGCV	R 1/4 Male BSPT	R 1/4 Female BSPT											
NUSS-FL4-7P-PM-TGCV NUSS-FL4-7P-PM-A-TGCV	1/4 in. FITOK	1/4 in. FITOK				1.14 (29)							
NUSS-ML6-7P-PM-TGCV NUSS-ML6-7P-PM-A-TGCV	6 mm FITOK	6 mm FITOK		1.22 (30.9)		1.16 (29.5)							1.22 (30.9)
NUSS-ML8-7P-PM-TGCV NUSS-ML8-7P-PM-A-TGCV	8 mm FITOK	8 mm FITOK				1.17 (29.7)							

1. Connection type of "FITOK" means FITOK double ferrule tube fittings. When the connection type of valves is FITOK double ferrule tube fitting, the working pressures of the valves are related to the wall thickness of the tubing applied. For specific working pressure of the valves, please refer to the allowable working pressure in FITOK Catalog *Tubing*.
2. Sizes and types listed are standard.
3. Dimensions are shown with FITOK tube fitting nuts finger-tight. All dimensions are for reference only and are subject to change. For dimensions not shown above, please contact FITOK Group or our authorized distributors.

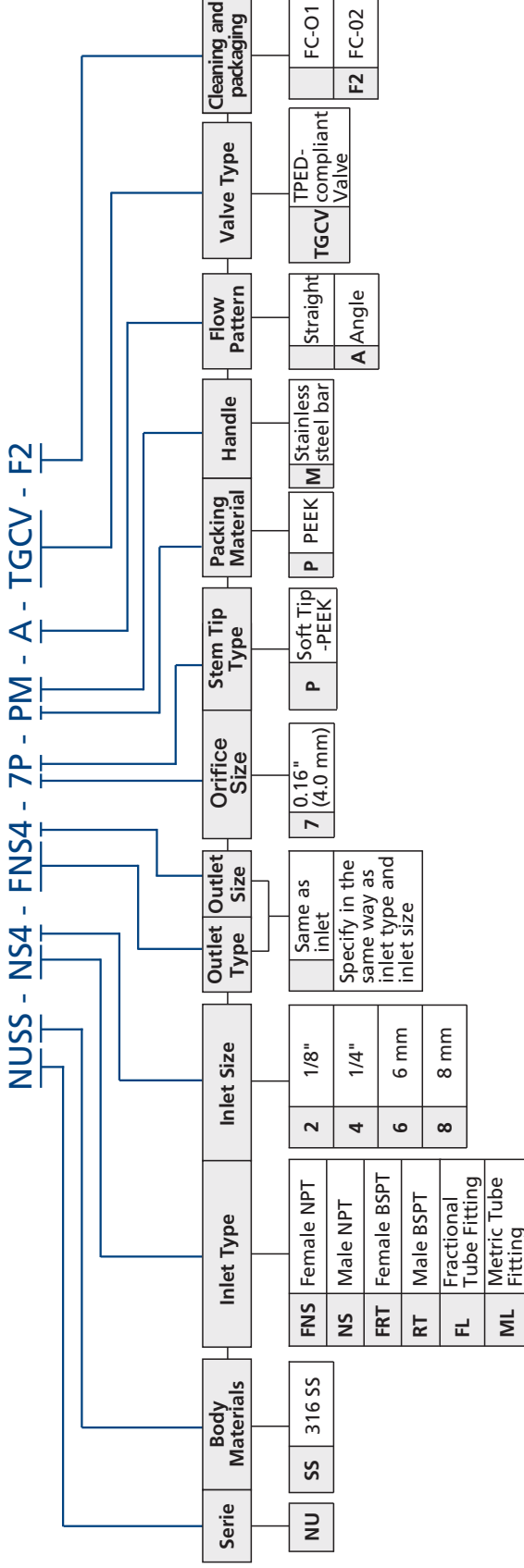

Note: "Ordering Number Description" is a reference to understand the combination rules of FITOK product part number. Not all combination is available. If any questions, please contact FITOK Group or our authorized distributors.

1. Cleaning and Packing:
 FC-01: Standard cleaning and packaging for general industrial procedures.
 FC-02: Special cleaning and packaging for wetted system components to ensure compliance with product cleanliness requirement of ASTM G93 Level C.

info@fitokgroup.com
www.fitokgroup.com

FK-IC-GV-15-EN-180329

Tools and Accessories



Contents

Hand Tube Benders

F-19

Tube Cutters

F-19

Tube Deburring Tools

F-20

Hydraulic Presetting Tools

F-20

Manual Presetting Tools

F-21

Gap Inspection Gauges

F-22

Bulkhead Retainers

F-23

Hand Tube Benders

Features

- ⦿ For bending stainless steel and copper tubing from 1/4" to 1/2" and 6 mm to 16 mm outside diameter
- ⦿ Roll dies reduce bending force and tube ovality, as compared to conventional slide block design
- ⦿ 1° to 180° bending range

Ordering Information

Ordering Number	Tube O.D.	Bend Radius
HTB-4S	1/4"	0.56"
HTB-4	1/4"	0.75"
HTB-5	5/16"	0.94"
HTB-6	3/8"	
HTB-8	1/2"	1.5"
HTB-6M	6 mm	15 mm
HTB-8M	8 mm	24 mm
HTB-10M	10 mm	
HTB-12M	12 mm	
HTB-14M-L	14 mm	56 mm
HTB-16M-L	16 mm	



The hand tube bender can not be used for SAF 2507 tubing over 1/4" or for medium-pressure tubing.

Tube Cutters

Features

- ⦿ For cutting stainless steel, soft copper, and aluminum tubing from 3/16" to 1" and 6 to 25 mm outside diameter
- ⦿ Flare-out and work hardening of tube end is reduced

Ordering Information

Ordering Number	Tube O.D.	Wheel Ordering Number
FTC-03	1/8" to 1" and 3 mm to 25 mm	FTC-03-RR
FTC-04	1/4" to 1 3/8" and 6 mm to 35 mm	FTCW-45
FTC-05	1/4" to 2 5/8" and 6 mm to 65 mm	

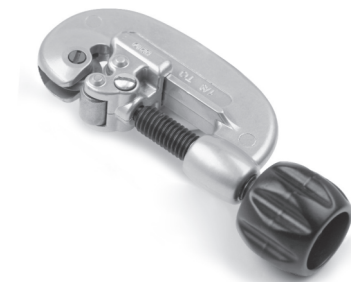

Tube Deburring Tools

Features

- For deburring stainless steel, carbon steel, copper and aluminum tube ends
- Steel blades for long life



Ordering Information

Ordering Number	Deburring Position	Size	Tube Material
TDT-01	I.D.	less than 6 mm	Stainless Steel, Carbon Steel, Copper, Aluminum
TDT-03	O.D.	6 mm to 38 mm and 1/4" to 1 1/2"	Copper, Aluminum
	I.D.		
TDT-05	O.D.	6 mm to 36 mm and 1/4" to 1 1/4"	Stainless Steel, Carbon Steel
	I.D.		

Hydraulic Presetting Tools

Features

- To preset ferrules onto tubing
- For installing 1/2" to 2" and 12 mm to 50 mm carbon steel, stainless steel, and alloy steel tube fittings
- Manually operated hydraulic pump, without requirement for power or compressed air
- Made of high grade alloy steel for more durable and firmer usage
- Flexible hose connection between the pump and jig to assure easy and comfortable operation
- Reduce assembly and installation time and operator error
- Fit neatly in a rugged plastic carrying case
- Figure dimensions (L x W x H): 12.6 in. x 9.8 in. x 5.9 in. (the height of handle excluded)



Ordering Information

HPT-03 Series

Ordering Number	Tube O.D.
HPT-03M	12 mm, 14 mm, 15 mm, 16 mm, 18 mm, 20 mm, 22 mm, 25 mm
HPT-03F	1/2", 5/8", 3/4", 7/8", 1"
HPT-03-U	Choose your needs from Die Heads for HPT-03 Series
HPT-03	Include HPT-03M and HPT-03F

Die Heads for HPT-03 Series

Ordering Number	Tube O.D.
HPT-ML12	12 mm
HPT-ML14	14 mm
HPT-ML15	15 mm
HPT-ML16	16 mm
HPT-ML18	18 mm
HPT-ML20	20 mm
HPT-ML22	22 mm
HPT-ML25	25 mm
HPT-FL8	1/2"
HPT-FL10	5/8"
HPT-FL12	3/4"
HPT-FL14	7/8"
HPT-FL16	1"

HPT-05 Series

Ordering Number	Tube O.D. (Dimensions)
HPT-05M	28 mm, 30 mm, 32 mm, 38 mm, 50 mm
HPT-05F	1-1/4", 1-1/2", 2"
HPT-05-U	Choose your needs from Die Heads for HPT-05 Series
HPT-05	Include HPT-05M and HPT-05F

Die Heads for HPT-05 Series

Ordering Number	Tube O.D.
HPT-ML28	28 mm
HPT-ML30	30 mm
HPT-ML32	32 mm
HPT-ML38	38 mm
HPT-ML50	50 mm
HPT-FL20	1-1/4"
HPT-FL24	1-1/2"
HPT-FL32	2"

Manual Presetting Tools

Features

For tube fitting installations in close quarters, the presetting tool can make installation easier and more reliable when paired with the table vice.

- ⦿ For installing 1/4" to 1" and 6 mm to 25 mm carbon steel, stainless steel and alloy steel tube fittings
- ⦿ High grade alloy used for clamp to make the presetting tool reliable and durable
- ⦿ Easy mounting to table vice
- ⦿ Wider and safer work condition



Ordering Information

Ordering Number	Tube O.D.
MPT-6M	6 mm
MPT-8M	8 mm
MPT-10M	10 mm
MPT-12M	12 mm
MPT-14M	14 mm
MPT-15M	15 mm
MPT-16M	16 mm
MPT-18M	18 mm
MPT-20M	20 mm
MPT-22M	22 mm
MPT-25M	25 mm

Ordering Number	Tube O.D.
MPT-4	1/4"
MPT-6	3/8"
MPT-8	1/2"
MPT-10	5/8"
MPT-12	3/4"
MPT-14	7/8"
MPT-16	1"

FITOK gap inspection gauge can not be used to check the fittings preset by MPT series presetting tools.

Gap Inspection Gauges

Features

On initial installation, the FITOK gap inspection gauge assures the installer or inspector that a fitting has been sufficiently tightened.

- ⦿ For all metal fittings, sizes from 1/16" to 1" and 2 mm to 25 mm
- ⦿ Simple and consistent operation

Ordering Information

Fitting Size		Ordering Number
in.	mm	
1/16	—	GIG-1
1/8	2, 3	GIG-2
3/16	4	GIG-3
1/4	6	GIG-4
5/16	8	GIG-5
3/8	—	GIG-6
—	10	GIG-10M
1/2	12	GIG-8
5/8	14, 15, 16	GIG-10
3/4	18	GIG-12
7/8	20, 22	GIG-14
1	25	GIG-16
1/4, 3/8, 1/2	6, 12	GIG-468
1/4, 1/2	6, 8, 10, 12	GIG-48



Bulkhead Retainers

Features

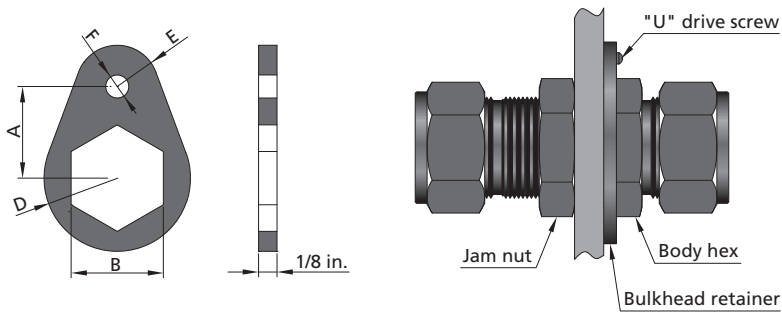

Bulkhead fitting installation utilizing bulkhead retainer

Ordering Information

Fitting Size		Ordering Number	Dimensions, in.						"U" Drive Screw Size	Drill Number
in.	mm		A	B	D	E	F	Drill Hole Dia		
1/16	—	SS-BR-1	3/8	5/16	5/16	5/32	5/32	0.120	6-3/8	31
1/8	—	SS-BR-2	1/2	1/2	13/32	7/32				
3/16	3,4	SS-BR-3	9/16	9/16	15/32	1/4				
1/4	6	SS-BR-4	5/8	5/8	1/2	9/32				
5/16	—	SS-BR-5	11/16	11/16	9/16	5/16				
—	8	SS-BR-M8	11/16	18mm	9/16	5/16				
3/8	—	SS-BR-6	3/4	3/4	5/8	11/32	7/32	0.161	10-1/2	20
—	10	SS-BR-M10	15/16	22mm	3/4	13/32				
1/2	12	SS-BR-8	15/16	15/16	3/4	13/32				
5/8	14,15,16	SS-BR-10	1	1-1/16	13/16	13/32				
3/4	18	SS-BR-12	1-1/16	1-3/16	29/32	15/32				
7/8	—	SS-BR-14	1-1/8	1-5/16	1-1/32	17/32				
1	25	SS-BR-16	1-9/32	1-5/8	1-5/32	9/16				

info@fitokgroup.com
www.fitokgroup.com

FK-IC-GO-01-EN-170608

Syphons

WS, LWS and UWS Series



Features

- Maximum working temperature: 850°F (454°C).
- Working pressure up to: 6000 psig (414 bar). Multiply the working pressure by the elevated temperature factors to get the working pressure at elevated temperature. To locate the elevated temperature factor, please refer to the related information on page F-14.
- Standard materials are 316 SS and 304 SS, other materials are available upon request.

Material Specifications

Component	Material Specifications
Tube	316L or 304L/A269
Connector	316 or 304/A276

Types and Dimensions

WS Series

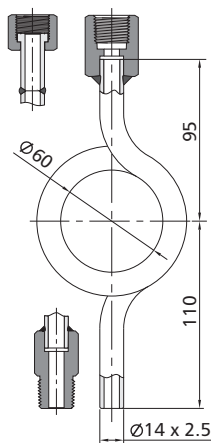

LWS Series

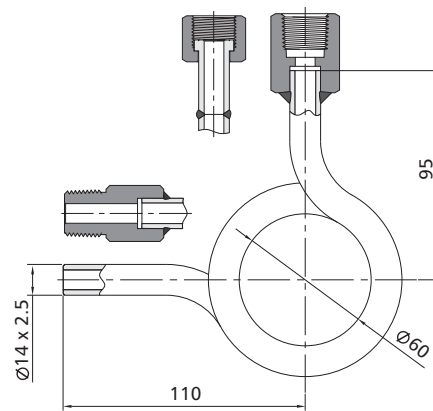

UWS Series

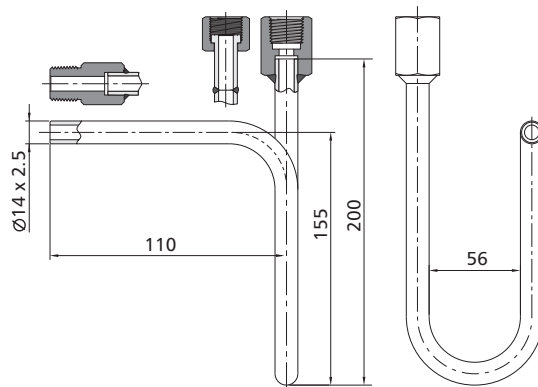

Dimensions are in mm unless otherwise specified. They are for reference only and are subject to change.

Ordering Information

Add the material designator as prefix to the basic ordering number (SS for 316 SS, S4 for 304 SS).

Example: **SS-WS-MTB14**

End Types and Size		Basic Ordering Number		
Cock End	Process End	WS Series	LWS Series	UWS Series
1/2 Female NPT	1/2 Female NPT	-WS-FNS8	-LWS-FNS8	-UWS-FNS8
1/2 Female NPT	1/4 Female NPT	-WS-FNS8-FNS4	-LWS-FNS8-FNS4	-UWS-FNS8-FNS4
1/2 Female NPT	1/2 Female ISO Parallel Thread	-WS-FNS8-RG8	-LWS-FNS8-RG8	-UWS-FNS8-RG8
1/2 Female NPT	1/4 Female ISO Parallel Thread	-WS-FNS8-RG4	-LWS-FNS8-RG4	-UWS-FNS8-RG4
1/2 Female NPT	M20 x 1.5 Female ISO	-WS-FNS8-MG20	-LWS-FNS8-MG20	-UWS-FNS8-MG20
1/2 Female NPT	M14 x 1.5 Female ISO	-WS-FNS8-MG14	-LWS-FNS8-MG14	-UWS-FNS8-MG14
1/2 Female NPT	1/2 Tube Socket Weld	-WS-FNS8-TS8	-LWS-FNS8-TS8	-UWS-FNS8-TS8
1/2 Female NPT	14 mm Tube Socket Weld	-WS-FNS8-MTS14	-LWS-FNS8-MTS14	-UWS-FNS8-MTS14
M20 x 1.5 Female ISO	M20 x 1.5 Female ISO	-WS-MG20	-LWS-MG20	-UWS-MG20
M20 x 1.5 Female ISO	M14 x 1.5 Female ISO	-WS-MG20-MG14	-LWS-MG20-MG14	-UWS-MG20-MG14
M20 x 1.5 Female ISO	∅ 14 x 2.5	-WS-MG20-MTB14	-LWS-MG20-MTB14	-UWS-MG20-MTB14
Rotating M20 x 1.5 Female ISO	M20 x 1.5 Female ISO	-WS-RMG20-MG20	-LWS-RMG20-MG20	-UWS-RMG20-MG20
Rotating M20 x 1.5 Female ISO	M14 x 1.5 Female ISO	-WS-RMG20-MG14	-LWS-RMG20-MG14	-UWS-RMG20-MG14
Rotating M20 x 1.5 Female ISO	∅ 14 x 2.5	-WS-RMG20-MTB14	-LWS-RMG20-MTB14	-UWS-RMG20-MTB14
1/2 Female ISO Parallel Thread	M20 x 1.5 Female ISO	-WS-RG8-MG20	-LWS-RG8-MG20	-UWS-RG8-MG20
1/2 Female ISO Parallel Thread	M14 x 1.5 Female ISO	-WS-RG8-MG14	-LWS-RG8-MG14	-UWS-RG8-MG14
1/2 Female ISO Parallel Thread	∅ 14 x 2.5	-WS-RG8-MTB14	-LWS-RG8-MTB14	-UWS-RG8-MTB14
Rotating 1/2 Female ISO Parallel Thread	M20 x 1.5 Female ISO	-WS-RRG8-MG20	-LWS-RRG8-MG20	-UWS-RRG8-MG20
Rotating 1/2 Female ISO Parallel Thread	M14 x 1.5 Female ISO	-WS-RRG8-MG14	-LWS-RRG8-MG14	-UWS-RRG8-MG14
Rotating 1/2 Female ISO Parallel Thread	∅ 14 x 2.5	-WS-RRG8-MTB14	-LWS-RRG8-MTB14	-UWS-RRG8-MTB14
∅ 14 x 2.5	∅ 14 x 2.5	-WS-MTB14	-LWS-MTB14	-UWS-MTB14
1/2 Male NPT	1/2 Male NPT	-WS-NS8	-LWS-NS8	-UWS-NS8
1/2 Male NPT	1/4 Female NPT	-WS-NS8-FNS4	-LWS-NS8-FNS4	-UWS-NS8-FNS4
1/2 Male ISO Parallel Thread	1/4 Male ISO Parallel Thread	-WS-BP8-BP4	-LWS-BP8-BP4	-UWS-BP8-BP4
1/2 Male ISO Parallel Thread	1/4 Female ISO Parallel Thread	-WS-BP8-RG4	-LWS-BP8-RG4	-UWS-BP8-RG4
M20 x 1.5 Male ISO	M20 x 1.5 Female ISO	-WS-MS20-MG20	-LWS-MS20-MG20	-UWS-MS20-MG20
M20 x 1.5 Male ISO	M14 x 1.5 Female ISO	-WS-MS20-MG14	-LWS-MS20-MG14	-UWS-MS20-MG14
M14 x 1.5 Male ISO	M20 x 1.5 Female ISO	-WS-MS14-MG20	-LWS-MS14-MG20	-UWS-MS14-MG20
M14 x 1.5 Male ISO	M14 x 1.5 Female ISO	-WS-MS14-MG14	-LWS-MS14-MG14	-UWS-MS14-MG14

FITOK Group

FITOK GmbH (Headquarter)

Sprendlinger Landstr. 115, 63069 Offenbach am Main, Germany
Tel.: +49 69 8900 4498 Fax: +49 69 8900 4495

FITOK, Inc.

13843 North Promenade Blvd., Suite 750, Stafford, Texas 77477, USA
Tel.: +1 281 888 0077 Fax: +1 281 582 4051

FITOK Incorporated

Block C, Zone E, Yingtai Industrial Park, Dalang Street,
Longhua District, Shenzhen, 518109, China
Tel.: +86 755 2803 2500 Fax: +86 755 2803 2619

FITOK Middle East Oil Equipment Trading LLC

208-209, Makateb Building, Airport Road, P.O.Box 185412, Deira, Dubai, UAE
Tel.: +971 4 2959 853 Fax: +971 4 2959 854

info@fitokgroup.com
www.fitokgroup.com

FK-IC-GO-02-EN-180509

Instrumentation Tubing

TMP and TCT Series

TMP Series

Features

- ⦿ Materials: stainless steel, duplex stainless steel or Nickel-based alloy
- ⦿ Sizes: 1/16" to 2" and 2 mm to 50 mm
- ⦿ Working temperature: -325°F to 1000°F (-198°C to 537°C)
- ⦿ Bright annealed or pickled with mechanically polished external surface
- ⦿ For use with FITOK 6 series tube fittings, 4:1 safety factor for the tubing and connection part of fitting and tubing
- ⦿ Marked with brand, material grade, standard, specification and heat number
- ⦿ Standard length: 1 m, 2 m, 3 m, 6 m, 10 ft, 20 ft
Customized length as per customer requirement is also available



Materials

UNS	Grade	ASTM Standard	FITOK Designator	Composition %					Mechanical Properties			
				C ≤	Cr	Ni	Mo	Others	Yield Strength MPa ≥	Tensile Strength MPa ≥	Elongation % ≥	Hardness ≤
S31600/ S31603	316/316L	A269	SS	0.035 ^①	16-18	10-14	2.0-3.0	-	205	515	35	80 HRB
Enhanced- S31600/ S31603	Enhanced- 316/316L		SH		17-18	12-14	2.6-3.0					
S30400/ S30403	304/304L		S4		18-20	8-11	-					
S31254	6Mo	A269	S12	0.02	19.5-20.5	17.5-18.5	6.0-6.5	-	310	675	35	96 HRB
S31803	2205	A789	D5	0.03	21-23	4.5-6.5	2.5-3.5	-	450	620	25	30 HRC
S32750	2507	A789	D7	0.03	24-26	6-8	3.0-5.0	Cu,N	550	800	15	32 HRC
N04400	Alloy 400	B165	M	0.30	-	≥63	-	Cu 28-34	195	480	35	75 HRB
N08020	Alloy 20	B729	A20	0.07	19-21	32-38	2.0-3.0	Cu,Nb,Ta	240	550	30	95 HRB
N06600	Alloy 600	B167	INC	0.15	14-17	≥72	-	Cu	205	550	35	92 HRB
N06625	Alloy 625	B444	A65	0.10	20-23	≥58	8.0-10.0	Cb,Ta	414	827	30	25 HRC
N08825	Alloy 825	B163	A85	0.05	19.5-23.5	38-46	2.5-3.5	Cu,Ti	241	586	30	201 HV
N10276	Alloy C-276	B622	HC	0.01	14.5-16.5	BAL	15.0-17.0	W	283	690	40	100 HRB

① The carbon content of tubing with outside diameter smaller than 1/2" or wall thickness smaller than 0.049" is allowed up to 0.04%.

Dimensional Tolerance

Materials	Tube O.D. (D) in. (mm)	O.D. Tolerance in. (mm)	Wall Thickness Tolerance %
316/316L Enhanced-316/316L 304/304L 6Mo	$D < 3/32$ (2.38)	+0.002 (0.05)/-0	+/-10
	$3/32$ (2.38) $\leq D < 3/16$ (4.76)	+0.003 (0.08)/-0	
	$3/16$ (4.76) $\leq D \leq 1$ (25.4)	+/-0.004 (0.10)	
	1 (25.4) $< D < 1\ 1/2$ (38.1)	+/-0.005 (0.13)	
	$1\ 1/2$ (38.1) $\leq D < 2$ (50.8)	+/-0.008 (0.2)	
	$D \geq 2$ (50.8)	+/-0.010 (0.25)	
2205 2507	$D < 1/2$ (12.7)	+/-0.005 (0.13)	+/-15
	$1/2$ (12.7) $\leq D \leq 3/4$ (19.05)		+/-10
Alloy 400 Alloy 20	$D < 5/8$ (16)	+/-0.005 (0.13)	+/-15
	$5/8$ (16) $\leq D < 1$ (25)		+/-10
Alloy 600	$D < 5/8$ (16)	+/-0.005 (0.13)	+/-12.5
Alloy 625	$3/16$ (4.8) $\leq D < 1/2$ (12.7)	+0.004 (0.10)/-0	+/-10
	$D \geq 1/2$ (12.7)	+0.005 (0.13)/-0	
Alloy 825	$D \leq 1/2$ (12.7)	+/-0.005 (0.13)/-0	+/-12.5
Alloy C-276		+/-0.005 (0.13)	

Working Pressure at Ambient Temperature

Working pressures in the table below apply only to 316/316L, enhanced-316/316L and 304/304L. For working pressures of other materials, please contact FITOK Group or our authorized distributors.

Fractional

Tube O.D. in.	Wall Thickness in.															
	0.010	0.012	0.014	0.016	0.020	0.028	0.035	0.049	0.065	0.083	0.095	0.109	0.120	0.134	0.156	0.188
	Working Pressure psig															
1/16	5600	6800	8100	9400	12000											
1/8						8500	10900									
3/16						5400	7000	10200								
1/4						4000	5100	7500	10200							
5/16							4000	5800	8000							
3/8							3300	4800	6500							
1/2							2600	3700	5100	6700						
5/8								2900	4000	5200	6000					
3/4								2400	3300	4200	4900	5800				
7/8								2000	2800	3600	4200	4800				
1									2400	3100	3600	4200	4700			
1 1/4										2400	2800	3300	3600	4100	4900	
1 1/2											2300	2700	3000	3400	4000	4900
2												2000	2200	2500	2900	3600

Note: For gas service, select a tube thickness outside of the shaded area when the tube is used with 6 series tube fittings.

Metric

Tube O.D. mm	Wall Thickness mm													
	0.8	1.0	1.2	1.5	1.8	2.0	2.2	2.5	2.8	3.0	3.5	4.0	4.5	5.0
	Working Pressure bar													
3	670													
6	310	420	540	710										
8		310	390	520										
10		240	300	400	510	580								
12		200	250	330	410	470								
14		160	200	270	340	380	430	490						
15		150	190	250	310	360	400	450						
16			170	230	290	330	370	400						
18			150	200	260	290	320	370						
20			140	180	230	260	290	330	380					
22			140	160	200	230	260	300	340					
25					180	200	230	260	290	320				
28						180	200	230	260	280	330			
30						170	180	210	240	260	310			
32						160	170	200	220	240	290	330		
38							140	160	190	200	240	270	310	
50										150	180	210	240	270

Note: For gas service, select a tube thickness outside of the shaded area when the tube is used with 6 series tube fittings.

Elevated Temperature Factors

Temperature		Factor	
°F	°C	316/316L and Enhanced-316/316L	304/304L
200	93	1.00	1.00
400	204	0.96	0.93
600	315	0.85	0.82
800	426	0.79	0.76
1000	537	0.76	0.69

TCT Series

Features

- ⦿ Materials: 316/316L, enhanced-316/316L or 304/304L
- ⦿ Sizes: 1/16" to 1/2" and 1.5 mm to 12 mm
- ⦿ Working temperature: -325°F to 1000°F (-198°C to 537°C)
- ⦿ Bright annealed with mechanically polished external surface
- ⦿ For use with FITOK 6 series tube fittings, 4:1 safety factor for the tubing and connection part of fitting and tubing
- ⦿ Marked with brand, material grade, standard, specification and heat number



Materials

UNS	Grade	ASTM Standard	FITOK Designator	Composition %				Mechanical Properties			
				C	Cr	Ni	Mo	Yield Strength MPa	Tensile Strength MPa	Elongation %	Hardness
S31600/S31603	316/316L	A269	SS	≤0.035 ^①	16-18	10-14	2.0-3.0	≥205	≥515	≥35	≤80 HRB
Enhanced-31600/31603	Enhanced-316/316L		SH		17-18	12-14	2.6-3.0				
S30400/S30403	304/304L		S4		18-20	8-11	-				

① The carbon content of tubing with outside diameter smaller than 1/2" or wall thickness smaller than 0.049" is allowed up to 0.04%.

Working Pressure

Refer to the working pressure of TMP series tubing.

Scope of Supply

Fractional

Tube O.D. in.	Wall Thickness in.	Standard Coil Length ^① ft	Max. Coil Length ^② ft
1/16	0.016	200	400
1/8	0.028	200	400
1/4	0.035	600	2130
	0.049	400	1550
	0.065		1280
3/8	0.035	400	1300
	0.049	300	970
	0.065		760
1/2	0.035 ^③	300	950
	0.049	220	700
	0.065		550
	0.083		450

① Minimum guaranteed length.

② Customized shorter length available subject to confirmation from FITOK.

③ Not recommended for use with 6 series tube fittings in gas service.

Metric

Tube O.D. mm	Wall Thickness mm	Standard Coil Length ^① m	Max. Coil Length ^② m
1.5	0.4	60	120
3	0.7	60	120
6	0.8	120	650
	1.0		600
	1.2		520
	1.5		450
8	1.0	120	380
	1.2		350
	1.5		310
10	1.0	100	320
	1.2		280
	1.5		240
12	1.0	80	240
	1.2		230
	1.5	60	190
	2.0		150

① Minimum guaranteed length.

② Customized shorter length available subject to confirmation from FITOK.

Ordering Number Description

SS - TMP - 6 - 049 - 20 - BA - F2

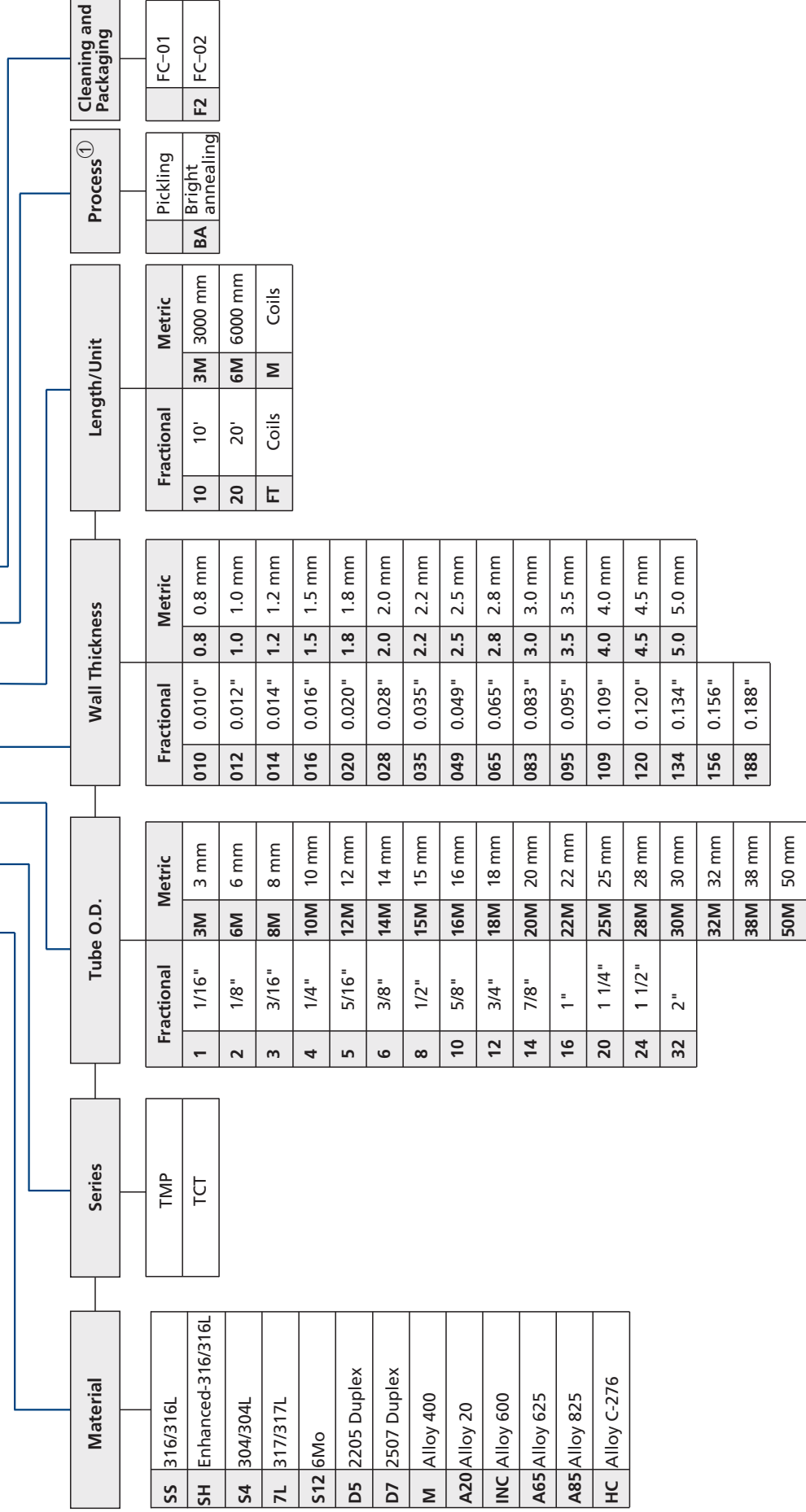

Note: "Ordering Number Description" is a reference to understand the combination rules of FITOK product part number. Not all combinations are available. For any questions, please contact FITOK group or our authorized distributors.

① Applicable to 316/316L and 304/304L TMP series tubing.

Jacketed Tubing and Insulated Tubing

TJT Series and TIT Series

Features

- ⦿ Materials:
 - TJT series: stainless steel or copper tubing, PVC jacket
 - TIT series: stainless steel or copper tubing, fibrous glass insulation, PVC jacket
- ⦿ Sizes: 1/4" to 1/2", 6 mm to 12 mm
- ⦿ Working temperature:
 - TJT series: -31°F to 194°F (-35°C to 90°C)
 - TIT series: -20°F to 400°F (-29°C to 204°C)
- ⦿ Stainless steel tubing bright annealed with mechanically polished external surface
- ⦿ For use with FITOK 6 series tube fittings, 4:1 safety factor for the tubing and connection part of fitting and tubing
- ⦿ Outer jacket marked with brand, tubing material grade, standard, specification, heat number, and jacket material



Materials

Tubing

UNS	Grade	ASTM Standard	FITOK Designator	Composition %					Mechanical Properties			
				C	Cr	Ni	Mo	Cu	Yield Strength MPa	Tensile Strength MPa	Elongation %	Hardness
S31600/ S31603	316/ 316L	A269	SS	≤0.035 ^①	16-18	10-14	2.0-3.0	-	≥205	≥515	≥35	≤80 HRB
C10200	-	B75	CU	-	-	-	-	99.95	≥62	≥205	-	-

① The carbon content of tubing with outside diameter smaller than 1/2" or wall thickness smaller than 0.049" is allowed up to 0.04%.

PVC Jacket

Min. Tensile Strength	1530 psig (105 bar)
Min. Elongation	300%
Shore Hardness	80 HA
Max. Working Temperature	194°F (90°C)
Min. Installation Temperature	-31°F (-35°C)
Min. Working Temperature	-31°F (-35°C)
Resistance to Chloride	Yes
Max. Water Absorption	0.06%

Technical Data

TJT Series

Fractional

Material Code	UNS	Tube O.D. in.	Wall Thickness in.	Max. Working Temperature °F (°C)	Min. Working Temperature °F (°C)	Working Pressure psig	Min. Bend Radius in.	Jacket O.D. mm	Coiled Tubing		Straight-length Tubing ft				
									Standard ^① Coil Length ft	Max. ^② Coil Length ft					
SS	S31600/ S31603	1/4	0.035	194 (90)	-31 (-35)	5100	8.00	0.32	400	2130	20				
		3/8	0.035			3300		0.45		1300					
		1/2	0.035 ^③			2600		0.57	300	950					
			0.049			3700				700					
CU	C10200	1/4	0.035			194 (90)		-31 (-35)	1600	8.00		0.32	600	2130	20
		3/8	0.035						1000			0.45		1240	
		1/2	0.035 ^③						800			0.57	600	1082	
			0.049						1100					984	

Metric

Material Code	UNS	Tube O.D. mm	Wall Thickness mm	Max. Working Temperature °C (°F)	Min. Working Temperature °C (°F)	Working Pressure bar	Min. Bend Radius cm	Jacket O.D. mm	Coiled Tubing		Straight-length Tubing m				
									Standard ^① Coil Length m	Max. ^② Coil Length m					
SS	S31600/ S31603	6	1.0	90 (194)	-35 (-31)	420	20.3	7.9	120	650	6				
		10	1.0			240		11.7		300					
		12	1.0			200		13.7	100	240					
CU	C10200	6	1.0			90 (194)		-35 (-31)	140	20.3		7.9	200	650	6
		10	1.0						80			11.7		380	
		12	1.0 ^③						60			13.7		300	

① Minimum guaranteed length.

② Customized shorter length available subject to confirmation from FITOK.

③ Not recommended for use with 6 series tube fittings in gas service.

TIT Series
Fractional

Material Code	UNS	Tube O.D. in.	Wall Thickness in.	Max. Working Temperature °F (°C)	Min. Working Temperature °F (°C)	Working Pressure psig	Min. Bend Radius in.	Nominal Product O.D. in.	Standard ^① Coil Length ft	Max. ^② Coil Length ft
SS	S31600/ S31603	1/4	0.035	400 (204)	-20 (-29)	4900	8.00	1.00	400	1100
		3/8	0.035			3200		1.13		1050
		1/2	0.035 ^③			2500		1.25	300	1000
			0.049			3500				900
CU	C10200	1/4	0.035			800		1.00	600	1000
		3/8	0.035			500		1.13		980
		1/2	0.035 ^③			400		1.25	600	
			0.049			550				

Metric

Material Code	UNS	Tube O.D. mm	Wall Thickness mm	Max. Working Temperature °C (°F)	Min. Working Temperature °C (°F)	Working Pressure bar	Min. Bend Radius cm	Nominal Product O.D. mm	Standard ^① Coil Length m	Max. ^② Coil Length m
SS	S31600/ S31603	6	1.0	204 (400)	-29 (-20)	403	20.3	24.9	120	330
		10	1.0			230		28.7		300
		12	1.0			192		30.7	100	240
CU	C10200	6	1.0			70		24.9	200	330
		10	1.0			40		28.7		300
		12	1.0 ^③			30		30.7		300

- ① Minimum guaranteed length.
- ② Customized shorter length available subject to confirmation from FITOK.
- ③ Not recommended for use with 6 series tube fittings in gas service.

Ordering Number Description

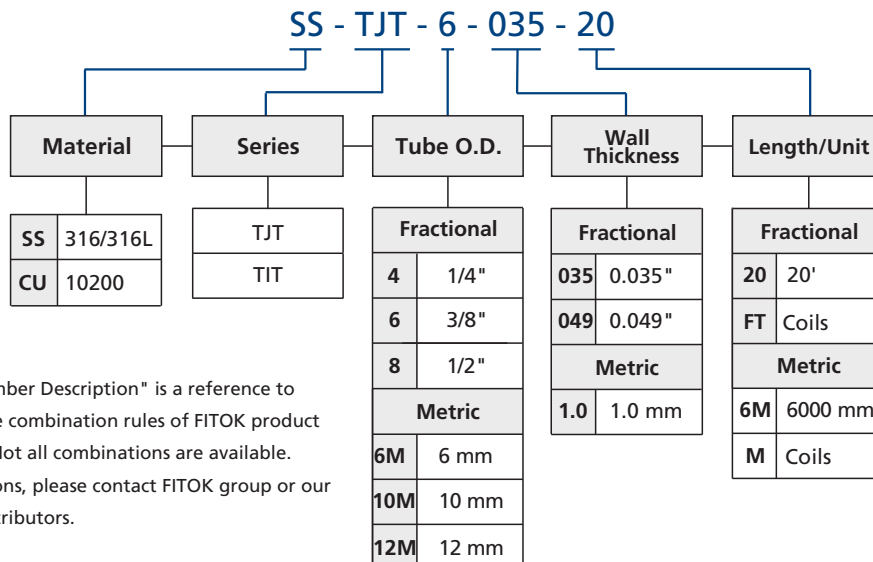

Note: "Ordering Number Description" is a reference to understand the combination rules of FITOK product part number. Not all combinations are available. For any questions, please contact FITOK group or our authorized distributors.

Heat Trace Tubing

TST Series

Features

- ⦿ Steam trace
- ⦿ Materials: stainless steel or copper process tube and tracer tube, fibrous glass insulation, PVC jacket
- ⦿ Sizes:
Process tube: 3/8", 1/2" and 10 mm
Tracer tube: 1/2", 6 mm and 8 mm
- ⦿ Maintains process temperatures from 50°F to 355°F (10°C to 179°C)
- ⦿ For use with FITOK 6 series tube fittings, 4:1 safety factor for tubing and connection part of fitting and tubing
- ⦿ Jacket marked with brand, heat trace type, ordering number and heat number



Materials of Process Tube and Tracer Tube

UNS	Grade	ASTM Standard	FITOK Designator	Composition %					Mechanical Properties			
				C	Cr	Ni	Mo	Cu	Yield Strength MPa	Tensile Strength MPa	Elongation %	Hardness
S31600/ S31603	316/ 316L	A269	SS	≤0.035 ^①	16-18	10-14	2.0-3.0	-	≥205	≥515	≥35	≤80HRB
C10200	-	B75	CU	-	-	-	-	99.95	≥62	≥205	-	-

① The carbon content of tubing with outside diameter smaller than 1/2" or wall thickness smaller than 0.049" is allowed up to 0.04%.

PVC Jacket

Min. Tensile Strength	1530 psig (105 bar)
Min. Elongation	300%
Shore Hardness	80 HA
Max. Working Temperature	194°F (90°C)
Min. Installation Temperature	-31°F (-35°C)
Min. Working Temperature	-31°F (-35°C)
Resistance to Chloride	Yes
Max. Water Absorption	0.06%

Types

Light Heat Trace

Heavy Heat Trace

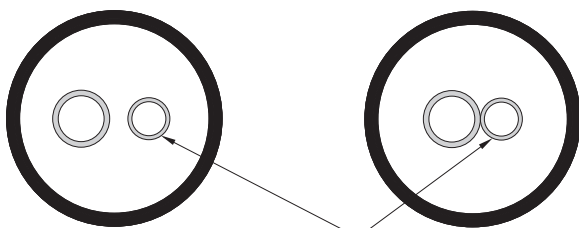

Heat Trace Tubing

Temperature Maintenance Range

Light Heat Trace	Heavy Heat Trace
50°F to 200°F (10°C to 93°C)	200°F to 355°F (93°C to 179°C)

Technical Data

Fractional

Process Tube Tube O.D. x Wall Thickness, in.	Tracer Tube Tube O.D. x Wall Thickness, in.	Nominal Product O.D. in.	Min. Bend Radius in.	Standard Coil Length ^① ft	Max. Coil Length ^② ft
316/316L Process Tube and Tracer Tube					
3/8 × 0.035	3/8 × 0.035	1 1/2	8.00	400	1050
1/2 × 0.035 ^③	3/8 × 0.035			300	1000
1/2 × 0.049	1/2 × 0.049				900
C10200 Process Tube and 316/316L Tracer Tube					
3/8 × 0.035	3/8 × 0.035	1 1/2	8.00	600	980
1/2 × 0.035 ^③	3/8 × 0.035				
1/2 × 0.049	1/2 × 0.049				

① Minimum guaranteed length.

② Customized shorter length available subject to confirmation from FITOK.

③ Not recommended for use with 6 series tube fittings in gas service.

Metric

Process Tube Tube O.D. x Wall Thickness, mm	Tracer Tube Tube O.D. x Wall Thickness, mm	Nominal Product O.D. mm	Min. Bend Radius cm	Standard Coil Length ^① m	Max. Coil Length ^② m
316/316L Process Tube and Tracer Tube					
10 × 1	6 × 1	38	20.3	100	300
10 × 1	8 × 1				
C10200 Process Tube and 316/316L Tracer Tube					
10 × 1	6 × 1	38	20.3	120	300
10 × 1	8 × 1				

① Minimum guaranteed length.

② Customized shorter length available subject to confirmation from FITOK.

Working Pressure

Refer to the working pressure of TMP series tubing.

Ordering Information

Fractional

Please add the length unit "M" or "FT" after the basic ordering number to get a complete ordering number.

316/316L Process Tube and Tracer Tube			
Process Tube	Tracer Tube	Basic Ordering Number	
Tube O.D. x Wall Thickness in.	Tube O.D. x Wall Thickness in.	Light Heat Trace	Heavy Heat Trace
3/8 × 0.035	3/8 × 0.035	SS-TST-L-6035-SS6035-□	SS-TST-H-6035-SS6035-□
1/2 × 0.035	3/8 × 0.035	SS-TST-L-8035-SS6035-□	SS-TST-H-8035-SS6035-□
1/2 × 0.049	1/2 × 0.049	SS-TST-L-8049-SS8049-□	SS-TST-H-8049-SS8049-□
C10200 Process Tube and 316/316L Tracer Tube			
3/8 × 0.035	3/8 × 0.035	CU-TST-L-6035-SS6035-□	CU-TST-H-6035-SS6035-□
1/2 × 0.035	3/8 × 0.035	CU-TST-L-8035-SS6035-□	CU-TST-H-8035-SS6035-□
1/2 × 0.049	1/2 × 0.049	CU-TST-L-8049-SS8049-□	CU-TST-H-8049-SS8049-□

Metric

316/316L Process Tube and Tracer Tube			
Process Tube	Tracer Tube	Ordering Number	
Tube O.D. x Wall Thickness mm	Tube O.D. x Wall Thickness mm	Light Heat Trace	Heavy Heat Trace
10 × 1	6 × 1	SS-TST-L-10M1.0-SS6M1.0-M	SS-TST-H-10M1.0-SS6M1.0-M
10 × 1	8 × 1	SS-TST-L-10M1.0-SS8M1.0-M	SS-TST-H-10M1.0-SS8M1.0-M
C10200 Process Tube and 316/316L Tracer Tube			
10 × 1	6 × 1	CU-TST-L-10M1.0-SS6M1.0-M	CU-TST-H-10M1.0-SS6M1.0-M
10 × 1	8 × 1	CU-TST-L-10M1.0-SS8M1.0-M	CU-TST-H-10M1.0-SS8M1.0-M