

Pressure Measurement Solutions



Dial Indicating
Digital
Differential
& Sanitary
Gauges



Diaphragm Seals
& Accessories



NOSHOK is built on a foundation of commitment to our customers and dedication to providing the highest level of service and quality in the industry. We take that responsibility very seriously, and those values are integrated into every product we sell and every facet of our business. If you choose to do business with us, you can expect to be our number one priority.

THE NOSHOK DIFFERENCE:

- Personal, immediate Customer Service
- Dedicated to every customer's satisfaction equally
- Independently owned and operated
- Top of the line product workmanship
- Creative, personalized solutions designed to fit your specific needs

This dedication to quality and customer satisfaction has endured for over 40 years, and has extended to all of our pressure, level, temperature and force measurement products, along with our needle and manifold valves.

This catalog presents our full line of Pressure Measurement Solutions. If you need personal assistance in solving your own unique pressure measurement challenge, please feel free to contact us at 440.243.0888.

Thank you for choosing NOSHOK!



James B. Cole
Chief Executive Officer



NOSHOK Corporate Headquarters

Your Single Source Instrumentation Company

NOSHOK is a member and actively supports:



NOSHOK is an ISO 9001:2008 registered company

T A B L E O F C O N T E N T S

WARRANTY INFORMATION

Dry Gauges	4
Liquid Filled Gauges	4-5
Diaphragm Seals and Accessories	5

DIAL INDICATING PRESSURE GAUGES

Standard (100 SERIES).....	6-9
Low Pressure Diaphragm (200 SERIES)	10-13
Brass Case Liquid Filled (300 SERIES).....	14-17
Stainless Steel (400/500 SERIES)	18-21
Process (600/700 SERIES)	22-23
Precision Test (800 SERIES)	24-25
ABS & Stainless Steel Liquid Filled (900 SERIES)	26-29

DIGITAL PRESSURE GAUGE

Digital Gauge (1000 SERIES)	30-31
-----------------------------------	-------

DIFFERENTIAL PRESSURE GAUGES

Piston Type (1000 SERIES)	32-33
Diaphragm Type (1100 SERIES)	34-35
Membrane Type High Static (1200 SERIES)	36-37
Membrane Type Nominal Static (1300 SERIES)	38-39
Dial Layouts (1000 & 1100 SERIES)	40-41

SANITARY PRESSURE GAUGES

Fractional (10 SERIES)	42-43
Heavy-Duty (10 SERIES)	44-45
Homogenizer (20 SERIES)	46-47

DIAPHRAGM SEALS

Clamped Style Replaceable

Standard Pressure Clamped Style Replaceable Diaphragm Seal (TYPE 10)	48-49
Elevated Pressure Clamped Style Replaceable Diaphragm Seal (TYPE 10H)	48-49
Reduced Pressure Clamped Style High Volumetric Displacement Diaphragm Seal (TYPE 10L)	50-51

Miniature Welded

Standard Pressure Miniature Welded Diaphragm Seal (TYPE 25)	56-57
Elevated Pressure Miniature Welded Diaphragm Seal (TYPE 25H)	56-57
High Volumetric Displacement Miniature Welded Diaphragm Seal (TYPE 29)	58-59

Clamped Style Welded

Tri-Clamp Sanitary Pressure Welded Diaphragm Seal (TYPE 12)	52-53
--	-------

Front Flush Button Style Welded Diaphragm Seal (TYPE 20)	54-55
Standard Pressure Clamped Style Welded Diaphragm Seal (TYPE 30)	60-61
Elevated Pressure Clamped Style Welded Diaphragm Seal (TYPE 30H).....	60-61
Reduced Pressure Clamped Style High Volumetric Displacement Welded Diaphragm Seal (TYPE 30L)...	62-63

OPTIONS & ACCESSORIES

Overview Chart by Series	64-67
--------------------------------	-------

GAUGE OPTIONS & ACCESSORIES DETAILED INFORMATION

Panel Mounting/Flanges	68
Cases & Cover Rings	68
Lenses	68
Maximum Indicating Pointers	68
Set Pointers	69
Rubber Case Protectors	69
Orifices	69
Recalibrators	69
Overpressure Protection	69
Ammonia Gauges	69
Liquid Filling Options.....	69
Special Connections	69
Reid Vapor Test Gauges	69
Receiver Gauges	70
Metric Dials & Customized Special Dials	70
Certified Calibration	70

PRESSURE SNUBBERS

Piston Type	71
Sintered	71

Pigtail Steam Syphons	72
-----------------------------	----

Swivel Adapter	73
----------------------	----

Magnetic Spring Contact Switch	73
--------------------------------------	----

Gauge Accuracy/Standard Dial Configuration Charts	74-78
--	-------

Reference Material	79-80
--------------------------	-------

Frequently Asked Questions	81-82
----------------------------------	-------

Warranty Information Dry Pressure Gauges

Three Year Warranty applies to:

- 1000 Series Digital Gauge

One Year Warranty applies to:

- 100, 200, 400, 640, 740, and 800 Series Dry Gauges
- 10 and 20 Series Dry Sanitary Gauges
- 1000, 1100, 1200, and 1300 Series Dry Differential Gauges

NOSHOK warrants these products:

- To be free from defects in material and workmanship
- To remain within catalogued accuracy specifications
- To operate within the catalogued performance specifications

Limitations which apply are:

- Bourdon tube pressure gauges must be used within their calibrated maximum range to prevent damage
- The pressure gauges must be operated within the following working pressure limits:
 - o Dynamic Pressure application, 60% of the dial range
 - o Static Pressure applications, where no sharp fluctuations occur, 90% of the dial range
- The gauges must be operated within specified ambient temperature ranges

Determination of gauge failures will be made by NOSHOK, Inc., which will use its equipment and personnel or a certified test facility specializing in this type of evaluation and determination. Gauge failures determined to be caused by over-range, incompatibility with environment or product media and abuse will not be considered under this warranty. NOSHOK, Inc. will, at its discretion, repair or replace the working parts of the damaged gauge without cost to the customer. This written warranty applies only to the NOSHOK gauges referenced in the first paragraph of this warranty, sold by NOSHOK, Inc. and its authorized distributors.

CAUTION:

Operating conditions including, but not limited to, system pressure, media compatibility and ambient conditions must be considered when selecting gauges and accessories, improper selections and use of gauges could possibly cause gauge failure and lead to possible property damage or personal injury. Refer to the American National Standard ANSI B40.1 for the correct selection and use of gauges. A copy of this standard may be obtained from the American Society of Mechanical Engineers, United Engineering Center, 345 East 47th Street, New York, NY 10017.

In keeping with and for purposes of product and/or manufacturing process improvements, NOSHOK, Inc. reserves the right to make design changes without prior notice.

Warranty Information Liquid Filled Pressure Gauges

Three Year Warranty applies to:

- 300, 500, 660, 760, and 900 Series Liquid Filled Gauges
- 10 and 20 Series Liquid Filled Sanitary Gauges
- 1000, 1100, 1200, and 1300 Series Liquid Filled Differential Gauges

NOSHOK warrants these products:

- To be free from defects in material and workmanship
- To remain within catalogued accuracy specifications
- To maintain the integrity of the hermetically sealed case, therefore preventing leakage
- To operate within the catalogued performance specifications

Limitations which apply are:

- Bourdon tube pressure gauges must be used within their calibrated maximum range to prevent damage
- The pressure gauges must be operated within the following working pressure limits:
 - o Dynamic Pressure application, 60% of the dial range
 - o Static Pressure applications, where no sharp fluctuations occur, 90% of the dial range
- The gauges must be operated within specified ambient temperature ranges

Determination of gauge failures will be made by NOSHOK, Inc., which will use its equipment and personnel or a certified test facility specializing in this type of evaluation and determination. Gauge failures determined to be caused by over-range, incompatibility with environment or product media and abuse will not be considered under this warranty. NOSHOK, Inc. will, at its discretion, repair or

replace the working parts of the damaged gauge without cost to the customer. This written warranty applies only to the NOSHOK gauges referenced in the first paragraph of this warranty, sold by NOSHOK, Inc. and its authorized distributors.

CAUTION:

Operating conditions including, but not limited to, system pressure, media compatibility and ambient conditions must be considered when selecting gauges and accessories, improper selections and use of gauges could possibly cause gauge failure and lead to possible property damage or personal injury. Refer to the American National Standard ANSI B40.1 for the correct selection and use of gauges. A copy of this standard may be obtained from the American Society of Mechanical Engineers, United Engineering Center, 345 East 47th Street, New York, NY 10017.

WARNING:

Glycerine or silicone could result in a spontaneous chemical reaction or explosion when combined with strong oxidizing agents including, but not limited to, chlorine, oxygen, hydrochloric or nitric acid, and hydrogen peroxide. Do not use glycerine or silicone filled gauges or accessories in these types of service. Consult factory for application assistance.

In keeping with and for purposes of product and/or manufacturing process improvements, NOSHOK, Inc. reserves the right to make design changes without prior notice.

Warranty Information Diaphragm Seals & Accessories

One Year Warranty applies to:

- Diaphragm Seals
- Pressure Gauge Options & Accessories
 - o Panel Mounting/Flanges
 - o Cases & Cover Rings
 - o Lenses
 - o Maximum Indicating Pointers (MIP)
 - o Set Pointers (SP)
 - o Rubber Case Protectors (RCP)
 - o Orifices
 - o Recalibrators
 - o Overpressure Protection
 - o Ammonia Refrigeration Gauges
 - o Liquid Filling Options
 - o Special Connections
 - o Reid Vapor Test Gauges
 - o Receiver Gauges
 - o Metric Dials & Customized Special Dials
 - o Certified Calibration
 - o Carrying Case for 800 Series
- Pressure Snubbers
 - o Piston Type
 - o Sintered
- Steam Syphons
- Swivel Adapters
- Magnetic Spring Contact Switch (MSCS)

NOSHOK warrants these products:

- To be free from defects in material and workmanship
- To remain within catalogued accuracy specifications
- To operate within the catalogued performance specifications

Limitations which apply are:

These units must be operated within the catalogued environmental and application parameters. Determination of failure will be made by NOSHOK, Inc.'s equipment and personnel or a certified test facility specializing in this type of evaluation.

Dial Indicating Pressure Gauges

Standard



100 SERIES

- High quality dry gauges for reliable service on applications not corrosive to brass
- Vacuum and compound through 15,000 psi
- 1-1/2, 2, 2-1/2, 4 inch sizes – bottom, back, left and right side connections
- Dry, ABS case (steel, chrome or stainless steel optional)
- All brass or brass with Delrin® internals
- Panel Mount Clamp and Front Flange mounting
- Standard UV resistant dials are dual scale in psi and kPa (kilopascals); dual scale psi/bar and psi/kg/cm² are available in most popular ranges
- Stock availability

OPERATING SPECIFICATIONS

1. Working Pressure Limitations

a. Dynamic Pressure

The working pressure should be limited to 60% of the dial range.

b. Static Pressure

The working pressure, where no sharp fluctuations occur, should be limited to 90% of the dial range

2. Ambient Temperature

0°F to 140°F (-18°C to 60°C)

3. Media Temperature

-4°F to 140°F (-20°C to 60°C)

APPLICATIONS

- Hydraulics
- Pneumatics
- Petrochemical
- Medical
- Food
- Pharmaceutical
- Most industrial and commercial applications

ACCURACY

- 1-1/2, 2 and 2-1/2 Inch 100 Series Gauges: ±2.5%
- 4 Inch 100 Series Gauges: ±1.5%
- 4 Inch 105 Series Gauges: ±1.0%

For details on accuracy/standard dial configuration and dial layouts, see pages 74-78

	MODELS	SPECIFICATIONS
Case	15-100, 15-110, 20-100, 20-110, 20-148, 25-100, 40-100	ABS (Acryl Nitril Butadien Styrol)
	15-120, 20-120, 25-120	Black painted steel with chrome triangular bezel and U-Clamp
	40-105, 40-115	304 Stainless steel
Bezel	15-110, 20-110, 25-110	Built-in bezel, molded as an integral part of the case for ease of panel mounting.
	15-120, 20-120, 25-120	Chrome plated steel triangular bezel
Bayonet Ring	40-105, 40-115	304 Stainless steel
Lens	15-100, 15-110, 15-120, 20-100, 20-110, 20-120, 20-148, 25-100, 25-110, 25-120, 40-100	Clear front Plexiglass™
	40-105, 40-115	Plexiglass™
Bourdon Tube	15-100, 15-110, 15-120, 20-100, 20-120, 20-110, 20-148, 25-100, 25-120, 25-110, 40-100	Phosphor bronze
	40-105 and 40-115 (up to 600 psi)	Phosphor bronze "C" tube
	40-105 and 40-115 (greater than 600 psi)	316 Stainless steel coiled safety tube
Connection	15-100, 15-110, 15-120, 20-100, 20-110	1/8" NPT brass
	20-148	1/8" NPT/10-32 female brass
	20-100, 20-110, 20-120, 25-100, 25-110, 25-120, 40-100, 40-105, 40-115	1/4" NPT brass
	40-105, 40-115	1/2" NPT (available as a special order option)
Movement	15-100, 15-110, 15-120, 20-100, 20-110, 20-120, 20-148, 25-100, 25-110, 25-120, 40-100	Brass & Nylon, or All-Brass with highly polished bearing surfaces
	40-105, 40-115	Brass and Nickel-Silver with highly polished bearing surfaces
Accuracy	15-100, 15-110, 15-120, 20-100, 20-110, 20-120, 20-148, 25-100, 25-110, 25-120,	± 2.5% Full Scale ASME grade B
	40-100	± 1.5% Full Scale ASME grade A
	40-105, 40-115	± 1% Full Scale ASME grade 1A
Pointer	15-100, 15-110, 15-120, 20-100, 20-120, 20-110, 20-148, 25-100, 25-110, 25-120, 40-100	Molded plastic
	40-105, 40-115	Balanced micro-adjustable aluminum, black finish
Dial	15-100, 15-110, 15-120, 20-100, 20-110, 20-120, 20-148, 25-100, 25-110, 25-120, 40-100	White background with black psi scale and red kPa scale. UV resistant
	40-105, 40-115	Aluminum, white background with black psi scale and red kPa scale is Standard. Single scale psi and dual scales of psi/bar or psi/Kg/cm ² are available as stock options. UV resistant

ORDERING INFORMATION																
SERIES	100															
SIZE	15	1-1/2 Inch	20	2 Inch	25	2-1/2 Inch	40	4 Inch								
CASE TYPE	100	ABS, Bottom Connection	105	Heavy Duty SS Case, Bottom Connection (4" only)	110	ABS, Back Connection	115	Heavy Duty SS Case, Back Connection (4" only)	120	Steel Case Panel Mount	148	Square ABS, Panel Mount (2" only)				
PRESSURE RANGES	30" Vac	-30 inHg vacuum to 0	30/300	-30 inHg to 0 to 300 psi	200	0 psi to 200 psi	2000	0 psi to 2000 psi	30/15	-30 inHg to 0 to 15 psi	15	0 psi to 15 psi	300	0 psi to 300 psi	3000	0 psi to 3000 psi
	30/30	-30 inHg to 0 to 30 psi	30	0 psi to 30 psi	400	0 psi to 400 psi	5000	0 psi to 5000 psi	30/60	-30 inHg to 0 to 60 psi	60	0 psi to 60 psi	600	0 psi to 600 psi	6000	0 psi to 6000 psi
	30/100	-30 inHg to 0 to 100 psi	100	0 psi to 100 psi	1000	0 psi to 1000 psi	10000	0 psi to 10000 psi	30/160	-30 inHg to 0 to 160 psi	160	0 psi to 160 psi	1500	0 psi to 1500 psi	15000	0 psi to 15000 psi
	30/200	-30 inHg to 0 to 200 psi	Other ranges available on request													
SCALE OPTION	psi	psi single scale	psi/kPa	psi/kPa dual scale	psi/kg/cm ²	psi/kg/cm ² dual scale	psi/bar	psi/bar dual scale								
CONNECTION SIZE	1/8	1/8" NPT	7/16	7/16-20 SAE #4	1/4	1/4" NPT										
OPTIONS	PMC	Panel mount clamp	SBBF	Black front flange – steel case	CCR	Chrome cover ring**	MIP	Maximum indicating pointer								
	SSB	Polished Stainless steel bezel	SCFF	Chrome front flange – steel case	PCCR	Polished Chrome cover ring**	SDM	Silicone dampened movement								
	BR	Bayonet ring – 40-115 only	BSC	Black steel case	CAR	Chrome adapter ring	LM	Laser marking								
	BLRF	Black rear flange	SSC	Stainless steel case	LL	Lexan Lens	ST	Stainless steel tagging								
	SSRF	Stainless steel rear flange	CRC	Chrome case	GL	Glass lens*	CPO	Brass Sintered orifice 20 micron								
	BLFF	Black front flange – ABS case	FAC	Flat sided ABS case	SGL	Safety glass lens*	BP1	Brass press fit orifice 0.1 mm								
	CFF	Chrome front flange – ABS case	BCR	Black cover ring**	HL	Homalite lens*	BP3	Brass press fit orifice 0.3 mm								
	SSFF	Polished 304SS front flange	SSCR	Stainless steel cover ring**	SP	Red set pointer**	BP8	Brass press fit orifice 0.8 mm								

Please consult your local NOSHOK Distributor or NOSHOK, Inc. for availability and delivery information.

NOTE: Refer to 100 Series Options & Accessories chart on page 64 for availability by model number.

* A steel, stainless or chrome case & cover ring must be additionally ordered when lenses other than Plexiglass™ are utilized on all 100 Series models.

** Only 110 Models require a steel, stainless or chrome case & cover ring to be additionally ordered when utilizing a set pointer or cover ring. Please consult factory when a set pointer is to be utilized on a 120 Model.

EXAMPLE

1. Select model number (size & case type)
2. Select pressure range & scale option
3. Select NPT connection size (if more than one is offered)
4. Select any required accessory or option

20-110 - 100 psi - 1/4" - BSC

OUTLINE DIMENSIONS

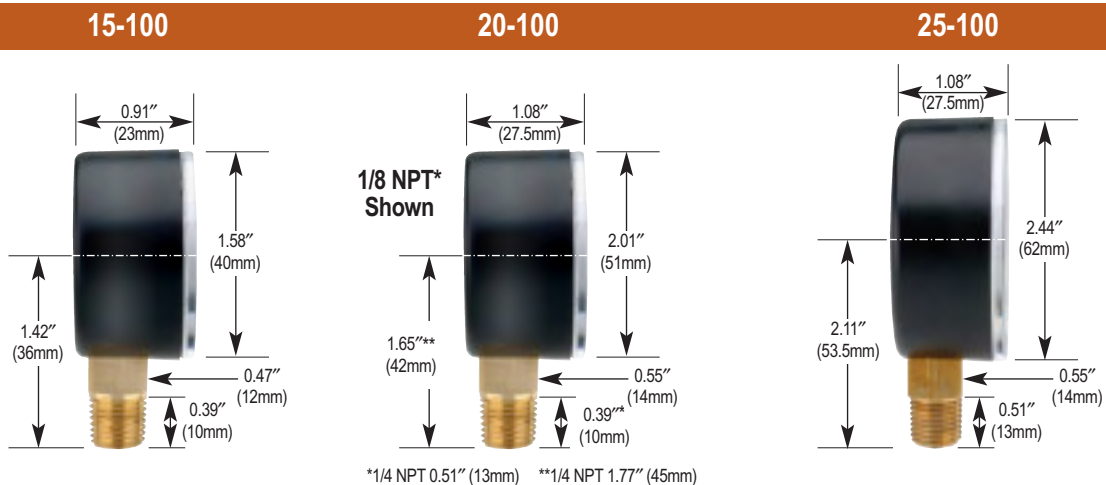

Dial Indicating Pressure Gauges

Dimensions

40-100

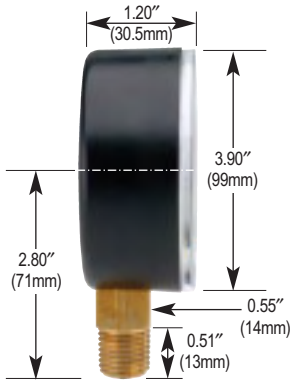

40-105

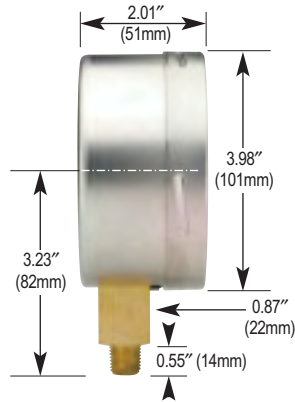

15-110

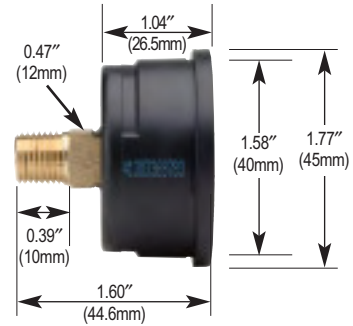

20-110

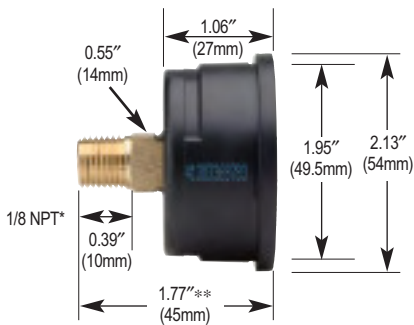

*1/4 NPT 0.51" (13mm) **1.89" (48mm)

20-148

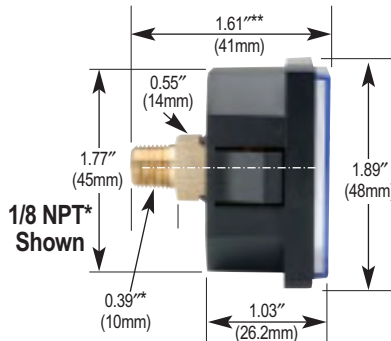

*1/4 NPT 0.51" (13mm) **1/4 NPT 1.81" (46mm)

25-110

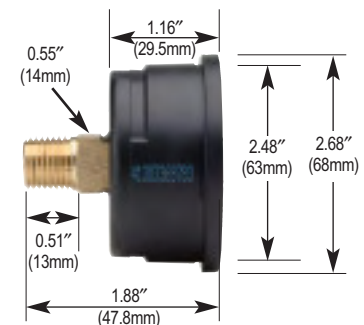

40-115

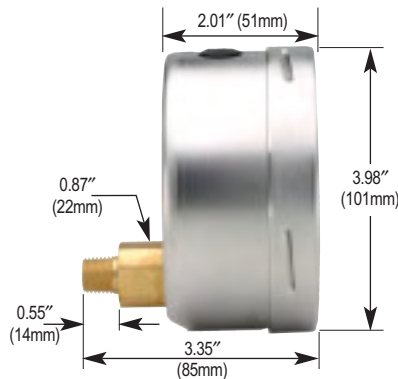

15-110 Front Flange

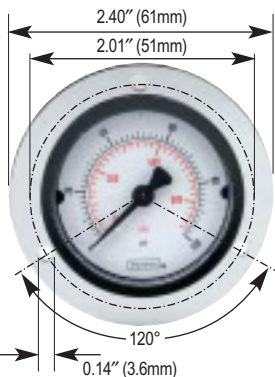

20-110 Front Flange

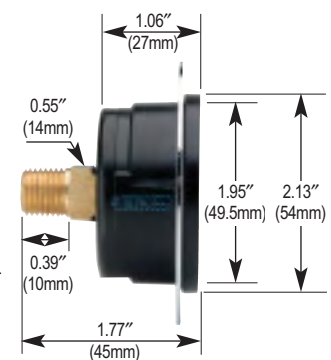
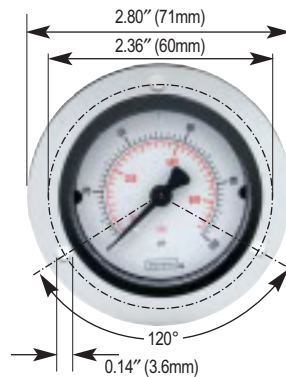
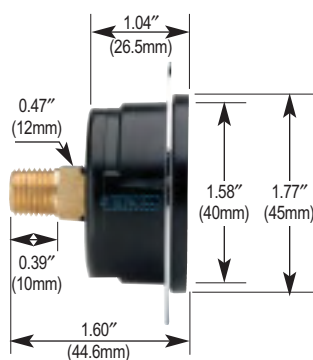

25-110 Front Flange

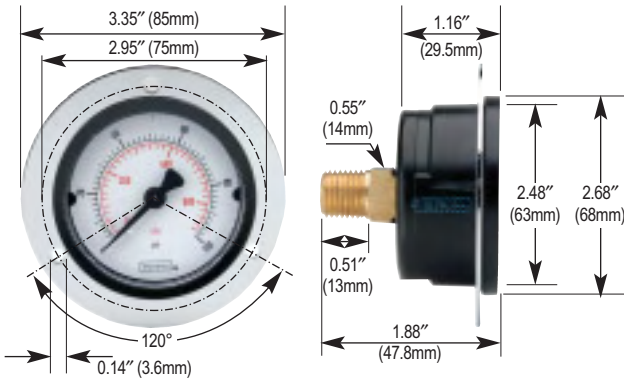

40-115 Front Flange

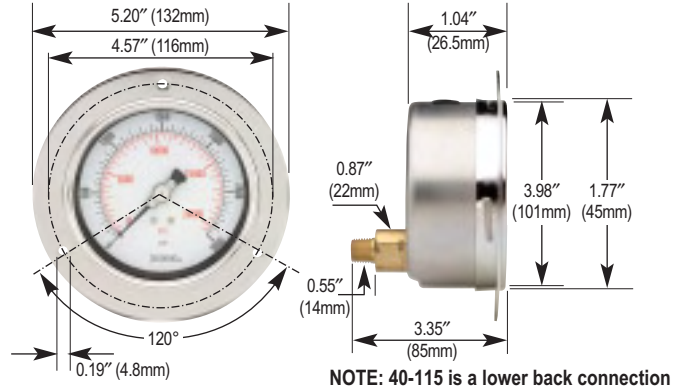

25-100 Rear Flange

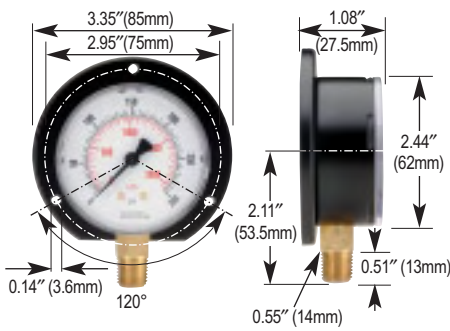

40-100 Rear Flange

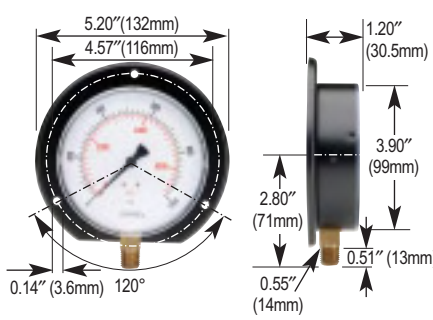

40-105 Rear Flange

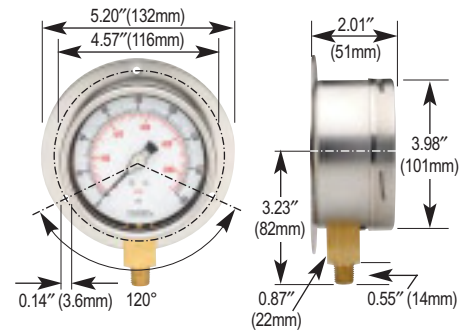

15-120 Chrome Triangular Bezel with U-Clamp

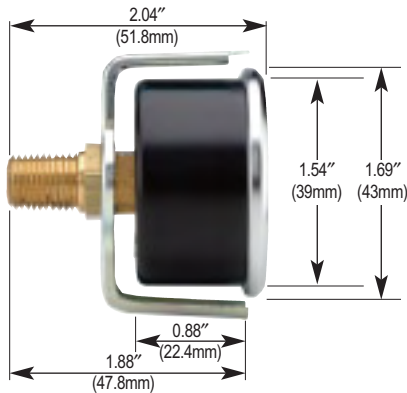

20-120 Chrome Triangular Bezel with U-Clamp

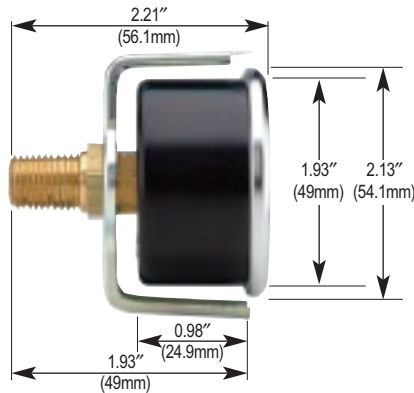

25-120 Chrome Triangular Bezel with U-Clamp

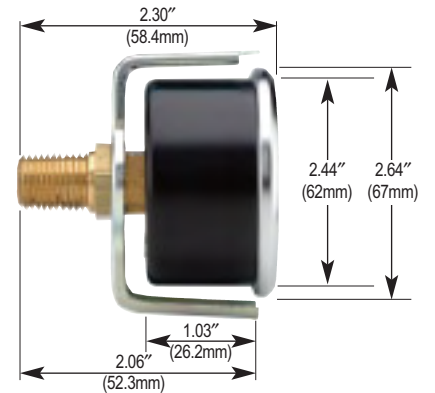

15-110 Panel Mount Clamp

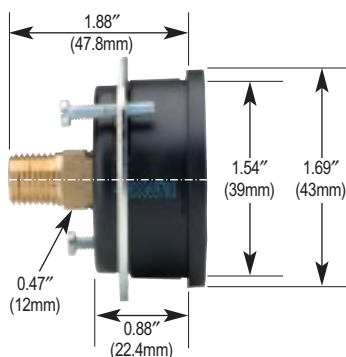

20-110 Panel Mount Clamp

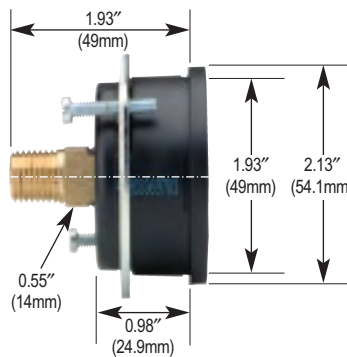

25-110 Panel Mount Clamp

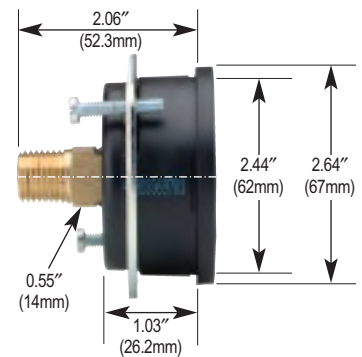

Low Pressure Diaphragm



200 SERIES

- Designed for extremely low pressure and vacuum measurement
- Ultra sensitive copper alloy diaphragm capsules are rated for pressure (or vacuum) as low as 0-10 inches of water and as high as 0-10 psi
- 2-1/2 and 4 inch sizes – bottom and back connections
- Molded Plexiglass™ lenses on 2-1/2 inch size and instrument glass on 4 inch size for strength and clarity
- Standard case on 2-1/2 inch size is black painted steel (optional stainless steel), and stainless steel on 4 inch case
- Phosphor bronze diaphragm capsules are coupled with precision all-brass movements to provide extremely accurate indication
- 25-206 & 25-216 are low pressure diaphragm OEM-Type gauges; they feature a black ABS case and a Copper Beryllium Alloy (CuBe) diaphragm capsule coupled with Cu-Alloy movement for extremely low pressure applications
- 25-200, 25-210 and 40-200 come standard with zero point adjustment
- Available options include overpressure protection of up to 200% of the dial range
- Stock availability

OPERATING SPECIFICATIONS

1. Working Pressure Limitations

- Dynamic Pressure**
The working pressure should be limited to 90% of the dial range.
- Static Pressure**
The working pressure, where no sharp fluctuations occur, should be limited to 100% of the dial range

2. Ambient Temperature

-4°F to 140°F (-20°C to 60°C)

3. Media Temperature

-4°F to 176°F (-20°C to 80°C)

APPLICATIONS

- Medical
- Biomedical
- HVAC
- Gas distribution
- Filtration
- Burner and gas combustion service
- Waste water treatment
- Level indication and filter monitoring
- Everywhere low pressure and vacuum measurement is required

ACCURACY

- 2-1/2 Inch 200 Series Gauges: ±1.5%
- 4 Inch 200 Series Gauges: ±1.0%

	MODELS	SPECIFICATIONS
Case	25-200, 25-210	Black painted steel
	25-206, 25-216, 25-224 zinc plated steel panel mount clamp	Black ABS (Acryl Nitril Butadien Styrol) with 25-224 includes
	40-200	304 Stainless steel
Bezel	40-200	304 Stainless steel
Lens	25-200, 25-206, 25-210, 25-216, 25-224	Clear front Plexiglass™
	40-200	Instrument glass
Diaphragm Capsule	25-200, 25-210, 25-224, 40-200	Phosphor bronze
Connection	25-200, 25-206, 25-210, 25-216, 25-224, 40-200	1/4" NPT brass
Movement	25-200, 25-210, 25-224, 40-200	Brass and Nickel-Silver with highly polished bearing surfaces
	25-206, 25-216	Cu-Alloy
Accuracy	25-200, 25-210, 25-224	± 1.5% Full Scale ASME grade A
	25-206, 25-216	± 2.5% Full Scale ASME grade B
	40-200	± 1% Full Scale ASME grade 1A
Pointer	25-200, 25-206, 25-210, 25-216, 25-224, 40-200	Black finished aluminum
Dial	25-200, 25-206, 25-210, 25-216, 25-224, 40-200	Aluminum, white background with black markings. Single scale except as noted in the dial configuration chart. UV resistant

For details on accuracy/standard dial configuration and dial layouts, see pages 74-78

ORDERING INFORMATION									
SERIES	200								
SIZE	25	2-1/2 Inch			40	4 Inch			
CASE TYPE	200	Steel, Bottom Connection (304SS for 4")			216	ABS, Back Connection			
	206	ABS, Bottom Connection			224	ABS, Panel Mount			
	210	Steel, Back Connection			234	Gas Pressure Test Kit**			
PRESSURE RANGES	15 inH ₂ O Vac	-15 inH ₂ O to 0 inH ₂ O	30 inH ₂ O	0 inH ₂ O to 30 inH ₂ O	15 oz/in ²	0 oz/in ² to 15 oz/in ²	20 oz/35 inH ₂ O	0 oz/in ² /inH ₂ O to 20 oz/in ² /inH ₂ O	
	30 inH ₂ O Vac	-30 inH ₂ O to 0 inH ₂ O	60 inH ₂ O	0 inH ₂ O to 60 inH ₂ O	30 oz/in ²	0 oz/in ² to 30 oz/in ²	32 oz/55 inH ₂ O	0 oz/in ² /inH ₂ O to 32 oz/in ² /inH ₂ O	
	60 inH ₂ O Vac	-60 inH ₂ O to 0 inH ₂ O	100 inH ₂ O	0 inH ₂ O to 100 inH ₂ O	35 oz/in ²	0 oz/in ² to 35 oz/in ²	3 psi	0 psi to 3 psi	
	100 inH ₂ O Vac	-100 inH ₂ O to 0 inH ₂ O	160 inH ₂ O	0 inH ₂ O to 160 inH ₂ O	60 oz/in ²	0 oz/in ² to 60 oz/in ²	5 psi	0 psi to 5 psi	
	10 inH ₂ O	0 inH ₂ O to 10 inH ₂ O	200 inH ₂ O	0 inH ₂ O to 200 inH ₂ O	100 oz/in ²	0 oz/in ² to 100 oz/in ²	10 psi	0 psi to 10 psi	
	15 inH ₂ O	0 inH ₂ O to 15 inH ₂ O	10 oz/in ²	0 oz/in ² to 10 oz/in ²	160 oz/in ²	0 oz/in ² to 160 oz/in ²			
CONNECTION SIZE	1/4	1/4" NPT							
OPTIONS	BLRF	Black rear flange	GL	Glass lens*	OP	Over pressure protection	CCR	Chrome cover ring	
	SSRF	304SS rear flange	SGL	Safety glass lens*	SSB-U	Stainless steel bezel & U-clamp	LM	Laser marking	
	BLFF	Black front flange	PL	Plexiglass™ lens	BB-U	Black bezel & U-clamp	ST	Stainless steel tagging	
	SSFF	304SS front flange	RL	Recalibrator lens	BCR	Black cover ring	BP3	Brass press fit orifice 0.3 mm	
	CFE	Chrome front flange	SP	Red set pointer	SSCR	Stainless steel cover ring	BT3	Brass threaded orifice 0.3 mm	
	SSC	Stainless steel case	MIP	Maximum indicating pointer					

Please consult your local NOSHOK Distributor or NOSHOK, Inc. for availability and delivery information.

NOTE: Refer to 200 Series Options & Accessories chart on page 65 for availability by model number.

* A steel, stainless or chrome cover ring must be additionally ordered when lenses other than Plexiglass™ are utilized on all 200 Series models

** Only available in 2-1/2 inch size, 20 oz/35 inH₂O

EXAMPLE

25-200 - 30 inH₂O - 1/4" - BP3

1. Select model number (size & case type)
2. Select pressure range
3. Connection size
4. Select any required accessory or option

OUTLINE DIMENSIONS

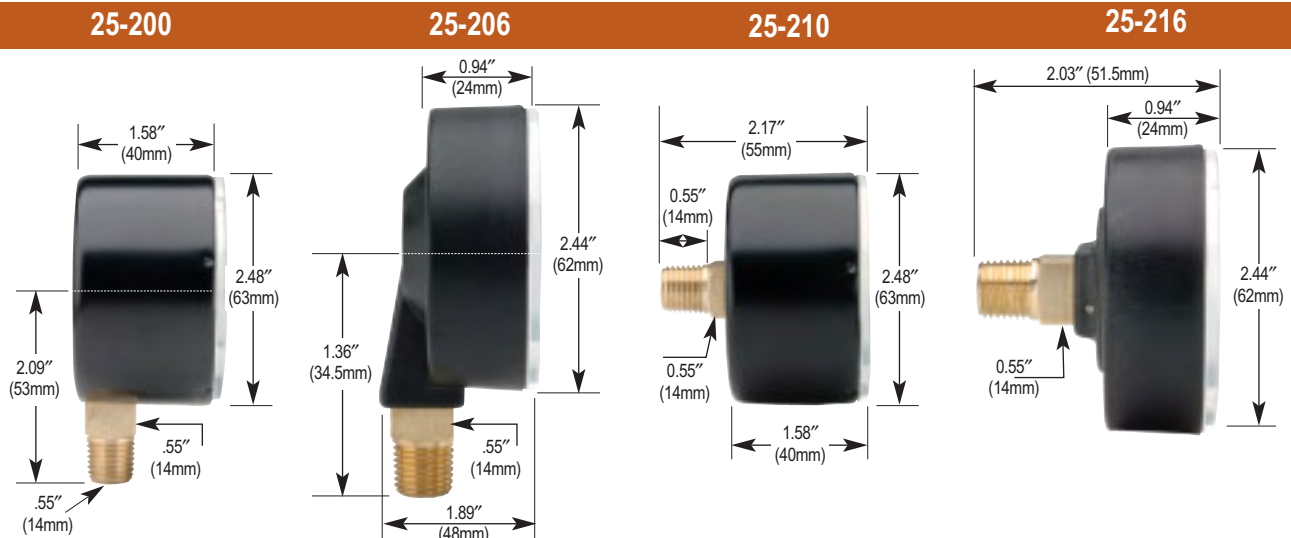

Dial Indicating Pressure Gauges

Dimensions

25-210 Front Flange

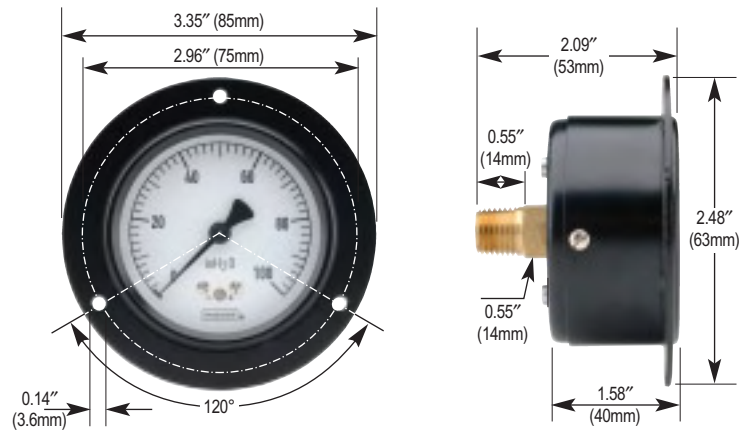

25-200 Rear Flange

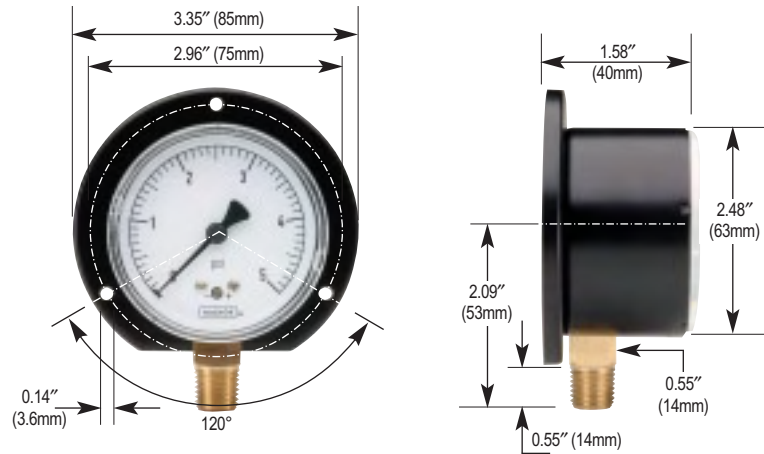

40-200 Rear Flange

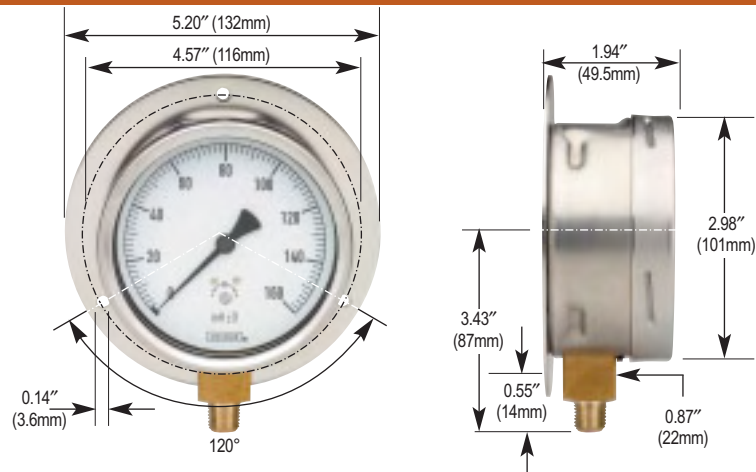

25-210 Triangular Bezel with U-Clamp

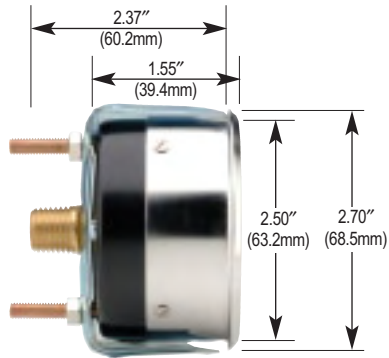

25-224 With Panel Mount Clamp

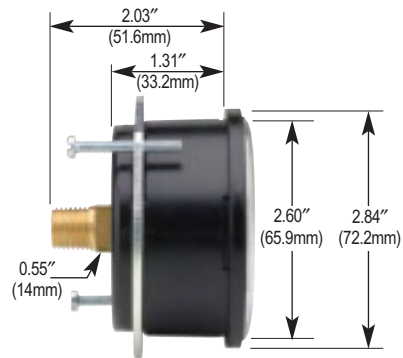

25-234

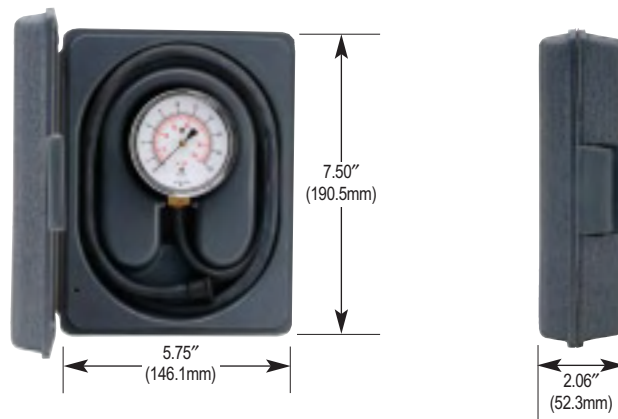

Dial Indicating Pressure Gauges

Brass Case Liquid Filled



300 SERIES

- High quality liquid filled gauges designed for durability, accuracy and long life
- Pressure ranges from vacuum through 15,000 psi
- 2-1/2 and 4 inch sizes – bottom or back connected
- Heavy one-piece die casting integrates the case, connection, movement and bourdon tube support into a solid unit to eliminate leakage
- Glycerine fill greatly reduces effects of vibration, pulsation and shock
- Dials are printed with bold UV resistant ink for ease of readability even after years of exposure to direct sunlight
- Stock availability

OPERATING SPECIFICATIONS

1. Working Pressure Limitations

a. Dynamic Pressure

The working pressure should be limited to 60% of the dial range for long service life.

b. Static Pressure

The working pressure, where no sharp fluctuations occur, should be limited to 90% of the dial range

2. Ambient Temperature

0°F to 160°F (-18°C to 71°C)

Please contact us for assistance in selecting the best fill for your application.

3. Media Temperature

-4°F to 140°F (-20°C to 60°C)

Optional temperature ratings available from -40°F to 212°F (-40°C to 100°C)

APPLICATIONS

- Used in demanding applications that are not corrosive to brass, where vibration and pulsation are present

ACCURACY

- 2-1/2 Inch 300 Series Gauges: ±1.5%
- 4 Inch 300 Series Gauges: ±1.0%

For details on accuracy/standard dial configuration and dial layouts, see pages 74-78

	MODELS	SPECIFICATIONS
Case	25-300, 25-310, 40-300, 40-310	Die cast brass – Natural brass finish
Cover Ring	25-300, 25-310, 40-300, 40-310	Polished brass
Lens	25-300, 25-310, 40-300, 40-310	Molded Plexiglass™ with O-Ring seal
Bourdon Tube	25-300, 25-310, 40-300, 40-310 (up to 600 psi)	Phosphor bronze "C" tube
	25-300, 25-310, 40-300, 40-310 (greater than 600 psi)	Coiled safety tube
Connection	25-300, 25-310	1/4" NPT die cast with the case. 7/16" – 20 SAE adjustable type straight thread with Viton O-Ring is also available as a stock option on many ranges (-4 SAE).
	40-300, 40-310	1/4" NPT die cast with the case. 1/2" NPT is available on certain 40-300 ranges as a stock option, and on all other 40-300 and 40-310's as a non-stock option.
Movement	25-300, 25-310, 40-300, 40-310	Brass and Nickel-Silver with highly polished bearing surfaces
Safety Protection	25-300, 25-310, 40-300, 40-310	Safety relief disc on the top of the case
Accuracy	25-300, 25-310	± 1.5% Full Scale ASME grade A
	40-300, 40-310	± 1% Full Scale ASME grade 1A
Pointer	25-300, 25-310, 40-300, 40-310	Balanced aluminum, black finish
Dial	25-300, 25-310, 40-300, 40-310	Aluminum, white background with black markings. Single scale psi is standard. psi/bar, psi/kPa, or psi/Kg/cm ² dual scale are available as stock options. On dual scale dials, the outer scale is psi in black and the inner metric scale is red. UV resistant.
Fill Liquid	25-300, 25-310, 40-300, 40-310	Glycerine and water

ORDERING INFORMATION								
SERIES	300							
SIZE	25 2-1/2 Inch		40 4 Inch					
CASE TYPE	300 Brass, Bottom Connection		310 Brass, Back Connection					
PRESSURE RANGES	30 " Vac	-30 inHg to 0	30/300	-30 inHg to 0 to 300 psi	300	0 psi to 300 psi	3000	0 psi to 3000 psi
	30/15	-30 inHg to 0 to 15 psi	15	0 psi to 15 psi	400	0 psi to 400 psi	5000	0 psi to 5000 psi
	30/30	-30 inHg to 0 to 30 psi	30	0 psi to 30 psi	600	0 psi to 600 psi	6000	0 psi to 6000 psi
	30/60	-30 inHg to 0 to 60 psi	60	0 psi to 60 psi	800	0 psi to 800 psi	7500	0 psi to 7500 psi
	30/100	-30 inHg to 0 to 100 psi	100	0 psi to 100 psi	1000	0 psi to 1000 psi	10000	0 psi to 10000 psi
	30/160	-30 inHg to 0 to 160 psi	160	0 psi to 160 psi	1500	0 psi to 1500 psi	15000	0 psi to 15000 psi
	30/200	-30 inHg to 0 to 200 psi	200	0 psi to 200 psi	2000	0 psi to 2000 psi		
SCALE OPTION	psi	psi single scale	psi/kPa	psi/kPa dual scale	psi/kg/cm ²	psi/kg/cm ² dual scale	psi/bar	psi/bar dual scale
CONNECTION SIZE	1/4	1/4" NPT	1/2	1/2" NPT	SST	7/16-20 Adjustable		
OPTIONS	CFF	Chrome front flange	CCR	Chrome cover ring	SGO	Safety Glass overlay	BT3	Brass threaded orifice 0.3 mm
	BFF	Brass front flange	CB-U	Chrome bezel & u-clamp	AR	Adapter ring	BT4	Brass threaded orifice 0.4 mm
	BLFF	Black front flange	MIP	Maximum indicating pointer	LM	Laser marking	BT8	Brass threaded orifice 0.8 mm
	SSRF	304SS rear flange	LL	Lexan lens	ST	Stainless steel tagging	7/16-20	Straight thread available
	BRF	Brass rear flange	GLO	Glass lens overlay				

Please consult your local NOSHOK Distributor or NOSHOK, Inc. for availability and delivery information.

NOTE: Refer to 300 Series Options & Accessories chart on page 65 for availability by model number.

EXAMPLE

1. Select model number (size & case type)
2. Select pressure range & scale option
3. Select connection size (if more than one is offered)
4. Select any required accessory or option

40-300 - 3000 psi - 1/2" - BRF

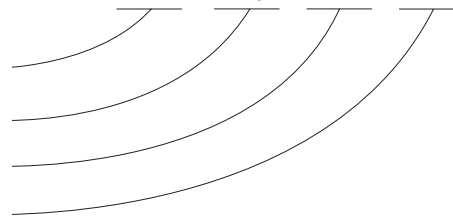

OUTLINE DIMENSIONS

25-300

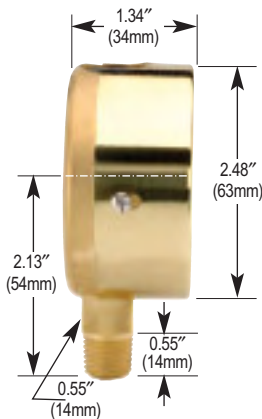

40-300

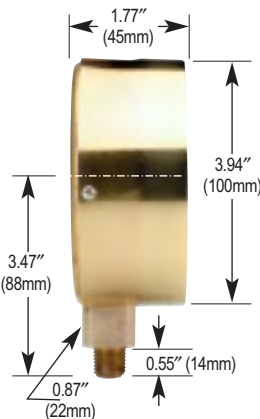

25-310

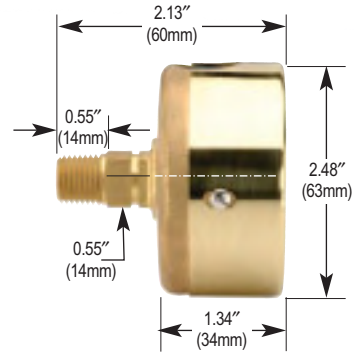

Dial Indicating Pressure Gauges

Dimensions

40-310

25-300 Front Flange

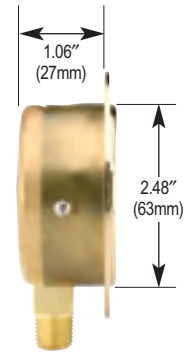
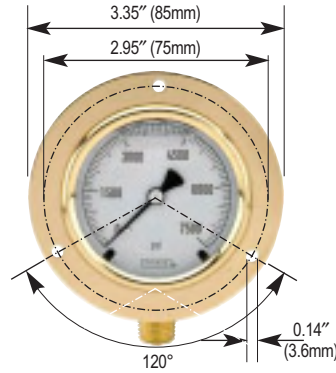
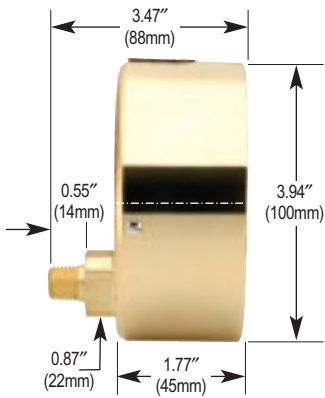

40-300 Front Flange

25-310 Front Flange

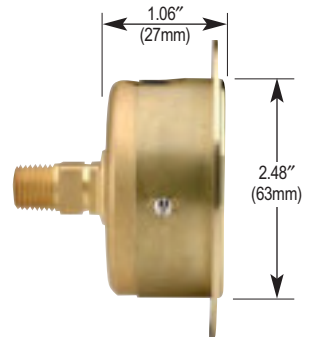
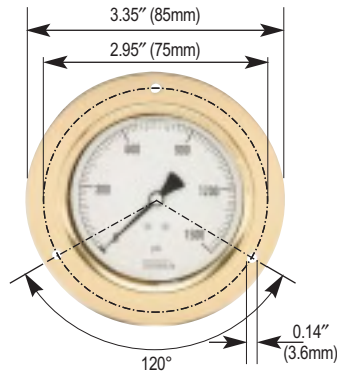
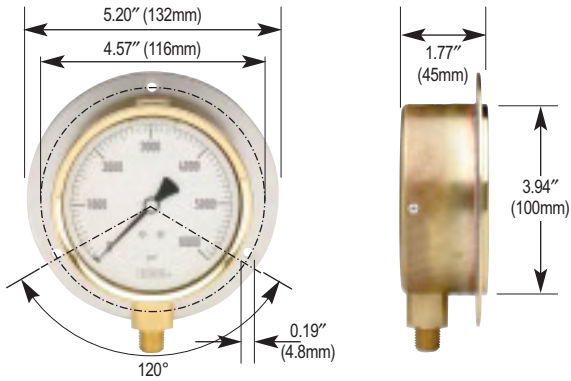

40-310 Front Flange

25-300 Rear Flange

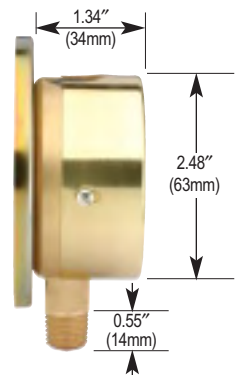
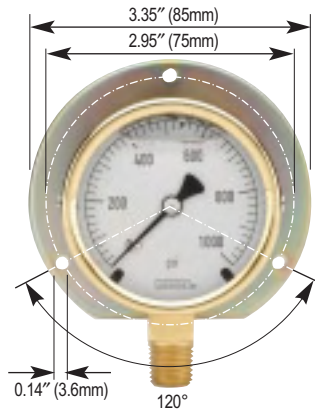
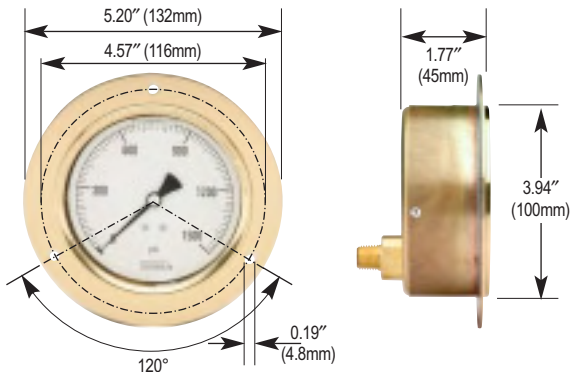

40-300 Rear Flange

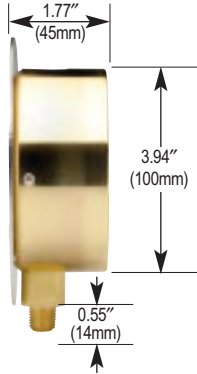
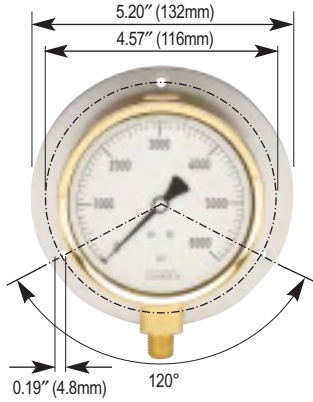

25-310 Rear Flange

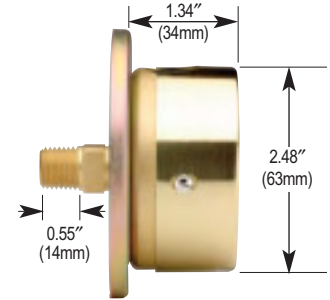
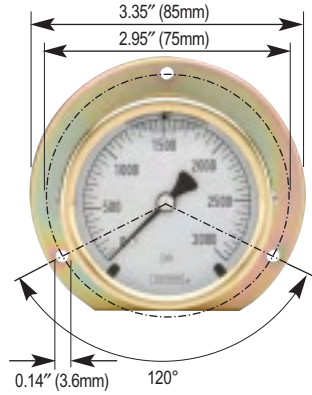

40-310 Rear Flange

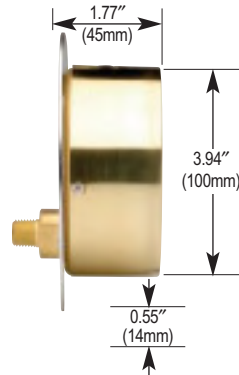
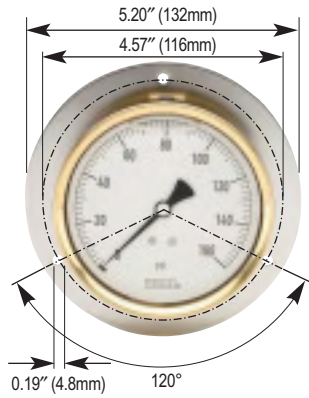

25-310 Chrome Triangular Bezel with U-Clamp

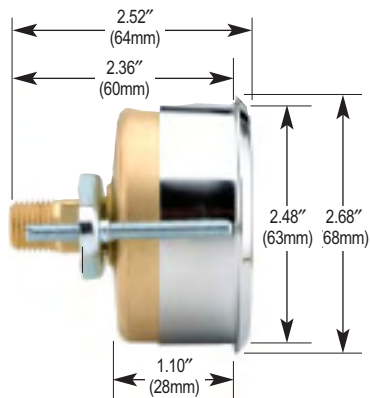

40-310 Chrome Triangular Bezel with U-Clamp

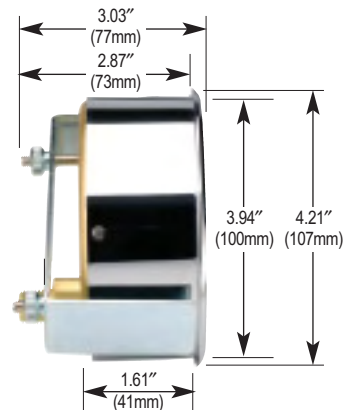

Stainless Steel

400/500 SERIES



- The ultimate corrosion resistant heavy-duty vacuum and pressure gauges
- **Extreme high pressure** ranges available from vacuum through 100,000 psi
- 1-1/2, 2, 2-1/2, 4 and 6 inch sizes – bottom or back connected
- Cases and polished bezels are constructed of solid 304 Stainless steel, with 316 Stainless steel internals
- Vacuum, compound and zero based ranges
- Bourdon tubes are matched to Stainless steel precision movements and balanced pointers for smooth, accurate indication
- Glycerine filling (in the 500 Series) further enhances gauge life by constantly lubricating the movement and dampening the effects of vibration, pulsation and shock.
- NOSHOK's Agriculture Ammonia Gauges (25-406 and 25-506) feature a nickel-plated brass connection with a 316 Stainless steel Bourdon Tube
- Stock availability

OPERATING SPECIFICATIONS

1. Working Pressure Limitations

a. Dynamic Pressure

The working pressure should be limited to 60% of the dial range for long service life.

b. Static Pressure

The working pressure, when no sharp fluctuations occur, should be limited to 90% of the dial range.

2. Ambient Temperature

a. 400 Series

-40°F to 140°F (-40°C to 60°C)

b. 500 Series

-4°F to 140°F (-20°C to 60°C)

Glycerine Fill

-40°F to 140°F (-40°C to 60°C)

Special Fill

3. Media Temperature

a. 400 Series

-40°F to 212°F (-40°C to 100°C)

1-1/2" and 2-1/2" sizes

-40°F to 392°F (-40°C to 200°C)

4" and 6" sizes

b. 500 Series

-4°F to 212°F (-20°C to 100°C)

Glycerine Fill

-40°F to 212°F (-40°C to 100°C)

Special Fill

APPLICATIONS

- Chemical plants
- Petrochemical refineries
- Pharmaceutical
- Food and beverage processing
- Offshore oil platforms
- Paper mills
- Salt mines
- Fertilizer plants
- Shipboard

ACCURACY

- 1-1/2 inch 400 Series Gauges: ±2.5%
- 2-1/2 inch 400 Series Gauges: ±1.5%
- 4 and 6 inch 400 Series Gauges: ±1.0%
- 2-1/2 inch 500 Series Gauges: ±1.5%
- 4 and 6 inch 500 Series Gauges: ±1.0%

	MODELS	SPECIFICATIONS
Case	15-400, 15-410, 40-400, 40-410, 60-400, 60-410, 60-500, 60-510	304 Stainless steel
	25-400, 25-410, 25-500, 25-510, 40-500, 40-510	Polished 304 Stainless steel
Cover Ring	15-400, 15-410, 25-400, 25-410, 25-500, 25-510, 40-400, 40-410, 40-500, 40-510	Polished 304 Stainless steel
	60-400, 60-410, 60-500, 60-510	Polished 304 Stainless steel bayonet ring
Lens	15-400, 15-410, 40-400, 40-410, 40-500, 40-510	Instrument glass
	25-400, 25-410, 25-500, 25-510	Trogamide
	60-400, 60-410, 60-500, 60-510	Laminated safety glass
Bourdon Tube	15-400, 15-410, 25-400, 25-410, 25-500, 25-510, 40-400, 40-410, 40-500, 40-510, 60-400, 60-410, 60-500, 60-510 (up to 600 psi)	316 Stainless steel "C" tube
	25-400, 25-410, 25-500, 25-510, 40-400, 40-410, 40-500, 40-510, 60-400, 60-410, 60-500, 60-510 (greater than 600 psi)	Coiled safety tube
Connection	15-400, 15-410	1/8" NPT, 316 Stainless steel
	25-400, 25-410, 25-500, 25-510	1/4" NPT, 316 Stainless steel
	40-400, 40-410, 40-500, 40-510, 60-400, 60-410, 60-500, 60-510	1/2" NPT, 316 Stainless steel. 9/16" – 18 high pressure connections are standard on 0 – 30,000 PSI and higher
Movement	15-400, 15-410, 25-400, 25-410, 25-500, 25-510	Stainless steel and nylon with highly polished bearing surfaces
	40-400, 40-410, 40-500, 40-510	All Stainless steel with internal zero stop and highly polished bearing surfaces
	60-400, 60-410, 60-500, 60-510	Stainless steel with highly polished bearing surfaces. An internal zero stop is standard.
Safety Protection	25-400, 25-410, 25-500, 25-510	Safety relief disc on the top of the case
	40-400, 40-410, 40-500, 40-510, 60-400, 60-410, 60-500, 60-510	Safety relief disc on the back and top of the case
Accuracy	15-400, 15-410	± 2.5% Full Scale ASME grade B
	25-400, 25-410, 25-500, 25-510	± 1.5% Full Scale ASME grade A
	40-400, 40-410, 40-500, 40-510, 60-400, 60-410, 60-500, 60-510	± 1% Full Scale ASME grade 1A
Pointer	15-400, 15-410	Black finished aluminum
	25-400, 25-410, 25-500, 25-510, 40-400, 40-410, 40-500, 40-510	Balanced aluminum, black finish
	60-400, 60-410, 60-500, 60-510	Balanced micro-adjustable aluminum, black finish
Dial	15-400, 15-410	Aluminum, white background with black markings. Single scale psi. UV resistant
	25-400, 25-410, 25-500, 25-510, 40-400, 40-410, 40-500, 40-510, 60-400, 60-410, 60-500, 60-510	Aluminum, white background with black markings. Single scale psi is standard. psi/bar, psi/kPa, or psi/Kg/cm ² dual scale are available as stock options. On dual scale dials, the outer scale is psi in black and the inner metric scale is red. UV resistant.
Fill Liquid	25-500, 25-510, 40-500, 40-510, 60-500, 60-510	Glycerine and water

ORDERING INFORMATION													
SERIES	400/500												
SIZE	15	1-1/2 Inch		25	2-1/2 Inch		40	4 Inch		60	6 Inch		
CASE TYPE	400	All SS, Dry/Fillable, Bottom Connection			410	All SS, Dry/Fillable, Back Connection			506	Ammonia, Liquid Filled, Bottom Connection			
	401	All SS, Dry, Bottom Connection			411	All SS, Dry, Back Connection			510	SS Case, Liquid Filled, Back Connection			
	406	Ammonia, Dry/Fillable, Bottom Connection			500	SS Case, Liquid Filled, Bottom Connection							
PRESSURE RANGES	30 " Vac	-30 inHg to 0			15	0 psi to 15 psi		600	0 psi to 600 psi		10000	0 psi to 10000 psi	
	30/15	-30 inHg to 0 to 15 psi			30	0 psi to 30 psi		800	0 psi to 800 psi		15000	0 psi to 15000 psi	
	30/30	-30 inHg to 0 to 30 psi			60	0 psi to 60 psi		1000	0 psi to 1000 psi		20000	0 psi to 20000 psi	
	30/60	-30 inHg to 0 to 60 psi			100	0 psi to 100 psi		1500	0 psi to 1500 psi		30000	0 psi to 30000 psi	
	30/100	-30 inHg to 0 to 100 psi			160	0 psi to 160 psi		2000	0 psi to 2000 psi		40000	0 psi to 40000 psi	
	30/160	-30 inHg to 0 to 160 psi			200	0 psi to 200 psi		3000	0 psi to 3000 psi		60000	0 psi to 60000 psi	
	30/200	-30 inHg to 0 to 200 psi			300	0 psi to 300 psi		5000	0 psi to 5000 psi		80000	0 psi to 80000 psi	
	30/300	-30 inHg to 0 to 300 psi			400	0 psi to 400 psi		6000	0 psi to 6000 psi		100000	0 psi to 100000 psi	
	SCALE OPTION	psi	psi single scale		psi/kPa	psi/kPa dual scale		psi/kg/cm ²	psi/kg/cm ² dual scale		psi/bar	psi/bar dual scale	
CONNECTION SIZE	1/4	1/4" NPT		1/2	1/2" NPT		9/16-18	9/16-18 UNF 3B*					
OPTIONS	SSFF	304SS front flange			SSFR	304SS flange ring			SP	Red set pointer			
	SSRF	304SS rear flange			FR	Flange ring			LM	Laser marking			
	SSB-U	Stainless steel bezel & U-clamp			AP	Adjustable pointer			ST	Stainless steel tagging			
	SPMC	304SS panel mount clamp			SGL	Safety glass lens			ST5	Stainless steel threaded orifice 0.5 mm			
	PMC	Steel panel mount clamp			MIP	Maximum indicating pointer			ST8	Stainless steel threaded orifice 0.8 mm			

Please consult your local NOSHOK Distributor or NOSHOK, Inc. for availability and delivery information.

NOTE: Refer to 400/500 Series Options & Accessories chart on page 66 for availability by model number.

*Connection size for pressures 30,000 psi and above.

EXAMPLE

1. Select model number (size & case type)
2. Select pressure range & scale option
3. Select connection size (if more than one is offered)
4. Select any required accessory or option

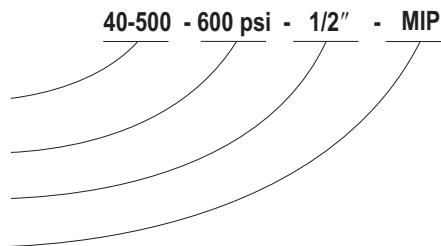

OUTLINE DIMENSIONS

15-401

25-400/500

40-400/500

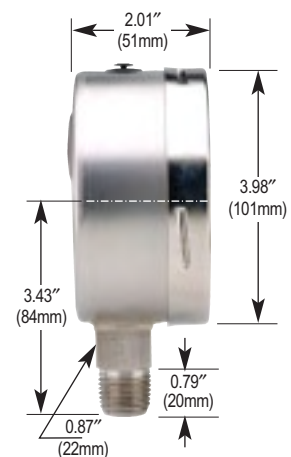
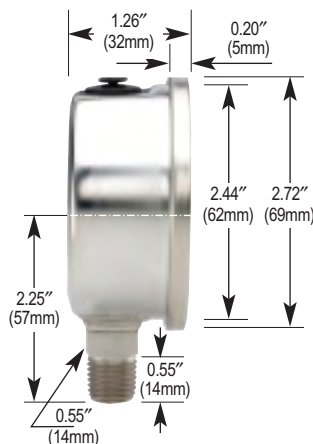
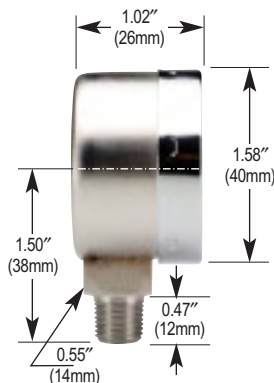

Dial Indicating Pressure Gauges

Dimensions

60-400/500

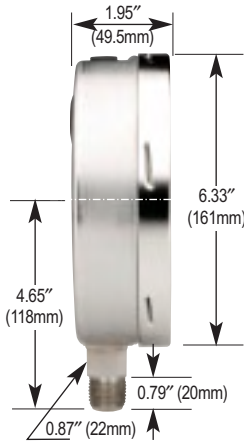

15-411

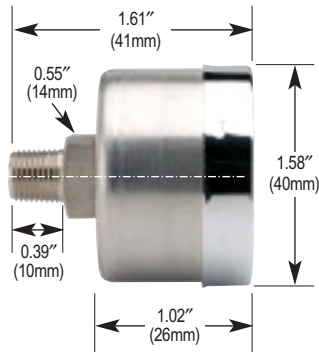

25-410/510

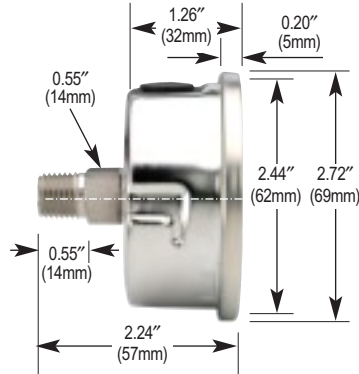

40-410/510

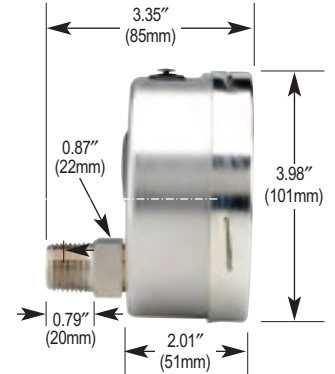

60-410/510

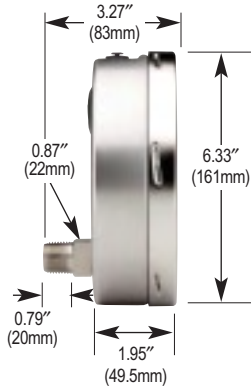

40-400/500 Front Flange



60-400/500 Front Flange

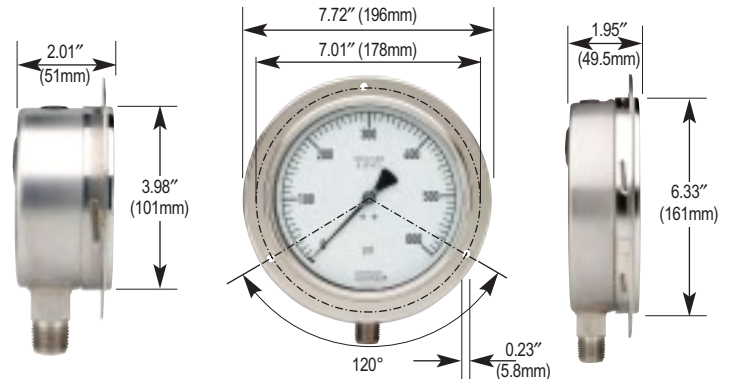

25-410/510 Front Flange

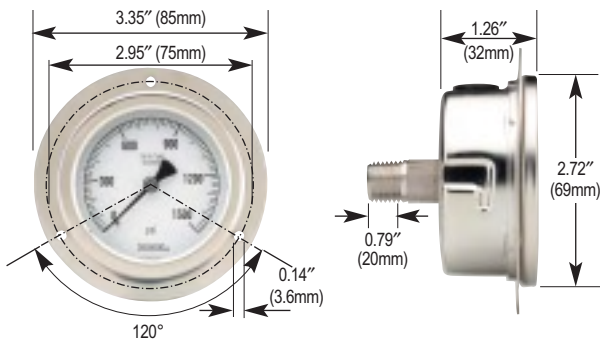

40-410/510 Front Flange

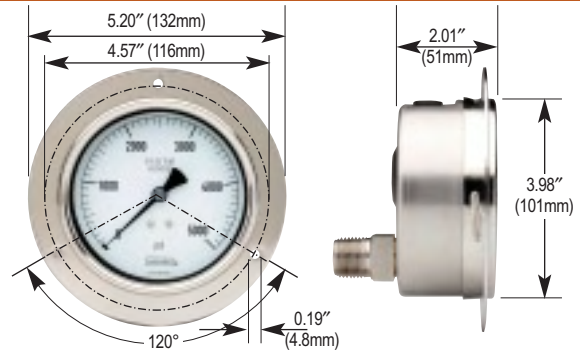

60-410/510 Front Flange

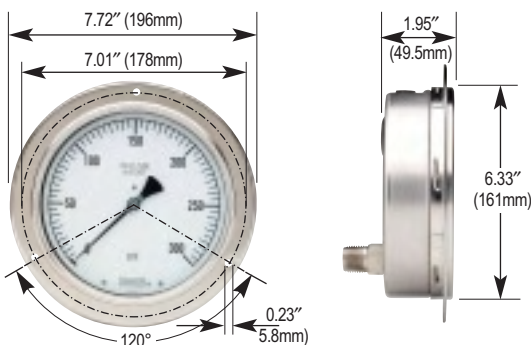

40-400/500 Rear Flange

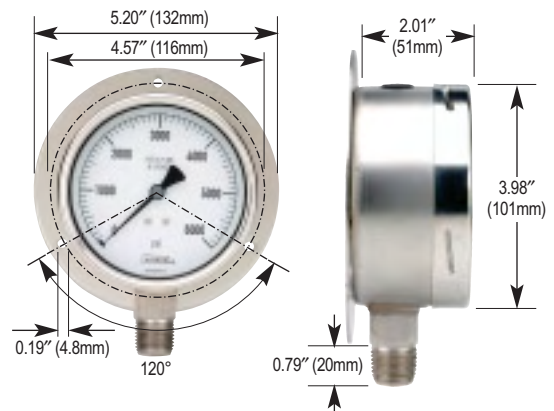

400/500 SERIES DIMENSIONS

60-400/500 Rear Flange

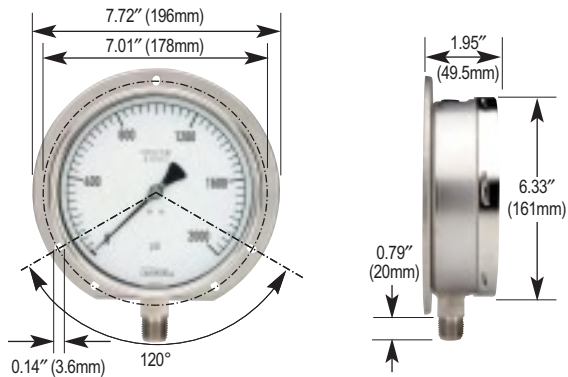

40-410/510 Rear Flange

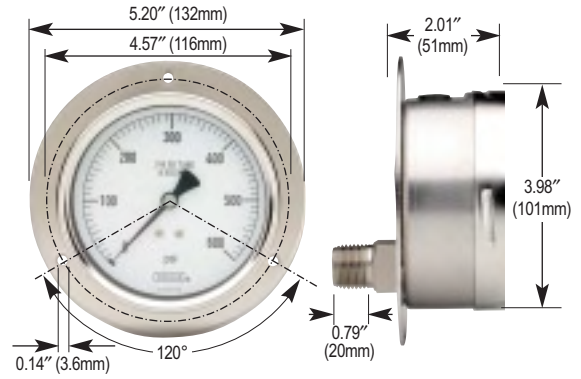

60-410/510 Rear Flange

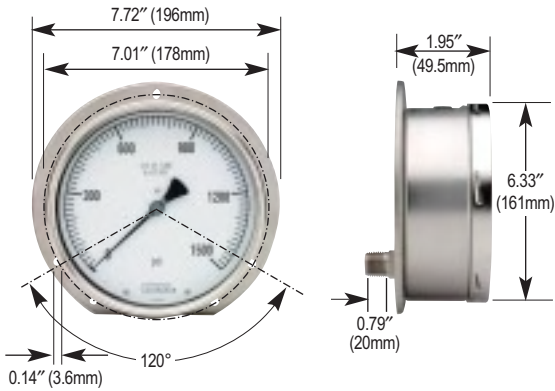

25-410/510 Flange Ring

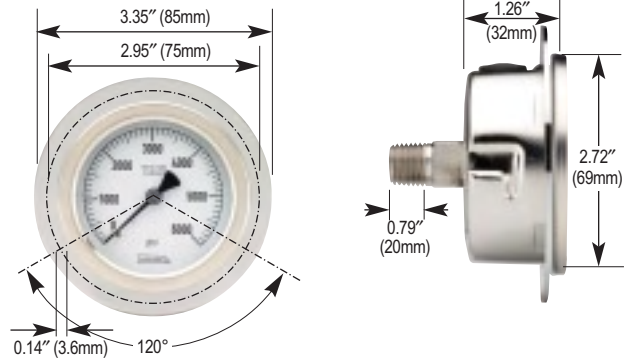

25-410/510 Panel Mount Clamp

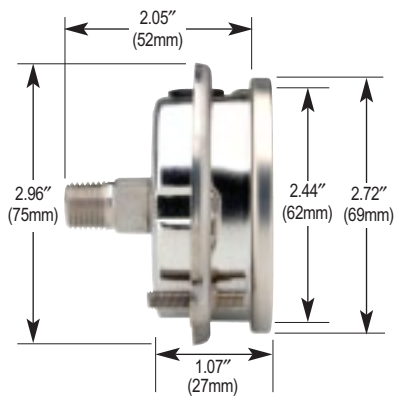

40-410/510 SS Narrow Bezel w/U-Clamp

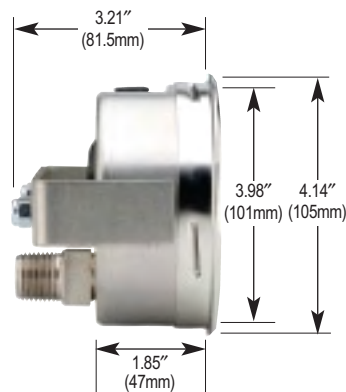

60-410/510 SS Narrow Bezel w/U-Clamp

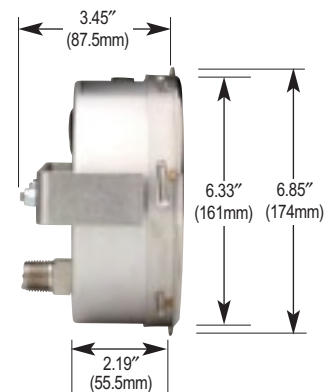

Process



600/700 SERIES

- 600 (Brass) and 700 (316 Stainless steel) Gauges are specifically designed for demanding applications in the chemical and petroleum processing industries
- **Extreme high pressure** ranges available from vacuum through 60,000 psi
- Low pressure ranges from -30 inH₂O vac through 10 psi
- 4-1/2 inch size – bottom connected
- Turret style cases are constructed of a rugged, corrosion-resistant phenolic material
- Solid front, safety case with a blow-out back isolates the gauge face from the pressure
- Adjustable pointer
- Standard lenses are shatter resistant acrylic; safety glass lenses available
- Stock availability

OPERATING SPECIFICATIONS

1. Working Pressure Limitations

a. Dynamic Pressure

The working pressure should be limited to 60% of the dial range.

b. Static Pressure

The working pressure, when no sharp fluctuations occur, should be limited to 90% of the dial range.

2. Ambient Temperature

a. 640/740 Series

-40°F to 150°F (-40°C to 65°C)

b. 660/760 Series

-4°F to 150°F (-20°C to 65°C) Glycerine Fill

-40°F to 150°F (-40°C to 65°C) Special Fill

3. Media Temperature

a. 640 Series

-4°F to 150°F (-20°C to 65°C)

b. 660 Series

-4°F to 150°F (-20°C to 65°C) Glycerine Fill

-40°F to 150°F (-40°C to 65°C) Special Fill

c. 740 Series

-40°F to 212°F (-40°C to 100°C)

500°F (260°C)

Maximum for short term/intermittent

d. 760 Series

-4°F to 212°F (-20°C to 100°C) Glycerine Filled

-40°F to 212°F (-40°C to 100°C) Special Fill

250°F (130°C) Maximum for short term/intermittent

APPLICATIONS

- Chemical petroleum and petrochemical refineries
- Utilities
- Food processing plants
- Paper mills
- Power generating stations
- Water treatment plants
- Wherever accuracy, safety, readability and reliability are crucial

ACCURACY

- 4-1/2 inch 600 Series Gauges: ±0.5%
- 4-1/2 inch 700 Series Gauges: ±0.5%
- 4-1/2 inch 700 Series Gauges (LP): ±1.5%

	MODELS	SPECIFICATIONS
Case	45-640, 45-660, 45-740, 45-760	Turret style black phenolic. Solid front, safety case with blow-out back
Bayonet Ring	45-640, 45-660, 45-740, 45-760	Thread black phenolic
Lens	45-640, 45-660, 45-740, 45-760	Acrylic. Laminated safety glass is available as a stock option
Bourdon Tube	45-640, 45-660 (up to 600 psi)	Beryllium copper "C" tube
	45-740, 45-760 (up to 600 psi)	316 Stainless steel "C" Tube
Connection	45-640, 45-660	1/4" NPT brass
	45-740, 45-760	1/4" NPT or 1/2" NPT 316 Stainless steel
Movement	45-640, 45-660	Brass and Nickel-Silver with highly polished bearing surfaces. An internal zero stop is standard.
	45-740, 45-760	Stainless steel with highly polished bearing surfaces. An internal zero stop is standard.
Safety Protection	45-640, 45-660, 45-740, 45-760	Blow-out back on the rear of case.
Accuracy	45-640, 45-660	± 1/2% Full Scale ASME grade 2A
	45-740, 45-760	± 1/2% Full Scale ASME grade 2A. ± 1.5% Full Scale ASME grade A for inH ₂ O, 5 psi and 10 psi ranges
Pointer	45-640, 45-660, 45-740, 45-760	Balanced micro-adjustable aluminum, black finish
Dial	45-640, 45-660, 45-740, 45-760	Aluminum, white background with black markings. Single scale psi is standard. psi/bar, psi/kPa, or psi/Kg/cm ² dual scale are available as stock options. On dual scale dials, the outer scale is psi in black and the Inner metric scale is red. UV resistant.
Fill Liquid	45-660, 45-760	Glycerine and water. Silicone and halocarbon are available as options.

For details on accuracy/standard dial configuration and dial layouts, see pages 74-78

ORDERING INFORMATION										
SERIES	600/700									
SIZE	45 4-1/2 Inch									
CASE TYPE	640 Brass, Dry, Bottom Connection 740 SS, Dry, Bottom Connection					660 Brass, Liquid Filled, Bottom Connection 760 SS, Liquid Filled, Bottom Connection				
PRESSURE RANGES	30 inH ₂ O vac	-30 inH ₂ O to 0 inH ₂ O	30" vac	-30 inHg to 0	5	0 psi to 5 psi	300	0 psi to 300 psi	5000	0 psi to 5000 psi
	60 inH ₂ O vac	-60 inH ₂ O to 0 inH ₂ O	30/15	-30 inHg to 0 to 15 psi	10	0 psi to 10 psi	400	0 psi to 400 psi	6000	0 psi to 6000 psi
	60/60 inH ₂ O	-60 inH ₂ O to 60 inH ₂ O	30/30	-30 inHg to 0 to 30 psi	15	0 psi to 15 psi	600	0 psi to 600 psi	10000	0 psi to 10000 psi
	60 inH ₂ O	0 inH ₂ O to 60 inH ₂ O	30/60	-30 inHg to 0 to 60 psi	30	0 psi to 30 psi	800	0 psi to 800 psi	15000	0 psi to 15000 psi
	100 inH ₂ O	0 inH ₂ O to 100 inH ₂ O	30/100	-30 inHg to 0 to 100 psi	60	0 psi to 60 psi	1000	0 psi to 1000 psi	20000	0 psi to 20000 psi
	160 inH ₂ O	0 inH ₂ O to 160 inH ₂ O	30/160	-30 inHg to 0 to 160 psi	100	0 psi to 100 psi	1500	0 psi to 1500 psi	30000	0 psi to 30000 psi
	200 inH ₂ O	0 inH ₂ O to 200 inH ₂ O	30/200	-30 inHg to 0 to 200 psi	160	0 psi to 160 psi	2000	0 psi to 2000 psi	40000	0 psi to 40000 psi
	300 inH ₂ O	0 inH ₂ O to 300 inH ₂ O	30/300	-30 inHg to 0 to 300 psi	200	0 psi to 200 psi	3000	0 psi to 3000 psi	60000	0 psi to 60000 psi
SCALE OPTION	inH ₂ O	inH ₂ O single scale	psi	psi single scale	psi/kPa	psi/kPa dual scale	psi/kg/cm ²	psi/kg/cm ² dual scale	psi/bar	psi/bar dual scale
CONNECTION SIZE	1/4	1/4" NPT	1/2	1/2" NPT	9/16-18 9/16-18 UNF 3B (above 30000 psi standard)					
OPTIONS	SGL	Safety glass lens	CPMR	Uninstalled chrome panel mount ring	ST	Stainless steel tagging				
	GL	Glass lens	MDM	Manocont dampened movement	BP3	Brass press fit orifice 0.3 mm				
	MIP	Maximum indicating pointer	OS	Overload stop	BT3	Brass threaded orifice 0.3 mm				
	BPMR	Uninstalled black panel mount ring	LM	Laser marking	ST8	316SS threaded orifice 0.8 mm				

Please consult your local NOSHOK Distributor or NOSHOK, Inc. for availability and delivery information.

NOTE: Refer to 600/700 Series Options & Accessories chart on page 66 for availability by model number.

EXAMPLE

1. Select model number (size & case type)
2. Select pressure range & scale option
3. Select connection size (if more than one is offered)
4. Select any required accessory or option

45-740 - 100 psi - 1/2" - BT8

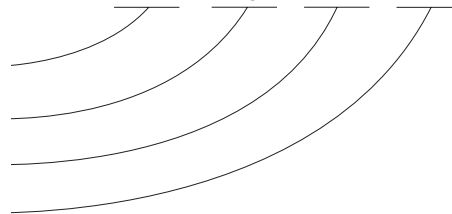

OUTLINE DIMENSIONS

45-640/660 & 45-740/760

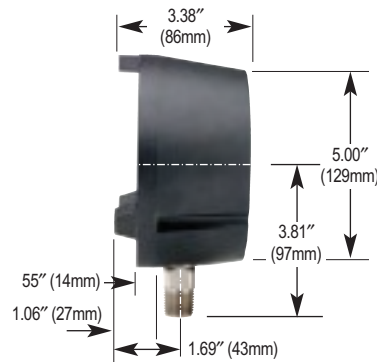
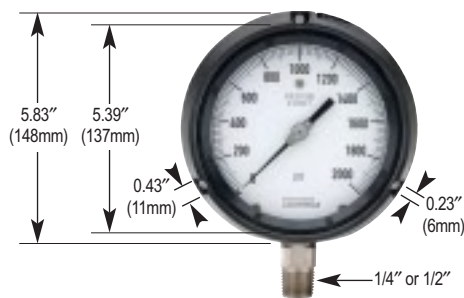

45-640/660 & 45-740/760 Panel Mount Ring

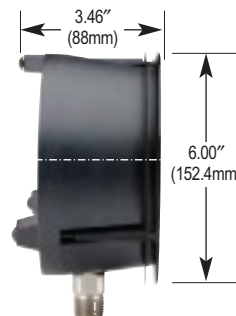
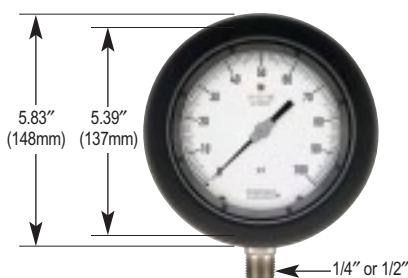

Precision Test



800 SERIES

- Meet the specification of ASME Standard B40.1 Grade 3A
- Ranges available vacuum through 20,000 psi
- +/-0.25% accuracy to 100% of dial range on rising or falling pressure
- 6 inch size – bottom connected
- Adjustable knife-edge pointer and mirrored dial eliminate parallax error*
- Brass or 316 Stainless steel wetted parts
- Safety blow-out disc on the rear case is standard
- Instrument glass lens and 304 Stainless steel case
- Jeweled brass and nickel silver bearings and movement
- Panel mountable, optional carrying case
- Stock availability

*The difference in apparent direction of an object as seen from two different points not on a straight line with the object

OPERATING SPECIFICATIONS

1. Working Pressure Limitations

Static Pressure

The working pressure, when no sharp fluctuations occur, should be limited to 100% of the dial range.

NOTE: 800 Series Test Gauges are not intended for dynamic applications.

2. Ambient Temperature

-40°F to 140°F (-40°C to 60°C)

3. Media Temperature

-40°F to 180°F (-40°C to 80°C)

APPLICATIONS

- Laboratories on calibration test stands
- Sophisticated aerospace equipment used in launching space vehicles
- Gauge repair facilities
- Wherever high accuracy and sensitivity are critical

	MODELS	SPECIFICATIONS
Case	60-800	304 Stainless steel
Cover	60-800	304 Stainless steel
Lens	60-800	Instrument glass
Bourdon Tube	60-800	Beryllium copper to 1000 psi 316 SS 1500 psi to 10000 psi NI Span C 15000 psi to 20000 psi
Connection	60-800	1/4 " NPT bottom connection 1/2 " NPT bottom connection for 20000 psi
Movement	60-800	Brass with jeweled bearings nickel-silver pinion gear and shafts
Safety Protection	60-800	Safety relief disc on the back of the case
Accuracy	60-800	± 0.25% Full Scale ASME grade 3A
Pointer	60-800	Adjustable knife-edge pointer
Dial	60-800	Aluminum, white mirrored background with black graduations

For details on accuracy/standard dial configuration and dial layouts, see pages 74-78

ORDERING INFORMATION								
SERIES	800							
SIZE	60 6 Inch							
CASE TYPE	800 SS Case, Bottom Connection							
PRESSURE RANGES	30 " Vac	-30 inHg to 0	30/300	-30 inHg to 0 to 300 psi	300	0 psi to 300 psi	5000	0 psi to 5000 psi
	30/15	-30 inHg to 0 to 15 psi	15	0 psi to 15 psi	400	0 psi to 400 psi	6000	0 psi to 6000 psi
	30/30	-30 inHg to 0 to 30 psi	30	0 psi to 30 psi	600	0 psi to 600 psi	10000	0 psi to 10000 psi
	30/60	-30 inHg to 0 to 60 psi	60	0 psi to 60 psi	1000	0 psi to 1000 psi	15000	0 psi to 15000 psi
	30/100	-30 inHg to 0 to 100 psi	100	0 psi to 100 psi	1500	0 psi to 1500 psi	20000	0 psi to 20000 psi
	30/160	-30 inHg to 0 to 160 psi	160	0 psi to 160 psi	2000	0 psi to 2000 psi		
	30/200	-30 inHg to 0 to 200 psi	200	0 psi to 200 psi	3000	0 psi to 3000 psi		
SCALE OPTION	psi psi single scale							
CONNECTION SIZE	1/4	1/4" NPT	1/2	1/2" NPT (standard for 20000 psi)				
OPTIONS	SSFF	304SS front flange	ST	Stainless steel tagging				
	SSRF	304SS rear flange	BP3	Brass press fit orifice 0.3 mm (below 10,000 psi)				
	CC	Carrying case	BT8	Brass threaded orifice 0.8 mm (below 10,000 psi)				
	LM	Laser marking	ST8	316SS threaded orifice 0.8 mm (10,000 – 20,000 psi)				

Please consult your local NOSHOK Distributor or NOSHOK, Inc. for availability and delivery information.

NOTE: Refer to 800 Series Options & Accessories chart on page 67 for availability by model number.

EXAMPLE

1. Select model number (size & case type)
2. Select pressure range
3. Select connection size (if more than one is offered)
4. Select any required accessory or option

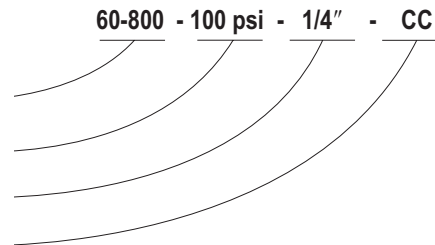

OUTLINE DIMENSIONS

60-800*

60-800 Front Flange

60-800 Rear Flange

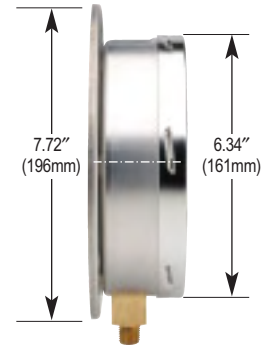
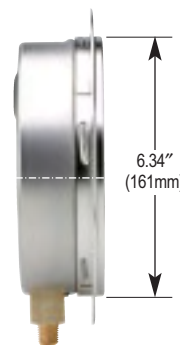
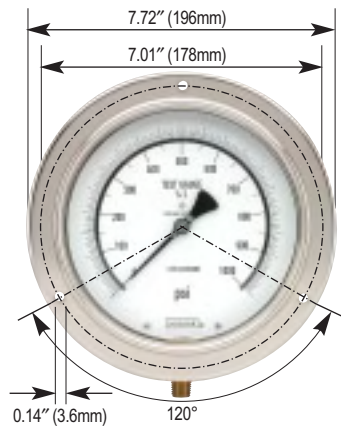
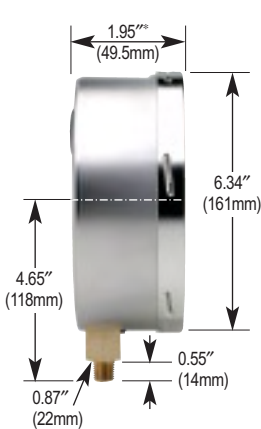

*For ranges ≤60 psi and ≥1,500 psi, depth dimension changes to 2.58" (65.5mm)

Dial Indicating Pressure Gauges

ABS & Stainless Steel Liquid Filled



900 SERIES

- Extremely high quality pressure gauges, liquid filled for extended service life and shock resistance
- Ranges available from vacuum to 15,000 psi
- 1-1/2, 2, 2-1/2, 4 inch sizes – bottom or back connected
- Lightweight shatter-resistant ABS or 304 Stainless steel case, Plexiglass™ lens for extra strength
- Unique o-ring case and connection seals guard against leakage and protect against shock and vibration
- Relief disc on top or back provides positive case relief
- Brass and copper alloy movement
- High grade Glycerine fill dampens the effects of pulsation, vibration and shock loads, and provides lubrication of the movement
- Volume oriented
- Stock availability

OPERATING SPECIFICATIONS

1. Working Pressure Limitations

a. Dynamic Pressure

The working pressure should be limited to 60% of the dial range

b. Static Pressure

The working pressure, when no sharp fluctuations occur, should be limited to 90% of the dial range.

2. Ambient Temperature

-4°F to 140°F (-20°C to 60°C) Glycerine Fill

-40°F to 140°F (-40°C to 60°C) Special Fill

3. Media Temperature

-4°F to 140°F (-20°C to 60°C) Glycerine Fill

-40°F to 140°F (-40°C to 60°C) Special Fill

APPLICATIONS

- Industrial applications where pulsation, vibration and shock are present

ACCURACY

- 1-1/2 and 2 inch 900 Series Gauges: $\pm 2.5\%$
- 2-1/2 inch 900 Series Gauges: $\pm 1.5\%$
- 4 inch 900 Series Gauges: $\pm 1.0\%$

For details on accuracy/standard dial configuration and dial layouts, see pages 74-78

	MODELS	SPECIFICATIONS
Case	15-910, 25-900, 25-910	ABS (Acryl Nitril Butadien Styrol)
	25-901, 25-911, 40-901, 40-911	304 Stainless steel
Bezel	25-901, 25-911, 40-901, 40-911	304 Stainless steel
Lens	15-910, 25-900, 25-910	Plexiglass™; ultrasonically welded to the case
	25-901, 25-911	Polycarbonate
	40-901, 40-911	Instrument glass
Bourdon Tube	15-910, 25-900, 25-910, 25-901, 25-911, 40-901, 40-911 (up to 600 psi)	Phosphor bronze "C" tube
	15-910, 25-900, 25-910, 25-901, 25-911, 40-901, 40-911 (greater than 600 psi)	Coiled safety tube
Connection	15-910	1/8" NPT brass
	25-900, 25-910, 25-901, 25-911, 40-901, 40-911	1/4" NPT brass
	40-901, 40-911	1/4" NPT brass or 1/2" NPT brass
Movement	15-910, 25-900, 25-910, 25-901, 25-911, 40-901, 40-911	Brass and nylon with highly polished bearing surfaces
Safety Protection	15-910	Safety relief disc on the back of the case
	25-900, 25-910, 25-901, 25-911, 40-901, 40-911	Safety relief disc on the top of the case
Accuracy	15-910, 20-901, 20-911	$\pm 2.5\%$ Full Scale ASME grade B
	25-900, 25-910, 25-901, 25-911	$\pm 1.5\%$ Full Scale ASME grade A
	40-901, 40-911	$\pm 1\%$ Full Scale ASME grade 1A
Pointer	15-910, 25-900, 25-910, 25-901, 25-911	Molded plastic
	40-901, 40-911	Balanced aluminum, black finish
Dial	15-910, 25-900, 25-910	Molded plastic, white background with black psi scale and red kPa scale. UV resistant
	25-901, 25-911, 40-901, 40-911	Aluminum, white background, dual scale psi – kPa. black psi scale and Red kPa scale. UV resistant
Fill Liquid	15-910, 25-900, 25-910, 25-901, 25-911, 40-901, 40-911	Glycerine and water

ORDERING INFORMATION								
SERIES	900							
SIZE	15	1-1/2 Inch	20	2 Inch	25	2-1/2 Inch	40	4 Inch
CASE TYPE	900	ABS Case, Liquid Filled, Bottom Connection			910	ABS Case, Liquid Filled, Back Connection		
	901	SS Case, Liquid Filled, Bottom Connection			911	SS Case, Liquid Filled, Back Connection		
PRESSURE RANGES	30 " Vac	-30 inHg to 0	30/300	-30 inHg to 0 to 300 psi	300	0 psi to 300 psi	3000	0 psi to 3000 psi
	30/15	-30 inHg to 0 to 15 psi	15	0 psi to 15 psi	400	0 psi to 400 psi	5000	0 psi to 5000 psi
	30/30	-30 inHg to 0 to 30 psi	30	0 psi to 30 psi	600	0 psi to 600 psi	6000	0 psi to 6000 psi
	30/60	-30 inHg to 0 to 60 psi	60	0 psi to 60 psi	800	0 psi to 800 psi	7500	0 psi to 7500 psi
	30/100	-30 inHg to 0 to 100 psi	100	0 psi to 100 psi	1000	0 psi to 1000 psi	10000	0 psi to 10000 psi
	30/160	-30 inHg to 0 to 160 psi	160	0 psi to 160 psi	1500	0 psi to 1500 psi	15000	0 psi to 15000 psi
	30/200	-30 inHg to 0 to 200 psi	200	0 psi to 200 psi	2000	0 psi to 2000 psi		
SCALE OPTION	psi	psi single scale	psi/kPa	psi/kPa dual scale	psi/kg/cm ²	psi/kg/cm ² dual scale	psi/bar	psi/bar dual scale
CONNECTION SIZE	1/8	1/8" NPT	1/4	1/4" NPT	1/2	1/2" NPT		
OPTIONS	CFR	Chrome flange ring	CCR	Chrome cover ring	CFF	Chrome front flange	ST	Stainless steel tagging
	SSFR	304SS flange ring	SSCR	304SS cover ring	SSFF	304SS front flange	BP3	Brass press fit orifice 0.3 mm
	PMC	Steel panel mount clamp	MIP	Maximum indicating pointer	SSRF	304SS rear flange	BT5	Brass threaded orifice 0.5 mm
	SPMC	304SS panel mount clamp	AP	Adjustable pointer	BCR	Black cover ring	BT8	Brass threaded orifice 0.8 mm
	SSB-U	Stainless steel bezel & u-clamp	SGL	Safety glass lens	LM	Laser marking	7/16"-20	Straight thread available*
	SSB	Stainless steel bezel	BLFF	Black front flange				

Please consult your local NOSHOK Distributor or NOSHOK, Inc. for availability and delivery information.

NOTE: Refer to 900 Series Options & Accessories chart on page 67 for availability by model number.

* Includes Viton® O-Ring

EXAMPLE

1. Select model number (size & case type)
2. Select pressure range & scale option
3. Select connection size (if more than one is offered)
4. Select any required accessory or option

25-910 - 1000 psi/kPa - 1/4" - PMC

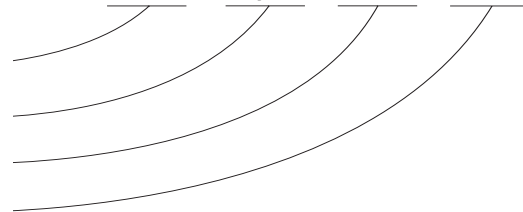

OUTLINE DIMENSIONS

25-900

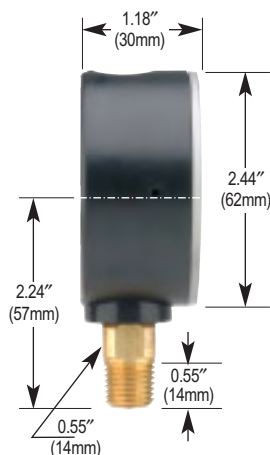

25-901

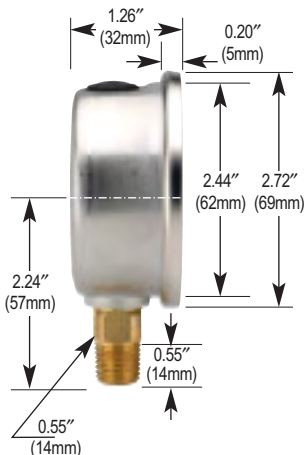

40-901

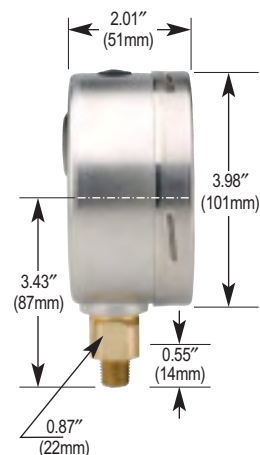

Dial Indicating Pressure Gauges

Dimensions

15-910

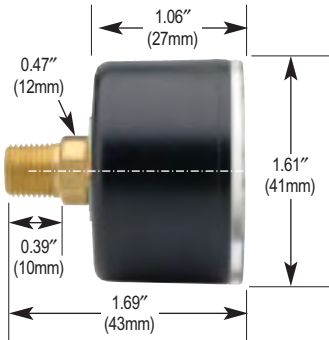

25-910

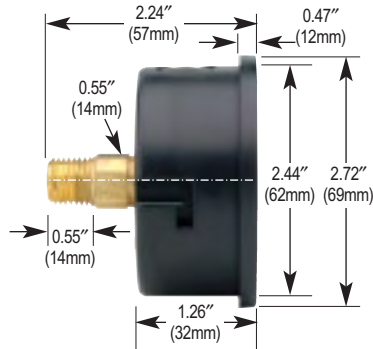

25-911

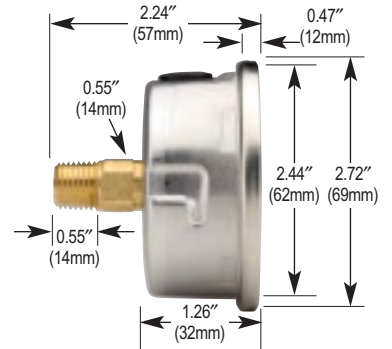

25-900 Front Flange

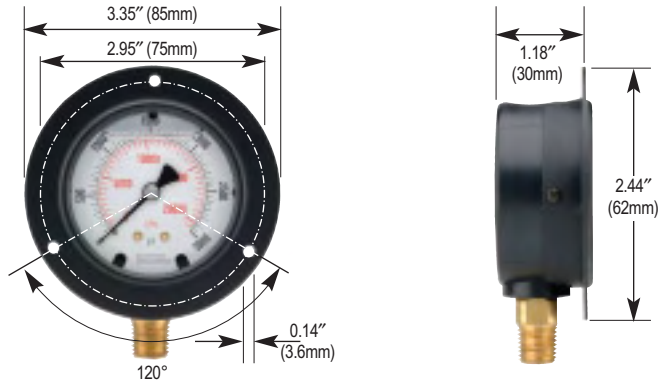

40-901 Front Flange

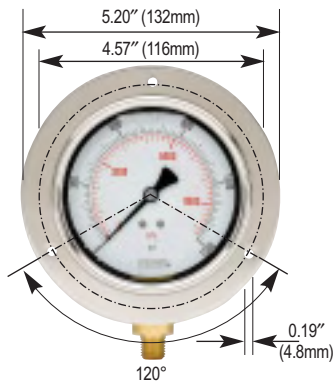

25-910 Front Flange

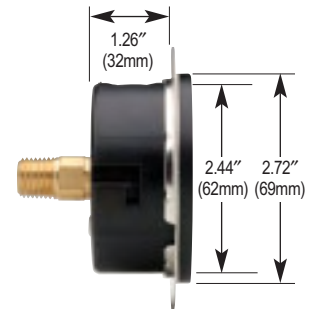
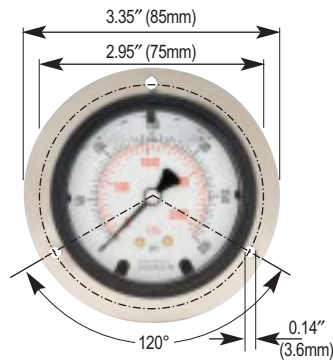

25-911 Front Flange

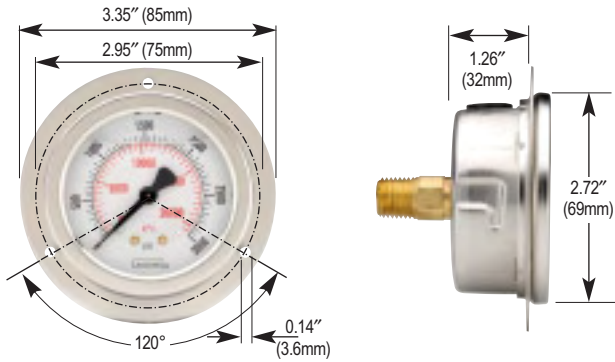

40-911 Front Flange

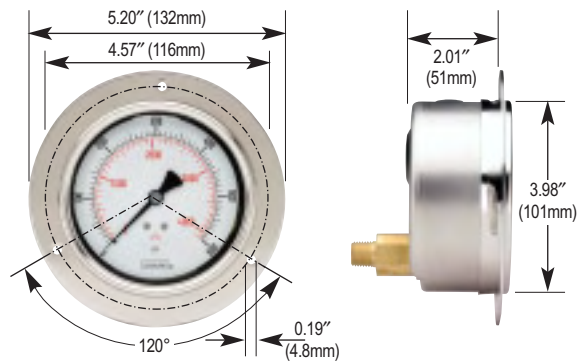

25-910 Flange Ring

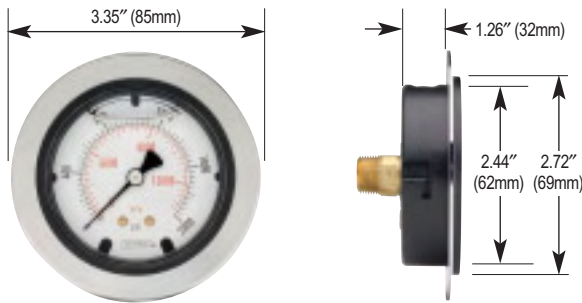

25-911 Flange Ring

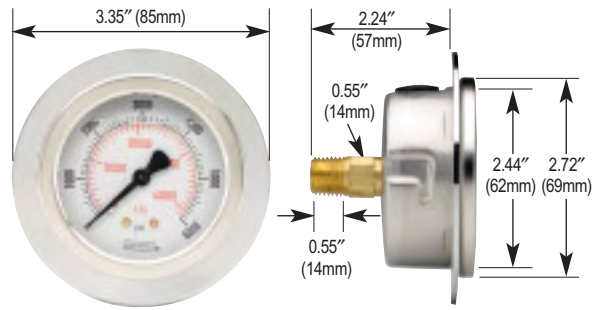

25-910 Panel Mount Clamp

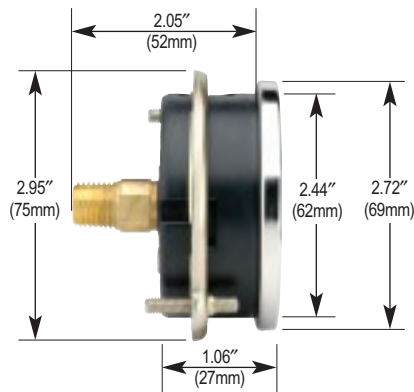

25-911 Panel Mount Clamp

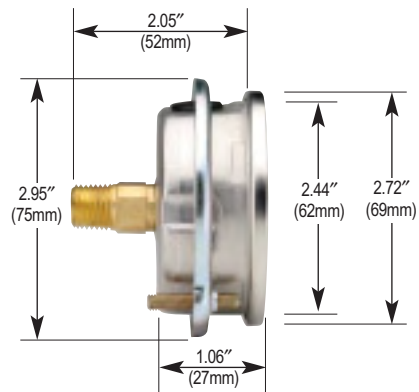

40-911

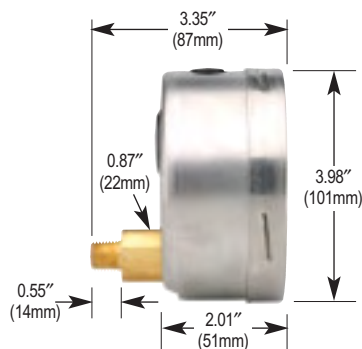



1000 SERIES

- Allows for local digital indication of pressure in place of mechanical gauges
- Integrated battery provides 4000 hours of battery life
- Pressure ranges from 30/30 psi to 10,000 psi
- 4 inch size – bottom connected
- Durable 304 Stainless steel case
- Display has an integrated bar graph with a trailing indicating pointer to show the trends in a working pressure system
- Additional 4-1/2 digit display provides a direct readout of the peak value, tare, min./max. memory, and other functions
- Optional internal light ensures display is optimally lit for a clear readout in all lighting conditions
- Buttons on the front of the display allow easy adjustment of the programmable functions
- Meets all electromagnetic compatibility requirements (EMC) to EN 61326
- CE compliant to suppress RFI, EMI and ESD
- Optional features: Tare function, password protection, internal lighting, 300° rotatable base, Rubber Case Protector

APPLICATIONS

- Machine construction
- Plant and apparatus construction
- Hydraulics
- Pneumatics
- Measuring equipment monitoring

SPECIFICATIONS

Display	0.43 " high liquid crystal display
Digits	4 STD. 4-1/2, up to 9999
Accuracy	±0.5 % Full Scale (BFSL)
Update Rate	5 times/second
Pressure Ranges	Standard ranges from 30 psig to 10000 psig, compound ranges from 30/30 psig to 30/600 psig
Proof Pressure	2 times Full Scale range, maximum 15000 psi
Wetted Materials	≤ 750 psig stainless steel, aluminum, NBR, ceramic measuring element ≥ 1000 psig stainless steel, thin-film measuring element
Housing Material	Stainless steel
Power Supply	2 x 1.5V "AA" Battery 4000 hrs ("AA" 2000 mAh)
Programmable Functions	Adjustable through front key pad Tare ±20% of Full Scale range On/Off Adjustable automatic turn off Measuring Unit bar, psi, MPa
Temperature Influence	Compensated 32 °F to 140 °F (0 °C to 60 °C) Effect ±0.15 % per 10K at zero and span Span effect is ±0.005 % Full Scale/°F
Temperature Ranges	Storage -4°F to 158°F (20°C to 70°C) Media -22°F to 185°F (-30°C to 85°C) Ambient 14°F to 140°F (-10°C to 60°C)
Environmental Rating	NEMA 4X (IP 65 according to EN60529/IEC529)
Electromagnetic Rating	Compliant to EN 61326, EMI and ESD protection
Weight	0.88 lbs.

ORDERING INFORMATION								
SERIES	1000							
PRESSURE RANGES	30/30	-30 inHg to 30 psig	30	0 psig to 30 psig	1450	0 psig to 1450 psig	7500	0 psig to 7500 psig
	30/60	-30 inHg to 60 psig	60	0 psig to 60 psig	2000	0 psig to 2000 psig	10000	0 psig to 10000 psig
	30/145	-30 inHg to 145 psig	145	0 psig to 145 psig	3000	0 psig to 3000 psig		
	30/300	-30 inHg to 300 psig	300	0 psig to 300 psig	5000	0 psig to 5000 psig		
	30/600	-30 inHg to 600 psig	600	0 psig to 600 psig	6000	0 psig to 6000 psig		
			psig = Gauge Pressure		Other ranges available on special request			
PROCESS CONNECTIONS	2 1/4" NPT							
OPTIONS	1	Peak memory - Standard	ORF	Threaded orifice				
	6	Enhanced Software	RCP	Rubber Case Protector				

Please consult your local NOSHOK Distributor or NOSHOK, Inc. for availability and delivery information.

EXAMPLE

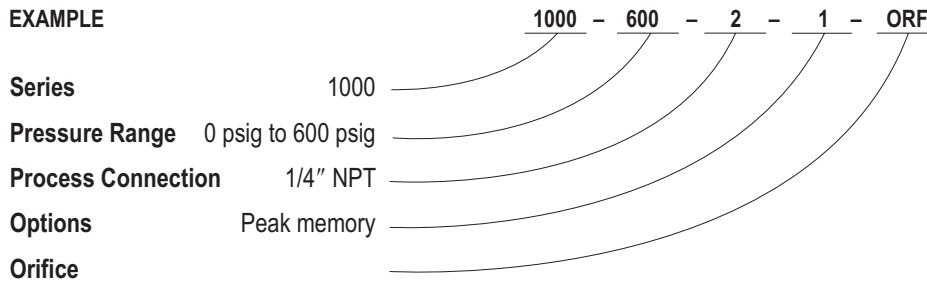

OUTLINE DIMENSIONS

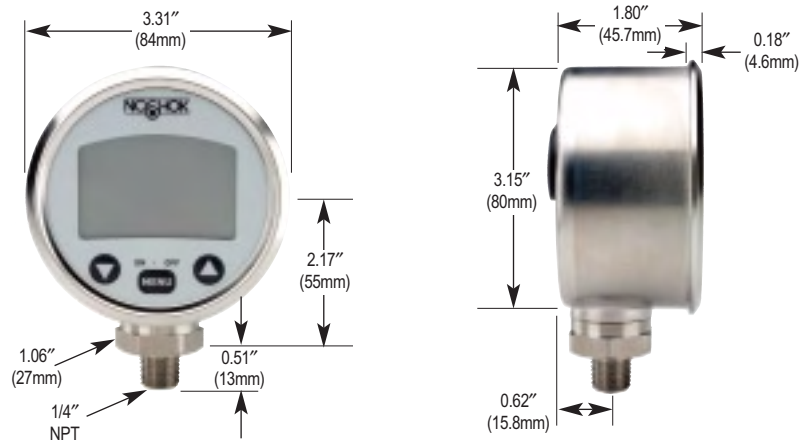

Differential Gauge - Piston Type



1000 SERIES

- Accurately measures the pressure drop across filters, pumps, strainers, separators and valves
- Maximum static or working pressure to 6,000 psi
- 2-1/2 and 4-1/2 inch sizes - back or side connected
- Rugged case construction with weather-resistant NEMA 4X enclosure
- Single piece construction of ceramic magnet/piston minimizes “blow by” and increases accuracy
- Optional liquid filling lubricates gauge internals and extends service life by dampening the effects of vibration, pulsation and shock
- Media leakage within the sensor body is by design and kept to a minimum through precise engineering specifications
- Shipped with a certificate of calibration to ensure accuracy and quality performance
- Cost effective

SPECIFICATIONS

Nominal Sizes	2-1/2 Inch (63.5mm) 4-1/2 Inch (114.3mm)
Case and Bezel Material	Fiberglass reinforced thermoplastic
Lens	Acrylic – Standard Laminated safety glass – optional
Sensor Housing Material	Black anodized aluminum – standard 316L Stainless steel – optional
Sensor Material	316 Stainless steel and ceramic piston/magnet
O-Ring Material	Viton – standard Buna N – optional Ethylene propylene – optional
Process Connection	1/4" NPT Female, back connection – standard 1/4" NPT Female, side connection – optional
Accuracy	±2% of Full Scale on rising pressure
Dial	Aluminum, white background with black markings
Pointer	Balanced aluminum, black finish
Gauge Fill Fluid	Glycerine – optional Others available – please consult factory
Operating Temp.	-40°F to 200°F (-40°C to 93°C)
Ranges	0 to 5 psid through 0 to 100 psid
Max. Working Static Pressure	6000 psig

APPLICATIONS

- Filters
- Flow indicators
- Heat exchangers
- Back flow restrictors
- Hydraulic and pneumatic systems
- Water treatment systems
- Pumps and compressors
- Industrial machinery and machine tools

ORDERING INFORMATION												
GAUGE SIZE & SERIES	25 - 10	2-1/2 Inch	45 - 10	4-1/2 Inch								
CONNECTION LOCATION	1	Back	2	Side								
CONNECTION SIZE	2	1/4" NPT Female										
PRESSURE RANGE	P5	0 to 5 psid	P15	0 to 15 psid	P25	0 to 25 psid	P50	0 to 50 psid	P75	0 to 75 psid	P100	0 to 100 psid
SENSOR HOUSING MATERIAL	A	Aluminum, black	S	316L Stainless steel								
O-RING MATERIAL	2	Viton	3	Buna N	4	Ethylene Propylene						
CASE MATERIAL	P	Thermoplastic										
LENS	1	Acrylic	2	Safety Glass	3	Acrylic with MIP	4	Acrylic with Alarm Contacts				
FILL FLUID	GY	Glycerine	SL	Silicone	HL	Halocarbon						

Please consult your local NOSHOK Distributor or NOSHOK, Inc. for availability and delivery information.

EXAMPLE

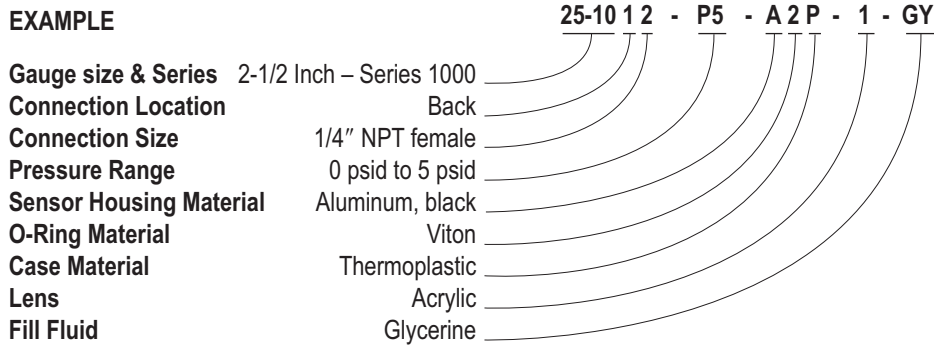

OUTLINE DIMENSIONS

PANEL CUT-OUT DIMENSIONS

2-1/2 Inch Gauge

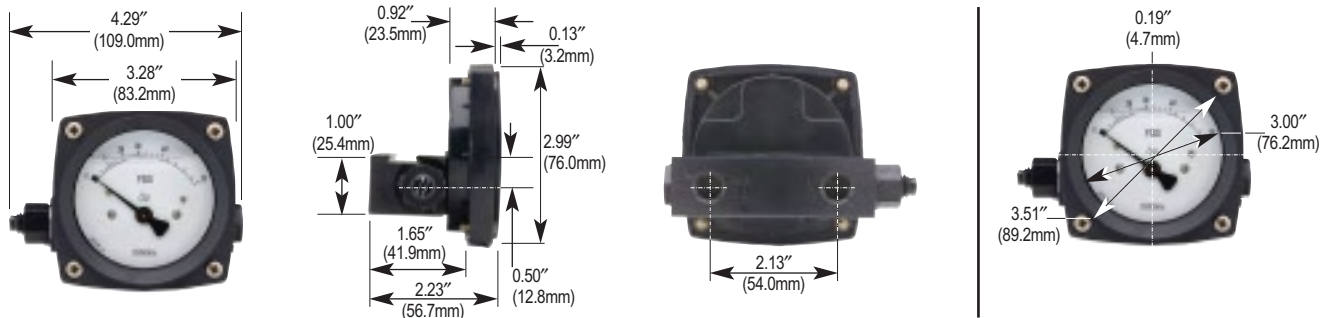

4-1/2 Inch Gauge

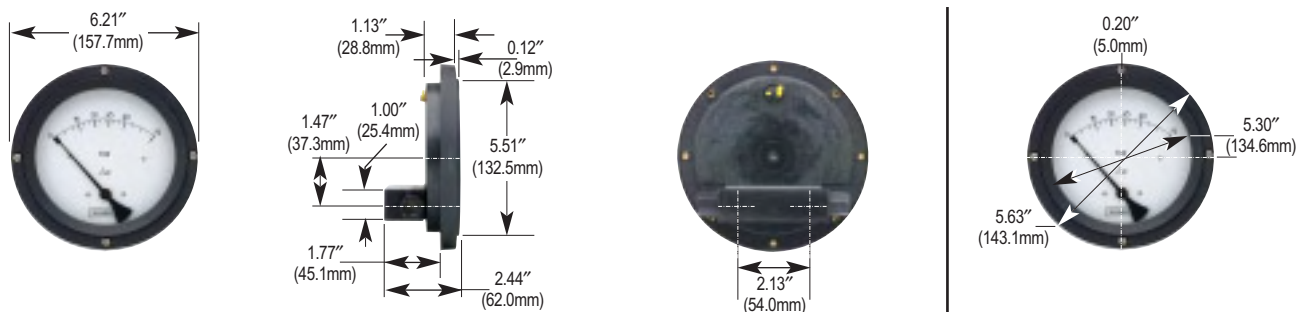

Differential Gauge - Diaphragm Type



1100 SERIES

- Precisely measures pressure drops across filters, strainers, separators, heat exchangers and applications where a higher level of solids are present in the measuring media
- High side is completely isolated from low side to prevent fluid movement between ports
- Maximum static or working pressure to 3,000 psi, 1,500 psi with brass housing
- 2-1/2 and 4-1/2 inch sizes – top & bottom, or back connected
- Sensor housing is cast in a black anodized aluminum, 316L Stainless steel or brass and comes standard with a weather-resistant NEMA 4X enclosure and shatter-resistant acrylic lens
- Optional liquid filling lubricates gauge internals and extends service life by dampening the effects of vibration, pulsation and shock
- Convoluted diaphragm fully supported to the rated working pressure of the gauge
- Shipped with a certificate of calibration to ensure accuracy and quality performance

SPECIFICATIONS

Nominal Sizes	2-1/2 Inch (63.5mm) 4-1/2 Inch (114.3mm)
Case and Bezel Material	Fiberglass reinforced thermoplastic
Lens	Acrylic – standard Laminated safety glass – optional
Sensor Housing Material	Black anodized aluminum – standard 316L Stainless steel – optional Brass - optional
Sensor Material	316 Stainless steel and ceramic magnet
O-Ring Material	Buna N – standard Viton – optional Ethylene propylene – optional
Process Connection	1/4" NPT Female, back connection – standard 1/4" NPT Female, top & bottom – optional
Accuracy	±2% Full Scale for ranges 0 psid to 15 psid & above ±5% Full Scale for ranges below 0 psid to 15 psid
Dial	Aluminum, white background with black markings.
Pointer	Balanced aluminum, black finish
Gauge Fill Fluid	Glycerine – optional Others available – please consult factory
Operating Temp.	-40°F to 200°F (-40°C to 93°C)
Ranges	0 to 50 inH ₂ O through 0 psid to 100 psid
Max. Working Static Pressure	3000 psig – 316L Stainless steel and aluminum housing 1500 psig – brass housing

APPLICATIONS

- Filters
- Flow indicators
- Heat exchangers
- Back flow restrictors
- Hydraulic and pneumatic systems
- Water treatment systems
- Pumps and compressors
- Industrial machinery and machine tools

ORDERING INFORMATION						
GAUGE SIZE & SERIES	25 - 11	2-1/2 Inch	45 - 11	4-1/2 Inch		
CONNECTION LOCATION	0	Top & bottom	1	Back		
CONNECTION SIZE	2	1/4" NPT female				
PRESSURE RANGE	W50	0 to 50 inH ₂ O	W300	0 to 300 inH ₂ O	P15	0 to 15 psid
	W75	0 to 75 inH ₂ O	W400	0 to 400 inH ₂ O	P25	0 to 25 psid
	W100	0 to 100 inH ₂ O	P5	0 to 5 psid	P30	0 to 30 psid
	W200	0 to 200 inH ₂ O	P10	0 to 10 psid	P50	0 to 50 psid
SENSOR HOUSING MATERIAL	A	Aluminum, black	B	Brass		
	S	316L Stainless steel				
O-RING MATERIAL	2	Viton	3	Buna N	4	Ethylene propylene
CASE MATERIAL	P	Thermoplastic				
LENS	1	Acrylic	2	Safety Glass	3	Acrylic with MIP
FILL FLUID (optional)	GY	Glycerine	SL	Silicone	HL	Halocarbon

Please consult your local NOSHOK Distributor or NOSHOK, Inc. for availability and delivery information.

EXAMPLE

Gauge Size & Series 2-1/2 Inch – Series 1100
Connection Location Back
Connection Size 1/4" NPT female
Pressure Range 0 psid to 75 psid
Sensor Housing Material Aluminum, black
O-Ring Material Viton
Case Material Thermoplastic
Lens Acrylic
Fill Fluid (optional) Glycerine

25-11 1 2 - P75 - A 2 P - 1 - GY

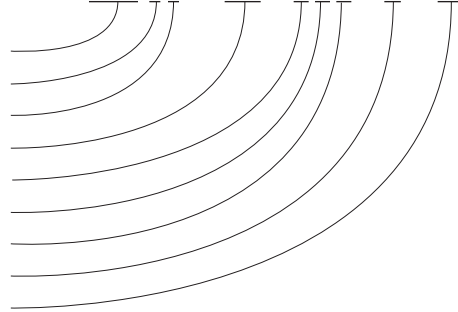

OUTLINE DIMENSIONS

PANEL CUT-OUT DIMENSIONS

2-1/2 Inch Gauge

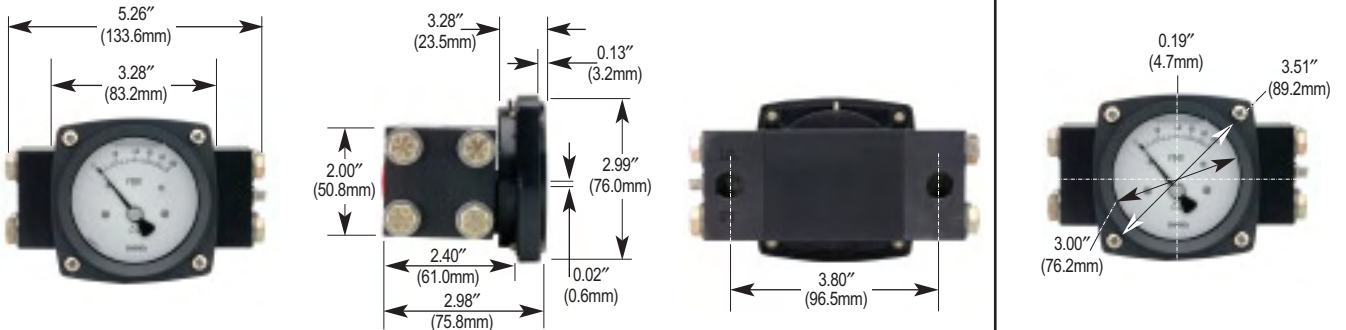

4-1/2 Inch Gauge

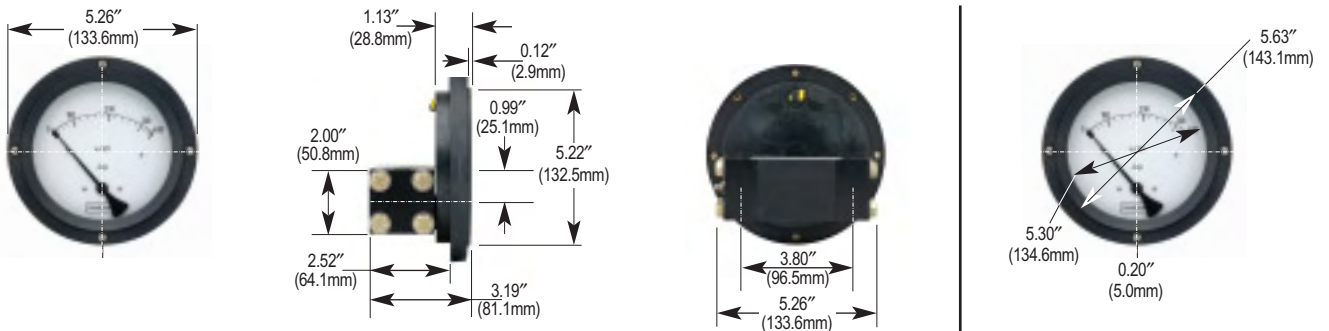

Differential Gauge - Membrane Type High Static Pressure



1200 SERIES

- Designed for applications requiring high static pressure & high differential pressure measurement
- Maximum static or working pressure to 3,000 psi
- Full scale accuracy of $\pm 1\%$ on rising pressure – zero adjustment standard
- 4-1/2 and 6 inch sizes – top & bottom, or back connected
- Durable case construction with weather-resistant NEMA 4X rating & shatter-resistant acrylic lens
- A bi-directional overpressure valve protects the sensor membrane from damage
- Monel membranes and 316L Stainless steel wetted parts
- Optional liquid filling lubricates gauge internals and extends service life by dampening the effects of vibration, pulsation and shock
- Shipped with a certificate of calibration to ensure accuracy and quality performance

APPLICATIONS

- Filters
- Flow indicators
- Heat exchangers
- Back flow indicators
- Hydraulic and pneumatic systems
- Water treatment systems
- Pumps and compressors
- Cryogenic gases and corrosive media

SPECIFICATIONS

Nominal Sizes	4-1/2 Inch (114.3mm) 6 Inch (152mm)
Dial Case Material	Black anodized aluminum – standard 316L Stainless steel – optional
Bezel Material	316L Stainless steel
Lens	Acrylic – standard Laminated safety glass – optional
Sensor Housing	316L Stainless steel
Membrane Fill	Halocarbon
Sensor Element	Monel 500 – standard
O-Ring Material	PTFE
Process Connection	1/4" NPT Female, back connection – standard 1/4" NPT Female, dual top & bottom – optional
Movement	Stainless steel
Accuracy	$\pm 1\%$ of Full Scale or rising pressure
Dial	Aluminum, white background with black markings – standard Aluminum, black background with white markings – optional
Pointer	Balanced aluminum, black finish
Gauge Fill Fluid	Glycerine – optional Others available – please consult factory
Operating Temp.	-40°F to 200°F (-40°C to 93°C)
Ranges	0 to 100 inH ₂ O through 0 to 600 psid
Max. Working Static Pressure	3000 psig

ORDERING INFORMATION					
GAUGE SIZE & SERIES	45 - 12	4-1/2 Inch	60 - 12	6 Inch	
CONNECTION LOCATION	0 Top & bottom 1 Back				
CONNECTION SIZE	2 1/4" NPT female				
PRESSURE RANGE	W100 0 to 100 inH ₂ O W150 0 to 150 inH ₂ O W200 0 to 200 inH ₂ O W300 0 to 300 inH ₂ O	W400 0 to 400 inH ₂ O P15 0 to 15 psid P30 0 to 30 psid P60 0 to 60 psid	P100 0 to 100 psid P230 0 to 230 psid P300 0 to 300 psid P400 0 to 400 psid	P500 0 to 500 psid P600 0 to 600 psid	
SENSOR HOUSING MATERIAL	S 316L Stainless steel				
O-RING MATERIAL	1 PTFE				
CASE MATERIAL	A Aluminum, black		S 316L Stainless steel		
LENS	1 Acrylic		2 Safety glass		
FILL FLUID (optional)	GY Glycerine	SL Silicone	HL Halocarbon		

Please consult your local NOSHOK Distributor or NOSHOK, Inc. for availability and delivery information.

EXAMPLE

- Gauge Size & Series** 6 Inch—Series 1200
- Connection Location** Top & Bottom
- Connection Size** 1/4" NPT female
- Pressure Range** 0 psid to 15 psid
- Sensor Housing Material** 316L Stainless steel
- O-Ring Material** PTFE
- Case Material** Aluminum, black
- Lens** Safety glass
- Fill Fluid (optional)** Glycerine

60-12 0 2 - P15 - S 1 A - 2 - GY

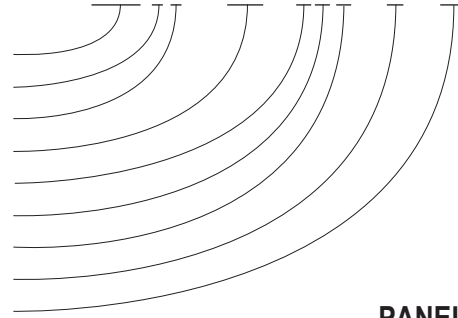

OUTLINE DIMENSIONS

PANEL CUT-OUT DIMENSIONS

4-1/2 Inch Gauge

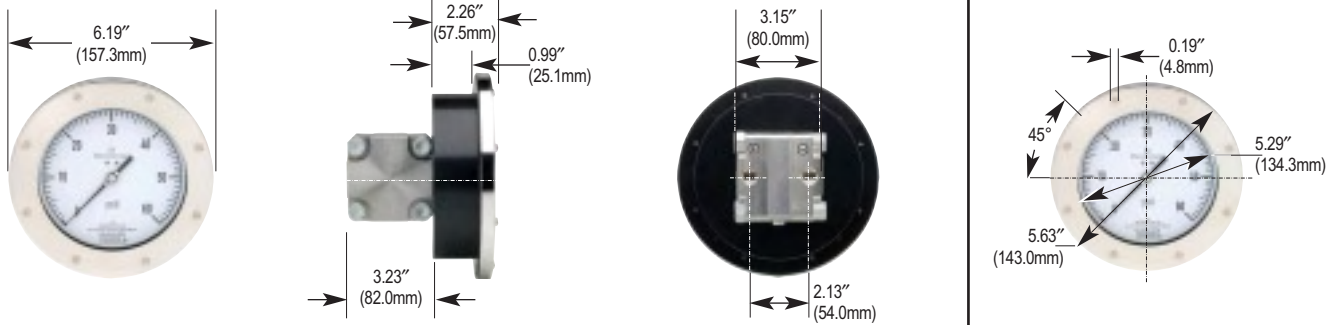

6 Inch Gauge

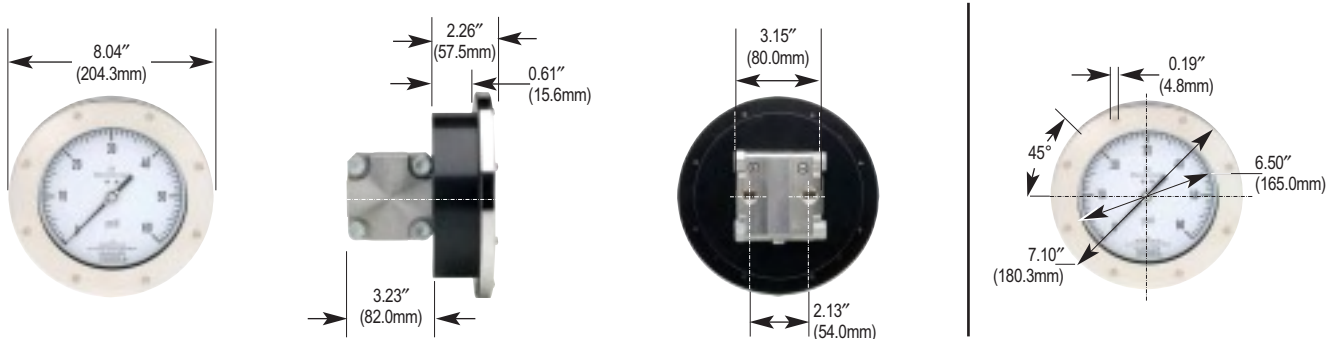

Differential Gauge - Membrane Type Nominal Static Pressure



1300 SERIES

- Designed for integral process applications requiring nominal static and low differential pressure measurement
- Maximum static or working pressure to 600 psi
- Full scale accuracy of $\pm 1\%$, on rising pressure - zero adjustment standard
- 4-1/2 and 6 inch sizes – top & bottom, or back connected
- Durable case construction with weather-resistant NEMA 4X rating & shatter-resistant acrylic lens
- A bi-directional overpressure valve protects the sensor membrane from damage
- 316L Stainless steel wetted parts
- Optional liquid filling lubricates gauge internals and extends service life by dampening the effects of vibration, pulsation and shock
- Shipped with a certificate of calibration to ensure accuracy and quality performance

SPECIFICATIONS

Nominal Sizes	4-1/2 Inch (114.3mm) 6 Inch (152mm)
Dial Case Material	Black anodized aluminum – standard 316L Stainless steel – optional
Bezel Material	316L Stainless steel
Lens	Acrylic – standard Laminated safety glass – optional
Sensor Housing	316L Stainless steel
Membrane Fill	Halocarbon
Sensor Element	316L Stainless steel (NACE compliant)
O-Ring Material	PTFE, Viton or Buna N – optional
Process Connection	1/4" NPT Female, dual top & bottom – standard 1/4" NPT Female, back connection – optional
Movement	Stainless steel
Accuracy	$\pm 1\%$ of Full Scale on rising pressure
Dial	Aluminum, black background with white markings – standard Aluminum, white background with black markings – optional
Pointer	Balanced aluminum, black finish
Gauge Fill Fluid	Glycerine – optional Others available – please consult factory
Operating Temp.	-40°F to 200°F (-40°C to 93°C)
Ranges	0 to 100 inH ₂ O through 0 to 400 psid
Max. Working Static Pressure	600 psig

APPLICATIONS

- Settings which include caustic liquid or gaseous media and/or low temperature gases
- Filters
- Flow indicators
- Heat exchangers
- Back flow indicators
- Hydraulic and pneumatic systems
- Water treatment systems
- Pumps and compressors
- Cryogenic gases and corrosive media

ORDERING INFORMATION						
GAUGE SIZE & SERIES	45 - 13	4-1/2 Inch	60 - 13	6 Inch		
CONNECTION LOCATION	0	Top & bottom	1	Back		
CONNECTION SIZE	2	1/4" NPT female				
PRESSURE RANGE	W100	0 to 100 inH ₂ O	W400	0 to 400 inH ₂ O	P100	0 to 100 psid
	W150	0 to 150 inH ₂ O	P15	0 to 15 psid	P230	0 to 230 psid
	W200	0 to 200 inH ₂ O	P30	0 to 30 psid	P300	0 to 300 psid
	W300	0 to 300 inH ₂ O	P60	0 to 60 psid	P400	0 to 400 psid
SENSOR HOUSING MATERIAL	S	316L Stainless steel				
O-RING MATERIAL	1	PTFE				
CASE MATERIAL	A	Aluminum, black	S	316L Stainless steel		
LENS	1	Acrylic	2	Safety glass		
FILL FLUID (optional)	GY	Glycerine	SL	Silicone	HL	Halocarbon

Please consult your local NOSHOK Distributor or NOSHOK, Inc. for availability and delivery information.

EXAMPLE

- Gauge Size & Series** 4-1/2 Inch-Series 1300
- Connection Location** Top & Bottom
- Connection Size** 1/4" NPT female
- Pressure Range** 0 to 100 inH₂O
- Sensor Housing Material** 316L Stainless steel
- O-Ring Material** PTFE
- Case Material** Aluminum, black
- Lens** Safety glass
- Fill Fluid (optional)** Glycerine

45-13 0 2 - W100 - S 1 A - 2 - GY

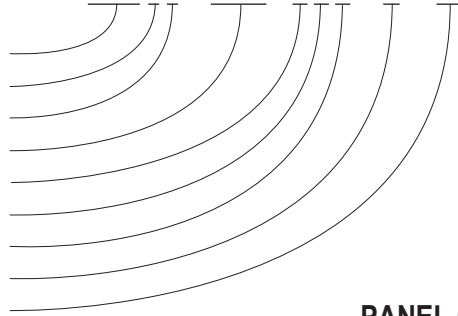

OUTLINE DIMENSIONS

PANEL CUT-OUT DIMENSIONS

4-1/2 Inch Gauge

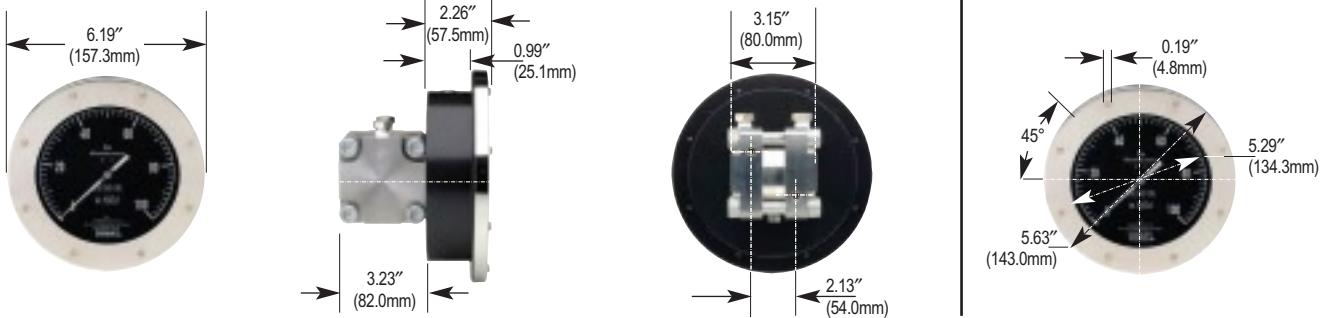

6 Inch Gauge

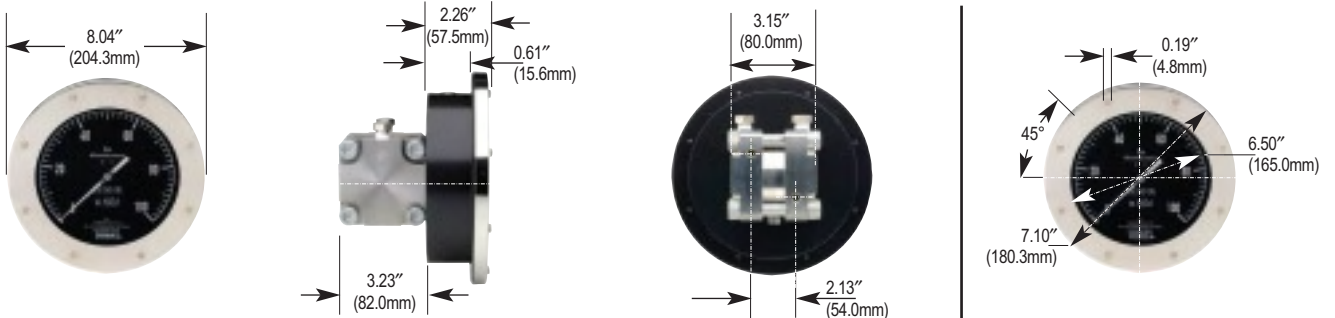

Differential Pressure Gauges

Dial Configuration Drawings

1000 Series 2-1/2"

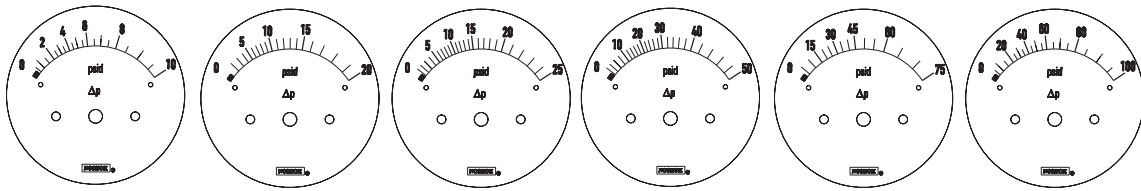

1000 Series 4-1/2"

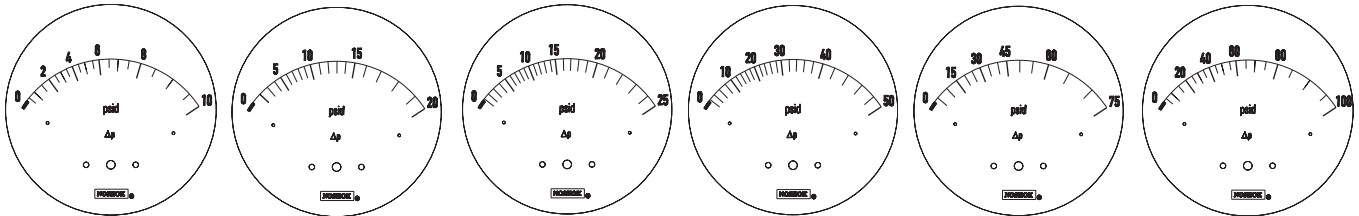

1100 Series 2-1/2"

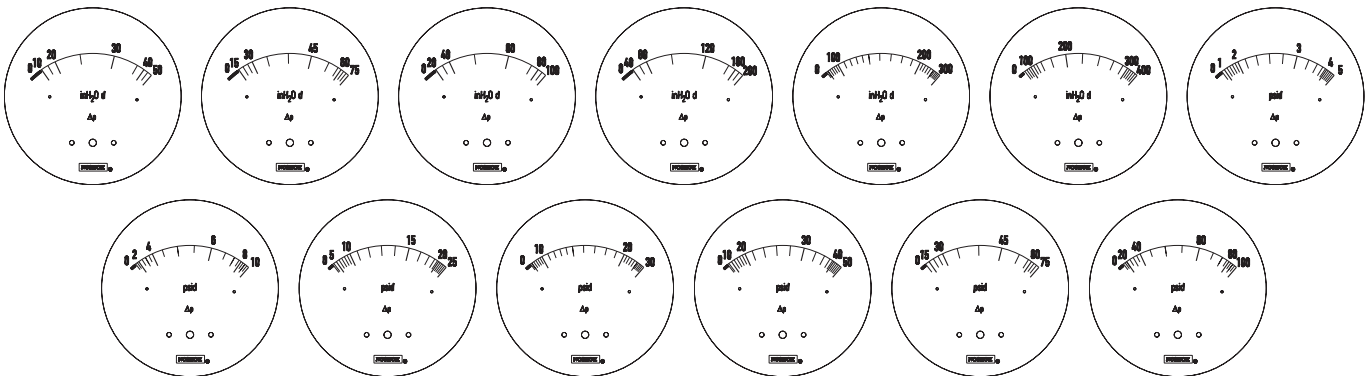

1100 Series 4-1/2"

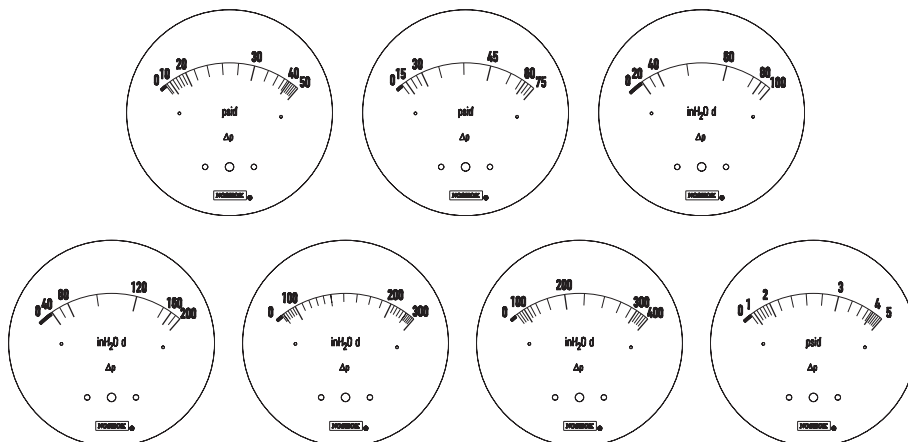

1100 Series 4-1/2"

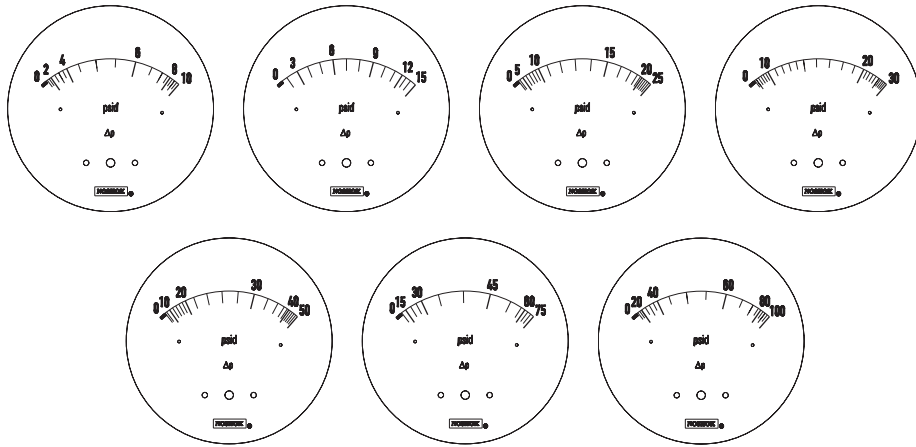

1200 Series 4-1/2"

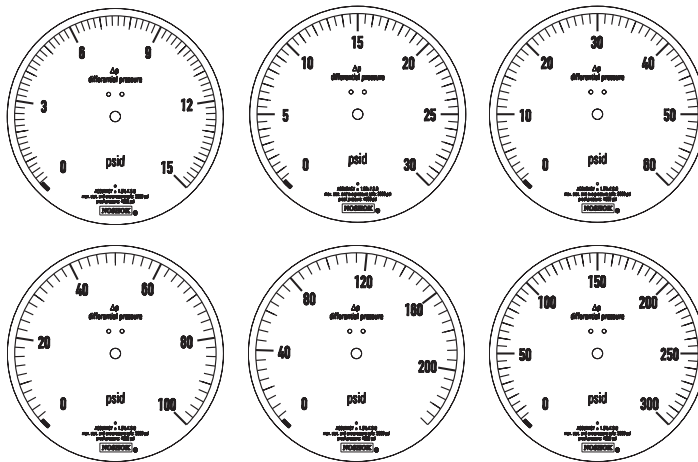

1300 Series 4-1/2"

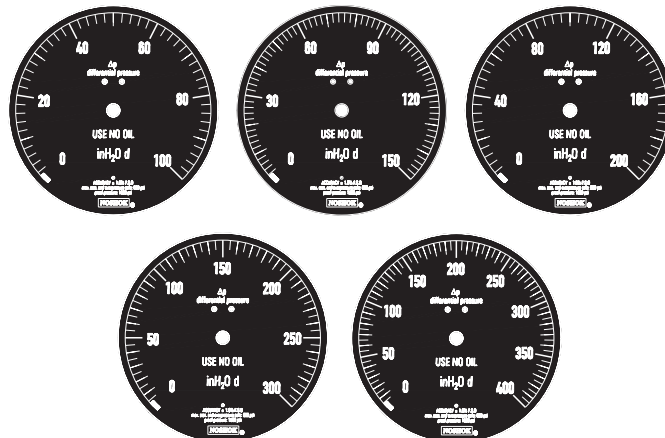



10 SERIES

- Meets current standards for 3A and ASME BPE-2009
- Compact size for space restricted applications
- Wide variety of ranges from vacuum to 600 psi
- Process temperatures up to 300°F (150°C)
- Gauge size 2 inch, Clamp size 3/4 inch
- Case and cover ring are electropolished Stainless steel for exceptional corrosion resistance, complemented with a polycarbonate lens
- Tri-Clamp® housing and diaphragm are constructed from 316L Stainless steel with wetted surfaces electropolished to Ra25 or better
- 316L Stainless steel socket is welded to the Tri-Clamp® process connection for greater strength and durability
- C.I.P, S.I.P and Autoclave* for the demanding needs of the sanitary market

*Only dry case gauges are recommended for Autoclave

APPLICATIONS

- Food & beverage
- Dairy
- Pharmaceutical
- Biomedical

SPECIFICATIONS

Case	2" Electropolished 304 Stainless steel
Cover Ring	Electropolished 304 Stainless steel
Lens	Polycarbonate
Bourdon Tube	316 Stainless steel
Socket	316L Stainless steel welded to process connection
Movement	Stainless steel
Accuracy	±2.5% Full Scale, ANSI grade B
Pointer	Aluminum, black finish
Dial	Aluminum, white background, black print
Process Connection	3/4" Tri-Clamp® sanitary seal
Seal Housing Material	316L Stainless steel
Diaphragm Material	316L Stainless steel, electropolished to Ra25 or better
Fill Fluid	Glycerine, USP grade
Media Temperature	-40°F to 300°F (-40°C to 150°C)

*Note: Autoclave requires the addition of optional laminated safety glass lens

Diaphragm seal must be installed facing downward or in a vertical position for drainability. Do not install diaphragm seal facing in an upward position.

ORDERING INFORMATION						
SERIES	100	Series 10 fractional				
CLAMP SIZE	06	3/4 Inch				
SEAL FILL FLUID	1	Glycerine	Other Food Grade Quality Fill Fluids Available – Please Consult Factory			
GAUGE SIZE	20	2 Inch				
PRESSURE RANGE	40	0 psig to 15 psig	49	0 psig to 100 psig	61	0 psig to 300 psig
	43	0 psig to 30 psig	55	0 psig to 160 psig	64	0 psig to 400 psig
	46	0 psig to 60 psig	58	0 psig to 200 psig	70	0 psig to 600 psig
OPTION	3	Safety glass lens	Required for autoclave applications			

Please consult your local NOSHOK Distributor or NOSHOK, Inc. for availability and delivery information.

EXAMPLE

- Series**
- Clamp Size**
- Seal Fill Fluid**
- Gauge Size**
- Pressure Range**
- Option**

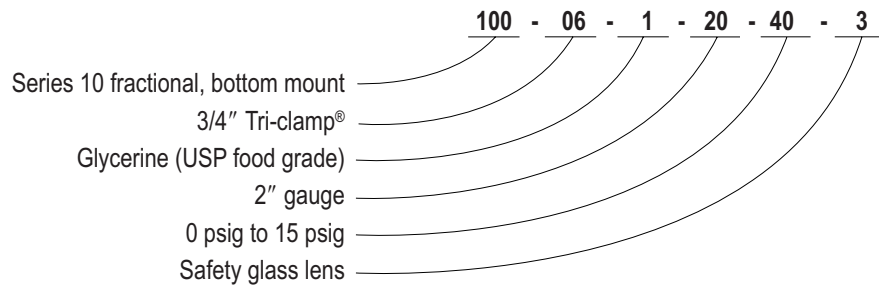

OUTLINE DIMENSIONS

2" Gauge with 3/4" Tri-Clamp® Connection

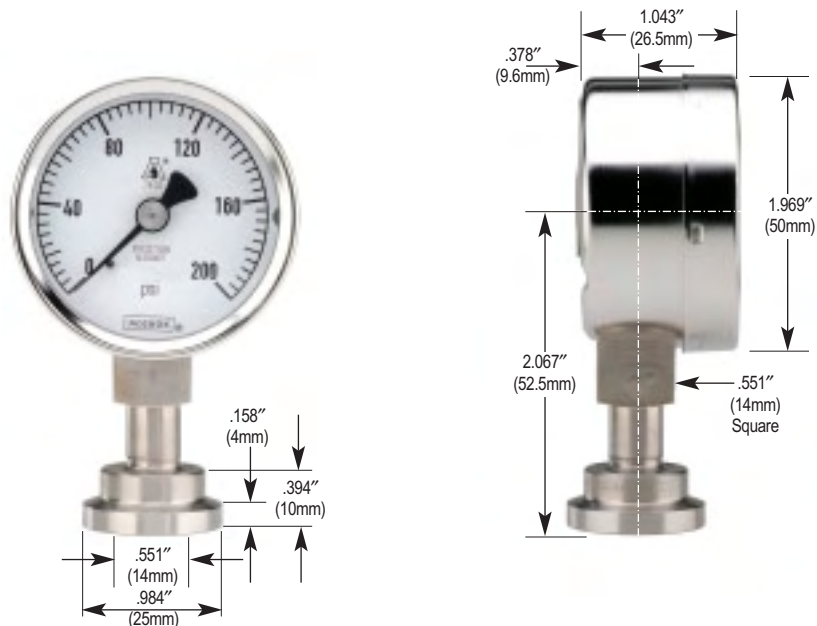



10 SERIES

- Meets current standards for 3A and ASME BPE-2009
- Ranges from -30 inHg to 0 psi through -30 inHg to 600 psi
- 2-1/2 and 4 inch sizes available, with 1-1/2 or 2 inch Tri-Clamp® process connections
- Electropolished 304 Stainless steel case with welded 316LSS socket and Tri-Clamp® process connection
- 316L Stainless steel wetted materials electropolished to Ra25 or better for outstanding performance
- Optional liquid filling lubricates gauge internals and extends service life by dampening the effects of vibration, pulsation and shock
- Optional Maximum Indicating Pointer or Adjustable Pointer
- Exceptional corrosion resistance
- C.I.P, S.I.P and Autoclave* for the demanding needs of the sanitary market

*Only dry case gauges are recommended for Autoclave

APPLICATIONS

- Food & beverage
- Dairy
- Pharmaceutical

SPECIFICATIONS

Case	Electropolished 304 Stainless steel
Bayonet Ring	Electropolished 304 Stainless steel
Lens	Laminated safety glass
Bourdon Tube	316 Stainless steel "C" tube
Socket	316L Stainless steel, welded to case & process connection
Movement	Stainless steel
Accuracy	2-1/2" gauge ±1.5% Full Scale, ANSI grade A 4" gauge ±1.0% Full Scale, ANSI grade 1A
Pointer	Balanced aluminum, black finish
Dial	Aluminum, white background, black print
Gauge Fill Fluid	Glycerine, USP grade (optional)
Process Connection	1-1/2" or 2" Tri-clamp® sanitary seal
Seal Housing Material	316L Stainless steel
Diaphragm Material	316L Stainless steel, electropolished to Ra25 or better
Fill Fluid	Glycerine, USP grade
Media Temperature	-40°F to 300°F (-40°C to 150°C)

Diaphragm seal must be installed facing downward or in a vertical position for drainability. Do not install diaphragm seal facing in an upward position.

ORDERING INFORMATION				
SERIES	100 Series 10 heavy duty			
CLAMP SIZE	12 1-1/2 Inch	16 2 Inch		
SEAL FILL FLUID	1 Glycerine	Other Food Grade Quality Fill Fluids Available – Please Consult Factory		
GAUGE SIZE	25 2-1/2 Inch	40 4 Inch		
PRESSURE RANGE	01 -30 inHg to 0 psig*	13 -30 inHg to 100 psig	40 0 psig to 15 psig*	55 0 psig to 160 psig
	04 -30 inHg to 15 psig	16 -30 inHg to 160 psig	43 0 psig to 30 psig	58 0 psig to 200 psig
	07 -30 inHg to 30 psig	19 -30 inHg to 200 psig	46 0 psig to 60 psig	61 0 psig to 300 psig
	10 -30 inHg to 60 psig	22 -30 inHg to 300 psig	49 0 psig to 100 psig	64 0 psig to 400 psig
		70 0 psig to 600 psig		
GAUGE FILL	0 None	1 Glycerine (All Food Grade Quality Fill Fluids)	2 Silicone	3 Mineral oil
GAUGE OPTIONS	0 None	1 Max. indicating pointer	2 Adjustable pointer	

* Not available on 4" gauge and 1-1/2" Tri-Clamp®

Please consult your local NOSHOK Distributor or NOSHOK, Inc. for availability and delivery information.

EXAMPLE

Series Series 10 sanitary gauge, bottom mount
Clamp Size 1-1/2" Tri-clamp®
Seal Fill Fluid Glycerine (USP food grade)
Gauge Size 2-1/2" gauge
Pressure Range 0 psig to 160 psig
Gauge Fill Glycerine
Option Maximum indicating pointer

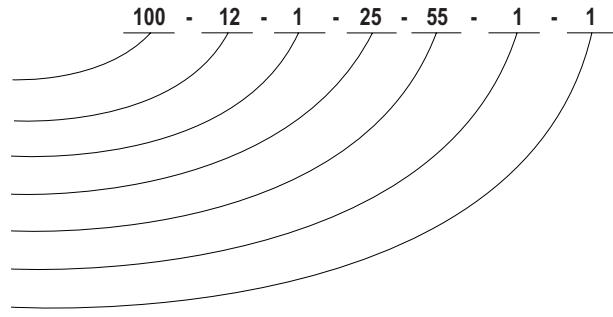

OUTLINE DIMENSIONS

4" Gauge with 2" Tri-Clamp® Connection

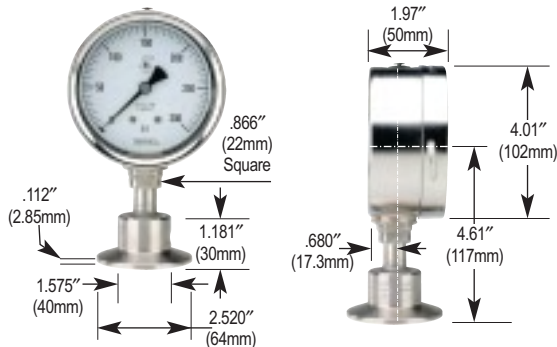

4" Gauge with 1-1/2" Tri-Clamp® Connection

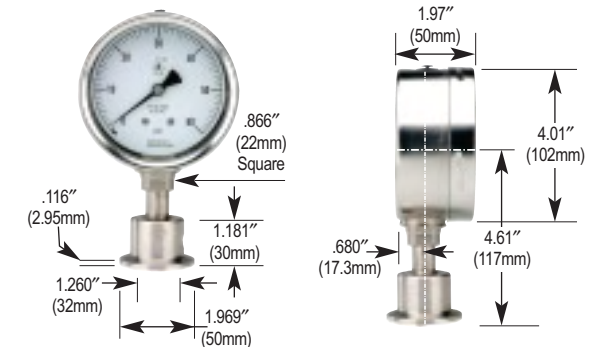

2-1/2" Gauge with 2" Tri-Clamp® Connection

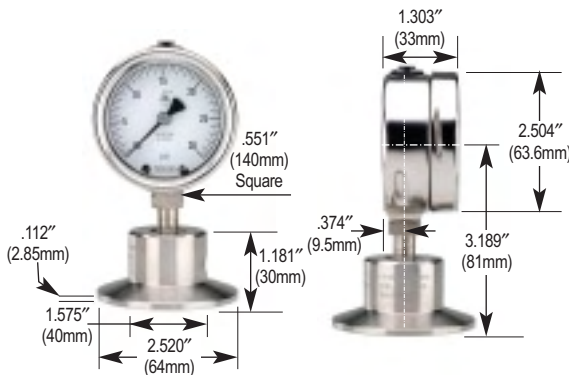

2-1/2" Gauge with 1-1/2" Tri-Clamp® Connection

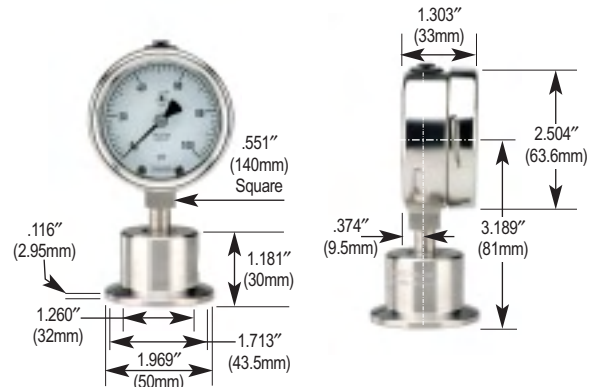



20 SERIES

- Meets current standards for 3A and ASME BPE-2009
- Ranges from 1,000 psi to 15,000 psi
- Process temperatures up to 300°F for use in more applications
- 4 inch size with 1-1/8 inch flanged process connection
- Electropolished 304 Stainless steel case with welded 316L Stainless steel socket and process connection for greater performance in high pressure applications
- 316L Stainless steel wetted materials electropolished to Ra25 or better
- Scratch-resistant laminated safety glass provides clear viewing without discoloring
- Optional liquid filling lubricates gauge internals and extends service life by dampening the effects of vibration, pulsation and shock
- C.I.P, S.I.P and Autoclave* for the demanding needs of the sanitary market

*Only dry case gauges are recommended for Autoclave

APPLICATIONS

- High pressure applications in:
 - Dairy
 - Food
 - Chemical
 - Biotechnology
 - Pharmaceutical

SPECIFICATIONS

Case	Electropolished 304 Stainless steel
Bayonet Ring	Electropolished 304 Stainless steel
Lens	Laminated safety glass
Bourdon Tube	316 Stainless steel coiled safety tube
Socket	316L Stainless steel, welded to case & process connection
Movement	Stainless steel
Accuracy	±1.0% Full Scale, ANSI grade 1A
Pointer	Balanced aluminum, black finish
Dial	Aluminum, white background, black print
Gauge Fill Fluid	Glycerine, USP grade
Mounting	Flange mounted
Process Connection	1-1/8" Homogenizer flange
Seal Housing Material	316L Stainless steel
Diaphragm Material	316L Stainless steel, electropolished to Ra25 or better
Fill Fluid	Glycerine, USP grade
Media Temperature	-40°F to 300°F (-40°C to 150°C)

Diaphragm seal must be installed facing downward or in a vertical position for drainability. Do not install diaphragm seal facing in an upward position.

ORDERING INFORMATION								
SERIES	200	Series 20 homogenizer						
CLAMP SIZE	42	1-1/8 Inch flange						
SEAL FILL FLUID	1	Glycerine	Other Food Grade Quality Fill Fluids Available– Please Consult Factory					
GAUGE SIZE	40	4 Inch						
PRESSURE RANGE	73	0 psig to 1000 psig	79	0 psig to 2000 psig	85	0 psig to 5000 psig	91	0 psig to 10000 psig
	76	0 psig to 1500 psig	82	0 psig to 3000 psig	88	0 psig to 6000 psig	94	0 psig to 15000 psig
GAUGE FILL	0	None	1	Glycerine	2	Silicone	3	Mineral oil
			(All Food Grade Quality Fill Fluids)					
GAUGE OPTIONS	0	None	1	Max. indicating pointer	2	Adjustable pointer		

Please consult your local NOSHOK Distributor or NOSHOK, Inc. for availability and delivery information.

EXAMPLE

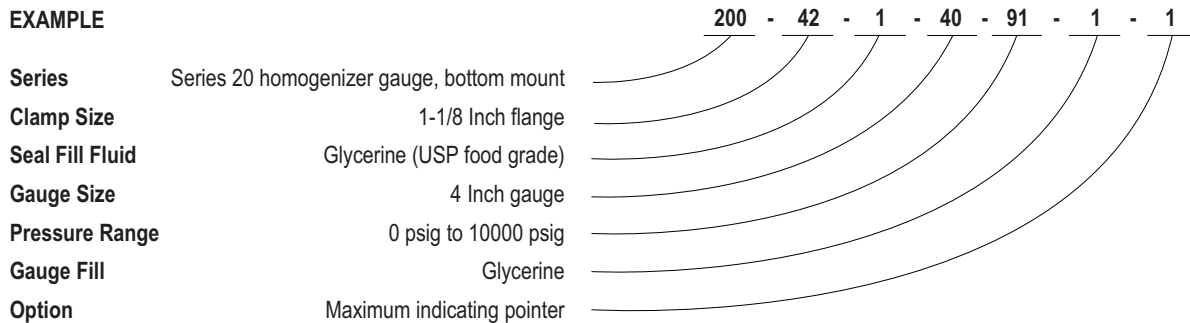

OUTLINE DIMENSIONS

4" Gauge with 1-1/8" Homogenizer Flange

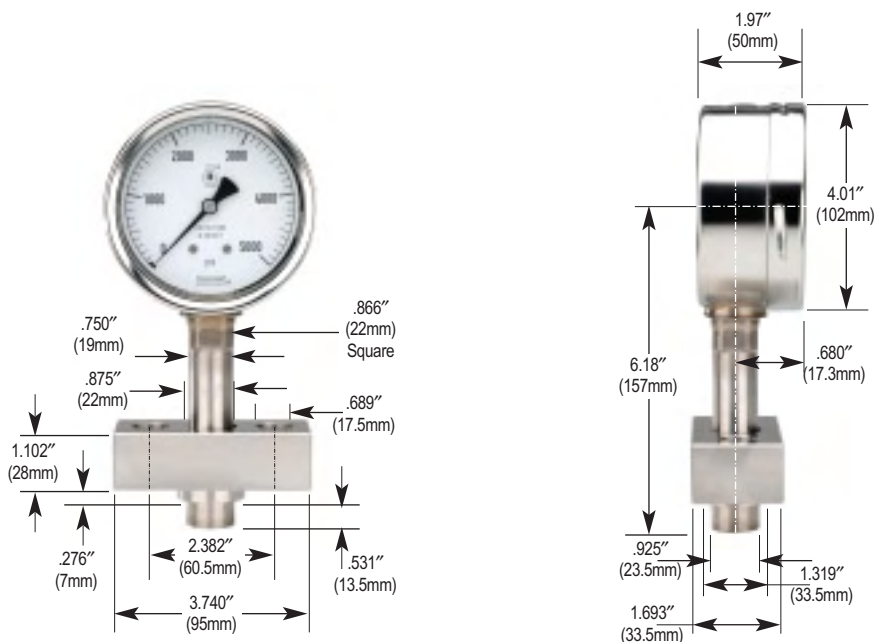

(Custom Flange Dimensions are Available to your Specifications – Please Consult Factory)

Diaphragm Seals



TYPE 10, 10H & 10H1

- Designed to isolate the pressure measuring instrument from high temperatures, or corrosive or viscous process media
- Maximum pressure rating is 2,000 psi
- Utilizes a replaceable diaphragm clamped between the flanged metal housings with an o-ring seal to create a leak-free union
- Process connection sizes from 1/4 inch NPT through 1-1/2 inch NPT
- Flushing port connection is an available option that allows the wetted areas of the seal to be cleaned, or the process vented without removing the unit from the line
- Consider gauge size, pressure range, media composition, ambient and operating temperature, and maximum working pressure when selecting
- For process temperatures over 212° F a capillary or cooling element is recommended, contact factory to order
- Fill fluid must be compatible with process media; i.e. Glycerine may become volatile in conjunction with a strong oxidizing agent such as chlorine, forms of oxygen or peroxide and nitric acids

PRODUCT SPECIFICATIONS	
Suitable Pressure Gauge Sizes	2-1/2, 4, 4-1/2 and 6 Inch Will also operate with most transducers, transmitters and pressure switches
Minimum Working Pressure	10: 0 psig to 30 psig through -30 inHg to 2,000 psig 10H, 10H1: 0 psig to 30 psig through 0 psig to 10,000 psig
Maximum Working Pressure	10: 2,000 psig @ 100 °F 10H, 10H1: 5,000 psig, 10,000 psig, @ 100 °F
Operating Temperature	-30°F – 350°F based upon material of construction and fill fluid

Fill Fluid Temperature Table

Fill Fluid	Temperature Range (°F)
Glycerine*	30 - 300
Silicone 200-10	-35 - 450
Silicone 704	30 - 520
Silicone 710	30 - 650
Silicone 550	-40 - 600
Silicone 510	-60 - 400
Fluorolube FS-5	-40 - 500
Silicone 200-350	0 - 300
Halocarbon Oil 6.3	-40 - 400
Ethylene Glycol	-30 - 300
Propylene Glycol	-50 - 200
Syltherm 800	-40 - 450
Mineral Oil	Note 1
Neobee M-20	-40 - 320

*Not recommended for use on vacuum applications
Note 1. To be advised

TYPE 10, 10H & 10H1

ORDERING INFORMATION DIMENSIONS

ORDERING INFORMATION						
TYPE	10	2,000 psi	10H	5,000 psi	10H1	10,000 psi
INSTRUMENT CONNECTION SIZES	02	1/4 inch NPT	04	1/2 inch NPT		
UPPER HOUSING MATERIAL	C	Carbon Steel	S	316 Stainless Steel		
DIAPHRAGM MATERIAL	A	Tantalum	M	Monel 400	S	316 Stainless Steel
	H	Hastelloy C – 276	N	Inconel 600	T	Teflon ^{®2}
O-RING MATERIAL	B	Buna N	T	Teflon ^{®2}	V	Viton [®]
PROCESS CONNECTION SIZES	02	1/4 Inch NPT	06	3/4 Inch NPT	10	1-1/4 Inch NPT
	04	1/2 Inch NPT	08	1 Inch NPT	12	1-1/2 Inch NPT
	(ASME and DIN Flanges Available Upon Request)					
LOWER HOUSING MATERIAL	C	Carbon Steel	M	Monel 400	S	316 Stainless Steel
	H	Hastelloy C-276	N	Inconel 600	U	Titanium ²
FLUSHING CONNECTION¹	1F	1/8 Inch NPT	2F	1/4 Inch NPT		

1) Not available on 10,000 psi model. 2) Not available on 10H or 10H1

NOTE: For process temperatures over 212°F, a capillary or cooling element is recommended. Contact NOSHOK factory to order.

EXAMPLE

Model Selection	Type 10	10
Instrument Connection Size	1/4 Inch NPT	02
Upper Housing Material	316 Stainless Steel	S
Diaphragm Material	316 Stainless Steel	S
O-ring Material	Buna N	B
Process Connection Size	1/2 Inch NPT	04
Lower Housing Material	316 Stainless Steel	S
Flushing Connection	(Optional)	1F

OUTLINE DIMENSIONS

Type 10 Standard Pressure Diaphragm Seal

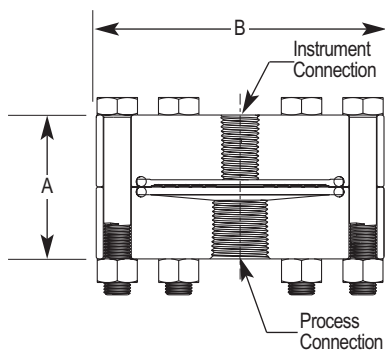

**Dimensional Data
Process Connection Size**

	1/4"	1/2"–3/4"	1"–1-1/2"
A	2.00	2.00	2.00
B	4.00	4.00	4.00

Type 10H Elevated Pressure Diaphragm Seal

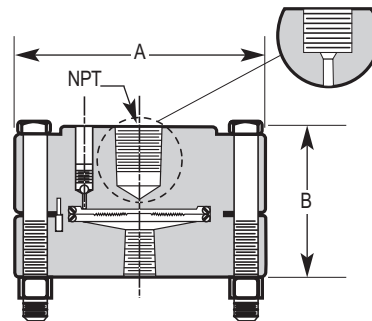

**Dimensional Data
Process Connection Size**

Pressure Rating	1/4"		3/8" - 1 1/2"	
	A	B	A	B
5000	4.0	2.13	4.0	2.13
10000	4.0	2.13	4.0	2.13

Non-Metallic Lower Housing, Reduced Pressure Diaphragm Seals



TYPE 10L

- Designed for applications where typical metallic lower housings cannot withstand process media
- Maximum pressure rating is 200 psig
- Utilizes a replaceable diaphragm clamped between the flanged housings with an O-ring seal to create a leak-free union
- Process connection sizes from 1/4 inch NPT through 1-1/2 inch NPT
- Consider gauge size, pressure range, media composition, ambient and operating temperature, and maximum working pressure when selecting
- Fill fluid must be compatible with process media; i.e. Glycerine may become volatile in conjunction with a strong oxidizing agent such as chlorine, forms of oxygen or peroxide and nitric acids

PRODUCT SPECIFICATIONS

Suitable Pressure Gauge Sizes	2-1/2, 4, 4-1/2 and 6 Inch Will also operate with most transducers, transmitters and pressure switches
Minimum Working Pressure	0 psig to 30 psig through -30 inHg to 200 psig
Maximum Working Pressure	200 psig @ 140 °F
Operating Temperature	140°F MAX

Fill Fluid Temperature Table

Fill Fluid	Temperature Range (°F)
Glycerine*	30 - 300
Silicone 200-10	-35 - 450
Silicone 704	30 - 520
Silicone 710	30 - 650
Silicone 550	-40 - 600
Silicone 510	-60 - 400
Fluorolube FS-5	-40 - 500
Silicone 200-350	0 - 300
Halocarbon Oil 6.3	-40 - 400
Ethylene Glycol	-30 - 300
Propylene Glycol	-50 - 200
Syltherm 800	-40 - 450
Mineral Oil	Note 1
Neobee M-20	-40 - 320

*Not recommended for use on vacuum applications
Note 1. To be advised

ORDERING INFORMATION								
TYPE	10L	200 psi						
INSTRUMENT CONNECTION SIZES	02	1/4 inch NPT						
	04	1/2 inch NPT						
UPPER HOUSING MATERIAL	C	Carbon Steel						
	S	316 Stainless Steel						
DIAPHRAGM MATERIAL	A	Tantalum	M	Monel 400	S	316 Stainless Steel	U	Titanium Grade 4
	H	Hastelloy C-276	N	Inconel 600	T	Teflon®	V	Viton®
O-RING MATERIAL	B	Buna N		T	Teflon®		V	Viton®
PROCESS CONNECTION SIZES	02	1/4 Inch NPT		06	3/4 Inch NPT		10	1-1/4 Inch NPT
	04	1/2 Inch NPT		08	1 Inch NPT		12	1-1/2 Inch NPT
(ASME and DIN Flanges Available Upon Request)								
LOWER HOUSING MATERIAL	KN	Kynar		PV	PVC		TG	Teflon® (Glass Filled)
	PP	Polypropylene		TC	Teflon® (Carbon Filled)			

EXAMPLE

- Model Selection
- Instrument Connection Size
- Upper Housing Material
- Diaphragm Material
- O-ring Material
- Process Connection Size
- Lower Housing Material

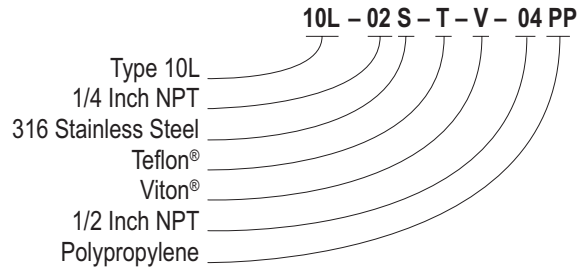

OUTLINE DIMENSIONS
Type 10L Reduced Pressure Diaphragm Seal

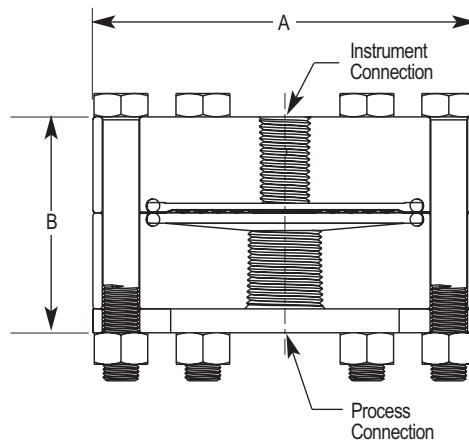

Dimensional Data
Process Connection Size

	1/4"	1/2" - 3/4"	1" - 1-1/2"
A	4.00	4.00	4.00
B Teflon Glass	2.25	2.25	2.25
B PVC Kynar	2.00	2.00	2.00

Tri-Clamp Sanitary Pressure Diaphragm Seals



TYPE 12

- Features a flush mount diaphragm and all welded construction, ideal for food & beverage, pharmaceutical and sanitary markets
- Wetted parts and all welded housing are constructed of 316 stainless steel for greater strength and durability
- Minimum working pressure 0 to 30 psi through -30 inHg to 600 psig
- Accommodates process connection pipes from 1-1/2 inch through 3 inch sizes
- Accommodates 2-1/2, 4, 4-1/2 and 6 inch gauge sizes
- Clamped connection allows ease of installation and removal of seal for maintenance and cleaning
- Wetted materials polished to Ra 32 or better
- Consider gauge size, pressure range, media composition, ambient and operating temperature, and maximum working pressure when selecting
- For process temperatures over 212° F a capillary or cooling element is recommended, contact factory to order
- Fill fluid must be compatible with process media; i.e. Glycerine may become volatile in conjunction with a strong oxidizing agent such as chlorine, forms of oxygen or peroxide and nitric acids

PRODUCT SPECIFICATIONS

Suitable Pressure Gauge Sizes	2-1/2, 4, 4-1/2 and 6 Inch Will also operate with most transducers, transmitters and pressure switches
Minimum Working Pressure	0 psig to 30 psig through -30 inHg to 600 psig
Maximum Working Pressure	Maximum Operating Pressure is Determined by the Clamping Device and Piping System – Please Consult Factory
Operating Temperature	Refer to fill fluid expansion factors table below

Note: NOSHOK pressure transmitters or transducers are not to be used in heat sterilization systems as stated in 3A Standard 74-03 paragraph D10.1.2

Diaphragm seal must be installed facing downward or in a vertical position for drainability. Do not install diaphragm seal facing in an upward position.

Fill Fluid Temperature Table

Fill Fluid	Temperature Range (°F)
Glycerine*	30 - 300
Silicone 200-10	-35 - 450
Silicone 704	30 - 520
Silicone 710	30 - 650
Silicone 550	-40 - 600
Silicone 510	-60 - 400
Fluorolube FS-5	-40 - 500
Silicone 200-350	0 - 300
Halocarbon Oil 6.3	-40 - 400
Ethylene Glycol	-30 - 300
Propylene Glycol	-50 - 200
Syltherm 800	-40 - 450
Mineral Oil	Note 1
Neobee M-20	-40 - 320

*Not recommended for use on vacuum applications
Note 1. To be advised

ORDERING INFORMATION				
TYPE	12*			
INSTRUMENT CONNECTION SIZES	02	1/4 inch NPT		
	04	1/2 inch NPT		
UPPER HOUSING MATERIAL	S 316 Stainless Steel			
DIAPHRAGM MATERIAL	S 316 Stainless Steel			
SANITARY PIPE SIZES	12	1-1/2 Inch	16	2 Inch
			20	2-1/2 Inch
			24	3 Inch
SANITARY SEAL CLAMPS & GASKETS				
SS LADISH TRI-CLAMP	CR12	1-1/2 Inch	CR16	2 Inch
			CR20	2-1/2 Inch
			CR24	3 Inch
BUNA GASKET	BG12	1-1/2 Inch	BG16	2 Inch
			BG20	2-1/2 Inch
			BG24	3 Inch
TEFLON GASKET	TG12	1-1/2 Inch	TG16	2 Inch
			TG20	2-1/2 Inch
			TG24	3 Inch

NOTE: For process temperatures over 212°F, a capillary or cooling element is recommended. Contact NOSHOK factory to order.

*Operating pressure is determined by the clamping device and piping system — Please consult factory.

EXAMPLE

- Model Selection
- Instrument Connection Size
- Upper Housing Material
- Diaphragm Material
- Sanitary Pipe Size
- SS Ladish Tri-Clamp (Optional)
- Gasket Material (Optional)

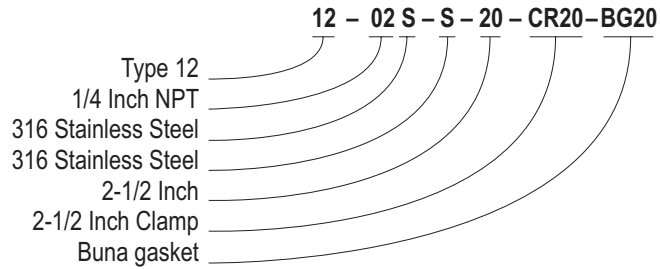

OUTLINE DIMENSIONS

Type 12 Ladish Tri-Clamp Sanitary Seal

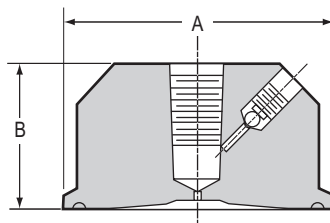

Nominal pipe size	1.5	2	3
Diaphragm Diameter Inches	1.4	1.9	2.4
A	1.984	2.516	3.579
B	1.25	1.25	1.25

Diaphragm Seals



TYPE 20

- Designed for applications requiring an NPT male threaded process connection and with a flush diaphragm
- Flush diaphragm construction prevents clogging and process material build-up
- Constructed with a 316 stainless steel housing and diaphragm for strength and durability
- Maximum pressure rating is 9,000 psi
- Available instrument connection sizes are 1/4 and 1/2 inch with a process connection size of 1/2 inch NPT male to 2 inch NPT male
- Consider gauge size, pressure range, media composition, ambient and operating temperature, and maximum working pressure when selecting
- For process temperatures over 212° F a capillary or cooling element is recommended, contact factory to order
- Fill fluid must be compatible with process media; i.e. Glycerine may become volatile in conjunction with a strong oxidizing agent such as chlorine, forms of oxygen or peroxide and nitric acids

PRODUCT SPECIFICATIONS

Suitable Pressure Instrument	Will operate with most transducers, transmitters and pressure switches
Minimum Working Pressure	0 psig to 30 psig through 0 psig to 9,000 psig*
Maximum Working Pressure	9,000 psig @ 100 °F
Operating Temperature	Refer to fill fluid expansion factors table below

* Depending on process connection size

Fill Fluid Temperature Table

Fill Fluid	Temperature Range (°F)
Glycerine*	30 - 300
Silicone 200-10	-35 - 450
Silicone 704	30 - 520
Silicone 710	30 - 650
Silicone 550	-40 - 600
Silicone 510	-60 - 400
Fluorolube FS-5	-40 - 500
Silicone 200-350	0 - 300
Halocarbon Oil 6.3	-40 - 400
Ethylene Glycol	-30 - 300
Propylene Glycol	-50 - 200
Syltherm 800	-40 - 450
Mineral Oil	Note 1
Neobee M-20	-40 - 320

*Not recommended for use on vacuum applications
Note 1. To be advised

ORDERING INFORMATION			
TYPE	20	9,000 psi	
INSTRUMENT CONNECTION SIZES	02	1/4 inch NPT	
	04	1/2 inch NPT	
HOUSING MATERIAL	S	316 Stainless Steel	
DIAPHRAGM MATERIAL	S	316 Stainless Steel	
PROCESS CONNECTION SIZES	04	08	16
	1/2 Inch NPT	1 Inch NPT	2 Inch NPT
	06	12	
	3/4 Inch NPT	1-1/2 Inch NPT	

NOTE: For process temperatures over 212°F, a capillary or cooling element is recommended. Contact NOSHOK factory to order.

EXAMPLE

Model Selection
Instrument Connection Size
Housing Material
Diaphragm Material
Process Connection Size

20 - 02 S - S - 06

Type 20
1/4 Inch NPT
316 Stainless Steel
316 Stainless Steel
3/4 Inch NPT

OUTLINE DIMENSIONS

Type 20 Front Flush Style Diaphragm Seal

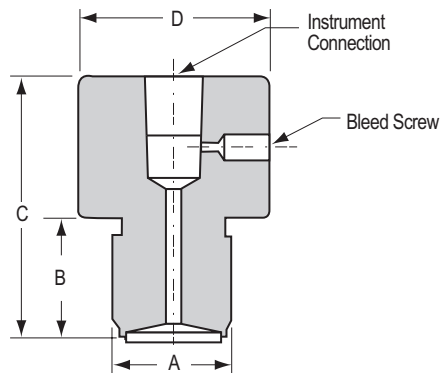

A	B	C	D
1/2" NPT	0.8	1.9	1.50
3/4" NPT	0.8	1.8	1.63
1" NPT	1.1	2.5	1.75
1 1/2" NPT	1.2	2.0	2.00
2" NPT	1.2	2.4	2.63

Diaphragm Seals



TYPE 25/25H

- Designed to isolate the pressure measuring instrument from corrosive or viscous process media
- Utilize an all welded, all metallic housing design to eliminate potential leak paths
- Maximum pressure rating is 2,500 psi
- For use with gauges with dial sizes of 2-1/2 inches and smaller, and pressure ranges no less than 100 psig
- Housing and diaphragm offered in a variety of materials to suit most applications
- A flushing port is available to clean wetted areas and prevent process media build up
- Consider gauge size, pressure range, media composition, ambient and operating temperature, and maximum working pressure when selecting
- For process temperatures over 212° F a capillary or cooling element is recommended, contact factory to order
- Fill fluid must be compatible with process media; i.e. Glycerine may become volatile in conjunction with a strong oxidizing agent such as chlorine, forms of oxygen or peroxide and nitric acids

PRODUCT SPECIFICATIONS

Suitable Pressure Gauge Sizes	2-1/2 Inch Will also operate with most transducers, transmitters and pressure switches
Minimum Working Pressure	25: 0 psig to 100 psig through 0 psig to 2,500 psig 25H: 0 psig to 100 psig through 0 psig to 5,000 psig
Maximum Working Pressure	25: 2,500 psig @ 100 °F 25H: 5,000 psig @ 100 °F
Operating Temperature	Refer to fill fluid expansion factors table below

Fill Fluid Temperature Table

Fill Fluid	Temperature Range (°F)
Glycerine*	30 - 300
Silicone 200-10	-35 - 450
Silicone 704	30 - 520
Silicone 710	30 - 650
Silicone 550	-40 - 600
Silicone 510	-60 - 400
Fluorolube FS-5	-40 - 500
Silicone 200-350	0 - 300
Halocarbon Oil 6.3	-40 - 400
Ethylene Glycol	-30 - 300
Propylene Glycol	-50 - 200
Syltherm 800	-40 - 450
Mineral Oil	Note 1
Neobee M-20	-40 - 320

*Not recommended for use on vacuum applications
Note 1. To be advised

ORDERING INFORMATION			
TYPE	25	2,500 psi	25H 5,000 psi
INSTRUMENT CONNECTION SIZES	02	1/4 inch NPT	
	04	1/2 inch NPT	
UPPER HOUSING MATERIAL	M	Monel 400	S 316 Stainless Steel
	P	Carpenter 20	
DIAPHRAGM MATERIAL	H	Hastelloy C-276	P Carpenter 20 ¹
	M	Monel 400 ¹	S 316 Stainless Steel
PROCESS CONNECTION SIZES	02	1/4 Inch NPT	
	04	1/2 Inch NPT	
LOWER HOUSING MATERIAL	H	Hastelloy C-276	P Carpenter 20
	M	Monel 400	S 316 Stainless Steel
FLUSHING CONNECTION	1F	1/8 Inch NPT	
	2F	1/4 Inch NPT	

1) When selecting a Monel or Carpenter 20 Diaphragm, the upper & lower housing must be the same material

NOTE: For process temperatures over 212°F, a capillary or cooling element is recommended. Contact NOSHOK factory to order.

EXAMPLE

- Model Selection**
- Instrument Connection Size**
- Upper Housing Material**
- Diaphragm Material**
- Process Connection Size**
- Lower Housing Material**
- Flushing Connection (Optional)**

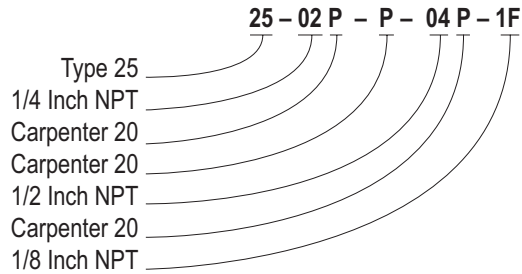

OUTLINE DIMENSIONS

Type 25/25H All Welded Standard Pressure Diaphragm Seal

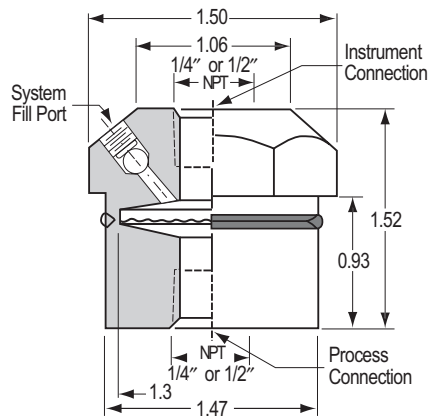

High Displacement Diaphragm Seals



TYPE 29

- An off-line seal with a threaded connection and all welded, all metallic housing design that does not utilize an o-ring or gasket
- Designed with a larger diameter diaphragm for higher displacement capability
- Maximum pressure rating is 2,500 psi
- A variety of upper and lower housing and diaphragm materials are available to suit most applications
- A flushing port is available to clean wetted areas and prevent process media build up
- Consider gauge size, pressure range, media composition, ambient and operating temperature, and maximum working pressure when selecting
- For process temperatures over 212° F a capillary or cooling element is recommended, contact factory to order
- Fill fluid must be compatible with process media; i.e. Glycerine may become volatile in conjunction with a strong oxidizing agent such as chlorine, forms of oxygen or peroxide and nitric acids

PRODUCT SPECIFICATIONS

Suitable Pressure Gauge Sizes	2-1/2, 4 and 4-1/2 Inch Will also operate with most transducers, transmitters and pressure switches
Minimum Working Pressure	0 psig to 30 psig through 0 psig to 2,500 psig
Maximum Working Pressure	2,500 psig @ 100 °F
Operating Temperature	Refer to fill fluid expansion factors table below

Fill Fluid Temperature Table

Fill Fluid	Temperature Range (°F)
Glycerine*	30 - 300
Silicone 200-10	-35 - 450
Silicone 704	30 - 520
Silicone 710	30 - 650
Silicone 550	-40 - 600
Silicone 510	-60 - 400
Fluorolube FS-5	-40 - 500
Silicone 200-350	0 - 300
Halocarbon Oil 6.3	-40 - 400
Ethylene Glycol	-30 - 300
Propylene Glycol	-50 - 200
Syltherm 800	-40 - 450
Mineral Oil	Note 1
Neobee M-20	-40 - 320

*Not recommended for use on vacuum applications
Note 1. To be advised

ORDERING INFORMATION			
TYPE	29	2,500 psi	
INSTRUMENT CONNECTION SIZES	02	1/4 inch NPT	
	04	1/2 inch NPT	
UPPER HOUSING MATERIAL	M	Monel 400	S 316 Stainless Steel
	P	Carpenter 20	
DIAPHRAGM MATERIAL	H	Hastelloy C-276	P Carpenter 20 ¹
	M	Monel 400 ¹	
	S	316 Stainless Steel	
PROCESS CONNECTION SIZES	02	1/4 Inch NPT	
	04	1/2 Inch NPT	
	06	3/4 Inch NPT	
	08	1 Inch NPT	
LOWER HOUSING MATERIAL	H	Hastelloy C-276	P Carpenter 20
	M	Monel 400	
	S	316 Stainless Steel	
FLUSHING CONNECTION	1F	1/8 Inch NPT	
	2F	1/4 Inch NPT	

1) When selecting a Monel or Carpenter 20 Diaphragm, the upper & lower housing must be the same material

NOTE: For process temperatures over 212°F, a capillary or cooling element is recommended. Contact NOSHOK factory to order.

EXAMPLE

- Model Selection**
- Instrument Connection Size**
- Upper Housing Material**
- Diaphragm Material**
- Process Connection Size**
- Lower Housing Material**
- Flushing Connection (Optional)**

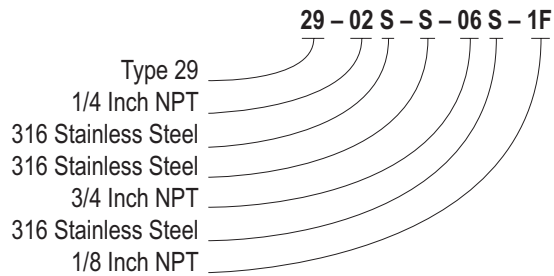

OUTLINE DIMENSIONS

**Type 29 High Displacement,
All Welded Diaphragm Seal**

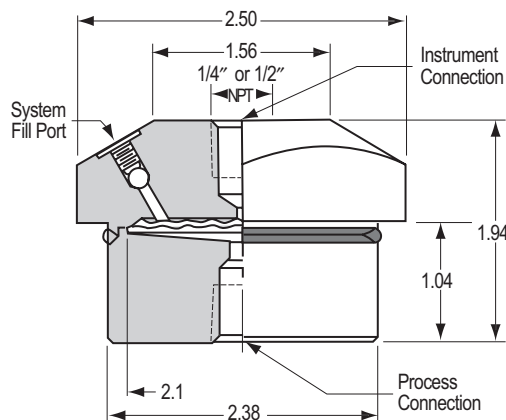

Standard and Elevated Pressure Welded Diaphragm Seals



TYPE 30, 30H & 30H1

- Utilizes an all metallic diaphragm welded to the upper housing to allow field replacement of the lower housing while maintaining continuity of the measuring system
- A wide variety of instrument and process connections are available
- A flushing port is available to clean wetted areas and prevent process media build up
- Consider gauge size, pressure range, media composition, ambient and operating temperature, and maximum working pressure when selecting
- For process temperatures over 212° F a capillary or cooling element is recommended, contact factory to order
- Fill fluid must be compatible with process media; i.e. Glycerine may become volatile in conjunction with a strong oxidizing agent such as chlorine, forms of oxygen or peroxide and nitric acids

PRODUCT SPECIFICATIONS

Suitable Pressure Gauge Sizes	2-1/2, 4, 4-1/2 and 6 Inch Will also operate with most transducers, transmitters and pressure switches
Minimum Working Pressure	30: 0 psig to 30 psig through -30" Hg to 2,500 psig 30H, 30H1: 0 psig to 30 psig through 0 psig to 10,000 psig
Maximum Working Pressure	30: 2,500 psig @ 100 °F 30H, 30H1: 5,000 psig, 10,000 psig @ 100 °F
Operating Temperature	Refer to fill fluid expansion factors table below

Fill Fluid Temperature Table

Fill Fluid	Temperature Range (°F)
Glycerine*	30 - 300
Silicone 200-10	-35 - 450
Silicone 704	30 - 520
Silicone 710	30 - 650
Silicone 550	-40 - 600
Silicone 510	-60 - 400
Fluorolube FS-5	-40 - 500
Silicone 200-350	0 - 300
Halocarbon Oil 6.3	-40 - 400
Ethylene Glycol	-30 - 300
Propylene Glycol	-50 - 200
Syltherm 800	-40 - 450
Mineral Oil	Note 1
Neobee M-20	-40 - 320

*Not recommended for use on vacuum applications
Note 1. To be advised

TYPE 30, 30H & 30H1

ORDERING INFORMATION DIMENSIONS

ORDERING INFORMATION						
TYPE	30	2,500 psi	30H	5,000 psi	30H1	10,000 psi
INSTRUMENT CONNECTION SIZES	02	1/4 inch NPT	04	1/2 inch NPT		
UPPER HOUSING MATERIAL	C	Carbon Steel	P	Carpenter 20	U	Titanium Grade 4
	M	Monel 400	S	316 Stainless Steel		
DIAPHRAGM MATERIAL	A	Tantalum	M	Monel 400 ¹	P	Carpenter 20 ¹
	H	Hastelloy C-276	N	Inconel 600	S	316 Stainless Steel
SEAL GASKET MATERIAL	H	Silver Plated HC (5,000 psi and above)	S	Silver Plated SS (5,000 psi and above)	V	Viton®
	R	Klingersil C-4401 (Rated to 1,500 psi)	T	Teflon®		
PROCESS CONNECTION SIZES	02	1/4 Inch NPT	06	3/4 Inch NPT	10	1-1/4 Inch NPT
	04	1/2 Inch NPT	08	1 Inch NPT	12	1-1/2 Inch NPT
		(ASME and DIN Flanges Available Upon Request)				
LOWER HOUSING MATERIAL	C	Carbon Steel	M	Monel 400	P	Carpenter 20
	H	Hastelloy C-276	N	Inconel 600	S	316 Stainless Steel
FLUSHING CONNECTION²	1F	1/8 Inch NPT	2F	1/4 Inch NPT		

1) When selecting a Monel 400, Carpenter 20 or Titanium Grade 4 Diaphragm, the upper housing must be the same material

2) Not available on 10,000 psi model.

NOTE: For process temperatures over 212°F, a capillary or cooling element is recommended. Contact NOSHOK factory to order.

EXAMPLE

Model Selection
Instrument Connection Size
Upper Housing Material
Diaphragm Material
Seal Gasket Material
Process Connection Size
Lower Housing Material
Flushing Connection (Optional)

30 - 04 S - S - R - 04 S - 1F

Type 30
 1/2 Inch NPT
 316 Stainless Steel
 316 Stainless Steel
 Klingersil C-4401
 1/2 Inch NPT
 316 Stainless Steel
 1/8 Inch NPT

OUTLINE DIMENSIONS

Type 30 Standard Pressure Diaphragm Seal

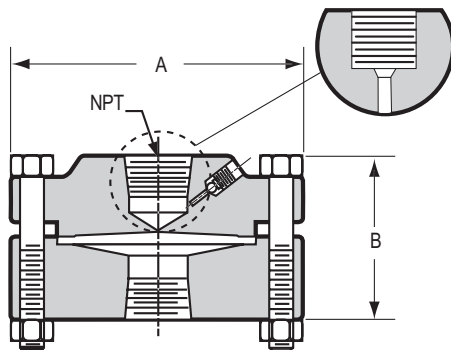

Dimensional Data
Process Connection Size

	1/8" - 1/4"	3/8" - 1-1/2"
A	3.5	3.5
B	1.56	2.00

Type 30H Elevated Pressure Diaphragm Seal

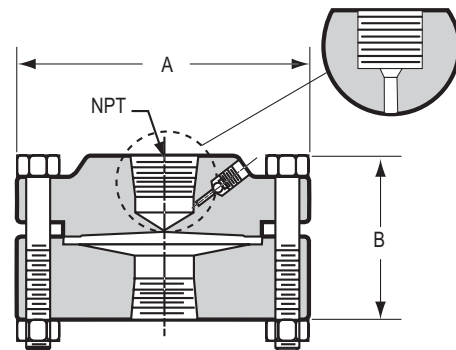

Dimensional Data
Process Connection Size

Pressure Rating	1/8"-1/4"		3/8"-1/2"	
	A	B	A	B
5000	4.0	2.25	4.0	2.25
10000	4.0	2.31	4.0	2.31

Reduced Pressure Welded Diaphragm Seals



TYPE 30L

- Designed for lower pressure applications
- Utilizes an all metallic diaphragm welded to the upper housing to allow replacement of the non-metallic lower housing while maintaining continuity of the measuring system
- Maximum pressure rating is 200 psi
- A flushing port is available to clean wetted areas and prevent process media build up
- Consider gauge size, pressure range, media composition, ambient and operating temperature, and maximum working pressure when selecting
- Maximum temperature rating is 140° F
- Fill fluid must be compatible with process media; i.e. Glycerine may become volatile in conjunction with a strong oxidizing agent such as chlorine, forms of oxygen or peroxide and nitric acids

PRODUCT SPECIFICATIONS

Suitable Pressure Gauge Sizes	2-1/2, 4, 4-1/2 and 6 Inch Will also operate with most transducers, transmitters and pressure switches
Minimum Working Pressure	0 psig to 30 psig through -30 Hg to 200 psig
Maximum Working Pressure	200 psig @ 140 °F
Operating Temperature	140°F MAX

Fill Fluid Temperature Table

Fill Fluid	Temperature Range (°F)
Glycerine*	30 - 300
Silicone 200-10	-35 - 450
Silicone 704	30 - 520
Silicone 710	30 - 650
Silicone 550	-40 - 600
Silicone 510	-60 - 400
Fluorolube FS-5	-40 - 500
Silicone 200-350	0 - 300
Halocarbon Oil 6.3	-40 - 400
Ethylene Glycol	-30 - 300
Propylene Glycol	-50 - 200
Syltherm 800	-40 - 450
Mineral Oil	Note 1
Neobee M-20	-40 - 320

*Not recommended for use on vacuum applications
Note 1. To be advised

ORDERING INFORMATION						
TYPE	30L	200 psi				
INSTRUMENT CONNECTION SIZES	02	1/4 inch NPT				
	04	1/2 inch NPT				
UPPER HOUSING MATERIAL	C	Carbon Steel	P	Carpenter 20	U	Titanium Grade 4
	M	Monel 400	S	316 Stainless Steel		
DIAPHRAGM MATERIAL	A	Tantalum	M	Monel 400 ¹	P	Carpenter 20 ¹
	H	Hastelloy C-276	N	Inconel 600	S	316 Stainless Steel
SEAL GASKET MATERIAL	R	CGR 2750	T	Teflon®	V	Viton®
PROCESS CONNECTION SIZES	02	1/4 Inch NPT		06	3/4 Inch NPT	
	04	1/2 Inch NPT		08	1 Inch NPT (ASME and DIN Flanges Available Upon Request)	
LOWER HOUSING MATERIAL	KN	Kynar	PV	PVC	TG	Teflon® (Glass Filled)
	PP	Polypropylene	TC	Teflon® (Carbon Filled)		

1) When selecting a Monel 400, Carpenter 20 or Titanium Grade 4 Diaphragm, the upper housing must be the same material

EXAMPLE

- Model Selection
- Instrument Connection Size
- Upper Housing Material
- Diaphragm Material
- Seal Gasket Material
- Process Connection Size
- Lower Housing Material

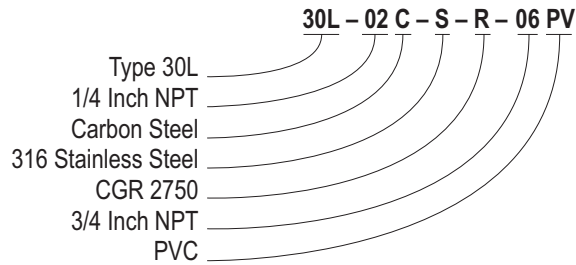

OUTLINE DIMENSIONS

Type 30L Reduced Pressure Diaphragm Seal

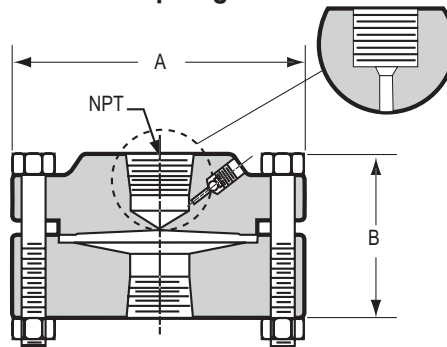

**Dimensional Data
Process Connection Size**

PVC-Kynar-Polypropylene			
	1/8" - 1/4"	3/8"-1"	1-1/4"-1-1/2"
A	4.0	4.0	4.0
B	2.00	2.00	2.00
Teflon-Glass/Carbon			
A	4.0	4.0	4.0
B	2.12	2.12	2.12

Options & Accessories by Gauge Series

100 SERIES STANDARD PRESSURE GAUGE OPTIONS & ACCESSORIES

• = Option/accessory is available

C = Consult factory for availability

N/C = No charge (consult factory for availability and minimum quantity)

STD = Standard stock model specification

MODEL NO.	15-100	15-110	15-120	20-100	20-110	20-120	20-148	25-100	25-110	25-120	40-100	Heavy Duty	
												40-105	40-115
CONNECTION													
Installed Panel Mount Clamp (PMC)		•	STD		•	STD			•	STD			
Uninstalled Panel Mount Clamp (15-110 PMC, 20-110 PMC, 25-110 PMC)		•	STD		•	STD			•	STD			
Polished Stainless Steel Bezel (SSB)		•	STD		•	STD			•	STD			•
Bayonet Ring													•
Black Rear Flange (BLRF)								•			•		
Stainless Steel Rear Flange (SSRF)												•	•
Black Front Flange (BLFF) - ABS Case		•			•				•		•	•	•
Chrome Front Flange (CFF) - ABS Case		•			•				•		•		
Polished 304SS Front Flange (SSFF)												•	•
Black Front Flange (SBFF) - Steel Case	C			C	•			•	•				
Chrome Front Flange (SCFF) - Steel Case	C	•		C	•			•	•				
Black Steel Case (BSC)	C	•	STD	C	•			•	•		•		
Stainless Steel Case (SSC)	C	•		C	•			•	•			STD w/ Blow- Out Plug	STD w/ Safety Relief Disc
Chrome Case (CRC)	C	•		C	•			•	•				
Flat Sided ABS Case (FAC)		•			•				•				
Black Cover Ring (BCR)**	C	•		C	•			•	•		•		
Stainless Steel Cover Ring (SSCR)**	C	•		C	•			•	•				
Chrome Cover Ring (CCR)**	C	•		C	•			•	•		•		
Polished Chrome Cover Ring (PCCR)**	C			C									
Chrome Adapter Ring (CAR)		•	•		•	•			•	•			C
Glass Lens (GL)*	C	N/C	•	C	N/C	•		N/C	N/C	•	N/C	N/C	N/C
Lexan Lens (LL)*								•	•				
Safety Glass Lens (SGL)*								•	•		•	•	•
Homalite Lens (HL)*			•			•				•			
Red Set Pointer (SP)**	•	C	C	•	•	C	•	•	•	C		•	•
Maximum Indicating Pointer (MIP)								C	C	C		•	•
Silicone Dampened Movement (SDM)	C	C	C	C	C	C	C	C	C	C	C	C	C
Laser Marking (LM)	•	•	•	•	•	•	•	•	•	•	•	•	•
Stainless Steel Tagging (ST)	•	•	•	•	•	•	•	•	•	•	•	•	•
Orifice - Brass Press Fit Sintered (20 Micron) (CPO)	•	•	•	•	•	•	•	•	•	•	•	•	•
Orifice - Brass Press Fit - 0.1mm (BP1)	•	•	•	•	•	•	•	•	•	•	•	•	•
Orifice - Brass Press Fit - 0.3mm (BP3)	•	•	•	•	•	•	•	•	•	•	•	•	•
Orifice - Brass Press Fit - 0.8mm (BP8)	•	•	•	•	•	•	•	•	•	•	•	•	•

STANDARD ORIFICE FOR 100 SERIES GAUGE IS 0.3 MM PRESS FIT, UNLESS OTHERWISE SPECIFIED.

* A steel, stainless or chrome case & cover ring must be additionally ordered when lenses other than Plexiglass™ are utilized on all 100 Series models

** Only 110 Models require a steel, stainless or chrome case & cover ring to be additionally ordered when utilizing a set pointer or cover ring. Please consult factory when a set pointer is to be utilized on a 120 Model.





200 SERIES LOW PRESSURE DIAPHRAGM (WATER COLUMN) GAUGE ACCESSORIES

300 SERIES BRASS CASE LIQUID FILLED GAUGE ACCESSORIES†

• = Option/accessory is available

C = Consult factory for availability

STD = Standard stock model specification





MODEL NO.	25-200	25-210	25-224	40-200
CONNECTION				
Black Rear Flange (BLRF)	•			
304SS Rear Flange (SSRF)				•
Black Front Flange (BLFF)	•	•		•
304SS Front Flange (SSFF)				•
Chrome Front Flange (CFF)	•	•		
Stainless Steel Case (SSC)	•	•		STD
Glass Lens (GL)*	•	•		•
Safety Glass Lens (SGL)*	•	•		•
Plexiglass™ Lens (PL)	STD	STD		•
Recalibrator Lens (RL)	•	•		
Red Set Pointer (SP)	•	•	•	•
Maximum Indicating Pointer (MIP)	•	•	•	C
Overpressure Protection (OP)	C	C	C	C
SS Bezel w/U-Clamp (SSB-U)		•		
Black Bezel w/U-Clamp (BB-U)		•		
Black Cover Ring (BCR)	•	•		
Stainless Steel Cover Ring (SSCR)	•	•		STD
Chrome Cover Ring (CCR)	•	•		
Laser Marking (LM)	•	•	•	•
Stainless Steel Tagging (ST)	•	•	•	•
Orifice - Brass Press Fit - 0.3mm (BP3)		•	•	•
Orifice - Brass Threaded - 0.3mm (BT3)	•	•	•	•

STANDARD ORIFICE FOR 200 SERIES GAUGE IS 0.3 MM PRESS FIT, UNLESS OTHERWISE SPECIFIED.

* A steel, stainless or chrome cover ring must be additionally ordered when lenses other than Plexiglass™ are utilized on all 200 Series models

Consult factory for additional non-stock and special accessory availability.

• = Option/accessory is available

CONNECTION				
Chrome Front Flange (CFF)	•	•	•	•
Chrome Front Flange (CFF) w/o Holes	•	•	•	•
Brass Front Flange (BFF)	•	•	•	•
Black Front Flange (BLFF)			•	•
304SS Rear Flange (SSRF)			•	•
Brass Rear Flange (BRF)	•	•		
Chrome Cover Ring (CCR)	•	•	•	
Chrome Bezel w/U-Clamp (CB-U)		•		•
Maximum Indicating Pointer (MIP)	•	•		
Lexan Lens (LL)			•	•
Glass Lens Overlay (GLO)	•	•		
Safety Glass Overlay (SGO)	•	•	•	•
Adapter Ring (AR)		•		•
7/16" - 20 Straight Thread*	•	•	•	•
Laser Marking (LM)	•	•	•	•
Stainless Steel Tagging (ST)	•	•	•	•
Orifice - Brass Threaded- 0.3mm (BT3)	•	•	•	•
Orifice - Brass Threaded - 0.4mm (BT4)	•	•	•	•
Orifice - Brass Threaded - 0.8mm (BT8)	•	•	•	•

STANDARD ORIFICE FOR 300 SERIES GAUGE IS 0.8 MM THREADED, UNLESS OTHERWISE SPECIFIED.

† See 300 Series Gauge Prices for any minimum quantities that may apply when ordering these accessories.

* Includes Viton® O-Ring. Consult factory for availability. Viton® is a registered trademark of DuPont Dow Elastomers.

Consult factory for additional non-stock and special accessory availability.

Options & Accessories by Gauge Series

400/500 SERIES ALL STAINLESS STEEL PRESSURE GAUGES DRY, LIQUID & AMMONIA GAUGE ACCESSORIES

- = Option/accessory is available
- C = Consult factory for availability
- STD = Standard stock model specification

MODEL NO.	15-401	15-411	25-400	25-410	40-400	40-410	60-400	60-410	25-406
			25-500	25-510	40-500	40-510	60-500	60-510	25-506
CONNECTION									
304 SS Front Flange (SSFF)				•	•	•	•	•	
304 SS Rear Flange (SSRF)			C	C	•	•	•	•	C
SS Bezel w/U-Clamp (SSB-U)						•		•	
Installed 304SS Panel Mount Clamp (SPMC)				•					
Uninstalled 304SS Panel Mount Clamp (25-459-1-55-PMC)				•					
Installed Steel Panel Mount Clamp (PMC)				•					
Uninstalled Steel Panel Mount Clamp (25-459-1-PMC)				•					
Flange Ring (FR)				•					
Flange Ring 304SS (SSFR)				•					
Adjustable Pointer (AP)					•	•	STD	STD	
Safety Glass Lens (SGL)			•	•	•	•	•	•	•
Maximum Indicating Pointer (MIP)			•	•	•	•	•	•	•
Red Set Pointer (SP)			•	•	•	•	•	•	•
Laser Marking (LM)	•	•	•	•	•	•	•	•	•
Stainless Steel Tagging (ST)	•	•	•	•	•	•	•	•	•
Orifice - 316SS Threaded Orifice - 0.8mm (ST8)	•	•	•	•	•	•	•	•	•
Orifice - 316SS Threaded Orifice - 0.5mm (ST5)	•	•	•	•	•	•	•	•	•

STANDARD ORIFICE FOR 400/500 SERIES GAUGE IS 0.8 MM THREADED, UNLESS OTHERWISE SPECIFIED.
Consult factory for additional non-stock and special accessory availability.

600/700 SERIES PROCESS GAUGE ACCESSORIES

- = Option/accessory is available

MODEL NO.	DRY		LIQUID FILLED	
	45-640	45-740	45-660	45-760
CONNECTION				
Safety Glass Lens (SGL)	•	•	•	•
Glass Lens (GL)	•	•	•	•
Maximum Indicating Pointer (MIP)	•	•	•	•
Uninstalled Black Panel Mount Ring (BPMR)	•	•	•	•
Uninstalled Chrome Panel Mount Ring (CPMR)	•	•	•	•
Manocont "Dampened" Movement (MDM)	•	•		
Overload Stop (OS)	•	•	•	•
Laser Marking (LM)	•	•	•	•
Stainless Steel Tagging (ST)	•	•	•	•
Orifice - Brass Press Fit - 0.3mm (BP3)	•		•	
Orifice - Brass Threaded - 0.8mm (BT8)	•		•	
Orifice - 316SS Threaded - 0.8mm (ST8)		•		•

STANDARD ORIFICE FOR 600/700 SERIES GAUGE IS 0.8 MM THREADED, UNLESS OTHERWISE SPECIFIED.

Consult factory for additional non-stock and special accessory availability.

800 SERIES PRECISION TEST GAUGE ACCESSORIES

- = Option/accessory is available

MODEL NO.	60-800
CONNECTION	
304 SS Front Flange (SSFF)	•
304 SS Rear Flange (SSRF)	•
Carrying Case (CC)	•
Laser Marking (LM)	•
Stainless Steel Tagging (ST)	•
Orifice - Brass Press Fit - 0.3mm (below 10,000 psi) (BP3)	•
Orifice - Brass Threaded - 0.8mm (below 10,000 psi) (BT8)	•
Orifice - 316SS Threaded - 0.8mm (10,000 - 20,000 psi) (ST8)	•

STANDARD ORIFICE FOR 600/700 SERIES GAUGE IS 0.8 MM THREADED, UNLESS OTHERWISE SPECIFIED.







Consult factory for additional non-stock and special accessory availability.

900 SERIES - LIQUID FILLED PRESSURE GAUGE ACCESSORIES

• = Option/accessory is available

C = Consult factory for availability

STD = Standard stock model specification

MODEL NO.	15-910	25-900	25-910	25-901	25-911	40-901	40-911
CONNECTION							
Chrome Flange Ring (CFR)			•		•		
304 SS Polished Flange Ring (SSFR)			•		•		
Installed 304SS Panel Mount Clamp (SPMC)			•		•		
Uninstalled 304SS Panel Mount Clamp (25-459-1-55-SPMC)			•		•		
Installed Steel Panel Mount Clamp (PMC)			•		•		
Uninstalled Steel Panel Mount Clamp (25-459-1-PMC)			•		•		
SS Bezel w/U-Clamp (SSB-U)							•
SS Bezel (SSB)			•				
Adjustable Pointer (AP)						•	•
Safety Glass Lens (SGL)				•	•	•	•
Black Front Flange (BLFF)		•	C				
Chrome Front Flange (CFF)		•	C				
304 SS Front Flange (SSFF)			•		•	•	•
304 SS Rear Flange (SSRF)						•	•
Black Cover Ring (BCR)		•					
Chrome Cover Ring (CCR)		•					
304 SS Cover Ring (SSCR)						STD	STD
Maximum Indicating Pointer (MIP)				•**	•**	•	•
7/16" - 20 Straight Thread*		•	•	•	•	•	•
Laser Marking (LM)	•	•	•	•	•	•	•
Stainless Steel Tagging (ST)	•	•	•	•	•	•	•
Orifice - Brass Press Fit - 0.3mm (BP3)	•	•	•	•	•	•	•
Orifice - Brass Threaded - 0.5mm (BT5)	•	•	•	•	•		
Orifice - Brass Threaded - 0.8mm BT8)						•	•

STANDARD ORIFICE FOR 900 SERIES GAUGE IS 0.3 MM PRESS FIT, UNLESS OTHERWISE SPECIFIED.

* Includes Viton® O-Ring. Consult factory for availability. Viton® is a registered trademark of DuPont Dow Elastomers.

** For ranges 60 psi and above. Minimum quantities may apply when ordering this accessory for a non-stocked pressure range. Consult factory.

Consult factory for additional non-stock and special accessory availability.

Options & Accessories

Panel Mounting/Flanges

- Many panel mounting options are available and can be installed in the field
- Options include:
 - Brass Front Flanges (BFF)
 - Black Painted Steel Front Flanges (BLFF)
 - Chrome Front Flanges (CFF)
 - Stainless Steel Front Flanges (SSFF)
 - Chrome Triangular Bezel with U-Clamp (CB-U)
 - Black Painted Steel Triangular Bezels with U-Clamp (BB-U-Clamp)
 - Stainless Steel Narrow Bezel Front Flanges (SSB-U)
 - Panel Mount Clamps (PMC)
- Chrome plated steel Adapter Rings (AR) are available in conjunction with several of these flanges to adapt to oversized panel cut outs, including:
 - Stainless Steel Flange Rings (SSFR)
 - Chrome Plated Steel Flange Rings (CFR)
 - Black or Chrome Panel Mount Rings (BPMR & CPMR)
- Rear Flanges (RF) for front of panel mounting are also available as a factory installed option on some models
- **See the Gauges Accessories & Options Chart for availability on specific models**



Panel Mount Clamp
20-110 PMC



Chrome Triangular Bezel
with U-Clamp



Cases and Cover Rings

Cases and Cover Rings

- The following cases and cover rings are available on many models as production options:
 - Black painted steel (BCR)
 - Chrome plated steel (CCR)
 - 304 Stainless steel (SSCR)
- **See the Gauges Accessories & Options Chart for availability on specific models**

Lenses

- A variety of lens options are available on many models as a production option:
 - Instrument Glass Lenses
 - Laminated Safety Glass Lenses
 - Plexiglass™ Lenses
 - Homalite Lenses (resistant to many industrial solvents)
- A steel or stainless case and cover ring is required when other than Plexiglass™ lenses are utilized
- Some models are also available with a solid front, safety case
- **See the Gauges Accessories & Options Chart for availability on specific models**

Maximum Indicating Pointers (MIP)

- An invaluable tool for identifying pressure spikes in a system
- Extremely helpful during system start up and troubleshooting
- MIPs add an additional $\pm 1\%$ error to the gauge because of the increased load on the bourdon tube
- On ranges of 60 psi and lower, MIPs may double the allowed error of the gauge



Maximum Indicating Pointer

Set Pointers (SP)

- Used to identify an operating minimum or maximum pressure or vacuum value
- Set pointers are available on all models



Set Pointers

Rubber Case Protectors (RCP)

- Ideal for gauges that are subjected to direct physical shock
- 2-1/2 inch covers are blue and 4 inch covers are black

Orifices

- Press-fit brass Orifices or threaded 316 Stainless Steel Orifices are available on all NOSHOK Pressure Gauges
- They are standard with .012" I.D or .032" I.D, depending on the model
- Orifices are used in a gauge to restrict the flow of rapidly increasing and decreasing pressures, reducing the immediate effect of pulsations and pressure spikes
- Orifices are recommended for all dynamic applications



Rubber Case Protectors

Recalibrators

- The option of an adjustment screw accessible through the dial facilitates re-setting the zero point without disassembling the gauge

Overpressure Protection

- Over pressure protection of up to 200% of the dial range is available on some models as a production option

Ammonia Refrigeration Gauges

- Ammonia Refrigeration Gauges with dials reading in both pressure and temperature are available in 400/500 Series 2-1/2 and 4 inch sizes



Ammonia Gauges

Liquid Filling Options

- Many NOSHOK gauges are available with liquid filling options
- Standard fill is Glycerine
- Optional fill liquids include Dow Corning 200® Silicone and Halocarbon, and a list of more...

Special Connections

- Available on most NOSHOK gauges
- Some examples include:
 - Metric threads
 - Female threads
 - Straight threads (flare or swivel type)
 - Special o-ring connections
- Please contact us with your requirements for prices, availability and minimum quantities

Reid Vapor Test Gauges

- Configuration includes a handle, special dial and special pressure port
- Available in 600/700 Series Gauges with pressure ranges of 0-5 psi, 0-15 psi and 0-30 psi

Options & Accessories

Receiver Gauges

- 3-15 psi Receiver Gauges are available in both 600 Series (Brass) and 700 Series (316 Stainless steel)

Metric Dials And Customized Special Dials

- Dual scale Metric Dials in psi/bar, psi/kPa and psi/kg/cm² are available on many models
- Certain other scales are available for specific sizes and ranges, such as single scale bar and kPa, refrigerant scales and altitude scales
- Please consult the factory for availability
- Customized Special Dials such as non-standard metric scale, tons of ram, lbs. of force, etc. are available in small quantities (as few as one piece) on some models



Metric Dials and Customized Special Dials

Certified Calibration

- Available on all NOSHOK Gauges
- Certified Calibration provides the user with a serial numbered gauge along with a calibration sheet against a primary pressure standard
- Traceable to the National Institute of Standards and Technology

Pressure Snubbers

Piston Type Snubbers

- Resist clogging and are self cleaning
- Five different sized pistons included with each snubber to ensure the correct amount of snubbing for virtually every application
- Available in brass and 316 Stainless steel in 1/4" NPT, 1/2" NPT or 7/16-20 SAE-4

Options & Accessories

Piston Type Snubbers Specifications

MODEL NO.	SIZE	MATERIAL	PRESSURE RATING
1325	1/4" NPT	Brass	6000 psi
1335	7/16-20 SAE-4	Brass	6000 psi
1350	1/2" NPT	Brass	6000 psi
5025	1/4" NPT	316 Stainless Steel	15000 psi
5050	1/2" NPT	316 Stainless Steel	15000 psi

DIMENSIONS		1/4" NPT	1/2" NPT	7/16-20 SAE-4
A	IN	0.812	1.125	0.812
	MM	20.6	28.6	20.6
B	IN	1.60	1.875	1.60
	MM	40.6	47.6	40.6
C	IN	1.04	1.25	1.24
	MM	26.4	31.8	31.5
D	IN	.56	0.625	0.36
	MM	14.2	15.9	9.1



Piston Type Snubbers

PISTON	SUGGESTED USE
A, B*	Gases
B, C	Water
C, D	Light Oil
E	Heavy Oil

* Snubber assembled and shipped with the B piston installed.

Sintered Snubbers

- Cost effective solution to protect expensive instrumentation
- Increases gauge readability by smoothing out pressure surges, pulsations and spikes
- Eliminates instrument failure due to pressure shock
- 5 basic elements available for each snubber to accommodate specific application needs
- Snubbing action achieved by utilizing a corrosion resistant 316 Stainless Steel sintered porous element
- Exotic materials or intermediate disc grades available on a per order basis
- Provides long service life with no moving parts to wear out

Options & Accessories

Sintered Snubbers Specifications

MODEL NO.	SIZE	MATERIAL	PRESSURE RATING
1125-X	1/4" NPT	Brass	6000 psi
1135-X	7/16-20 SAE-4	Brass	6000 psi
1150-X	1/2" NPT	Brass	6000 psi
5125-X	1/4" NPT	316 Stainless Steel	15000 psi
5150-X	1/2" NPT	316 Stainless Steel	15000 psi

NOTE: The "X" in the Model Number denotes the Disc option (example: 1135-C). See chart below for Disc options.

DIMENSIONS		1/4" NPT	1/2" NPT	7/16-20 SAE-4
A	IN	0.812	1.125	0.812
	MM	20.6	28.6	20.6
B	IN	1.60	1.875	1.60
	MM	40.6	47.6	40.6
C	IN	1.04	1.25	1.24
	MM	26.4	31.8	31.5
D	IN	.56	0.625	0.36
	MM	14.2	15.9	9.1



Sintered Snubbers



Sintered Snubbers Replacement Discs

Sintered Snubbers Replacement Disc Options

DISC OPTION	MODEL NO.	AVERAGE AIR FLOW ESTIMATE	SUGGESTED USE
A	PD8-A-SS1	0.25 L/MIN @ 1 psi	Gases
B	PD8-B-SS1	0.63 L/MIN @ 1 psi	Gases, Water
C	PD8-C-SS1	1.46 L/MIN @ 1 psi	Water, Light Oil
D	PD8-D-SS1	2.79 L/MIN @ 1 psi	Light Oil
E	PD8-E-SS1	3.14 L/MIN @ 1 psi	Heavy Oil

Pigtail Steam Syphons

Pigtail Steam Syphons

- Protect the instrument from the damaging effects of high temperature steam
- Recommended for use in all steam applications
- Available in 1/4" and 1/2" NPT sizes in welded steel, welded 316 Stainless steel or seamless 316 Stainless steel with ratings to 3,800 psi @ 850° F

Product Specifications

MODEL NO.	COIL STYLE	SIZE	MATERIAL
1225	90°	1/4" NPT	Welded Steel, Schedule 40
1250		1/2" NPT	Welded Steel, Schedule 80
2225		1/4" NPT	Welded 316SS, Schedule 40
2250		1/2" NPT	Welded 316SS, Schedule 80
1025	180°	1/4" NPT	Welded Steel, Schedule 40
1050		1/2" NPT	Welded Steel, Schedule 80
2025		1/4" NPT	Welded 316SS, Schedule 40
2050		1/2" NPT	Welded 316SS, Schedule 80
1425	270°	1/4" NPT	Welded Steel, Schedule 40
1450		1/2" NPT	Welded Steel, Schedule 80
2325		1/4" NPT	Welded 316SS, Schedule 40
2350		1/2" NPT	Welded 316SS, Schedule 80
1525	360°	1/4" NPT	Welded Steel, Schedule 40
1550		1/2" NPT	Welded Steel, Schedule 80
2525		1/4" NPT	Welded 316SS, Schedule 40
2550		1/2" NPT	Welded 316SS, Schedule 80

Pigtail Steam Syphons



1/4" NPT Steam Syphons Temperature vs. Pressure

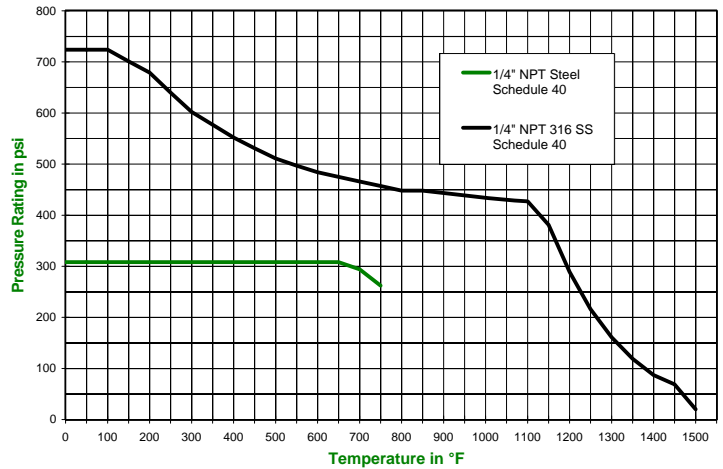

90° Syphon

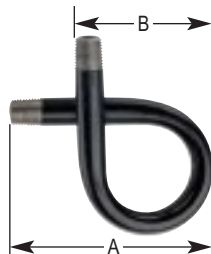

180° Syphon

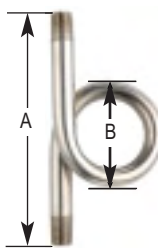

270° Syphon

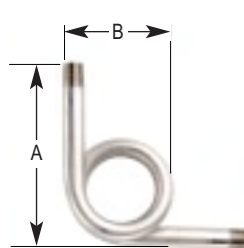

360° Syphon

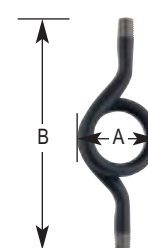

CONNECTION SIZE			1/4" NPT	1/2" NPT
90°	A	IN	4.25	6.5
		MM	107.95	165.1
90°	B	IN	2.625	4.0
		MM	66.675	101.6
180°	A	IN	5.5	8.875
		MM	139.7	225.425
180°	B	IN	2.5	4.0
		MM	63.5	101.6
270°	A	IN	4.5	7.5
		MM	114.3	190.5
270°	B	IN	2.625	4.0
		MM	66.675	101.6
360°	A	IN	7.25	12.0
		MM	184.15	304.8
360°	B	IN	2.625	4.125
		MM	66.675	104.775

1/2" NPT Steam Syphons Temperature vs. Pressure

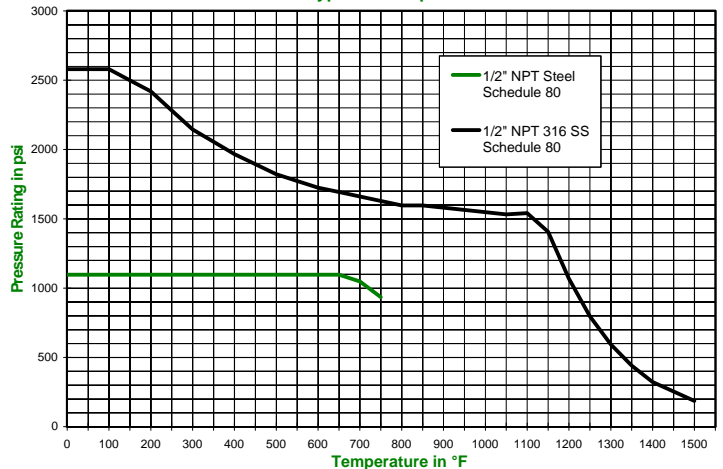

Swivel Adapter

- Temperature ratings: 15,000 psi @ 200° F and 3,000 psi @ 1,000° F
- Used with gauges and gauge valves to adjust the line of sight
- Rotates 360° to allow the connected instrument to be positioned in the desired direction
- The pressure connection is achieved with a tapered cone style compression fitting simply by tightening the swivel hex nut
- All 316 Stainless steel construction
- Standard with 1/2" NPT male process – 1/2" NPT female instrument connections
- Also available with 1/4" NPT connections

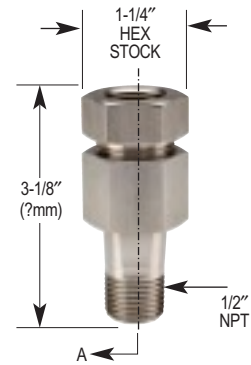

Magnetic Spring Contact Switch (MSCS)

- An excellent choice when an accurate pressure switch is required in addition to a reliable pressure gauge
- Fully adjustable by the user
- These switches are actuated by the pressure gauge pointer to provide accurate field adjustment
- A removable adjustment key makes them tamper-proof
- They operate with an extremely broad power supply, AC or DC up to 250V max. (30W 50 VA), allowing them to be used virtually anywhere in the world in addition to very remote applications with only DC battery pack power available
- Standard units consist of (2) two magnetic spring switches; either one or both switches may be used:
 - Switch (1) one is normally closed
 - Switch (2) two is normally open with operation referenced on rising (or increasing) pressure
- Magnetic Spring Contact Switches are available as a factory installed option on models 40-105, 40-115, 40-400 and 40-410
- The lowest full scale pressure range this switch may be used on is 0 psi to 60 psi because of the increased load on the pointer and bourdon tube
- A matching 4-pin connector with 5 feet of 4-wire and color coded shielded cable is standard



Magnetic Spring Contact Switch

SPECIFICATIONS

Type of Power	A.C. or D.C. 24 to 250V max
Maximum Amps	1.0 A
Maximum Switching Capacity	30W/50 VA
Gauge Accuracy	Add an additional $\pm 2\%$
Minimum Magnet Holding Force	1g
Contact Pin Material	Silver Tungsten
Ambient Temperature Limitation	0°F to 140°F (-18°C to 61°C)
Minimum Full Scale Pressure Range	0-60 psi

APPLICATIONS

- Air compressors
- Gas compressors
- Hydraulic and pneumatic circuitry
- Die-cast machinery
- Plastic injection molding machinery
- Anywhere accurate off/on switching capabilities based on pressure are required

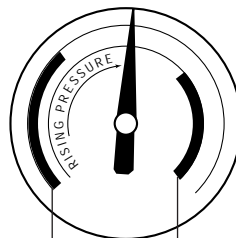

CONTACT NO. 1
Normally Closed,
Opens on Rising
Pressure

CONTACT NO. 2
Normally Open,
Closes on Rising
Pressure

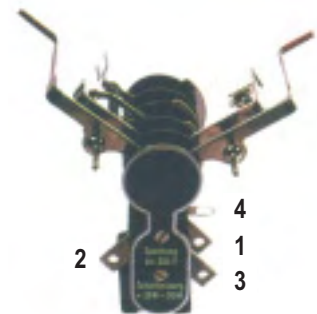

WIRING AND TERMINAL LOCATION

1. Contact Switch No. 1; Red or Black
2. Contact Switch No. 2; Blue
3. Power; Green or Brown
4. Ground; Yellow/Green Stripe

Accuracy/Standard Dial Configuration

Applies to:

100 Series Gauges: 4 inch 105 Series

200 Series Gauges: 4 inch

300 Series Gauges: 4 inch

400/500 Series Gauges: 4 and 6 inch

700 Series Gauges (LP): 4-1/2 inch

900 Series Gauges: 4 inch

ACCURACY: ±1.0% Full Scale ASME Grade 1A

Primary Scale			Secondary Scales								
Dial Range	Figure	Graduation	kPa	Figure	Graduation	kg/cm2	Figure	Graduation	bar	Figure	Graduation
-30 inHg to 0 psi	-5 inHg	-0.5 inHg	-100 kPa to 0 kPa	-20 kPa	-2 kPa	-1 kg/cm2 to 0 kg/cm2	-0.2 kg/cm2	-0.02 kg/cm2	-1 bar to 0 bar	-0.2 bar	-0.02 bar
-30 inHg to 15 psi	-10 inHg 5 psi	-1 inHg 0.5 psi	-100 kPa to 100 kPa	-50 kPa 50 kPa	-5 kPa 5 kPa	-1 kg/cm2 to 1.05 kg/cm2	-0.5 kg/cm2 0.5 kg/cm2	-0.05 kg/cm2 0.05 kg/cm2	-1 bar to 1 bar	-0.5 bar 0.5 bar	-0.05 bar 0.05 bar
-30 inHg to 30 psi	-10 inHg 5 psi	-1 inHg 0.2 psi	-100 kPa to 205 kPa	-50 kPa 50 kPa	-5 kPa 5 kPa	-1 kg/cm2 to 2.10 kg/cm2	-1 kg/cm2 0.5 kg/cm2	-0.1 kg/cm2 0.01 kg/cm2	-1 bar to 2.05 bar	-0.5 bar 0.5 bar	-0.05 bar 0.05 bar
-30 inHg to 60 psi	-30 inHg 10 psi	-2 inHg 1 psi	-100 kPa to 410 kPa	-100 kPa 100 kPa	-10 kPa 10 kPa	-1 kg/cm2 to 4.2 kg/cm2	-1 kg/cm2 1 kg/cm2	-0.1 kg/cm2 0.1 kg/cm2	-1 bar to 4 bar	-1 bar 1 bar	-1 bar .1 bar
-30 inHg to 100 psi	-30 inHg 20 psi	-5 inHg 2 psi	-100 kPa to 680 kPa	-100 kPa 200 kPa	-20 kPa 20 kPa	-1 kg/cm2 to 7 kg/cm2	-1 kg/cm2 2 kg/cm2	-0.2 kg/cm2 0.2 kg/cm2	-1 bar to 6.8 bar	-1 bar 2 bar	-0.2 bar 0.2 bar
-30 inHg to 160 psi	-30 inHg 20 psi	-10 inHg 2 psi	-100 kPa to 1100 kPa	-100 kPa 200 kPa	-20 kPa 20 kPa	-1 kg/cm2 to 11.2 kg/cm2	-1 kg/cm2 2 kg/cm2	-0.2 kg/cm2 0.2 kg/cm2	-1 bar to 11 bar	-1 bar 2 bar	-0.2 bar 0.2 bar
-30 inHg to 200 psi	-30 inHg 40 psi	-5 inHg 4 psi	-100 kPa to 1360 kPa	-100 kPa 400 kPa	-20 kPa 40 kPa	-1 kg/cm2 to 14 kg/cm2	-1 kg/cm2 4 kg/cm2	-0.2 kg/cm2 0.4 kg/cm2	-1 bar to 13.6 bar	-1 bar 4 bar	-0.2 bar 0.4 bar
-30 inHg to 300 psi	-30 inHg 50 psi	-10 inHg 5 psi	-100 kPa to 2050 kPa	-100 kPa 500 kPa	-50 kPa 50 kPa	-1 kg/cm2 to 21 kg/cm2	-1 kg/cm2 5 kg/cm2	-0.5 kg/cm2 0.5 kg/cm2	-1 bar to 20.5 bar	-1 bar 5 bar	-0.5 bar 0.5 bar
0 psi to 15 psi	3 psi	0.2 psi	0 kPa to 100 kPa	30 kPa	2 kPa	0 kg/cm2 to 1.05 kg/cm2	0.3 kg/cm2	0.05 kg/cm2	0 bar to 1.00 bar	0.3 bar	0.02 bar
0 psi to 30 psi	5 psi	0.5 psi	0 kPa to 205 kPa	50 kPa	5 kPa	0 kg/cm2 to 2.1 kg/cm2	0.5 kg/cm2	0.1 kg/cm2	0 bar to 2.05 bar	0.5 bar	0.05 bar
0 psi to 60 psi	10 psi	1 psi	0 kPa to 410 kPa	100 kPa	10 kPa	0 kg/cm2 to 4.2 kg/cm2	1 kg/cm2	0.2 kg/cm2	0 bar to 4.10 bar	1 bar	0.01 bar
0 psi to 100 psi	20 psi	2 psi	0 kPa to 680 kPa	200 kPa	20 kPa	0 kg/cm2 to 7 kg/cm2	2 kg/cm2	0.2 kg/cm2	0 bar to 6.8 bar	2 bar	0.2 bar
0 psi to 160 psi	20 psi	2 psi	0 kPa to 1100 kPa	200 kPa	20 kPa	0 kg/cm2 to 11.0 kg/cm2	2 kg/cm2	0.4 kg/cm2	0 bar to 11 bar	2 bar	0.2 bar
0 psi to 200 psi	40 psi	4 psi	0 kPa to 1360 kPa	400 kPa	40 kPa	0 kg/cm2 to 14 kg/cm2	4 kg/cm2	0.5 kg/cm2	0 bar to 13.6 bar	4 bar	0.4 bar
0 psi to 300 psi	50 psi	5 psi	0 kPa to 2050 kPa	500 kPa	50 kPa	0 kg/cm2 to 21 kg/cm2	5 kg/cm2	0.5 kg/cm2	0 bar to 20.5 bar	5 bar	0.5 bar
0 psi to 400 psi	50 psi	5 psi	0 kPa to 2700 kPa	500 kPa	50 kPa	0 kg/cm2 to 28 kg/cm2	5 kg/cm2	0.5 kg/cm2	0 bar to 27.0 bar	5 bar	0.5 bar
0 psi to 600 psi	100 psi	10 psi	0 kPa to 4100 kPa	1000 kPa	100 kPa	0 kg/cm2 to 42 kg/cm2	10 kg/cm2	1 kg/cm2	0 bar to 41.0 bar	10 bar	1 bar
0 psi to 1000 psi	200 psi	20 psi	0 kPa to 6800 kPa	2000 kPa	200 kPa	0 kg/cm2 to 70 kg/cm2	20 kg/cm2	2 kg/cm2	0 bar to 68 bar	20 bar	2 bar
0 psi to 1500 psi	300 psi	20 psi	0 kPa to 10000 kPa	3000 kPa	200 kPa	0 kg/cm2 to 105 kg/cm2	30 kg/cm2	2 kg/cm2	0 bar to 100 bar	30 bar	2 bar
0 psi to 2000 psi	400 psi	40 psi	0 kPa to 13600 kPa	4000 kPa	400 kPa	0 kg/cm2 to 140 kg/cm2	40 kg/cm2	4 kg/cm2	0 bar to 136 bar	40 bar	4 bar
0 psi to 3000 psi	500 psi	50 psi	0 kPa to 20500 kPa	5000 kPa	500 kPa	0 kg/cm2 to 210 kg/cm2	50 kg/cm2	5 kg/cm2	0 bar to 205 bar	50 bar	5 bar
0 psi to 5000 psi	1000 psi	100 psi	0 kPa to 34000 kPa	10000 kPa	1000 kPa	0 kg/cm2 to 350 kg/cm2	100 kg/cm2	10 kg/cm2	0 bar to 340 bar	100 bar	10 bar
0 psi to 6000 psi	1000 psi	100 psi	0 kPa to 41000 kPa	10000 kPa	1000 kPa	0 kg/cm2 to 420 kg/cm2	100 kg/cm2	10 kg/cm2	0 bar to 410 bar	100 bar	10 bar
0 psi to 7500 psi	1500 psi	100 psi	0 kPa to 51000 kPa	10000 kPa	1000 kPa	0 kg/cm2 to 520 kg/cm2	100 kg/cm2	10 kg/cm2	0 bar to 510 bar	100 bar	10 bar
0 psi to 10000 psi	2000 psi	200 psi	0 kPa to 68000 kPa	20000 kPa	2000 kPa	0 kg/cm2 to 700 kg/cm2	200 kg/cm2	20 kg/cm2	0 bar to 680 bar	200 bar	20 bar
0 psi to 15000 psi	3000 psi	200 psi	0 kPa to 103000 kPa	30000 kPa	2000 kPa	0 kg/cm2 to 1050 kg/cm2	300 kg/cm2	20 kg/cm2	0 bar to 1030 bar	300 bar	20 bar
0 psi to 20000 psi	4000 psi	400 psi	0 kPa to 136000 kPa	40000 kPa	4000 kPa	0 kg/cm2 to 1400 kg/cm2	400 kg/cm2	40 kg/cm2	0 bar to 1360 bar	400 bar	40 bar
0 psi to 30000 psi	5000 psi	500 psi	0 kPa to 205000 kPa	50000 kPa	5000 kPa	0 kg/cm2 to 2100 kg/cm2	500 kg/cm2	50 kg/cm2	0 bar to 2050 bar	500 bar	50 bar
0 psi to 40000 psi	5000 psi	500 psi	0 kPa to 270000 kPa	50000 kPa	5000 kPa	0 kg/cm2 to 2800 kg/cm2	500 kg/cm2	50 kg/cm2	0 bar to 2700 bar	500 bar	50 bar
0 psi to 50000 psi	10000 psi	1000 psi	0 kPa to 340000 kPa	100000 kPa	100000 kPa	0 kg/cm2 to 3500 kg/cm2	1000 kg/cm2	100 kg/cm2	0 bar to 3400 bar	1000 bar	100 bar
0 psi to 60000 psi	10000 psi	1000 psi	0 kPa to 410000 kPa	100000 kPa	100000 kPa	0 kg/cm2 to 4200 kg/cm2	1000 kg/cm2	100 kg/cm2	0 bar to 4100 bar	1000 bar	100 bar
0 psi to 75000 psi	15000 psi	1000 psi	0 kPa to 510000 kPa	100000 kPa	100000 kPa	0 kg/cm2 to 5200 kg/cm2	1000 kg/cm2	100 kg/cm2	0 bar to 5100 bar	1000 bar	100 bar
0 psi to 100000 psi	20000 psi	2000 psi	0 kPa to 680000 kPa	200000 kPa	200000 kPa	0 kg/cm2 to 7000 kg/cm2	2000 kg/cm2	200 kg/cm2	0 bar to 6800 bar	2000 bar	100 bar

Accuracy/Standard Dial Configuration

Applies to:

100 Series Gauges: 4 inch 100 Series

200 Series Gauges: 2-1/2 inch

300 Series Gauges: 2-1/2 inch

400/500 Series Gauges: 2-1/2 inch

900 Series Gauges: 2-1/2 inch

ACCURACY: ±1.5% Full Scale ASME Grade 2A											
Primary Scale				Secondary Scales							
Dial Range	Figure	Graduation	kPa	Figure	Graduation	kg/cm ²	Figure	Graduation	bar	Figure	Graduation
-30 inHg to 0 psi	-5 inHg	-0.5inHg	-100 kPa to 0 kPa	-20 kPa	-2 kPa	-1 kg/cm ² to 0 kg/cm ²	-0.2 kg/cm ²	-0.02 kg/cm ²	-1 bar to 0 bar	-0.2 bar	-0.02 bar
-30 inHg to 15 psi	-10 inHg 5 psi	-1 inHg 0.5 psi	-100 kPa to 100 kPa	-50 kPa 50 kPa	-5 kPa 2 kPa	-1 kg/cm ² to 1.05 kg/cm ²	-0.5 kg/cm ² 0.5 kg/cm ²	-0.05 kg/cm ² 0.05 kg/cm ²	-1 bar to 1 bar	-0.5 bar 0.5 bar	-0.05 bar 0.05 bar
-30 inHg to 30 psi	-30 inHg 10 psi	-2 inHg 1 psi	-100 kPa to 205 kPa	-100 kPa 100 kPa	-10 kPa 10 kPa	-1 kg/cm ² to 2.10 kg/cm ²	-1 kg/cm ² 1 kg/cm ²	-0.1 kg/cm ² 0.1 kg/cm ²	-1 bar to 2.05 bar	-1 bar 1 bar	-0.1 bar 0.1 bar
-30 inHg to 60 psi	-30 inHg 20 psi	-5 inHg 2 psi	-100 kPa to 410 kPa	-100 kPa 200 kPa	-20 kPa 20 kPa	-1 kg/cm ² to 4.2 kg/cm ²	-1 kg/cm ² 2 kg/cm ²	-2 kg/cm ² 0.2 kg/cm ²	-1 bar to 4 bar	-1 bar 2 bar	-0.2 bar 0.2 bar
-30 inHg to 100 psi	-30 inHg 20 psi	-5 inHg 2 psi	-100 kPa to 680 kPa	-100 kPa 200 kPa	-20 kPa 20 kPa	-1 kg/cm ² to 7 kg/cm ²	-1 kg/cm ² 2 kg/cm ²	-0.2 kg/cm ² 0.2 kg/cm ²	-1 bar to 6.8 bar	-1 bar 2 bar	-0.2 bar 0.2 bar
-30 inHg to 160 psi	-30 inHg 40 psi	-10 inHg 4 psi	-100 kPa to 1100 kPa	-100 kPa 400 kPa	-50 kPa 40 kPa	-1 kg/cm ² to 11.2 kg/cm ²	-1 kg/cm ² 4 kg/cm ²	-0.5 kg/cm ² 0.4kg/cm ²	-1 bar to 11 bar	-1 bar 4 bar	-0.5 bar 0.4 bar
-30 inHg to 200 psi	-30 inHg 40 psi	-10 inHg 4 psi	-100 kPa to 1360 kPa	-100 kPa 400 kPa	-50 kPa 40 kPa	-1 kg/cm ² to 14 kg/cm ²	-1 kg/cm ² 4 kg/cm ²	-0.5 kg/cm ² 0.4 kg/cm ²	-1 bar to 13.6 bar	-1 bar 4 bar	-0.5 bar 0.4 bar
-30 inHg to 300 psi	-30 inHg 50 psi	-10 inHg 5 psi	-100 kPa to 2050 kPa	-100 kPa 500 kPa	-50 kPa 50 kPa	-1 kg/cm ² to 21 kg/cm ²	-1 kg/cm ² 5 kg/cm ²	-0.5 kg/cm ² 0.5 kg/cm ²	-1 bar to 20.5 bar	-1 bar 5 bar	-0.5 bar 0.5 bar
0 psi to 15 psi	3 psi	0.2 psi	0 kPa to 100 kPa	30 kPa	2 kPa	0 kg/cm ² to 1.05 kg/cm ²	0.3 kg/cm ²	0.02 kg/cm ²	0 bar to 1.00 bar	0.3 bar	0.02 bar
0 psi to 30 psi	5 psi	0.5 psi	0 kPa to 205 kPa	50 kPa	5 kPa	0 kg/cm ² to 2.1 kg/cm ²	0.5 kg/cm ²	0.05 kg/cm ²	0 bar to 2.05 bar	0.5 bar	0.05 bar
0 psi to 60 psi	10 psi	1 psi	0 kPa to 410 kPa	100 kPa	10 kPa	0 kg/cm ² to 4.2 kg/cm ²	1 kg/cm ²	0.01 kg/cm ²	0 bar to 4.10 bar	1 bar	0.1 bar
0 psi to 100 psi	20 psi	2psi	0 kPa to 680 kPa	200 kPa	20 kPa	0 kg/cm ² to 7 kg/cm ²	2 kg/cm ²	0.2 kg/cm ²	0 bar to 6.8 bar	2 bar	0.2bar
0 psi to 160 psi	40 psi	4 psi	0 kPa to 1100 kPa	400 kPa	40 kPa	0 kg/cm ² to 11.0 kg/cm ²	4 kg/cm ²	0.4kg/cm ²	0 bar to 11 bar	4 bar	0.4 bar
0 psi to 200 psi	40 psi	4 psi	0 kPa to 1360 kPa	400 kPa	40 kPa	0 kg/cm ² to 14 kg/cm ²	4 kg/cm ²	0.4 kg/cm ²	0 bar to 13.6 bar	4 bar	0.4 bar
0 psi to 300 psi	50 psi	5 psi	0 kPa to 2050 kPa	500 kPa	50 kPa	0 kg/cm ² to 21 kg/cm ²	5 kg/cm ²	0.5 kg/cm ²	0 bar to 20.5 bar	5 bar	0.5 bar
0 psi to 400 psi	100 psi	10 psi	0 kPa to 2700 kPa	1000 kPa	100 kPa	0 kg/cm ² to 28 kg/cm ²	2 kg/cm ²	0.5 kg/cm ²	0 bar to 27.0 bar	2 bar	0.5 bar
0 psi to 600 psi	100 psi	10 psi	0 kPa to 4100 kPa	1000 kPa	100 kPa	0 kg/cm ² to 42 kg/cm ²	10 kg/cm ²	1 kg/cm ²	0 bar to 41.0 bar	10 bar	1 bar
0 psi to 1000 psi	200 psi	20 psi	0 kPa to 6800 kPa	2000 kPa	200 kPa	0 kg/cm ² to 70 kg/cm ²	20 kg/cm ²	2 kg/cm ²	0 bar to 68 bar	20 bar	2 bar
0 psi to 1500 psi	300 psi	20 psi	0 kPa to 10000 kPa	3000 kPa	200 kPa	0 kg/cm ² to 105 kg/cm ²	30 kg/cm ²	2 kg/cm ²	0 bar to 100 bar	30 bar	2 bar
0 psi to 2000 psi	400 psi	40 psi	0 kPa to 13600 kPa	4000 kPa	400 kPa	0 kg/cm ² to 140 kg/cm ²	40 kg/cm ²	4 kg/cm ²	0 bar to 136 bar	40 bar	4 bar
0 psi to 3000 psi	500 psi	50 psi	0 kPa to 20500 kPa	5000 kPa	500 kPa	0 kg/cm ² to 210 kg/cm ²	50 kg/cm ²	5 kg/cm ²	0 bar to 205 bar	50 bar	5 bar
0 psi to 5000 psi	1000 psi	100 psi	0 kPa to 34000 kPa	10000 kPa	1000 kPa	0 kg/cm ² to 350 kg/cm ²	100 kg/cm ²	10 kg/cm ²	0 bar to 340 bar	100 bar	10 bar
0 psi to 6000 psi	1000 psi	100 psi	0 kPa to 41000 kPa	10000 kPa	1000 kPa	0 kg/cm ² to 420 kg/cm ²	100 kg/cm ²	10 kg/cm ²	0 bar to 410 bar	100 bar	10 bar
0 psi to 7500 psi	1500 psi	100 psi	0 kPa to 51000 kPa	10000 kPa	1000 kPa	0 kg/cm ² to 520 kg/cm ²	100 kg/cm ²	10 kg/cm ²	0 bar to 510 bar	100 bar	10 bar
0 psi to 10000 psi	2000 psi	200 psi	0 kPa to 68000 kPa	20000 kPa	2000 kPa	0 kg/cm ² to 700 kg/cm ²	200 kg/cm ²	20 kg/cm ²	0 bar to 680 bar	200 bar	20 bar
0 psi to 15000 psi	3000 psi	200 psi	0 kPa to 102000 kPa	30000 kPa	2000 kPa	0 kg/cm ² to 1040 kg/cm ²	300 kg/cm ²	20 kg/cm ²	0 bar to 1020 bar	300 bar	20 bar

Accuracy/Standard Dial Configuration

Applies to:

-600/700 Series Gauges: 4-1/2 inch

ACCURACY: ±0.5% Full Scale ASME Grade 2A											
Primary Scale				Secondary Scales							
Dial Range	Figure	Graduation	kPa	Figure	Graduation	kg/cm ²	Figure	Graduation	bar	Figure	Graduation
-30 inHg to 0 psi	-5 inHg	-0.2 inHg	-100 kPa to 0 kPa	-20 kPa	-1 kPa	-1 kg/cm ² to 0 kg/cm ²	-0.2 kg/cm ²	-0.01 kg/cm ²	-1 bar to 0 bar	-0.2 bar	-0.01 bar
-30 inHg to 15 psi	-5 inHg 3 psi	-0.5 inHg 0.2 psi	-100 kPa to 100 kPa	-20 kPa 20 kPa	-2 kPa 2 kPa	-1 kg/cm ² to 1.05 kg/cm ²	-0.2 kg/cm ² 0.2 kg/cm ²	-0.02 kg/cm ² 0.02 kg/cm ²	-1 bar to 1 bar	-0.2 bar 0.2 bar	-0.02 bar 0.02 bar
-30 inHg to 30 psi	-10 inHg 5 psi	-1 inHg 0.5 psi	-100 kPa to 205 kPa	-50 kPa 50 kPa	-5 kPa 5 kPa	-1 kg/cm ² to 2.10 kg/cm ²	-1 kg/cm ² 0.5 kg/cm ²	-0.1 kg/cm ² 0.05 kg/cm ²	-1 bar to 2.05 bar	-0.5 bar 0.5 bar	-0.05 bar 0.05 bar
-30 inHg to 60 psi	-10 inHg 10 psi	-1 inHg 0.4 psi	-100 kPa to 410 kPa	-50 kPa 100 kPa	-1 kPa 4 kPa	-1 kg/cm ² to 4.2 kg/cm ²	-0.5 kg/cm ² 1 kg/cm ²	-1 kg/cm ² 0.04 kg/cm ²	-1 bar to 4 bar	-0.5 bar 1 bar	-1 bar 0.04 bar
-30 inHg to 100 psi	-30 inHg 10 psi	-2 inHg 1 psi	-100 kPa to 680 kPa	-100 kPa 100 kPa	-10 kPa 10 kPa	-1 kg/cm ² to 7 kg/cm ²	-1 kg/cm ² 1 kg/cm ²	-0.1 kg/cm ² 0.1 kg/cm ²	-1 bar to 6.8 bar	-1 bar 1 bar	-0.1 bar 0.1 bar
-30 inHg to 160 psi	-30 inHg 20 psi	-5 inHg 2 psi	-100 kPa to 1100 kPa	-100 kPa 200 kPa	-20 kPa 20 kPa	-1 kg/cm ² to 11.2 kg/cm ²	-1 kg/cm ² 2 kg/cm ²	-0.2 kg/cm ² 0.2 kg/cm ²	-1 bar to 11 bar	-1 bar 2 bar	-0.2 bar 0.2 bar
-30 inHg to 200 psi	-30 inHg 20 psi	-5 inHg 2 psi	-100 kPa to 1360 kPa	-100 kPa 200 kPa	-20 kPa 20 kPa	-1 kg/cm ² to 14 kg/cm ²	-1 kg/cm ² 2 kg/cm ²	-0.2 kg/cm ² 0.2 kg/cm ²	-1 bar to 13.6 bar	-1 bar 2 bar	-0.2 bar 0.2 bar
0 psi to 15 psi	3 psi	0.1 psi	0 kPa to 100 kPa	30 kPa	1 kPa	0 kg/cm ² to 1.05 kg/cm ²	0.3 kg/cm ²	0.01 kg/cm ²	0 bar to 1.00 bar	0.3 bar	0.01 bar
0 psi to 30 psi	5 psi	0.2 psi	0 kPa to 205 kPa	50 kPa	2 kPa	0 kg/cm ² to 2.1 kg/cm ²	0.5 kg/cm ²	0.02 kg/cm ²	0 bar to 2.05 bar	0.5 bar	0.02 bar
0 psi to 60 psi	10 psi	0.4 psi	0 kPa to 410 kPa	100 kPa	4 kPa	0 kg/cm ² to 4.2 kg/cm ²	1 kg/cm ²	0.04 kg/cm ²	0 bar to 4.10 bar	1 bar	0.04 bar
0 psi to 100 psi	10 psi	1 psi	0 kPa to 680 kPa	100 kPa	10 kPa	0 kg/cm ² to 7 kg/cm ²	1 kg/cm ²	0.1 kg/cm ²	0 bar to 6.8 bar	1 bar	0.1 bar
0 psi to 160 psi	20 psi	1 psi	0 kPa to 1100 kPa	200 kPa	10 kPa	0 kg/cm ² to 11.0 kg/cm ²	2 kg/cm ²	0.1 kg/cm ²	0 bar to 11 bar	2 bar	0.1 bar
0 psi to 200 psi	20 psi	2 psi	0 kPa to 1360 kPa	200 kPa	20 kPa	0 kg/cm ² to 14 kg/cm ²	2 kg/cm ²	0.2 kg/cm ²	0 bar to 13.6 bar	2 bar	0.2 bar
0 psi to 300 psi	50 psi	2 psi	0 kPa to 2050 kPa	500 kPa	20 kPa	0 kg/cm ² to 21 kg/cm ²	5 kg/cm ²	0.2 kg/cm ²	0 bar to 20.5 bar	5 bar	0.2 bar
0 psi to 400 psi	40 psi	4 psi	0 kPa to 2700 kPa	400 kPa	40 kPa	0 kg/cm ² to 28 kg/cm ²	4 kg/cm ²	0.4 kg/cm ²	0 bar to 27.0 bar	4 bar	0.4 bar
0 psi to 600 psi	100 psi	4 psi	0 kPa to 4100 kPa	1000 kPa	40 kPa	0 kg/cm ² to 42 kg/cm ²	10 kg/cm ²	0.4 kg/cm ²	0 bar to 41.0 bar	10 bar	0.4 bar
0 psi to 1000 psi	100 psi	10 psi	0 kPa to 6800 kPa	1000 kPa	100 kPa	0 kg/cm ² to 70 kg/cm ²	10 kg/cm ²	1 kg/cm ²	0 bar to 68 bar	10 bar	1 bar
0 psi to 1500 psi	300 psi	10 psi	0 kPa to 10000 kPa	3000 kPa	100 kPa	0 kg/cm ² to 105 kg/cm ²	30 kg/cm ²	1 kg/cm ²	0 bar to 100 bar	30 bar	1 bar
0 psi to 2000 psi	200 psi	20 psi	0 kPa to 13600 kPa	2000 kPa	200 kPa	0 kg/cm ² to 140 kg/cm ²	20 kg/cm ²	2 kg/cm ²	0 bar to 136 bar	20 bar	2 bar
0 psi to 3000 psi	500 psi	20 psi	0 kPa to 20500 kPa	5000 kPa	200 kPa	0 kg/cm ² to 210 kg/cm ²	50 kg/cm ²	2 kg/cm ²	0 bar to 205 bar	50 bar	2 bar
0 psi to 5000 psi	500 psi	50 psi	0 kPa to 34000 kPa	5000 kPa	500 kPa	0 kg/cm ² to 350 kg/cm ²	50 kg/cm ²	5 kg/cm ²	0 bar to 340 bar	50 bar	5 bar
0 psi to 6000 psi	1000 psi	40 psi	0 kPa to 41000 kPa	10000 kPa	400 kPa	0 kg/cm ² to 420 kg/cm ²	100 kg/cm ²	4 kg/cm ²	0 bar to 410 bar	100 bar	4 bar
0 psi to 10000 psi	1000 psi	100 psi	0 kPa to 68000 kPa	10000 kPa	1000 kPa	0 kg/cm ² to 700 kg/cm ²	100 kg/cm ²	10 kg/cm ²	0 bar to 680 bar	100 bar	10 bar
0 psi to 15000 psi	3000 psi	100 psi	0 kPa to 103000 kPa	30000 kPa	1000 kPa	0 kg/cm ² to 1050 kg/cm ²	300 kg/cm ²	10 kg/cm ²	0 bar to 1030 bar	300 bar	10 bar
0 psi to 20000 psi	2000 psi	200 psi	0 kPa to 136000 kPa	20000 kPa	2000 kPa	0 kg/cm ² to 1400 kg/cm ²	200 kg/cm ²	20 kg/cm ²	0 bar to 1360 bar	200 bar	20 bar
0 psi to 30000 psi	5000 psi	200 psi	0 kPa to 205000 kPa	50000 kPa	2000 kPa	0 kg/cm ² to 2100 kg/cm ²	500 kg/cm ²	20 kg/cm ²	0 bar to 2050 bar	500 bar	20 bar
0 psi to 40000 psi	4000 psi	400 psi	0 kPa to 270000 kPa	40000 kPa	4000 kPa	0 kg/cm ² to 2800 kg/cm ²	400 kg/cm ²	40 kg/cm ²	0 bar to 2700 bar	400 bar	40 bar
0 psi to 50000 psi	5000 psi	500 psi	0 kPa to 340000 kPa	50000 kPa	5000 kPa	0 kg/cm ² to 3500 kg/cm ²	500 kg/cm ²	50 kg/cm ²	0 bar to 3400 bar	500 bar	50 bar
0 psi to 60000 psi	10000 psi	1000 psi	0 kPa to 410000 kPa	100000 kPa	10000 kPa	0 kg/cm ² to 4200 kg/cm ²	1000 kg/cm ²	40 kg/cm ²	0 bar to 4100 bar	1000 bar	40 bar

Accuracy/Standard Dial Configuration

Applies to:

100 Series Gauges: 1-1/2, 2 and 2-1/2 inch

400 Series Gauges: 1-1/2 inch

900 Series Gauges: 1-1/2, and 2 inch

ACCURACY: $\pm 2.5\%$ Full Scale ASME Grade 2A											
Primary Scale				Secondary Scales							
Dial Range	Figure	Graduation	kPa	Figure	Graduation	kg/cm ²	Figure	Graduation	bar	Figure	Graduation
-30 inHg to 0 psi	-5 inHg	-0.5 inHg	-100 kPa to 0 kPa	-20 kPa	-5 kPa	-1 kg/cm ² to 0 kg/cm ²	-0.2 kg/cm ²	-0.05 kg/cm ²	-1 bar to 0 bar	-0.2 bar	-0.05 bar
-30 inHg to 15 psi	-10 inHg 5 psi	-1 inHg 0.5 psi	-100 kPa to 100 kPa	-50 kPa 50 kPa	-5 kPa 5 kPa	-1 kg/cm ² to 1.05 kg/cm ²	-0.5 kg/cm ² 0.5 kg/cm ²	-0.05 kg/cm ² 0.05 kg/cm ²	-1 bar to 1 bar	-0.5 bar 0.5 bar	-0.05 bar 0.05 bar
-30 inHg to 30 psi	-30 inHg 10 psi	-2 inHg 1 psi	-100 kPa to 205 kPa	-100 kPa 100 kPa	-10 kPa 10 kPa	-1 kg/cm ² to 2.10 kg/cm ²	-1 kg/cm ² 1 kg/cm ²	-0.1 kg/cm ² 0.1 kg/cm ²	-1 bar to 2.05 bar	-1 bar 1 bar	-0.1 bar 0.1 bar
-30 inHg to 60 psi	-30 inHg 20 psi	-5 inHg 2 psi	-100 kPa to 410 kPa	-100 kPa 200 kPa	-20 kPa 20 kPa	-1 kg/cm ² to 4.2 kg/cm ²	-1 kg/cm ² 2 kg/cm ²	-2 kg/cm ² 0.2 kg/cm ²	-1 bar to 4 bar	-1 bar 2 bar	-0.2 bar 0.2 bar
-30 inHg to 100 psi	-30 inHg 20 psi	-10 inHg 5 psi	-100 kPa to 680 kPa	-100 kPa 200 kPa	-50 kPa 50 kPa	-1 kg/cm ² to 7 kg/cm ²	-1 kg/cm ² 2 kg/cm ²	-0.5 kg/cm ² 0.5 kg/cm ²	-1 bar to 6.8 bar	-1 bar 2 bar	-0.5 bar 0.5 bar
-30 inHg to 160 psi	-30 inHg 40 psi	-10 inHg 4 psi	-100 kPa to 1100 kPa	-100 kPa 400 kPa	-50 kPa 40 kPa	-1 kg/cm ² to 11.2 kg/cm ²	-1 kg/cm ² 4 kg/cm ²	-0.5 kg/cm ² 0.4 kg/cm ²	-1 bar to 11 bar	-1 bar 4 bar	-0.5 bar 0.4 bar
-30 inHg to 200 psi	-30 inHg 40 psi	-10 inHg 4 psi	-100 kPa to 1360 kPa	-100 kPa 400 kPa	-50 kPa 40 kPa	-1 kg/cm ² to 14 kg/cm ²	-1 kg/cm ² 4 kg/cm ²	-0.5 kg/cm ² 0.4 kg/cm ²	-1 bar to 13.6 bar	-1 bar 4 bar	-0.5 bar 0.4 bar
-30 inHg to 300 psi	-30 inHg 100 psi	-30 inHg 10 psi	-100 kPa to 2050 kPa	-100 kPa 1000 kPa	-100 kPa 100 kPa	-1 kg/cm ² to 21 kg/cm ²	-1 kg/cm ² 10 kg/cm ²	-1 kg/cm ² 1 kg/cm ²	-1 bar to 20.5 bar	-1 bar 10 bar	-0.1 bar 0.1 bar
0 psi to 15 psi	3 psi	0.5 psi	0 kPa to 100 kPa	30 kPa	5 kPa	0 kg/cm ² to 1.05 kg/cm ²	0.3 kg/cm ²	0.05 kg/cm ²	0 bar to 1.00 bar	0.3 bar	0.05 bar
0 psi to 30 psi	5 psi	0.5 psi	0 kPa to 205 kPa	50 kPa	5 kPa	0 kg/cm ² to 2.1 kg/cm ²	0.5 kg/cm ²	0.05 kg/cm ²	0 bar to 2.05 bar	0.5 bar	0.05 bar
0 psi to 60 psi	10 psi	1 psi	0 kPa to 410 kPa	100 kPa	10 kPa	0 kg/cm ² to 4.2 kg/cm ²	1 kg/cm ²	0.01 kg/cm ²	0 bar to 4.10 bar	1 bar	0.1 bar
0 psi to 100 psi	20 psi	2 psi	0 kPa to 680 kPa	200 kPa	20 kPa	0 kg/cm ² to 7 kg/cm ²	2 kg/cm ²	0.2 kg/cm ²	0 bar to 6.8 bar	2 bar	0.2 bar
0 psi to 160 psi	40 psi	4 psi	0 kPa to 1100 kPa	400 kPa	40 kPa	0 kg/cm ² to 11.0 kg/cm ²	4 kg/cm ²	0.4 kg/cm ²	0 bar to 11 bar	4 bar	0.4 bar
0 psi to 200 psi	40 psi	4 psi	0 kPa to 1360 kPa	400 kPa	40 kPa	0 kg/cm ² to 14 kg/cm ²	4 kg/cm ²	0.4 kg/cm ²	0 bar to 13.6 bar	4 bar	0.4 bar
0 psi to 300 psi	50 psi	5 psi	0 kPa to 2050 kPa	500 kPa	50 kPa	0 kg/cm ² to 21 kg/cm ²	5 kg/cm ²	0.5 kg/cm ²	0 bar to 20.5 bar	5 bar	0.5 bar
0 psi to 400 psi	100 psi	10 psi	0 kPa to 2700 kPa	1000 kPa	100 kPa	0 kg/cm ² to 28 kg/cm ²	2 kg/cm ²	0.5 kg/cm ²	0 bar to 27.0 bar	2 bar	0.5 bar
0 psi to 600 psi	100 psi	10 psi	0 kPa to 4100 kPa	1000 kPa	100 kPa	0 kg/cm ² to 42 kg/cm ²	10 kg/cm ²	1 kg/cm ²	0 bar to 41.0 bar	10 bar	1 bar
0 psi to 1000 psi	200 psi	20 psi	0 kPa to 6800 kPa	2000 kPa	200 kPa	0 kg/cm ² to 70 kg/cm ²	20 kg/cm ²	2 kg/cm ²	0 bar to 68 bar	20 bar	2 bar
0 psi to 1500 psi	300 psi	50 psi	0 kPa to 10000 kPa	3000 kPa	500 kPa	0 kg/cm ² to 105 kg/cm ²	30 kg/cm ²	5 kg/cm ²	0 bar to 100 bar	30 bar	5 bar
0 psi to 2000 psi	400 psi	40 psi	0 kPa to 13600 kPa	4000 kPa	400 kPa	0 kg/cm ² to 140 kg/cm ²	40 kg/cm ²	4 kg/cm ²	0 bar to 136 bar	40 bar	4 bar
0 psi to 3000 psi	500 psi	50 psi	0 kPa to 20500 kPa	5000 kPa	500 kPa	0 kg/cm ² to 210 kg/cm ²	50 kg/cm ²	5 kg/cm ²	0 bar to 205 bar	50 bar	5 bar
0 psi to 5000 psi	1000 psi	100 psi	0 kPa to 34000 kPa	10000 kPa	1000 kPa	0 kg/cm ² to 350 kg/cm ²	100 kg/cm ²	10 kg/cm ²	0 bar to 340 bar	100 bar	10 bar
0 psi to 6000 psi	1000 psi	100 psi	0 kPa to 41000 kPa	10000 kPa	1000 kPa	0 kg/cm ² to 420 kg/cm ²	100 kg/cm ²	10 kg/cm ²	0 bar to 410 bar	100 bar	10 bar

Accuracy/Standard Dial Configuration

Applies to:
800 Series Gauges

ACCURACY: ±0.25% Full Scale ASME Grade 3A					
Primary Scale			Primary Scale		
Dial Range	Figure	Graduation	Dial Range	Figure	Graduation
0 psi to 30 psi	2 psi	0.1 psi	0 psi to 1500 psi	100 psi	5 psi
0 psi to 60 psi	5 psi	0.2 psi	0 psi to 2000 psi	200 psi	10 psi
0 psi to 100 psi	10 psi	0.5 psi	0 psi to 3000 psi	250 psi	10 psi
0 psi to 160 psi	20 psi	0.8 psi	0 psi to 5000 psi	500 psi	20 psi
0 psi to 200 psi	20 psi	1 psi	0 psi to 6000 psi	500 psi	20 psi
0 psi to 300 psi	25 psi	1 psi	0 psi to 10000 psi	1000 psi	50 psi
0 psi to 400 psi	50 psi	2 psi	0 psi to 15000 psi	1000 psi	50 psi
0 psi to 600 psi	50 psi	2 psi	0 psi to 20000 psi	2000 psi	100 psi
0 psi to 1000 psi	100 psi	5 psi			

PRESSURE & VACUUM CONVERSIONS

Lbs. per Sq. in.	bar	Kilopascals	Kilograms per Sq. cm	Ounces per Sq. in	Inches of Mercury	Millimeters of Mercury	Inches of Water
psi	bar	kPa	kg/cm ²	oz-in ²	inHg	mmHg*	inH ₂ O
1	.0689476	6.89476	.0703069	16	2.03602	51.71485	27.6807
14.5038	1	100	1.019716	232.0608	29.530	750.0626	401.8596
.145038	.01	1	.0101972	2.320608	.295299	7.500610	401.8596
14.2233	.9806649	98.06649	1	227.5739	28.95901	735.5588	393.7118
.0625	.0043092	.4309223	.0043942	1	.1272513	3.23218	1.73004
.4911542	.0338639	3.386389	.0345316	7.85847	1	25.4	13.59548
.0193368	.0013332	.1333225	.0013595	.3093888	.0393701	1	.535255
.0361263	.0024908	.2490819	.0025422	.578020	.0735539	1.868268	1

* 1 kPa = 1 kN/m², 1 mmHg = 1 Torr, 1Kg/cm² = 1 kp/cm²
(Conversions of: H₂O are at 39.2°F (4°C); Hg are at 32°F (0°C))

CONVERSIONS FOR HYDRAULIC RAM CAPACITY

$$\text{psi} \times \text{AREA} = (\text{LBS.}) \text{ FORCE} \qquad \text{TONS} = \frac{\text{psi} \times .7854 \times D^2}{2000} \qquad \text{psi} = \frac{\text{TONS}}{D^2 \times .0003927}$$

For further assistance with conversions please consult the factory.

Gauge Configurations for High Temperature Applications

140° F is the maximum recommended ambient media temperature for NOSHOK pressure gauges with brass wetted parts, and 212° F for gauges with stainless steel wetted parts. For applications in which media reaches temperatures above 212° F, NOSHOK offers several accessories designed to prevent damage to the gauge, and maintain maximum performance and accuracy.

Recommended gauge configurations are listed below. Please note that these guidelines are intended to be general recommendations. Many conditions may affect the amount of temperature reduction; including ambient temperature, media type, and process configuration.

- **Up to 140° F:** All NOSHOK pressure gauges will provide peak performance in this range
- **Up to 212° F:** A gauge with stainless steel wetted parts is required, such as the NOSHOK 400 and 740 Series. Do NOT use a gauge with brass wetted parts.
- **Up to 287° F:** Accessories must be used to maintain gauge integrity and accuracy. Options include:
 - o **Pigtail Steam Syphon:** for use with a stainless steel wetted parts gauge. Should be used in steam applications and systems that contain superheated vapor. The pigtail buffers the instrument from the damaging effects of high temperature steam by holding system fluid in the coil to provide a steam trap for the fluid to condensate and dissipate the heat. Reduces temperature by 75° F/ft on average. Multiple configurations are available.
 - o **Armored Capillary Tube:** for use with a stainless steel wetted parts gauge. Average temperature reduction is 75° F/ft. Two feet of capillary tube can increase the media temperature range to 362° F. Standard length is five feet, provided with thread connections; other lengths available on request. Gauge must be separated from the process with a mounting bracket or flange, and the extra capillary length can be rolled up if necessary. Recommended for use with clean media or gases.
 - o **Long Pipe:** 1/2" in diameter or greater in either steel or stainless steel construction with a stainless steel wetted parts gauge. Average temperature reduction is 75° F/ft. Pipes can be cut and threaded for custom applications.
 - o **Cooling Element:** for use with a stainless steel wetted parts gauge. Average temperature reduction is 75° F/4" element. Use with other accessories for additional temperature decrease (long pipe, syphon, diaphragm seal).
 - o **Cooling Tower:** for use with a stainless steel wetted parts gauge. Approved usage up to temperatures of 312° F. Average temperature reduction is 100° F/8" cooling tower. Recommended for use with clean media or gases.
- **Up to 300° F:** A high temperature system fill is required, such as silicone D.C 550, and a diaphragm seal is recommended on a stainless steel wetted parts gauge.

For more information, contact NOSHOK at 440.243.0888

Three Process Conditions That Affect Accuracy And Performance Of Pressure Gauges And Solutions To Manage Them

The technology used in today's pressure gauges has been around since the mid-eighteen hundreds, and the pressure gauge is still one of the most common methods of measuring pressure today. The majority of pressure gauges today still incorporate the bourdon tube, socket, and geared movement; along with a pointer and dial to indicate process pressure.

Since the pressure gauge is a purely mechanical device, attention to three process conditions is necessary. The three factors that can adversely affect accuracy and performance are **Temperature, Vibration and Pulsation**.

Temperature Influence:

For every 100° shift in temperature from which the gauge is calibrated, the user can experience up to a 2% additional error in reading. The cause is the change in the elasticity or spring rate of the bourdon tube element with temperature. While it is difficult to circumvent the influence of ambient temperature, we can address the influence of process temperature. In steam service, the common practice is to install coil syphons or pigtail syphons to dissipate process heat. Another common practice is to install a diaphragm seal with capillary to separate the gauge from the high heat source. There are many options available with fill fluid in the seal and capillary system to withstand temperatures up to 600° F. In severe cold ambient conditions, many users elect to heat trace their instrumentation via electric or steam trace. Process and ambient temperature is an important consideration when selecting and applying pressure gauges.

Vibration Influence:

Vibration due to pumps, motors, and other rotating equipment can cause excess wear and possible premature failure of internal working parts of a pressure gauge, which include the bourdon tube and the movement or gear mechanism. Vibration also causes difficulty in accurate reading of the gauge, due to pointer oscillation. One of the most common causes of pressure gauge failure is exposure to continuous vibration. The most widely accepted remedy is to utilize a liquid filled pressure gauge. The fill fluid of choice is either glycerine or silicone. Liquid filled gauges address not only pointer oscillation, but also serve to protect and lubricate the internal geared movement.

Pulsation Influence:

Process pulsation can occur around the discharge of pumps as well as quick operating valves. Many users assume that liquid filling a pressure gauge will fully address pulsation. Although a liquid filled gauge helps to dampen the effects of pulsation, it often does not fully address this process condition. Pulsation dampeners are installed upstream of the gauge socket and they can be a piston-type snubber, a sintered metal snubber, or a threaded in-flow restrictor in the socket of the gauge. A needle valve installed upstream of the gauge that is "pinched down" or slightly opened, is another common practice to address pulsation. It is not recommended to rely solely on a needle valve to address pulsation, due to the fact that the user could inadvertently open the valve, and thereby negate flow restriction. In clean fluids (gases or clean low viscosity liquids) a threaded orifice/flow restrictor or a sintered metal snubber is the least costly way to address pulsation. In dirtier and higher viscosity fluids a piston snubber is usually installed.

Summary:

Temperature, vibration and pulsation are three process conditions that adversely affect a pressure gauge. Being aware of these three process conditions, and taking the necessary steps to address them, can help minimize accuracy errors and add to the service life of the pressure gauge.

Frequently Asked Questions

Q: What is the purpose of the ventable & non-ventable fill plug/relief plug?

A: A fill plug seals the fill hole in a pressure gauge case. On liquid filled pressure gauges, a ventable fill plug is used to relieve internal case pressures that occur due to thermal expansion of the fill fluid. In non-filled dry gauges, a non-ventable fill plug is used to occasionally drain the interior of the case from condensate or relieve internal case pressures. Ventable fill plugs incorporate a vent pin to open and close a hole for relieving internal case pressures and do not have to be removed from the case hole like non-ventable fill plugs.

Q: What are the designed overpressure ratings for NOSHOK gauges?

A: Overpressure ratings are specific to the gauge type, pressure range and accuracy ratings of the gauge. Normal overpressure protection can range from 1.1X to 1.3X depending on the gauge selected. NOSHOK gauges comply to the EN-837-1 and ASME B40-100 standards in regards to overpressure protection. When selecting a pressure gauge, it is recommended that the normal system pressure be maintained around half of the full range of the gauge as to avoid overpressure conditions.

Q: How is the accuracy of a gauge affected by a Maximum Indicating Pointer?

A: A Maximum Indicating Pointer (MIP), also commonly referred to as a Tell Tale Pointer, adds an additional $\pm 1\%$ error to the pressure gauge due to the increase load on the bourdon tube.

Q: What is a Certified Calibration?

A: Certified Calibrations provide the user with a serial numbered gauge along with a calibration certificate that it has been certified in accordance to the pressure gauge standard with instruments that are traceable to NIST with accuracies of at least 4 to 1.

Q: What is a Certificate of Conformance?

A: A Certificate of Conformance is a formal statement on company letterhead stating that an instrument complies with a particular standard. It contains the signatures of the required personnel. These Certificates are often needed to show industry inspectors that a system and its components are in compliance.

Q: How often does a gauge need to be calibrated?

A: NOSHOK pressure gauges require little or no calibration within the Warranty period. Some applications may be more aggressive than others, resulting in an increased frequency in the need for calibration. The environmental limitations for the pressure gauge series should be observed in all cases. Gauges used in situations outside these requirements may result in inaccuracies, premature wear and/or failure of the gauge and would require additional maintenance. The frequency of calibration, therefore, is up to the user to judge.

Q: When is it recommended to use an orifice?

A: Orifices are a type of snubber. On pressure systems that have rapidly increasing or decreasing pressure spikes, orifices lessen the effects of these energy pulses by blocking the wave energy using restricted flow. They are recommended in dynamic pressure applications with mild pressure spikes.

Q: When is a diaphragm seal used, and when would you apply a diaphragm seal and capillary?

A: A diaphragm is used to isolate and protect the instrument from the process media. Damaging process media may include corrosives, particulates, temperatures, or any state that is not suitable for direct contact with the measuring element. Diaphragms indirectly transmit system pressures by segregating the process pressure with a thin flexible membrane that in turn transfers the pressure through a fill fluid to the instrument. Diaphragms are often used in conjunction with capillaries to further distance the instrument from the process media. Capillary tubes transmit the diaphragm fill fluid to the instrument. Capillary tubes come in several lengths and provide the user a means to measure in a remote location and may also act as heat dissipaters in high temperature applications.

Q: What is the purpose of liquid filling a gauge, and in what applications would a liquid filled gauge be used?

A: Primarily, in applications that have vibrations or pulsations, liquid filling enables reading the dial pointer by dampening the movement. Liquid filling should be considered in any system that has high dynamic operating conditions. In general, liquid filling helps extend the life of a gauge. It reduces damaging resonance induced fracturing, reduces frictional wear, prevents aggressive ambient air from entering, prevents condensation formation, and improves reliability.

Q: How does temperature affect the accuracy of a pressure gauge?

A: Temperature changes affect the stiffness of a bourdon tube. The stiffness change is produced by a combination of changes in the elastic (Young's) modulus and a change in linear dimensions due to linear expansion and contraction. The error caused by temperature change will follow the approximate formula: $\pm 0.04 \times (t_2 - t_1)$ % of the span.

Q: How do you size a pressure gauge relative to process pressures, normal operating pressures, and maximum pressures in the process? (Dynamic or static process pressures)

A: The pressure range of a gauge should be 10% over the maximum working pressure in static conditions (no pressure fluctuations). In dynamic conditions, the gauge range should be 40% over the maximum working pressure. Ideally, the pressure gauge range should be selected for a midscale reading during normal operating pressures.

Q: What does a gauge accuracy statement really mean?

(Examples: 1% of span, 3-2-3 percent of span)

A: Accuracy is the conformity of a gauge indication to an accepted standard or true value. Accuracy is the difference between the true value and the gauge indication expressed as a percent of the gauge span. It is the combined effects of method, observer, apparatus, and environment. Accuracy error includes hysteresis and repeatability errors. An ASME B40.1 class B gauge has three accuracies. A 3-2-3 percent of span designation stands for 3% in the first quarter of the scale, 2% in the middle half of the scale and 3% in the upper quarter of the scale.

Q: What applications require the various lens materials, and to what maximum temperature can each be subjected?

A: Lens materials include Instrument Glass, Laminated Safety Glass, Tempered Glass, and plastic. Glass lenses are used for abrasion, chemical and wear resistant properties. Laminated safety glass reduces the possibility of shattering if the bourdon tube ruptures. Tempered glass is 2 to 5 times stronger than plain glass. Plastic lenses are used for impact, corrosion and chemical resistance. Special attention should be paid to the temperature and corrosive environments. Polycarbonate is selected for its superior impact resistance, Plexiglass™ for its clarity and scratch resistance and Homalite for its superior chemical resistance. In general, gauges with plastic lenses should remain below 140° F.

Q: In what situation would a pigtail syphon be used?

A: Pigtail syphons should be used in steam applications and systems that contain superheated vapor. The pigtail buffers the instrument from the damaging effects of high temperature steam by holding system fluid in the coil to provide a steam trap for the fluid to condensate and dissipate the heat.

Q: What is the application for a gauge cleaned for O2 service?

A: Oxygen (O₂) cleaning is performed on gauges that are used on oxygen service applications. The cleaning removes all hydrocarbons (oil and grease are common hydrocarbons) that can react violently, resulting in explosions, fire, and injury to personnel and property. Oxygen clean gauges can be used in any application that requires the cleanliness level associated with oxygen clean gauge. Glycerine fill gauge cannot be used on oxygen systems.

Q: What fill fluids options are available, and in what applications would each be used?

A: Glycerine is the most common fill fluid. Because of its unique fluid properties, Glycerine has become the standard for liquid filled gauges (see "What is the purpose of liquid filling a gauge?"). Glycerine's clarity, viscosity, stability, cost, solubility, low toxicity make Glycerine an ideal fluid for many applications. Mineral oils and silicon fluids are used when temperature extremes, chemical compatibility or viscosity fall outside of Glycerine use. Halocarbon is an inert fluid that is compatible with chlorine, oxygen service, and some high temperature applications. Keep in mind that Glycerine is not compatible with strong oxidizers such as oxygen, chlorine, hydrogen peroxide, or nitric acid. Glycerine & Silicon are explosive in contact with chlorine. Halocarbon is explosive in contact with aluminum and magnesium.

Q: What is the difference between ANSI vs. DIN specification, and which applies to specific gauges?

A: ANSI is the official U.S. representative to the International Organization for Standardization (ISO) and, via the U.S. National Committee, the International Electrotechnical Commission (IEC). ANSI is also a member of the International Accreditation Forum (IAF) for the American National Standards Institute. It approves American National Standards which include ASME B40-100. DIN stands for Deutsches Institut für Normung e.V. (DIN; in English is the German Institute for Standardization) is the German national organization for standardization and is that country's (ISO) member body. Many of the DIN standards have been converted to ISO standards.

Q: What is the purpose of throttle devices such as throttle plugs and screws?

A: Throttle devices limit the flow to the pressure instrument. They are a type of snubber.

Q: What is the purpose of an over and under load stop in a pressure gauge?

A: The tip motion of a bourdon tube is translated to rotary motion of a pointer by a linkage and sector gear acting on the pointer pinion gear. Stop pins limit the movement of the bourdon tube, sector or pointer rotation in over and under pressure conditions that would otherwise move the pointer pinion off the sector gear which would damage the gauge.

NOTES

A page of lined paper with a large, faint, stylized graphic in the background. The graphic consists of several overlapping geometric shapes: a large circle on the right, a vertical rectangle in the center, and several diagonal lines forming a larger, abstract shape on the left. The lines are light gray and the graphic is a medium gray color.

TO DOWNLOAD OR ORDER OUR CATALOGS,
VISIT WWW.NOSHOK.COM

Quality Policy

NOSHOK is
committed to providing
a high degree of value and continually
improving processes to improve customer
satisfaction by focusing on customer
requirements for the design, manufacture
and distribution of pressure, temperature,
and force measurement instruments
along with needle and
manifold valves.

All from world class technology.

Combined with real-world stamina.

The highest value with the industry's best warranty.

And all from a company with a 40+ year record of customer satisfaction.

All from your Single Source Instrumentation Company.



Corporate Headquarters

1010 West Bagley Road
Berea, Ohio 44017
Ph: 440.243.0888
Fax: 440.243.3472
E-mail: noshok@noshok.com
Web: www.noshok.com



Diaphragm Seal Solutions



Replaceable
Bolted
Flow-Through Annular Style

Non-Replaceable
Non-Metallic
Sanitary
Front Flush
Bolted

Accessories



At NOSHOK, we pride ourselves on being innovators in the industry by continually offering the latest technology and measurement solutions, and providing the best customer support in the marketplace.

Established in 1967, NOSHOK was one of the first companies to offer liquid filled pressure gauges. We also took a bold step by backing our quality gauges with an extended 3-year warranty. That unwavering standard of quality has endured for over 45 years, and as we have expanded our product offering we continue to provide industry-leading warranties. NOSHOK also leads the industry as one of the first companies to offer corrosion-resistant zinc nickel plating standard on our carbon steel valves.

We have the capacity to put together special requirements which are so often hard to find. If you do not find what you need in this catalog, chances are we can still put a solution together.

NOSHOK is committed to providing excellence on every level. Thank you for choosing NOSHOK products.

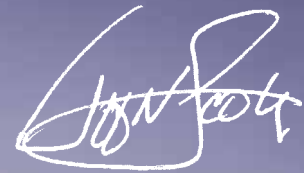

Jeff N. Scott
President



NOSHOK Corporate Headquarters
Your Single Source Instrumentation Company

NOSHOK is a member and actively supports:



NOSHOK is an ISO 9001:2008 registered company.

WARRANTY INFORMATION

NOSHOK's **One Year Warranty** applies to all NOSHOK diaphragm seals, and all options & accessories listed in this catalog.

NOSHOK guarantees all products to be free from defects in material and workmanship and to operate within the catalogued performance specifications. These products must be operated within the catalogued environmental and application parameters. Determination of failure will be made by NOSHOK, Inc.'s equipment and personnel or a certified test facility specializing in this type of evaluation. Diaphragm seal failures determined to be caused by over-range, incompatibility with environment or product media and abuse will not be considered under this warranty. NOSHOK, Inc. will, at its discretion, repair or replace the working parts of the damaged diaphragm seal without cost to the customer.

T A B L E O F C O N T E N T S



REPLACEABLE DIAPHRAGM

Standard & Elevated Pressure, Bolted:

TYPE 10/10H 4-5

Reduced Pressure, Non-Metallic Lower, Bolted:

TYPE 10L 6-7

Flow-Through Annular Style:

TYPE 40 8-9

NON-REPLACEABLE DIAPHRAGM

All Non-Metallic:

TYPE 5 10-11

Sanitary, Clamped-Style, ASME-BPE:

TYPE 12 12-13

Front Flush:

TYPE 20 14-15

Standard & Elevated Pressure:

TYPE 25/25H 16-17

High Volumetric Displacement:

TYPE 29 18-19

Standard & Elevated Pressure, Bolted:

TYPE 30/30H 20-21

Reduced Pressure, Non-Metallic Lower, Bolted:

TYPE 30L 22-23

ACCESSORIES

Plain and Armored Capillaries, Cooling Element, Sanitary Clamps and Gaskets 24

Reference Information 25-26

Standard & Elevated Pressure, Bolted

TYPE 10/10H



- Designed to isolate the pressure measuring instrument from high temperatures, or corrosive or viscous process media
- Can be used for remote mounting of pressure instrument(s) with capillary
- Utilizes a replaceable diaphragm clamped between the flanged metal housings with an o-ring seal to create a leak-free union
- Process connection sizes from 1/4" NPT through 1-1/2" NPT
- Flushing port connection is an available option that allows the wetted areas of the seal to be cleaned, or the process vented without removing the unit from the line
- Consider instrument size, pressure range, media composition, ambient and operating temperature, and maximum working pressure when selecting
- Capillaries and cooling elements are available for elevated process temperatures, see page 24
- Fill fluid must be compatible with process media; i.e. Glycerin may become volatile in conjunction with a strong oxidizing agent such as chlorine, forms of oxygen or peroxide and nitric acids

APPLICATIONS

- Water and wastewater
- Oil and gas
- Petrochemical
- Chemical processing
- Industrial automation
- Marine
- Agriculture
- Steel fabrication
- Mud pumping
- Pulp and paper
- Pneumatic

SPECIFICATIONS

Seal type	Threaded with replaceable diaphragm. Flanged available on request.			
Instruments	Type	Size	Minimum Pressure	Maximum Pressure
	Gauges	2-1/2" to 6"	0 psig to 30 psig	0 psig to 2,000 psig (10H - 5,000 psig)
	Transducers	-	0 psig to 30 psig	0 psig to 2,000 psig (10H - 5,000 psig)
	Switches	-	0 psig to 30 psig	0 psig to 2,000 psig (10H - 5,000 psig)
Upper housing	Type	Non-continuous duty (10H continuous duty)		
	Connections	1/4" NPT, 1/2" NPT		
	Materials	Polyurethane enamel coated steel, 316 Stainless steel		
Diaphragm	Size	3.0" (Type 10), 2-1/2" (Type 10H)		
	Displacement	3.2 ml (Type 10), 1.4 ml (Type 10H)		
	Materials	316 Stainless steel (Exotic materials available on request)		
O-rings	NBR, PTFE and FKM			
Lower housing	Connections	1/4" NPT, 1/2" NPT, 3/4" NPT, 1" NPT, 1-1/4" NPT, 1-1/2" NPT ASME flanges available on request		
	Materials	Polyurethane enamel coated steel and 316 Stainless steel (Exotic materials available on request)		
	Flushing port	Optional 1/8" NPT, 1/4" NPT and dual ports		
Bolting	Zinc-plated steel, optional Stainless steel			
Operating temperature	Operating temperature is determined by the temperature/pressure configuration. See the Material temperature table.			

ORDERING INFORMATION				
TYPES	10 (2,000 psi)	10H (5,000 psi)		
INSTRUMENT CONNECTION SIZES	02 1/4" NPT	04 1/2" NPT		
UPPER HOUSING MATERIALS	C Carbon steel	S 316 Stainless steel		
DIAPHRAGM MATERIALS	A Tantalum	M Monel 400	S 316 Stainless steel ²	U Titanium Grade 4
	H Hastelloy C – 276	N Inconel 600	T PTFE ^{1 4}	V FKM ^{1 3}
O-RING MATERIALS	B NBR	T PTFE ¹	V FKM	
PROCESS CONNECTION SIZES	02 1/4" NPT	06 3/4" NPT	10 1-1/4" NPT	
	04 1/2" NPT	08 1" NPT	12 1-1/2" NPT	
(ASME and DIN flanges available upon request)				
LOWER HOUSING MATERIALS	C Carbon steel	M Monel 400	S 316 Stainless steel	
	H Hastelloy C-276	N Inconel 600	U Titanium	
FLUSHING CONNECTIONS	1F 1/8" NPT	2F 1/4" NPT		

Please consult your local NOSHOK Distributor or NOSHOK, Inc. for availability and delivery information.

¹ Not available with 10H

² NBR o-rings standard with 316SS diaphragm

³ FKM o-rings standard with FKM diaphragm

⁴ PTFE o-rings standard with all other diaphragms

EXAMPLE

Type10
 Instrument connection size 1/4" NPT
 Upper housing material316 Stainless steel
 Diaphragm material316 Stainless steel
 O-ring materialNBR
 Process connection size 1/2" NPT
 Lower housing material316 Stainless steel
 Flushing connection (optional) 1/8" NPT

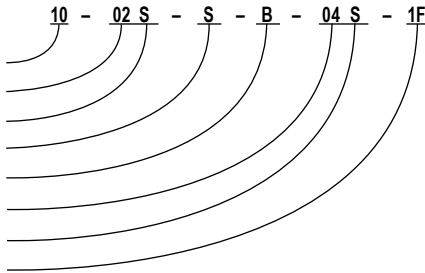

Type 10 Standard Pressure

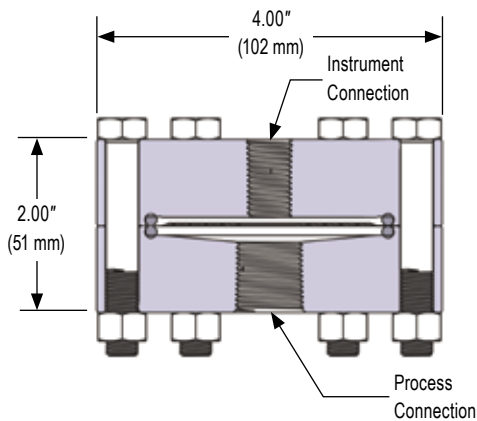

Type 10H Elevated Pressure

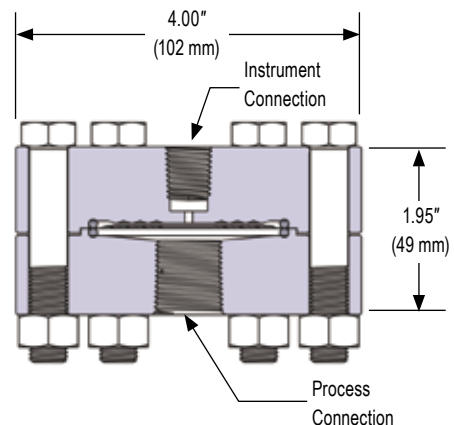

Reduced Pressure, Non-Metallic Lower, Bolted

TYPE 10L



- Intended for corrosive or viscous pressure media
- Designed for applications where typical metallic lower housings cannot withstand process media
- Can be used for remote mounting of pressure instrument(s) with capillary
- Utilizes a replaceable diaphragm clamped between the flanged housings with an o-ring seal to create a leak-free union
- Process connection sizes from 1/4" NPT through 1-1/2" NPT
- Consider instrument size, pressure range, media composition, ambient and operating temperature, and maximum working pressure when selecting
- Fill fluid must be compatible with process media; i.e. Glycerin may become volatile in conjunction with a strong oxidizing agent such as chlorine, forms of oxygen or peroxide and nitric acids

APPLICATIONS

- Water and wastewater
- Oil and gas
- Petrochemical
- Chemical processing
- Industrial automation
- Marine
- Agriculture
- Steel fabrication
- Mud pumping
- Pulp and paper
- Pneumatic

SPECIFICATIONS

Seal type	Threaded with replaceable diaphragm. Flanged available on request.			
Instruments	Type	Size	Minimum Pressure	Maximum Pressure
	Gauges	2-1/2" to 6"	0 psig to 30 psig	0 psig to 200 psig
	Transducers	-	0 psig to 30 psig	0 psig to 200 psig
	Switches	-	0 psig to 30 psig	0 psig to 200 psig
Upper housing	Type	Non-continuous duty		
	Connections	1/4" NPT, 1/2" NPT		
	Materials	Polyurethane enamel coated steel, 316 Stainless steel		
Diaphragm	Size	3.0"		
	Displacement	3.2 ml		
	Materials	316 Stainless steel, FKM, PTFE (Exotic materials available on request)		
O-rings	NBR, PTFE and FKM			
Lower housing	Connections	1/4" NPT, 1/2" NPT, 3/4" NPT, 1" NPT, 1-1/4" NPT, 1-1/2" NPT		
	Materials	PVDF, PP, PVC, PTFE (Other materials available on request)		
Bolting	Zinc-plated steel, optional stainless steel			
Operating temperature	Operating temperature is determined by the temperature/pressure configuration. See Material Temperature table.			

ORDERING INFORMATION				
TYPE	10L			
INSTRUMENT CONNECTION SIZES	02 1/4" NPT	04 1/2" NPT		
UPPER HOUSING MATERIALS	C Carbon steel	S 316 Stainless steel		
DIAPHRAGM MATERIALS	A Tantalum	M Monel 400	S 316 Stainless steel ¹	U Titanium Grade 4
	H Hastelloy C - 276	N Inconel 600	T PTFE ³	V FKM ²
O-RING MATERIALS	B NBR	T PTFE	V FKM	
PROCESS CONNECTION SIZES	02 1/4" NPT	06 3/4" NPT	10 1-1/4" NPT	12 1-1/2" NPT
	04 1/2" NPT	08 1" NPT		
	(ASME and DIN flanges available upon request)			
LOWER HOUSING MATERIALS	KN PVDF	PV PVC	TG PTFE (Glass filled)	
	PP PP	TC PTFE (Carbon filled)		

Please consult your local NOSHOK Distributor or NOSHOK, Inc. for availability and delivery information.

¹ NBR o-rings standard with 316SS diaphragm
² FKM o-rings standard with FKM diaphragm
³ PTFE o-rings standard with all other diaphragms

EXAMPLE

10L - 02 S - T - T - 04 PP

Type 10L
 Instrument connection size 1/4" NPT
 Upper housing material 316 Stainless steel
 Diaphragm material PTFE
 O-ring material PTFE
 Process connection size 1/2" NPT
 Lower housing material PP

Type 10L PTFE (Carbon & Glass Filled) **Type 10L PVC / PP / PVDF**

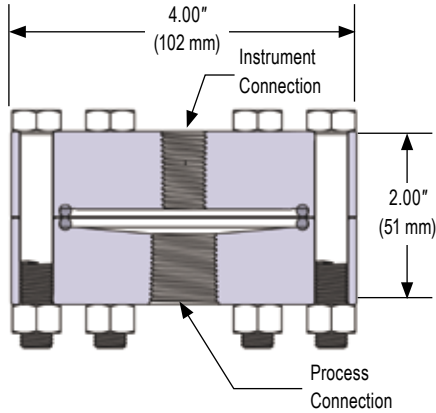
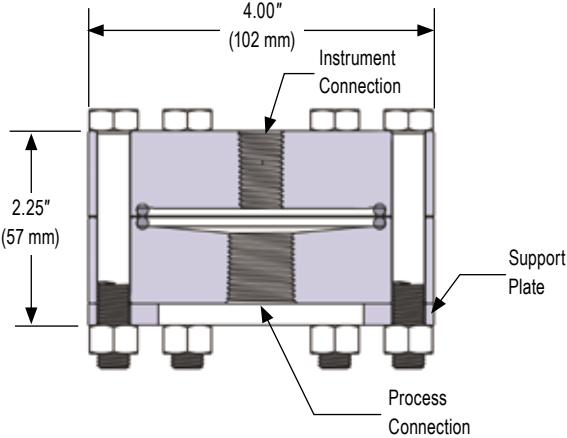

Flow-Through Annular Style



TYPE 40

- Process liquid flowing through the pipe exerts pressure onto a flush-mounted flexible inner cylinder containing clean, captive liquid; completely isolating instrumentation from the process flow and preventing plugging
- Can be used for remote mounting of pressure instrument(s) with capillary
- Instrumentation can be removed for calibration, repair or replacement without interrupting the process flow
- Integral design prevents accidental breakage
- Can be used with a variety of process conditions in many applications
- Eliminates clogging typically associated with diaphragm seals used in viscous fluid applications which can lead to inaccurate pressure readings
- Assembly flanges ASME B16.1 Class 150, 2" to 20"

APPLICATIONS

- Slurries
- Heavy sludges
- Chemical - synthetic polymers
- Diffusers - flow measurement
- Abrasive media

SPECIFICATIONS

SPECIFICATIONS				
Seal type	Inline flanged with sleeve diaphragm			
Instruments	Type	Size	Minimum Pressure	Maximum Pressure
	Gauges	2-1/2" to 6"	0 psig to 30 psig	0 psig to 285 psig
	Transducers	-	0 psig to 30 psig	0 psig to 285 psig
	Switches	-	0 psig to 30 psig	0 psig to 285 psig
Upper housing	Type	Non-continuous duty		
	Connections	1/4" NPT, 1/2" NPT		
	Materials	Polyurethane enamel coated steel, 316 Stainless steel		
Diaphragm	Size	Sleeve style per ring size		
	Materials	NBR, FKM, EPDM, PTFE (Other materials available on request)		
Flange Materials	Connections	Flanged, Class 150, 2" through 20"		
	Materials	Polyurethane enamel coated steel, 316 Stainless steel		
Bolting	Zinc-plated steel, optional stainless steel			
Operating temperature	-30 °F to 140 °F, based on materials of construction and fill fluid			

ORDERING INFORMATION				
TYPE	40 Annular Ring	40BT Bolt-Through Annular Ring		
INSTRUMENT CONNECTION SIZES	02 1/4" NPT	04 1/2" NPT		
HOUSING MATERIALS	C Carbon steel	S 316 Stainless steel		
DIAPHRAGM MATERIALS	B NBR	V FKM	T PTFE	E EPDM
PIPE SIZES	16 2" Pipe	40 5" Pipe	80 10" Pipe	128 16" Pipe
	24 3" Pipe	48 6" Pipe	96 12" Pipe	144 18" Pipe
	32 4" Pipe	64 8" Pipe	112 14" Pipe	160 20" Pipe
FLANGE MATERIALS	C Carbon steel	S 316 Stainless steel		

Please consult your local NOSHOK Distributor or NOSHOK, Inc. for availability and delivery information.

EXAMPLE

Type40
 Instrument connection size1/4" NPT
 Housing material Carbon steel
 Diaphragm material NBR
 Pipe size2" pipe
 Flange material Carbon steel

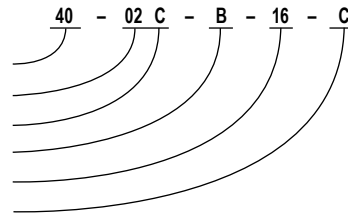

Type 40

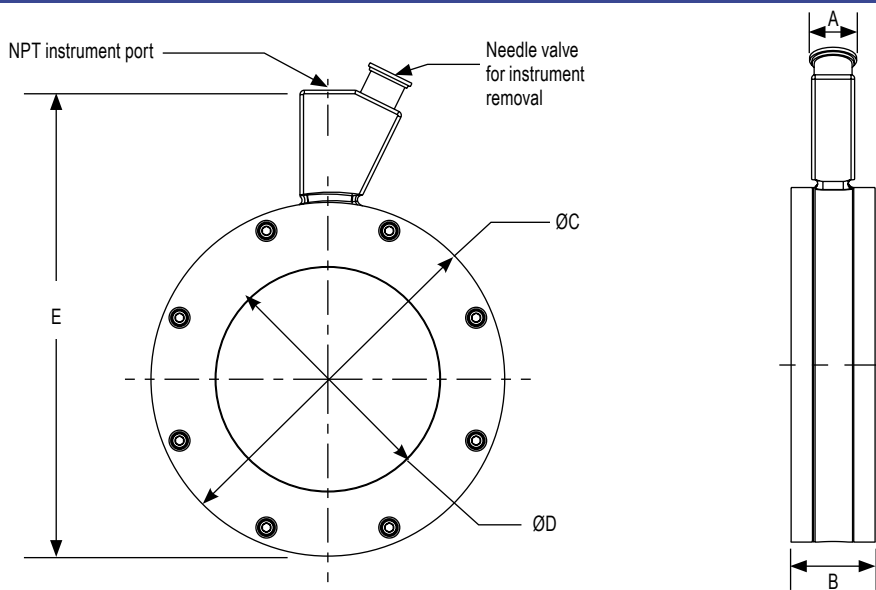

NOMINAL PIPE SIZE											
	2"	3"	4"	5"	6"	8"	10"	12"	14"	16"	18"
A	0.76" (19 mm)	0.76" (19 mm)	0.76" (19 mm)	0.76" (19 mm)	0.76" (19 mm)	0.76" (19 mm)	0.76" (19 mm)	0.76" (19 mm)	0.76" (19 mm)	0.76" (19 mm)	0.76" (19 mm)
B	2" (51 mm)	2" (51 mm)	1-1/2" (38 mm)	1-1/2" (38 mm)	1-1/2" (38 mm)	1-1/2" (38 mm)	1-1/2" (38 mm)	1-3/4" (45 mm)	1-3/4" (45 mm)	1-3/4" (45 mm)	1-3/4" (45 mm)
C	4-7/32" (107 mm)	5-15/32" (139 mm)	6-9/32" (160 mm)	7-9/16" (192 mm)	8-7/16" (214 mm)	10-5/8" (270 mm)	12-13/16" (325 mm)	14-27/32" (377 mm)	17-13/64" (437 mm)	19-7/32" (488 mm)	21-1/2" (546 mm)
D	2" (51 mm)	3" (76 mm)	4" (102 mm)	5" (127 mm)	6" (152 mm)	8" (203 mm)	10" (254 mm)	12" (305 mm)	14" (356 mm)	16" (406 mm)	18" (457 mm)
E	7.18" (182 mm)	8.44" (214 mm)	9.27" (235 mm)	10.53" (267 mm)	11.40" (289 mm)	13.60" (345 mm)	15.77" (400 mm)	17.81" (452 mm)	20.17" (512 mm)	22.18" (563 mm)	24.47" (621 mm)

All Non-Metallic



TYPE 5

- For wastewater and chemical feed applications, as well as applications with corrosive media
- Constructed of corrosion-resistant PP glass fiber reinforced upper housing and PP, PVC or PVDF lower housing
- Protects pressure instruments used on ultra-pure or highly corrosive fluid lines such as demineralized water, sulfuric acid, hydrochloric acid, and caustics
- PTFE-coated EPDM diaphragms are standard on all assemblies
- 100% non-metallic wetted surfaces assures maximum chemical and temperature compatibility

APPLICATIONS

- Wastewater and chemical feed
- Deionized water systems
- Reverse osmosis systems
- Desalination systems
- Electroplating

SPECIFICATIONS

SPECIFICATIONS				
Seal type	Threaded with non-replaceable diaphragm			
Instruments	Type	Size	Minimum Pressure	Maximum Pressure
	Gauges	2-1/2" to 6"	0 psig to 30 psig	0 psig to 160 psig
	Transducers	-	0 psig to 30 psig	0 psig to 160 psig
	Switches	-	0 psig to 30 psig	0 psig to 160 psig
Upper housing	Type	Non-continuous duty		
	Connections	1/4" NPT, 1/2" NPT		
	Materials	PP, fiberglass reinforced		
Diaphragm	Size	1.77"		
	Displacement	8.9 ml		
	Materials	EPDM, PTFE-coated		
Lower housing	Connections	1/4" NPT or 1/2" NPT		
	Materials	PVC, PP or PVDF		
Operating temperature	Operating temperature is determined by the temperature/pressure configuration. See Material Temperature table.			

ORDERING INFORMATION			
TYPE	5		
INSTRUMENT CONNECTION SIZES	02 1/4" NPT	04 1/2" NPT	
UPPER HOUSING MATERIAL	PP PP		
DIAPHRAGM MATERIAL	E EPDM-PTFE coated on process side		
PROCESS CONNECTION SIZES	02 1/4" NPT	04 1/2" NPT	
LOWER HOUSING MATERIAL	PV PVC	PP PP	KN PVDF

Please consult your local NOSHOK Distributor or NOSHOK, Inc. for availability and delivery information.

EXAMPLE

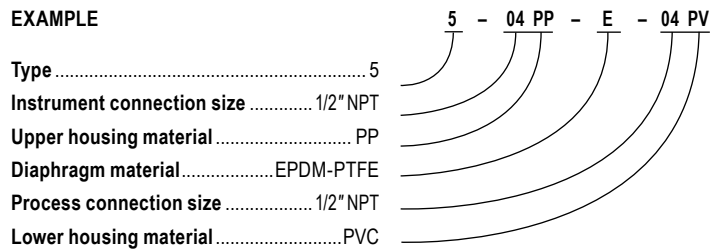

Type 5

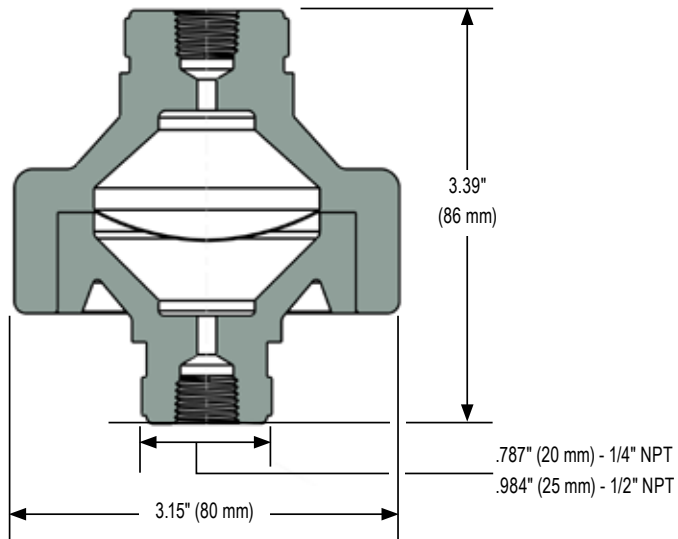

Sanitary, Clamped-Style, ASME-BPE

TYPE 12



- Features a flush mount diaphragm and all welded construction, ideal for food & beverage, pharmaceutical and sanitary markets
- Can be used for remote mounting of pressure instrument(s) with capillary
- Wetted parts and all welded housing are constructed of 316 stainless steel for greater strength and durability
- Accommodates process connection pipes from 1-1/2" through 3" sizes
- Clamped connection allows ease of installation and removal of seal for maintenance and cleaning
- Wetted materials polished to Ra 32 or better
- Consider instrument size, pressure range, media composition, ambient and operating temperature, and maximum working pressure when selecting
- Capillaries and cooling elements are available for elevated process temperatures, see page 24
- Fill fluid must be compatible with process media; i.e. Glycerin may become volatile in conjunction with a strong oxidizing agent such as chlorine, forms of oxygen or peroxide and nitric acids

APPLICATIONS

- Water and wastewater
- Oil and gas
- Petrochemical
- Chemical processing
- Industrial automation
- Food and beverage
- Marine
- Agriculture
- Steel fabrication
- Mud pumping
- Pharmaceutical
- Pulp and paper
- Pneumatic

SPECIFICATIONS

SPECIFICATIONS					
Seal type	Sanitary clamp, welded diaphragm				
Instruments	Type	Size	Minimum Pressure	Maximum Pressure	
	Gauges	2-1/2" to 4"	0 psig to 30 psig	Determined by the clamping device and piping system.	
	Transducers	-	0 psig to 30 psig		
Switches	-	0 psig to 30 psig			
Upper housing	Type	Continuous duty			
	Connections	1/4" NPT, 1/2" NPT			
	Materials	316 Stainless steel			
Diaphragm		1-1/2" Pipe	2" Pipe	2-1/2" Pipe	3" Pipe
	Size	1.4"	1.9"	2.4"	2.9"
	Displacement	190 mm ³	490 mm ³	850 mm ³	1,670 mm ³
	Material	316 Stainless steel			
Operating temperature	Operating temperature is determined by the temperature/pressure configuration. See Material Temperature table.				

ORDERING INFORMATION				
TYPE	12			
INSTRUMENT CONNECTION SIZES	02 1/4" NPT	04 1/2" NPT		
UPPER HOUSING MATERIAL	S 316 Stainless steel			
DIAPHRAGM MATERIAL	S 316 Stainless steel			
SANITARY PIPE SIZES	12 1-1/2"	16 2"	20 2-1/2"	24 3"
OPTIONAL SANITARY SEAL CLAMPS & GASKETS				
SS ASME-BPE CLAMPS	CR12 1-1/2"	CR16 2"	CR20 2-1/2"	CR24 3"
NBR GASKETS	BG12 1-1/2"	BG16 2"	BG20 2-1/2"	BG24 3"
PTFE GASKETS	TG12 1-1/2"	TG16 2"	TG20 2-1/2"	TG24 3"

Please consult your local NOSHOK Distributor or NOSHOK, Inc. for availability and delivery information.

EXAMPLE

Type 12
 Instrument connection size 1/4" NPT
 Upper housing material 316 Stainless steel
 Diaphragm material 316 Stainless steel
 Sanitary pipe size 2-1/2"
 SS ASME-BPE clamp (optional) 2-1/2" clamp
 Gasket material (optional) NBR

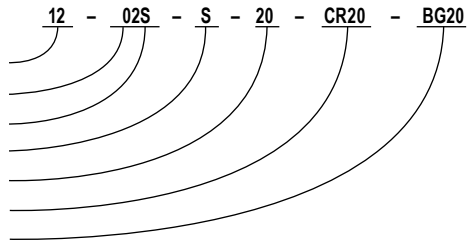

1-1/2" Nominal Pipe Size **2" Nominal Pipe Size**

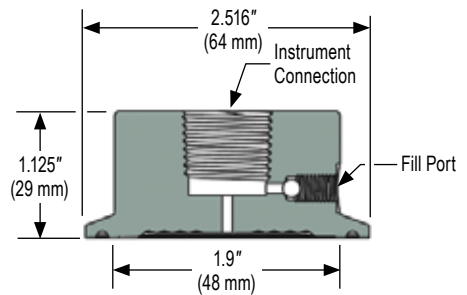
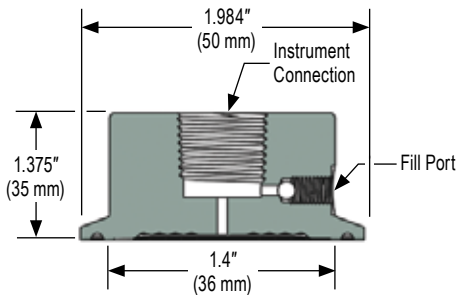

2-1/2" Nominal Pipe Size **3" Nominal Pipe Size**

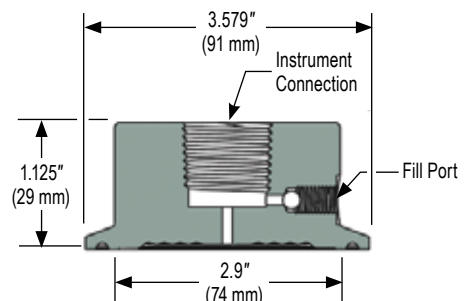
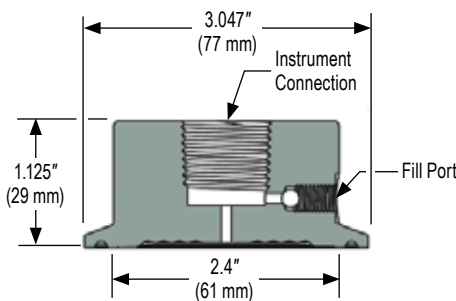

Front Flush

TYPE 20



- Designed for applications requiring an NPT male threaded process connection and with a flush diaphragm
- Flush diaphragm construction prevents clogging and process material build-up
- Constructed with a 316 stainless steel housing and diaphragm for strength and durability
- Available instrument connection sizes are 1/4" and 1/2" with a process connection size of 1/2" NPT male to 2" NPT male
- Consider instrument size, pressure range, media composition, ambient and operating temperature, and maximum working pressure when selecting
- Capillaries and cooling elements are available for elevated process temperatures, see page 24
- Fill fluid must be compatible with process media; i.e. Glycerin may become volatile in conjunction with a strong oxidizing agent such as chlorine, forms of oxygen or peroxide and nitric acids

APPLICATIONS

- Water and wastewater
- Oil and gas
- Petrochemical
- Chemical processing
- Industrial automation
- Marine
- Agriculture
- Steel fabrication
- Mud pumping
- Pharmaceutical
- Pulp and paper
- Pneumatic



Front flush diaphragm

SPECIFICATIONS

SPECIFICATIONS						
Seal type	Sanitary clamp, welded diaphragm					
Instruments	Type	Size	Minimum Pressure	Maximum Pressure		
Seal Connection Size 1/2" NPT	Gauges	2-1/2"	0 psig to 1,500 psig	0 psig to 9,000 psig		
	Transducers	-	0 psig to 30 psig	0 psig to 9,000 psig		
	Switches	-	0 psig to 30 psig	0 psig to 9,000 psig		
Seal Connection Size 3/4" NPT	Gauges	2-1/2"	0 psig to 160 psig	0 psig to 9,000 psig		
	Gauges	4" to 4-1/2"	0 psig to 1,500 psig	0 psig to 9,000 psig		
	Transducers	-	0 psig to 30 psig	0 psig to 9,000 psig		
Seal Connection Size 1" NPT	Switches	-	0 psig to 30 psig	0 psig to 9,000 psig		
	Gauges	2-1/2"	0 psig to 160 psig	0 psig to 9,000 psig		
	Gauges	4" to 4-1/2"	0 psig to 1,000 psig	0 psig to 9,000 psig		
Upper Housing	Type	Continuous duty				
	Connections	1/4" NPT, 1/2" NPT				
	Material	316 Stainless steel				
Diaphragm		1/2" NPT	3/4" NPT	1" NPT	1-1/2" NPT	2" NPT
	Size	0.7"	0.9"	1.0"	1.6"	2.0"
	Displacement	50 mm ³	100 mm ³	180 mm ³	550 mm ³	1,000 mm ³
	Material	316 Stainless steel				
Operating temperature	Operating temperature is determined by the temperature/pressure configuration. See Material Temperature table.					

ORDERING INFORMATION			
TYPE	20		
INSTRUMENT CONNECTION SIZES	02 1/4" NPT	04 1/2" NPT	
HOUSING MATERIAL	S 316 Stainless steel		
DIAPHRAGM MATERIAL	S 316 Stainless steel		
PROCESS CONNECTION SIZES	04 1/2" NPT	08 1" NPT	16 2" NPT
	06 3/4" NPT	12 1-1/2" NPT	

Please consult your local NOSHOK Distributor or NOSHOK, Inc. for availability and delivery information.

EXAMPLE

20 - 02 S - S - 06
 Type 20
 Instrument connection size 1/4" NPT
 Housing material 316 Stainless steel
 Diaphragm material 316 Stainless steel
 Process connection size 3/4" NPT

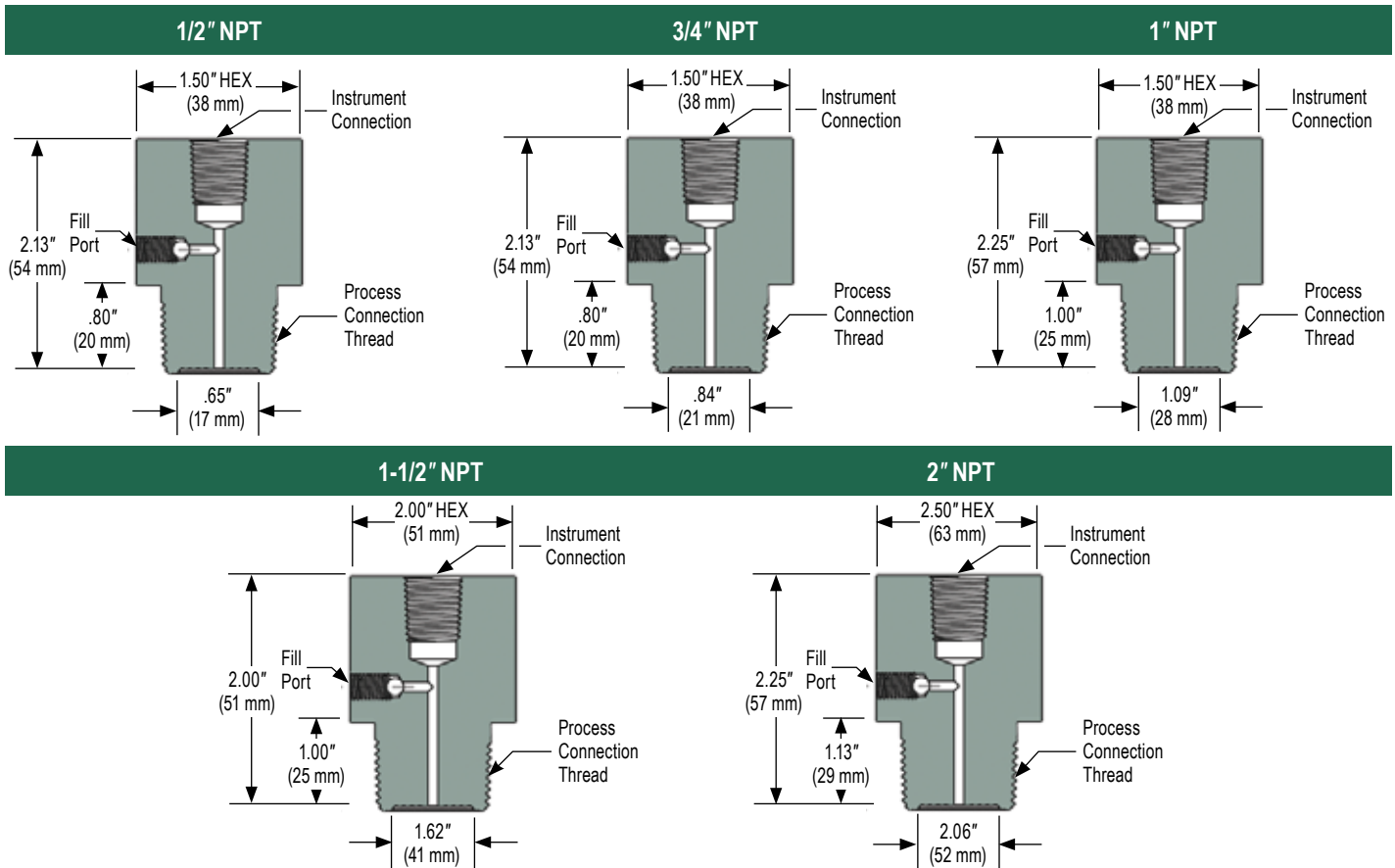

Standard & Elevated Pressure

TYPE 25/25H



- Designed to isolate the pressure measuring instrument from corrosive or viscous process media
- Utilize an all welded, all metallic housing design to eliminate potential leak paths
- For use with gauges with dial sizes of 2-1/2" and smaller, and pressure ranges no less than 100 psig
- Housing and diaphragm offered in a variety of materials to suit most applications
- A flushing port is available to clean wetted areas and prevent process media build up
- Consider instrument size, pressure range, media composition, ambient and operating temperature, and maximum working pressure when selecting
- Capillaries and cooling elements are available for elevated process temperatures, see page 24
- Fill fluid must be compatible with process media; i.e. Glycerin may become volatile in conjunction with a strong oxidizing agent such as chlorine, forms of oxygen or peroxide and nitric acids

APPLICATIONS

- Water and wastewater
- Oil and gas
- Petrochemical
- Chemical processing
- Industrial automation
- Marine
- Agriculture
- Steel fabrication
- Mud pumping
- Pulp and paper
- Pneumatic

SPECIFICATIONS

SPECIFICATIONS				
Seal type	Threaded with welded diaphragm			
Instruments	Type	Size	Minimum Pressure	Maximum Pressure
	Gauges	2-1/2"	0 psig to 100 psig	0 psig to 2,500 psig (25H - 5,000 psig)
	Transducers	-	0 psig to 60 psig	0 psig to 2,500 psig (25H - 5,000 psig)
	Switches	-	0 psig to 60 psig	0 psig to 2,500 psig (25H - 5,000 psig)
Upper housing	Type	Non-continuous duty		
	Connections	1/4" NPT, 1/2" NPT		
	Materials	316 Stainless steel		
Diaphragm	Size	1.28"		
	Displacement	400 mm ³		
	Materials	316 Stainless steel (Exotic materials available on request)		
Lower housing	Connections	1/4" NPT, 1/2" NPT		
	Materials	316 Stainless steel (Exotic materials available on request)		
	Flushing port	Optional 1/8" NPT and 1/4" NPT		
Operating temperature	Operating temperature is determined by the temperature/pressure configuration. See Material Temperature table.			

ORDERING INFORMATION				
TYPE	25 (2,500 psi)	25H (5,000 psi)		
INSTRUMENT CONNECTION SIZES	02 1/4" NPT	04 1/2" NPT		
UPPER HOUSING MATERIALS	M Monel 400	P Carpenter 20	S 316 Stainless steel	
DIAPHRAGM MATERIALS	H Hastelloy C-276	M Monel 400 ¹	P Carpenter 20 ¹	S 316 Stainless steel
PROCESS CONNECTION SIZES	02 1/4" NPT	04 1/2" NPT		
LOWER HOUSING MATERIALS	H Hastelloy C-276	M Monel 400	P Carpenter 20	S 316 Stainless steel
FLUSHING CONNECTIONS	1F 1/8" NPT	2F 1/4" NPT		

Please consult your local NOSHOK Distributor or NOSHOK, Inc. for availability and delivery information.

¹ When selecting a Monel or Carpenter 20 Diaphragm, the upper & lower housing must be the same material

EXAMPLE

Type 25
 Instrument connection size 1/4" NPT
 Upper housing material Carpenter 20
 Diaphragm material Carpenter 20
 Process connection size 1/2" NPT
 Lower housing material Carpenter 20
 Flushing connection (optional) 1/8" NPT

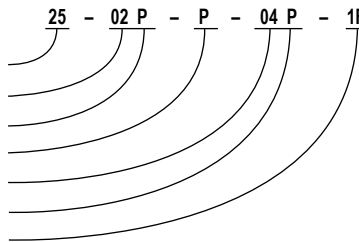

Type 25 Standard Pressure

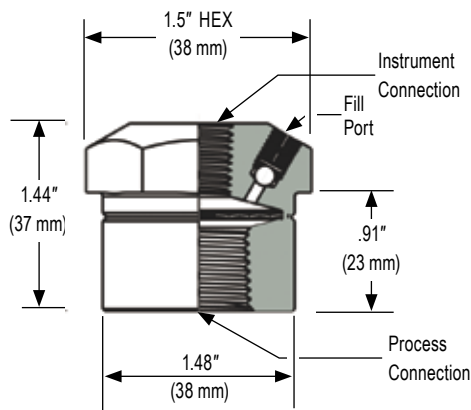

Type 25H Elevated Pressure

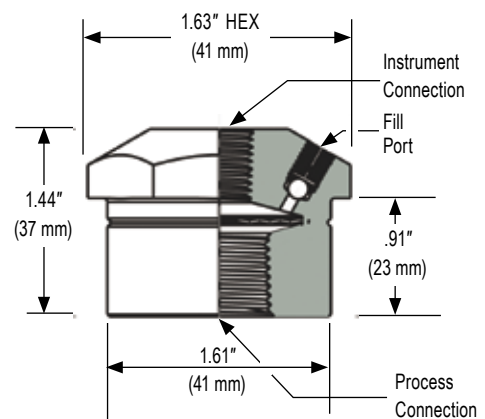

High Volumetric Displacement

TYPE 29



- An off-line seal with a threaded connection and all welded, all metallic housing design that does not utilize an o-ring or gasket
- Can be used for remote mounting of pressure instrument(s) with capillary
- Designed with a larger diameter diaphragm for higher displacement capability
- A variety of upper and lower housing and diaphragm materials are available to suit most applications
- A flushing port is available to clean wetted areas and prevent process media build up
- Consider instrument size, pressure range, media composition, ambient and operating temperature, and maximum working pressure when selecting
- Capillaries and cooling elements are available for elevated process temperatures, see page 24
- Fill fluid must be compatible with process media; i.e. Glycerin may become volatile in conjunction with a strong oxidizing agent such as chlorine, forms of oxygen or peroxide and nitric acids

APPLICATIONS

- Water and wastewater
- Oil and gas
- Petrochemical
- Chemical processing
- Industrial automation
- Marine
- Agriculture
- Steel fabrication
- Mud pumping
- Pulp and paper
- Pneumatic

SPECIFICATIONS

SPECIFICATIONS				
Seal type	Threaded with welded diaphragm.			
Instruments	Type	Size	Minimum Pressure	Maximum Pressure
	Gauges	2-1/2" to 4-1/2"	0 psig to 30 psig	0 psig to 2,500 psig
	Transducers	-	0 psig to 30 psig	0 psig to 2,500 psig
	Switches	-	0 psig to 30 psig	0 psig to 2,500 psig
Upper housing	Type	Continuous duty		
	Connections	1/4" NPT, 1/2" NPT		
	Materials	316 Stainless steel		
Diaphragm	Size	2.1"		
	Displacement	1.5 ml		
	Materials	316 Stainless steel (Exotic materials available on request)		
Lower housing	Connections	1/4" NPT, 1/2" NPT, 3/4" NPT, 1" NPT		
	Materials	316 Stainless steel (Exotic materials available on request)		
	Flushing port	Optional 1/8" NPT and 1/4" NPT		
Operating temperature	Operating temperature is determined by the temperature/pressure configuration. See Material Temperature table.			

ORDERING INFORMATION			
TYPE	29		
INSTRUMENT CONNECTION SIZES	02 1/4" NPT	04 1/2" NPT	
UPPER HOUSING MATERIALS	M Monel 400	S 316 Stainless steel	P Carpenter 20
DIAPHRAGM MATERIALS	H Hastelloy C-276	P Carpenter 20 ¹	
	M Monel 400 ¹	S 316 Stainless steel	
PROCESS CONNECTION SIZES	02 1/4" NPT	06 3/4" NPT	
	04 1/2" NPT	08 1" NPT	
LOWER HOUSING MATERIALS	H Hastelloy C-276	P Carpenter 20	
	M Monel 400	S 316 Stainless steel	
FLUSHING CONNECTIONS	1F 1/8" NPT	2F 1/4" NPT	

Please consult your local NOSHOK Distributor or NOSHOK, Inc. for availability and delivery information.

¹ When selecting a Monel or Carpenter 20 Diaphragm, the upper & lower housing must be the same material

EXAMPLE

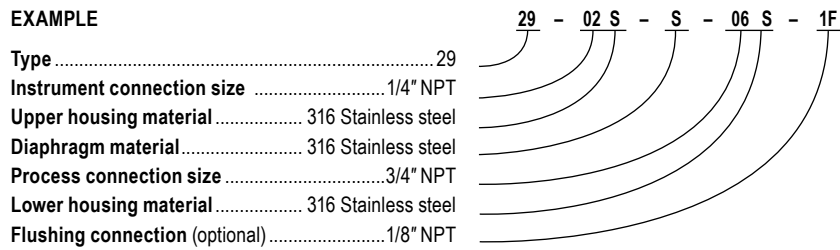

Type 29

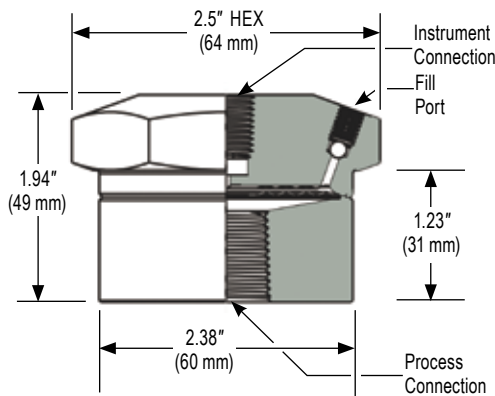

Standard & Elevated Pressure, Bolted

TYPE 30/30H



- Utilizes an all metallic diaphragm welded to the upper housing to allow field replacement of the lower housing while maintaining continuity of the measuring system
- Can be used for remote mounting of pressure instrument(s) with capillary
- A wide variety of instrument and process connections are available
- A flushing port is available to clean wetted areas and prevent process media build up
- Consider instrument size, pressure range, media composition, ambient and operating temperature, and maximum working pressure when selecting
- Capillaries and cooling elements are available for elevated process temperatures, see page 24
- Fill fluid must be compatible with process media; i.e. Glycerin may become volatile in conjunction with a strong oxidizing agent such as chlorine, forms of oxygen or peroxide and nitric acids

APPLICATIONS

- Water and wastewater
- Oil and gas
- Petrochemical
- Chemical processing
- Industrial automation
- Marine
- Agriculture
- Steel fabrication
- Mud pumping
- Pulp and paper
- Pneumatic

SPECIFICATIONS

Seal type	Threaded with welded diaphragm (Flanged available on request)			
Instruments	Type	Size	Minimum Pressure	Maximum Pressure
	Gauges	2-1/2" to 6"	0 psig to 30 psig	0 psig to 2,500 psig (30H - 5,000 psig)
	Transducers	-	0 psig to 30 psig	0 psig to 2,500 psig (30H - 5,000 psig)
	Switches	-	0 psig to 30 psig	0 psig to 2,500 psig (30H - 5,000 psig)
Upper housing	Type	Continuous duty		
	Connections	1/4" NPT, 1/2" NPT		
	Materials	Polyurethane enamel coated steel, 316 Stainless steel		
Diaphragm	Size	2.4"		
	Displacement	1.5 ml		
	Materials	316 Stainless steel (Exotic materials available on request)		
Gaskets	Type 30	Klingsil C-440, PTFE and FKM		
	Type 30H	FEP encapsulated o-ring (5,000 psi)		
Lower housing	Connections	1/4" NPT, 1/2" NPT, 3/4" NPT, 1" NPT, 1-1/4" NPT and 1-1/2" NPT		
	Materials	Polyurethane enamel coated steel, 316 Stainless steel (Exotic materials available on request)		
	Flushing port	Optional 1/8" NPT, 1/4" NPT and dual ports		
Bolting	Zinc-plated steel, optional Stainless steel			
Operating temperature	Operating temperature is determined by the temperature/pressure configuration. See Material Temperature table.			

ORDERING INFORMATION				
TYPE	30 (2,500 psi)	30H (5,000 psi)		
INSTRUMENT CONNECTION SIZES	02 1/4" NPT	04 1/2" NPT		
UPPER HOUSING MATERIALS	C Carbon steel M Monel 400	P Carpenter 20 S 316 Stainless steel	U Titanium Grade 4	
DIAPHRAGM MATERIALS	A Tantalum H Hastelloy C-276	M Monel 400 ¹ N Inconel 600	P Carpenter 20 ¹ S 316 Stainless steel	U Titanium Grade 4 ¹
SEAL GASKET MATERIALS	F FEP encapsulated o-ring (5,000 psi) R Klingsil C-4401 (Rated to 1,500 psi)	T PTFE V FKM		
PROCESS CONNECTION SIZES	02 1/4" NPT 04 1/2" NPT (ASME and DIN Flanges Available Upon Request)	06 3/4" NPT 08 1" NPT	10 1-1/4" NPT 12 1-1/2" NPT	
LOWER HOUSING MATERIALS	C Carbon Steel H Hastelloy C-276	M Monel 400 N Inconel 600	P Carpenter 20 S 316 Stainless Steel	U Titanium Grade 4
FLUSHING CONNECTIONS	1F 1/8" NPT	2F 1/4" NPT		

Please consult your local NOSHOK Distributor or NOSHOK, Inc. for availability and delivery information.

¹When selecting a Monel 400, Carpenter 20 or Titanium Grade 4 Diaphragm, the upper housing must be the same material

EXAMPLE

Type	30	30
Instrument connection size	1/2" NPT	04
Upper housing material	316 Stainless steel	S
Diaphragm material	316 Stainless steel	S
Seal gasket material	Klingsil C-4401	R
Process connection size	1/2" NPT	04
Lower housing material	316 Stainless steel	S
Flushing connection (optional)	1/8" NPT	1F

Type 30 Standard Pressure

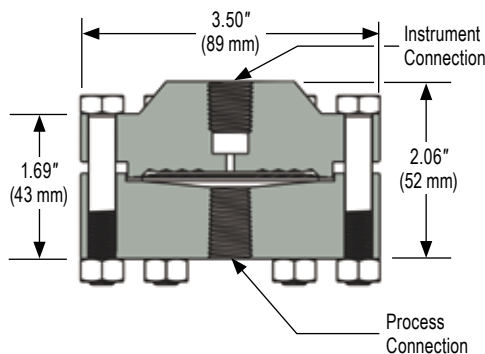

Type 30H Elevated Pressure

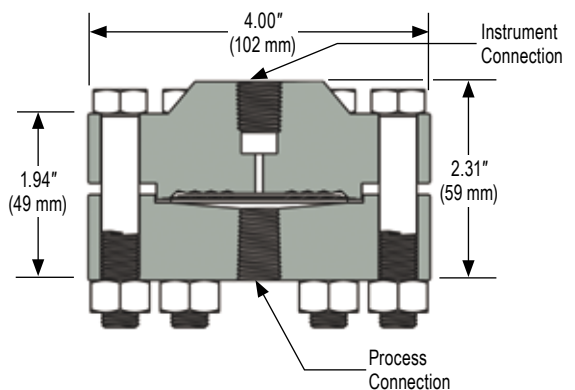

Reduced Pressure, Non-Metallic Lower, Bolted

TYPE 30L



- Designed for applications where typical metallic lower housings cannot withstand process media
- Can be used for remote mounting of pressure instrument(s) with capillary
- Utilizes an all metallic diaphragm welded to the upper housing to allow replacement of the non-metallic lower housing while maintaining continuity of the measuring system
- Consider instrument size, pressure range, media composition, ambient and operating temperature, and maximum working pressure when selecting
- Fill fluid must be compatible with process media; i.e. Glycerin may become volatile in conjunction with a strong oxidizing agent such as chlorine, forms of oxygen or peroxide and nitric acids

APPLICATIONS

- Water and wastewater
- Oil and gas
- Petrochemical
- Chemical processing
- Industrial automation
- Marine
- Agriculture
- Steel fabrication
- Mud pumping
- Pulp and paper
- Pneumatic

SPECIFICATIONS

SPECIFICATIONS				
Seal type	Threaded with welded diaphragm (Flanged available on request)			
Instruments	Type	Size	Minimum Pressure	Maximum Pressure
	Gauges	2-1/2" to 6"	0 psig to 30 psig	0 psig to 200 psig
	Transducers	-	0 psig to 30 psig	0 psig to 200 psig
	Switches	-	0 psig to 30 psig	0 psig to 200 psig
Upper housing	Type	Continuous duty		
	Connections	1/4" NPT, 1/2" NPT		
	Materials	Polyurethane enamel coated steel, 316 Stainless steel		
Diaphragm	Size	2.4"		
	Displacement	1.5 ml		
	Materials	316 Stainless steel, FKM, PTFE (Exotic materials available on request)		
Gasket	NBR, PTFE and FKM			
Lower housing	Connections	1/4" NPT, 1/2" NPT, 3/4" NPT, 1" NPT, 1-1/4" NPT and 1-1/2" NPT		
	Materials	PVDF, PP, PVC, PTFE (Other materials available on request)		
Bolting	Zinc-plated steel, optional Stainless steel			
Operating temperature	Operating temperature is determined by the temperature/pressure configuration. See Material Temperature table.			

ORDERING INFORMATION				
TYPE	30L			
INSTRUMENT CONNECTION SIZES	02 1/4" NPT	04 1/2" NPT		
UPPER HOUSING MATERIALS	C Carbon steel	P Carpenter 20	U Titanium Grade 4	
	M Monel 400	S 316 Stainless steel		
DIAPHRAGM MATERIALS	A Tantalum	M Monel 400 ¹	P Carpenter 20 ¹	U Titanium Grade 4 ¹
	H Hastelloy C-276	N Inconel 600	S 316 Stainless steel	
SEAL GASKET MATERIALS	R Klingsil C-4401	T PTFE	V FKM	
PROCESS CONNECTION SIZES	02 1/4" NPT	06 3/4" NPT	10 1-1/4" NPT	
	04 1/2" NPT	08 1" NPT	12 1-1/2" NPT	
(ASME and DIN flanges available upon request)				
LOWER HOUSING MATERIALS	KN PVDF	PV PVC	TG PTFE (glass filled)	
	PP PP	TC PTFE (carbon filled)		

Please consult your local NOSHOK Distributor or NOSHOK, Inc. for availability and delivery information.

¹ When selecting a Monel 400, Carpenter 20 or Titanium Grade 4 diaphragm, the upper housing must be the same material

EXAMPLE

Type30L
 Instrument connection size1/4" NPT
 Upper housing material Carbon steel
 Diaphragm material316 Stainless steel
 Seal gasket materialKlingsil C-4401
 Process connection size3/4" NPT
 Lower housing materialPVC

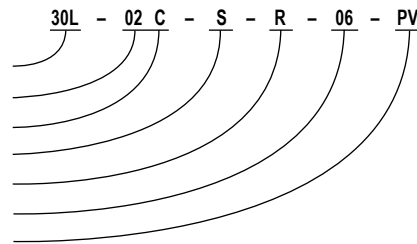

Type 30L PTFE Carbon / PTFE Glass
Type 30L PVC / PP / PVDF

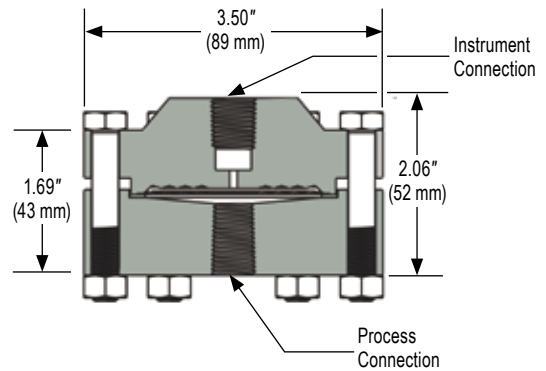
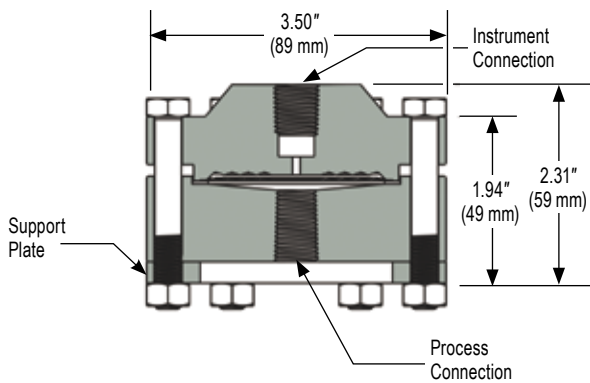

Accessories

PLAIN AND ARMORED CAPILLARIES

- Stainless steel capillaries available with or without stainless steel armor
- Protects the instrument from high or low process temperatures
- Allows remote mounting of pressure instrument(s)
- Select the shortest capillary length possible, as changes in ambient temperature conditions may significantly affect the accuracy and response time of the instrument
- Standard length 5', others available
- Installation on analog gauges requires a gauge support and gauge adaptor, or other surface mounting provisions
- Any level difference between the instrument and the seal will result in a pressure indication error; make sure to compensate for the level difference during calibration of the diaphragm seal assembly if the level difference is known



COOLING ELEMENTS

- Works in combination with diaphragm seal to isolate instrument from high media temperatures
- Recommended for process temperatures above 212 °F
- Requires direct mounted system
- Effective temperature reductions of 200 °F depending upon ambient conditions
- High >212 °F process temperature, low < -40 °F process temperature
- All stainless steel construction



SANITARY CLAMPS AND GASKETS

- Clamp-style fittings are constructed of T304 stainless steel; T316 stainless steel on request
- Double hinge design for easy installation and removal
- Available in sizes from 3/4" to 4"
- Standard pressure rating of 500 psi at 70 °F (21 °C); up to 3,000 psi rating on request
- Clamp gaskets are available in NBR, EPDM, PTFE and FKM
- All clamps and gaskets meet FDA and 3A sanitary standards



NOSHOK Flexible Capillaries	Part Number
5' SS armored capillary 1/4" NPT	AC-02-02-5
Custom length per foot	AC-02-02-#
5' SS armored capillary 1/2" NPT	AC-04-04-5
Custom length per foot	AC-04-04-#
5' SS plain capillary 1/4" NPT	PC-02-02-5
Custom length per foot	PC-02-02-#
5' SS plain capillary 1/2" NPT	PC-04-04-5
Custom length per foot	PC-04-04-#

NOSHOK Cooling Element	Part Number
1/4" NPT x 1/4" NPT, 4.68"	1/4-NPT-Cooling-Element
1/2" NPT x 1/2" NPT, 4.68"	1/2-NPT-Cooling-Element

NOSHOK Sanitary Clamps and Gaskets	Part Number
ASME-BPE Sanitary Clamp	
1-1/2" Tube OD	CR-12
2" Tube OD	CR-16
2-1/2" Tube OD	CR-20
3" Tube OD	CR-24
NBR Gasket	
1-1/2" Tube OD	BG-12
2" Tube OD	BG-16
2-1/2" Tube OD	BG-20
3" Tube OD	BG-24
PTFE Gasket	
1-1/2" Tube OD	TG-12
2" Tube OD	TG-16
2-1/2" Tube OD	TG-20
3" Tube OD	TG-24

Fill Fluid Temperature Table

Recommended Temperature Range				
Fill Fluid	Viscosity (cSt)	Vacuum/Compound	Pressure	$E_t (1/°F)$
Glycerin (99.7%)	1,110	N/A	60 °F to 462 °F	0.000294
Silicone 200	5	-130 °F to 176 °F	-130 °F to 356 °F	0.000588
Silicone 200	50	-4 °F to 250 °F	-4 °F to 392 °F	0.000582
Silicone 200, Food Grade	350	N/A	0 °F to 572 °F	0.000533
Silicone 510	50	-60 °F to 250 °F	-60 °F to 400 °F	0.000533
Silicone 550	125	-40 °F to 325 °F	-40 °F to 450 °F	0.000520
Silicone 710	500	0 °F to 348 °F	0 °F to 500 °F	0.000430
Halocarbon 4.2 Oil	4	-40 °F to 176 °F	-40 °F to 347 °F	0.000565
Syltherm 800	9	4 °F to 392 °F	-40 °F to 750 °F	0.000962
Mineral Oil	57	-4 °F to 338 °F	-4 °F to 482 °F	0.000356
Neobee M-20	10	-10 °F to 200 °F	-10 °F to 400 °F	0.000511

Material Temperature Table

Material	Pressure Limit	Temperature Limit
O-Ring Temperature Limits		
NBR	—	-40 °F to 250 °F
PTFE	—	-40 °F to 400 °F
FKM	—	-10 °F to 400 °F
Diaphragm Pressure and Temperature Limits		
PTFE	2,000 psi	-40 °F to 400 °F
FKM	2,000 psi	-10 °F to 400 °F
Metallic diaphragms determined by pressure range of seal type, restricted to temperature range of fill fluid.		
Bottom Housing Material Maximum Pressure & Temperature Limits		
TG, TC	200 psi	150 °F
PVDF	200 psi	180 °F
PVC	200 psi	74 °F
PVC	125 psi	125 °F
PVC	80 psi	150 °F
PP	200 psi	140 °F
Metallic lower housings determined by pressure range of seal type, restricted to temperature range of fill fluid.		

Type 5 Diaphragm Seal Pressure/Temperature Diagrams

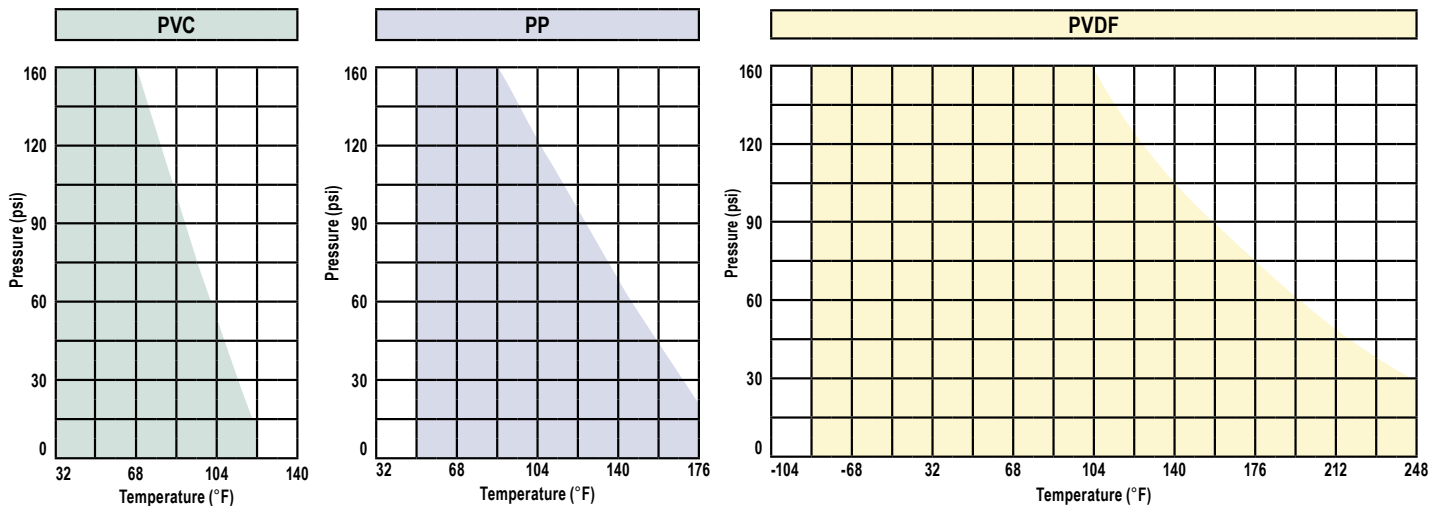

These values are a guide for harmless media against which the material of the seal is resistant.

Durability of wear and tear parts is depending on the operating conditions of the application. Values below 32 °F (PP < 50 °F) on request with exact data of operation.

Diaphragm Seals Thermal Error Calculations - Types 10, 25, 25H, 30

Three major factors contribute to thermal error:

- 1) Type of fill fluid used
- 2) Fill fluid volume
- 3) Diaphragm flexibility

The choice of fill fluid in Table I contributes directly to thermal errors in proportion to the coefficient of thermal expansion of the fluid. The resulting internal pressures produce adverse forces on the diaphragm which in turn are reflected in the pressure instrument.

The fill volumes in Table II & Table III contribute significantly to thermal errors. The greater the fill volume the greater volumetric expansion. Whenever possible, fill volumes should be minimized. If fill volumes cannot be adjusted, choose a fluid with the lowest coefficient of thermal expansion. The flexibility of the diaphragm is expressed as a spring rate (Table II). The smaller the diaphragm, the greater the spring rate. Any force used to move the diaphragm is considered an error because it subtracts from a direct reading of the pressure. Not only does it take more force to push a smaller diaphragm (spring bias), but high spring rates also reflect greater thermal errors when internal pressures push on it. It is desirable to have the lowest spring rate possible.

The thermal error (Err) can be expressed by the equations below. The first error formula (1) assumes a uniform gradual heating of the entire filled system. The second error formula (2) is used when the diaphragm, capillary and pressure instrument are at different temperatures and a thermal gradient exists.

Table I. Fill Fluid Expansion Factors

Recommended Temperature Range				
Fill Fluid	Viscosity (cSt)	Vacuum/Compound	Pressure	E _t (1/°F)
Glycerin (99.7%)	1,110	N/A	60 °F to 462 °F	0.000294
Silicone 200	5	-130 °F to 176 °F	-130 °F to 356 °F	0.000588
Silicone 200	50	-4 °F to 250 °F	-4 °F to 392 °F	0.000582
Silicone 200, Food Grade	350	N/A	0 °F to 572 °F	0.000533
Silicone 510	50	-60 °F to 250 °F	-60 °F to 400 °F	0.000533
Silicone 550	125	-40 °F to 325 °F	-40 °F to 450 °F	0.000520
Silicone 710	500	0 °F to 348 °F	0 °F to 500 °F	0.000430
Halocarbon 4.2 Oil	4	-40 °F to 176 °F	-40 °F to 347 °F	0.000565
Syltherm 800	9	4 °F to 392 °F	-40 °F to 750 °F	0.000962
Mineral Oil	57	-4 °F to 338 °F	-4 °F to 482 °F	0.000356
Neobee M-20	10	-10 °F to 200 °F	-10 °F to 400 °F	0.000511

Table II. Diaphragm Spring Rates and Volumes

Diaphragm Diameter Inches	Applicable Type	R _s	V _s
1.28	25	10,000	0.19
	25H		0.12
2.10	29	2,600	0.85
2.40	30	800	0.18
3.00	10	240	0.48

Table III. Accessory Internal Volume

Component	Volume
Capillary (1)	0.053"/ft ³
2" Nipple	0.024"/ft ³
2" Nipple	0.048"/ft ³

(1). Volume is based on capillary 1/8" (3.17 mm) O.D. x 0.025" (0.635 mm) wall

Equation 1

$$\text{Err} = (T)(E_t)(R_s)(V_T) \text{ expressed in inches H}_2\text{O}$$

Where:

- T = The number of degrees of the temperature change (°F).
- E_t = The coefficient of thermal expansion of the fill liquid (the volumetric change constant of the fill liquid per °F).
- R_s = The spring rate of the process diaphragm (inches H₂O pressure change/inch³ of fill liquid volume change).
- V_T = The total volume of the fill fluid in the diaphragm seal system (inches³).

Equation 2

$$\text{Err} = [(T_s \times V_s) + (T_p \times V_p \times L) + (T_D \times V_D)] [E_t] [R_s] \text{ expressed in inches H}_2\text{O}$$

Where:

- V_T = V_s + V_pL + V_D
- V_T = Total volume of filled system (inches³)
- V_s = Volume of seal (inches³)
- V_p = Volume of capillary (inches³/foot of length)
- V_D = Volume of inst. device (inches³)
- L = Length of capillary (feet)
- T_s = Change in temperature of liquid in seal (°F)
- T_p = Change in temperature of liquid in capillary (°F)
- T_D = Change in temperature of liquid in inst. device (°F)

In order to analyze the significance of these temperature induced errors, it is helpful to express the error as a % of measured span. This can easily be done by the following equation:

$$\text{Error \%} = \frac{\text{Err}}{\text{Measured Span (in inches H}_2\text{O)}} \times 100$$

TO DOWNLOAD OR ORDER CATALOGS,
VISIT WWW.NOSHOK.COM

Quality Policy

NOSHOK

is committed to providing a high degree of value and continually improving processes to improve customer satisfaction by focusing on customer requirements for the design, manufacture and distribution of pressure, temperature, and force measurement instruments along with needle and manifold valves including custom manifold systems for industrial applications.

All from world class technology.

Combined with real-world stamina.

The highest value with the industry's best warranty.

And all from a company with a 45+ year record of customer satisfaction.

All from your Single Source Instrumentation Company.



Corporate Headquarters

1010 West Bagley Road
Berea, Ohio 44017
Ph: 440.243.0888
Fax: 440.243.3472
E-mail: noshok@noshok.com
Web: www.noshok.com



NEEDLE VALVES

Soft Seat

mini valve

NOSHOK Multiport Gauge
reduce the number of gaug
and other instrument conn
to permanent fitting install
therefore decreasing possi
leak points (paths)

multiport

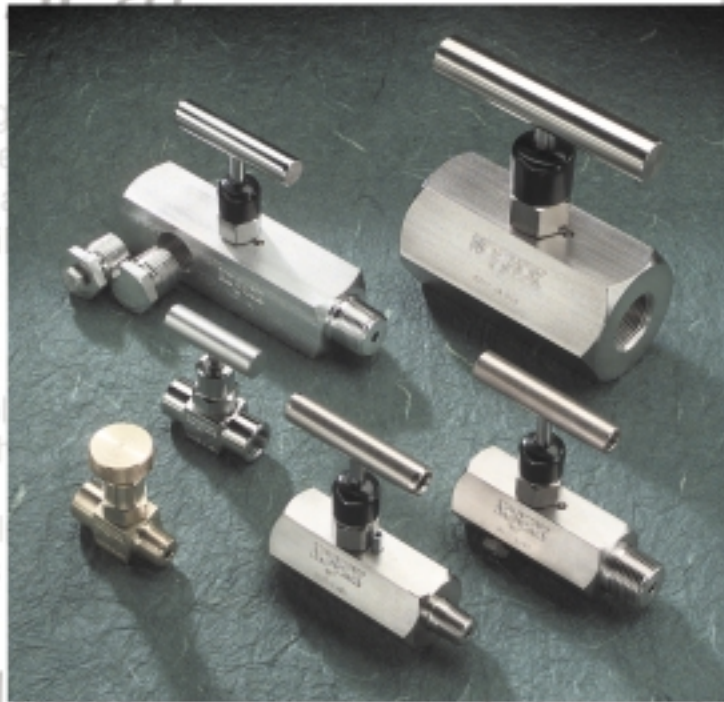

at a maximum pressure rating
of 6000 psi for the Stainless Steel
and Steel models

Stem and bonnet threads are
rolled for greater strength and
smoother operation

valve is the
-horse of the industry

Hard Seat

A precision molded, replaceable
is the key to the bubble tight
the Soft Seat Valve.
Typically used in gaseous appl
this valve will provide years
trouble free service.

Brass

3000 psi

6000 psi

block & bleed

Stainless Steel

The
Instrumentation
Company

NOSHOK NOSHOK NOSHOK NOSHOK NOSHOK NOSHOK
INCORPORATED

HOK NOSHOK NOSHOK NOSHOK NOSHOK NOSHOK NO

CompanyProfile

Established in 1967, NOSHOK was one of the first companies in America to offer liquid filled pressure gauges, a revolutionary concept at the time. More importantly, NOSHOK was the first company to stand behind its instrumentation products with extended warranties and we're still the leader today. The NOSHOK standard of quality and reliability continues to be the industry benchmark over 30 years later.

Today, NOSHOK pressure measurement instruments are sold through a network of over 270 distributors worldwide. Our continued commitment to product excellence, total service and our sincere desire to be the best provides the NOSHOK customer with a distinct edge.

Over the years we have expanded our program to meet the ever changing needs of our customers with additional pressure gauge products, pressure snubbers, diaphragm seals, bimetal thermometers, needle valves, solenoid valves, transducers, transmitters & digital indicators. And now with the latest expansion of our Needle Valve Offering.

The same high quality, superior performance and unsurpassed reliability that the industry has come to expect from other NOSHOK instrument products are now available in NOSHOK Needle Valves. Available in a multitude of materials, port configurations and seat types, NOSHOK Needle Valves are the right choice when positive shut off or precise flow control and metering of most gases and liquids is required.

Additionally, every NOSHOK Needle Valve is helium leak tested and fully checked for proper operation to insure 100% "out of the box" reliability.

NOSHOK also has the capability to provide you with the application assistance necessary to put together that special requirement which is often so hard to find. If it's not in our catalog, call us, we are confident we can satisfy your needs.

At NOSHOK, we proudly back our commitment to excellence with our warranties.
Thank You for choosing NOSHOK products.

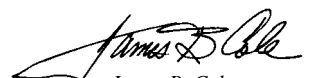

James B. Cole
Chief Executive Officer

Table of Contents

<i>Page</i>	
4-5	100Series <i>Mini Valves</i>
6-7	200&300Series <i>Multiport Valves</i>
8-9	400Series <i>Hard Seat Valves</i>
10-11	500Series <i>Soft Seat Valves</i>
12-13	600&700Series <i>Block & Bleed Valves</i>
14	Flow Characteristics

NOSHOK'S THREE YEAR WARRANTY

- to be free from defects in materials and workmanship
- to operate within catalogued performance specifications

The Needle Valves must be operated within the catalogued environmental and application parameters. Determination of failure will be made at NOSHOK using its equipment and personnel or a certified test facility specializing in this type of evaluation.

CAUTION

Operating conditions including but not limited to, system pressure, media compatibility and environmental conditions must be considered when selecting needle valves and options. Improper selection and use of needle valves could possibly cause failure and lead to possible property damage and/or personal injury.

DISCLAIMER

In keeping with and for the purposes of product and/or manufacturing process improvements, NOSHOK, Inc. reserves the right to make design and/or specification changes without prior notice.

NOSHOK is a member and actively supports:



100 SERIES mini VALVES



The **New NOSHOK 100 Series Mini Valve** is a big valve in a little package. Available in electroless nickel plated steel, electropolished stainless steel and brass, the **Mini Valve** was designed with your toughest applications in mind. All are equipped with both a Viton® O-Ring seal and a Teflon® back-up ring below the stem threads to protect the **Mini Valve** from corrosion and galling. The stem threads are rolled for strength and ease of operation, and the metal-to-metal hard seat design is *100% Helium leak tested* to 1×10^{-4} ml/s at 200 psi on each **Mini Valve**.

At a maximum pressure rating of 6000 psi for the Stainless Steel and Steel models and a 3000 psi rating for the Brass models, the **NOSHOK Mini Valve** has much to offer for such a little valve. With a variety of optional handles to choose from and the panel mount option, the **Mini Valve** will fit perfectly into any application.

Ordering Information

PART NUMBER	CONNECTION	MATERIAL
101 MMB	1/8 NPT Male-Male	Brass
102 MMB	1/4 NPT Male-Male	Brass
101 MMC	1/8 NPT Male-Male	Steel
102 MMC	1/4 NPT Male-Male	Steel
101 MMS	1/8 NPT Male-Male	Stainless Steel
102 MMS	1/4 NPT Male-Male	Stainless Steel
101 MFB	1/8 NPT Male-Female	Brass
102 MFB	1/4 NPT Male-Female	Brass
101 MFC	1/8 NPT Male-Female	Steel
102 MFC	1/4 NPT Male-Female	Steel
101 MFS	1/8 NPT Male-Female	Stainless Steel
102 MFS	1/4 NPT Male-Female	Stainless Steel
101 FFB	1/8 NPT Female-Female	Brass
102 FFB	1/4 NPT Female-Female	Brass
101 FFC	1/8 NPT Female-Female	Steel

PART NUMBER	CONNECTION	MATERIAL
102 FFC	1/4 NPT Female-Female	Steel
101 FFS	1/8 NPT Female-Female	Stainless Steel
102 FFS	1/4 NPT Female-Female	Stainless Steel
101 MFAB	1/8 NPT Male-Female Angle	Brass
102 MFAB	1/4 NPT Male-Female Angle	Brass
101 MFAC	1/8 NPT Male-Female Angle	Steel
102 MFAC	1/4 NPT Male-Female Angle	Steel
101 MFAS	1/8 NPT Male-Female Angle	Stainless Steel
102 MFAS	1/4 NPT Male-Female Angle	Stainless Steel
101 FFAB	1/8 NPT Female-Female Angle	Brass
102 FFAB	1/4 NPT Female-Female Angle	Brass
101 FFAC	1/8 NPT Female-Female Angle	Steel
102 FFAC	1/4 NPT Female-Female Angle	Steel
101 FFAS	1/8 NPT Female-Female Angle	Stainless Steel
102 FFAS	1/4 NPT Female-Female Angle	Stainless Steel

When ordering options please refer to the Part Number Construction guide below for the appropriate suffix. Please note that the standard O-Ring in all the **NOSHOK Mini Valves** are Viton® and the standard handles are:

Brass: Round Knurled (HL3) • **Steel:** Mini "T" (HL1) • **316SS:** Mini "T" (HL1)

The handle material will always match the material of the valve, unless otherwise specified. For example, the round knurled (HL3) on a 102 FFB will be brass. When only the standard configuration is needed, no additional designations are necessary. Please consult the factory for special application requests.

Part Number Construction: **102 FFC - PM2 - EM1 - HL4**

Panel Mount Options	O-Ring Options	Handle Options
PM1 - Panel Mount (1 nut) PM2 - Panel Mount (2 nuts)	EM1 - EPDM 80 KZ1 - Kalrez® 3018	HL1 - Mini "T" HL2 - "T" HL3 - Round Knurled HL4 - 1-3/8 Phenolic HL5 - 1-3/4 Phenolic

General Dimensions

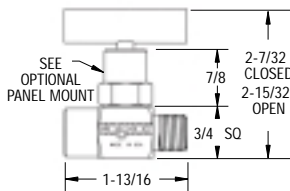

Male-Female w/"T"
handle option

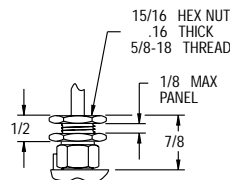

PANEL MOUNT DETAIL

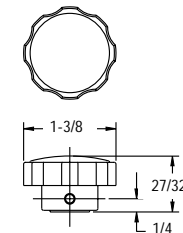

PHENOLIC HANDLE HL4

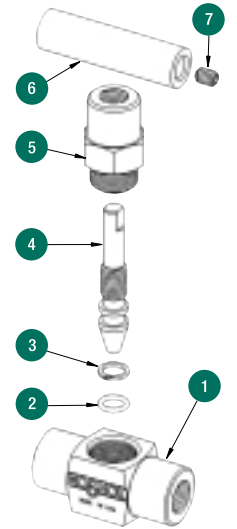
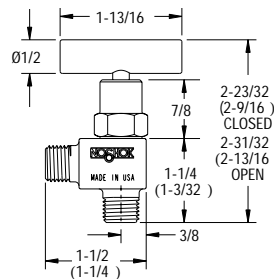
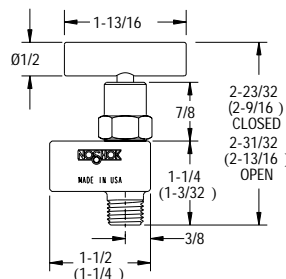
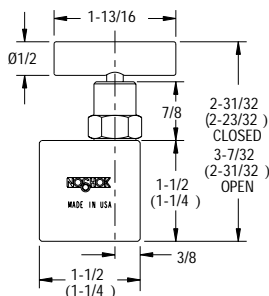

- 1 Mini Valve Body
- 2 Viton® O-Ring
- 3 Teflon® Back-up Ring
- 4 Mini Valve Stem
- 5 Mini Valve Bonnet
- 6 Mini Valve "T" Handle
- 7 Set Screw

For flow characteristics refer to page 14

Kalrez® and Viton® are registered trademarks of DuPont Dow Elastomers
Teflon® is a registered trademark of the DuPont Company

Technical Data:

Maximum Pressure Rating:	Orifice size:	0.172"
Steel: 6000 psi	Flow Coefficient:	0.42
Stainless Steel: 6000 psi	Standard O-Ring:	Viton®
Brass: 3000 psi	Standard Back-up Ring:	Teflon®

200&300 SERIES

multiport VALVES

HARD & SOFT SEAT



NOSHOK Multiport Gauge Valves reduce the number of gauge and other instrument connections to permanent piping installations, therefore decreasing possible leak points (paths). Optional bleed plugs further allow pressure to be bled off without disturbing the permanent piping installation.

HARD SEAT VALVE FEATURES

- Metal to metal hard seat design is 100% Helium leak tested to 1×10^{-4} ml/s at 200 psi.
- 10000 psi pressure rating (@ 200°F maximum)

SOFT SEAT VALVE FEATURES

- Soft seat design is 100% Helium leak tested to 1×10^{-4} ml/s at 200 psi.
- 6000 psi pressure rating (@ 200°F maximum)
- Replaceable Delrin seat.
- Straight through porting for bi-directional, high capacity flow and easy roddable cleaning.

STANDARD FEATURES FOR HARD SEAT and SOFT SEAT VALVES

- Blow-out proof stem that provides a secondary stem seal in the full open position.
- Stem packing below the threads prevents thread galling and contamination.
- Viton® O-Ring & Teflon® back-up ring stem seals.
- All 316SS stems (even in steel valves) for longer life.
- Stem and bonnet threads are rolled for greater strength and smoother operation.
- One piece bonnet with a metal to metal seal to the valve body below the bonnet threads.
- Bonnet lock pin to prevent accidental loosening.
- Vinyl bonnet and stem dust cap.
- .187 inch orifice size.
- Optional panel mount bonnet and panel nuts.
- Electroless Nickel plated finish on carbon steel valves.
- Electropolish finish on stainless steel valves.

Ordering Information

200 SERIES - HARD SEAT MULTI-PORT VALVES		
PART NUMBER	CONNECTION	MATERIAL
204 MFC	1/2 NPT Male-Female	Steel
20604 MFC	3/4 NPT Male- 1/2 NPT Female	Steel
204 MFS	1/2 NPT Male-Female	Stainless Steel
20604 MFS	3/4 NPT Male- 1/2 NPT Female	Stainless Steel

300 SERIES - SOFT SEAT MULTI-PORT VALVES		
PART NUMBER	CONNECTION	MATERIAL
304 MFC	1/2 NPT Male-Female	Steel
30604 MFC	3/4 NPT Male- 1/2 NPT Female	Steel
304 MFS	1/2 NPT Male-Female	Stainless Steel
30604 MFS	3/4 NPT Male- 1/2 NPT Female	Stainless Steel

NACE MRO175-99 CERTIFICATION (Consult Factory)

When ordering options please refer to the Part Number Construction guide below for the appropriate suffix. Please note that the standard O-Ring in all the **NOSHOK** Valves are Viton® and the standard handles are: "T" handles.

Part Number Construction: **304 MFC - PG - PM2 - EM1 - HL5**

PG - 200/300 Series Plug, Steel
 PG - 200/300 Series Plug, SS
 BP - 200/300 Series Bleed Plug, Steel
 BP - 200/300 Series Bleed Plug, SS
 All Plugs can also be ordered separately

Panel Mount Options
 PM1 - Panel Mount (1 nut)
 PM2 - Panel Mount (2 nuts)

O-Ring Options
 EM1 - EPDM 80
 KZ1 - Kalrez® 3018

Handle Options
 HL1 - Mini "T"
 HL2 - "T"
 HL3 - Round Knurled
 HL4 - 1-3/8 Phenolic
 HL5 - 1-3/4 Phenolic

General Dimensions

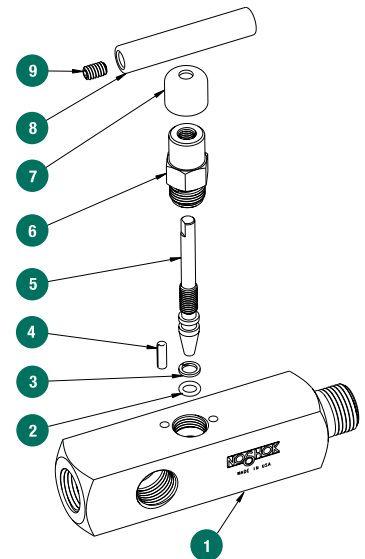
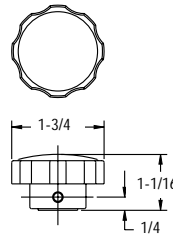
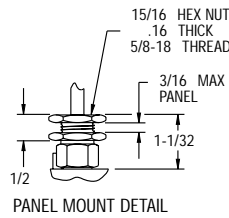
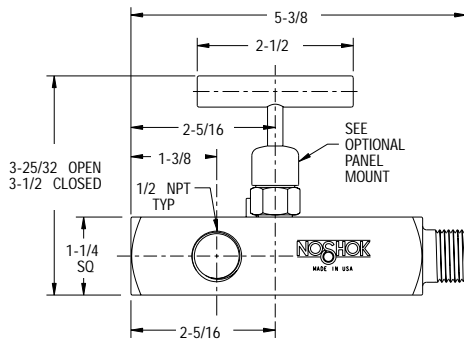

- 1 Valve Body
- 2 Viton® O-Ring
- 3 Teflon® Back-up Rings
- 4 Bonnet Lock Pin
- 5 Valve Stem
- 6 Valve Bonnet
- 7 Dust Cap
- 8 Valve Handle
- 9 Set Screw

Hard Seat Technical Data:

Maximum Pressure Rating: Orifice size: 0.187"
 Steel: 10000 psi **Flow Coefficient:** 0.44
 Stainless Steel: 10000 psi **Standard O-Ring:** Viton®
Standard Back-up Ring: Teflon®

Soft Seat Technical Data:

Maximum Pressure Rating: Orifice size: 0.187"
 Steel: 6000 psi **Flow Coefficient:** 0.64
 Stainless Steel: 6000 psi **Standard O-Ring:** Viton®
Standard Back-up Ring: Teflon®

For flow characteristics refer to page 14

Kalrez® and Viton® are registered trademarks of DuPont Dow Elastomers
 Teflon® is a registered trademark of the DuPont Company

400 SERIES hard seat VALVES



***THIS VALVE IS THE WORK-HORSE OF THE INDUSTRY...
and is fast becoming the standard that other hard seat needle valves are judged against.***

- Metal to metal hard seat design is *100% Helium leak tested* to 1×10^{-4} ml/s.
- 10,000 psi pressure rating (@200°F maximum).
- Blow out proof stem that provides a secondary stem seal in the full open position.
- Stem packing below the threads prevents thread galling & corrosion.
- Viton O-Ring & Teflon back-up ring stem seals.
- All 316SS stems (even in steel valves) for longer life.
- Stem and bonnet threads are rolled for greater strength and smoother operation.
- Angled stem for precise flow metering.
- One piece bonnet with a metal to metal seal to the valve body below the bonnet threads.
- Bonnet lock pin to prevent accidental loosening.
- Vinyl bonnet & stem dust cap.
- Optional panel mount bonnet and panel nuts.
- Electroless Nickel plated finish on carbon steel valves.
- Electropolish finish on stainless steel valves.

Ordering Information

PART NUMBER	CONNECTION	MATERIAL
402 MFC	1/4 NPT Male-Female	Steel
404 MFC	1/2 NPT Male-Female	Steel
406 MFC	3/4 NPT Male-Female	Steel
408 MFC	1 NPT Male-Female	Steel
410 MFC	1-1/4 NPT Male-Female	Steel
412 MFC	1-1/2 NPT Male-Female	Steel
402 MFS	1/4 NPT Male-Female	Stainless Steel
404 MFS	1/2 NPT Male-Female	Stainless Steel
406 MFS	3/4 NPT Male-Female	Stainless Steel
408 MFS	1 NPT Male-Female	Stainless Steel
410 MFS	1-1/4 NPT Male-Female	Stainless Steel
412 MFS	1-1/2 NPT Male-Female	Stainless Steel
402 FFC	1/4 NPT Female-Female	Steel
403 FFC	3/8 NPT Female-Female	Steel
404 FFC	1/2 NPT Female-Female	Steel
406 FFC	3/4 NPT Female-Female	Steel
408 FFC	1 NPT Female-Female	Steel
410 FFC	1-1/4 NPT Female-Female	Steel

PART NUMBER	CONNECTION	MATERIAL
412 FFC	1-1/2 NPT Female-Female	Steel
442 FFC	*7/16 -20 UNF-2B Female-Female	Steel
402 FFS	1/4 NPT Female-Female	Stainless Steel
403 FFS	3/8 NPT Female-Female	Stainless Steel
404 FFS	1/2 NPT Female-Female	Stainless Steel
406 FFS	3/4 NPT Female-Female	Stainless Steel
408 FFS	1 NPT Female-Female	Stainless Steel
410 FFS	1-1/4 NPT Female-Female	Stainless Steel
412 FFS	1-1/2 NPT Female-Female	Stainless Steel
442 FFS	*7/16 -20 UNF-2B Female-Female	Stainless Steel
402 MFAC	1/4 NPT Female-Female Angle	Steel
404 MFAC	1/2 NPT Male-Female Angle	Steel
402 MFAS	1/4 NPT Male-Female Angle	Stainless Steel
404 MFAS	1/2 NPT Male-Female Angle	Stainless Steel
402 FFAC	1/4 NPT Female-Female Angle	Steel
404 FFAC	1/2 NPT Female-Female Angle	Steel
402 FFAS	1/4 NPT Female-Female Angle	Stainless Steel
404 FFAS	1/2 NPT Female-Female Angle	Stainless Steel

When ordering options please refer to the Part Number Construction guide below for the appropriate suffix. Please note that the standard O-Ring in all the **NOSHOK** Valves are Viton® and the standard handles are: "T" handles. * SAE J1926-4 O-Ring Port.

Part Number Construction: 404 FFC - PM2 - EM1 - HL5

Panel Mount Options

PM1 - Panel Mount (1 nut)
PM2 - Panel Mount (2 nuts)

O-Ring Options

EM1 - EPDM 80
KZ1 - Kalrez® 3018

Handle Options

HL1 - Mini "T"
HL2 - "T"
HL3 - Round Knurled
HL4 - 1-3/8 Phenolic
HL5 - 1-3/4 Phenolic

General Dimensions

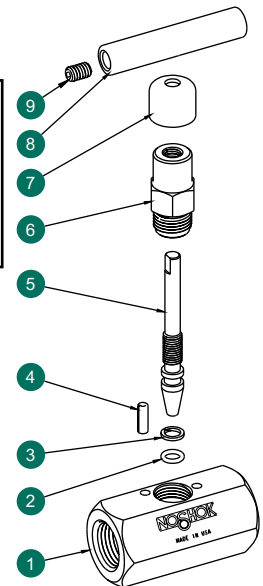
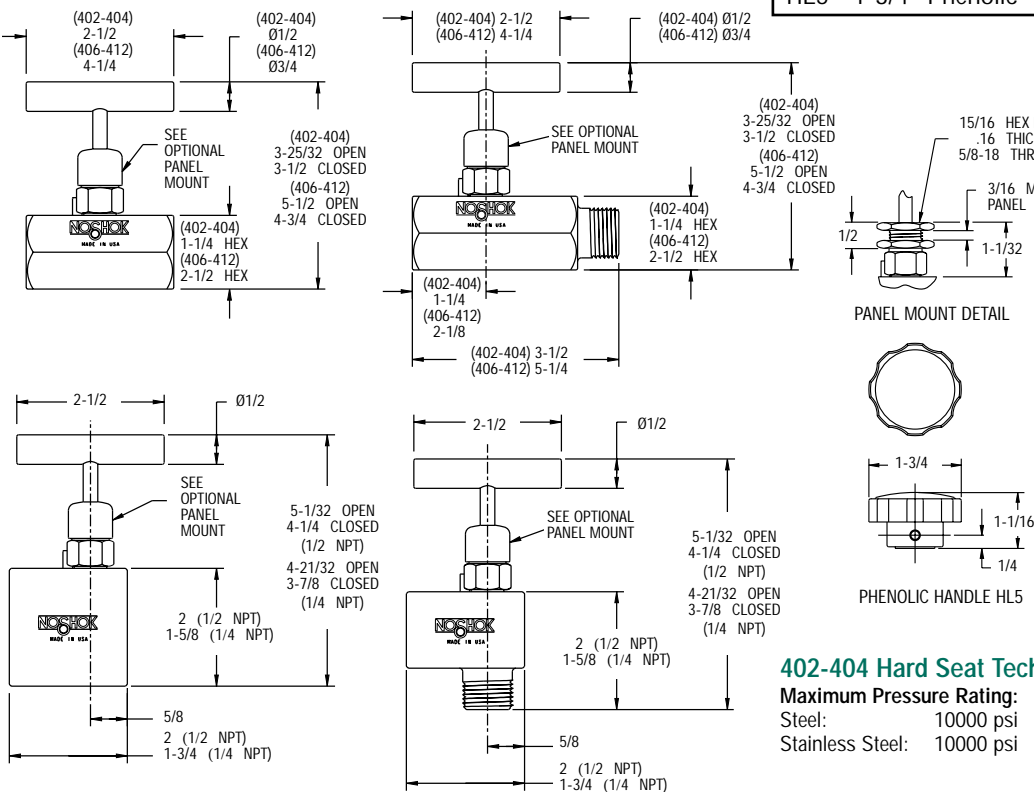

- 1 Valve Body
- 2 Viton® O-Ring
- 3 Teflon® Back-up Rings
- 4 Bonnet Lock Pin
- 5 Valve Stem
- 6 Valve Bonnet
- 7 Dust Cap
- 8 Valve Handle
- 9 Set Screw

402-404 Hard Seat Technical Data:

Maximum Pressure Rating:	Orifice size:	0.187"
Steel: 10000 psi	Flow Coefficient:	0.44
Stainless Steel: 10000 psi	Standard O-Ring:	Viton®
	Standard Back-up Ring:	Teflon®

406-412 Hard Seat Technical Data:

Maximum Pressure Rating:	Orifice size:	0.438"
Steel: 10000 psi	Flow Coefficient:	2.70
Stainless Steel: 10000 psi	Standard O-Ring:	Viton®
	Standard Back-up Ring:	Teflon®

For flow characteristics refer to page 14

Kalrez® and Viton® are registered trademarks of DuPont Dow Elastomers
Teflon® is a registered trademark of the DuPont Company

500 SERIES soft seat VALVES



A precision molded, replaceable delrin soft seat is the key to the bubble tight seal of the Soft Seat Valve. Typically used in gaseous application, this valve will provide years of dependable, trouble free service.

- Soft seat design is 100% Helium leak tested to 1×10^{-4} ml/s.
- 6,000 psi pressure rating (@200°F maximum).
- Replaceable Delrin seat.
- Straight through porting for bi-directional, high capacity flow and easy roddable cleaning.
- Blow out proof stem that provides a secondary stem seal in the full open position.
- Stem packing below the threads prevents thread galling & contamination.
- Viton O-Ring & Teflon back-up ring stem seals.
- All 316SS stems (even in steel valves) for longer life.
- Stem and bonnet threads are rolled for greater strength and smoother operation.
- One piece bonnet with a metal to metal seal to the valve body below the bonnet threads.
- Bonnet lock pin to prevent accidental loosening.
- Vinyl bonnet & stem dust cap.
- .187 inch orifice size.
- Optional panel mount bonnet and panel nuts.
- Electroless Nickel plated finish on carbon steel valves.
- Electropolish finish on stainless steel valves.

Ordering Information

PART NUMBER	CONNECTION	MATERIAL
502 MFC	1/4 NPT Male-Female	Steel
504 MFC	1/2 NPT Male-Female	Steel
50402 MFC	1/2 NPT Male-1/4 NPT Female	Steel
502 MFS	1/4 NPT Male-Female	Stainless Steel
504 MFS	1/2 NPT Male-Female	Stainless Steel
502 FFC	1/4 NPT Female-Female	Steel
503 FFC	3/8 NPT Female-Female	Steel
504 FFC	1/2 NPT Female-Female	Steel
502 FFS	1/4 NPT Female-Female	Stainless Steel
503 FFS	3/8 NPT Female-Female	Stainless Steel
504 FFS	1/2 NPT Female-Female	Stainless Steel

When ordering options please refer to the Part Number Construction guide below for the appropriate suffix. Please note that the standard O-Ring in all the **NOSHOK** Valves are Viton® and the standard handles are: "T" handles.

Part Number Construction: **504 FFC - PM2 - KZ1 - HL5**

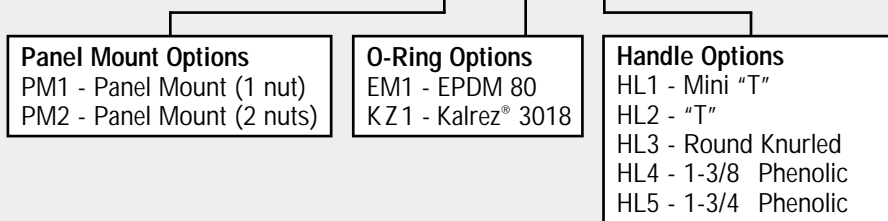

General Dimensions

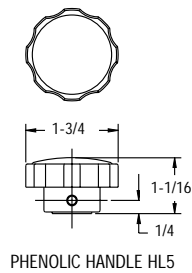
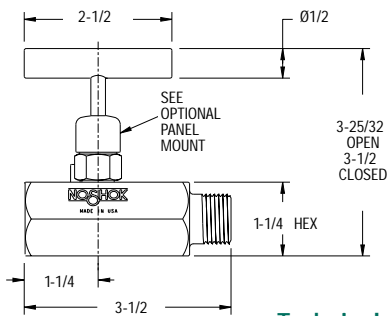
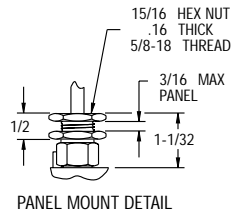
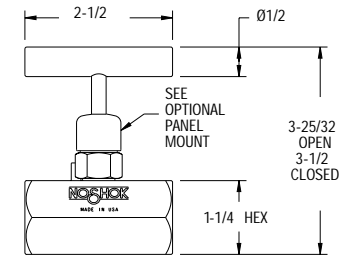

Technical Data:

Maximum Pressure Rating:	Orifice size:	0.187"
Steel: 6000 psi	Flow Coefficient:	0.76
Stainless Steel: 6000 psi	Standard O-Ring:	Viton®
	Standard Back-up Ring:	Teflon®

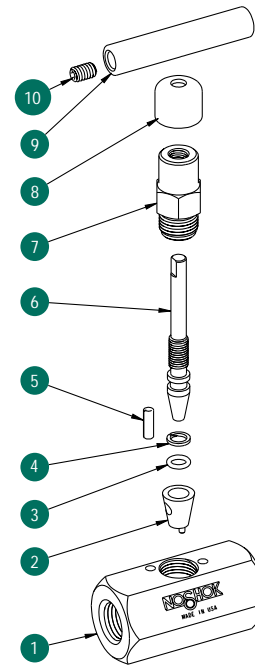

- 1 Valve Body
- 2 Delrin Seat
- 3 Viton® O-Ring
- 4 Teflon® Back-up Ring
- 5 Bonnet Lock Pin
- 6 Valve Stem
- 7 Valve Bonnet
- 8 Dust Cap
- 9 Valve "T" Handle
- 10 Handle Set Screw

For flow characteristics refer to page 14

Kalrez® and Viton® are registered trademarks of DuPont Dow Elastomers
Teflon® is a registered trademark of the DuPont Company

600&700 SERIES

block & bleed VALVES

HARD & SOFT SEAT



NOSHOK Block & Bleed Valves allow pressure to be bled off without disturbing the permanent piping installation thereby enabling the user to quickly and easily remove and/or replace instruments.

HARD SEAT VALVE FEATURES

- Metal to metal hard seat design is 100% Helium leak tested to 1×10^{-4} ml/s at 200 psi.
- 10,000 psi pressure rating (@ 200°F maximum)

SOFT SEAT VALVE FEATURES

- Soft seat design is 100% Helium leak tested to 1×10^{-4} ml/s at 200 psi.
- 6,000 psi pressure rating (@ 200°F maximum)
- Replaceable Delrin seat.
- Straight through porting for bi-directional, high capacity flow and easy roddable cleaning.

STANDARD FEATURES FOR HARD SEAT and SOFT SEAT VALVES

- Blow-out proof stem that provides a secondary stem seal in the full open position.
- Stem packing below the threads prevents thread galling and contamination.
- Viton® O-Ring & Teflon® back-up ring stem seals.
- All 316SS stems (even in steel valves) for longer life.
- Stem and bonnet threads are rolled for greater strength and smoother operation.
- One piece bonnet with a metal to metal seal to the valve body below the bonnet threads.
- Bonnet lock pin to prevent accidental loosening.
- Vinyl bonnet and stem dust cap.
- .187 inch orifice size.
- Optional panel mount bonnet and panel nuts.
- Electroless Nickel plated finish on carbon steel valves.
- Electropolish finish on stainless steel valves.

Ordering Information

600 SERIES - HARD SEAT BLOCK & BLEED VALVES

PART NUMBER	CONNECTION	MATERIAL
602 MFC	1/4 NPT Male-Female	Steel
604 MFC	1/2 NPT Male-Female	Steel
602 MFS	1/4 NPT Male-Female	Stainless Steel
604 MFS	1/2 NPT Male-Female	Stainless Steel
602 FFC	1/4 NPT Female-Female	Steel
604 FFC	1/2 NPT Female-Female	Steel
602 FFS	1/4 NPT Female-Female	Stainless Steel
604 FFS	1/2 NPT Female-Female	Stainless Steel

700 SERIES - SOFT SEAT BLOCK & BLEED VALVES

PART NUMBER	CONNECTION	MATERIAL
702 MFC	1/4 NPT Male-Female	Steel
704 MFC	1/2 NPT Male-Female	Steel
702 MFS	1/4 NPT Male-Female	Stainless Steel
704 MFS	1/2 NPT Male-Female	Stainless Steel
702 FFC	1/4 NPT Female-Female	Steel
704 FFC	1/2 NPT Female-Female	Steel
702 FFS	1/4 NPT Female-Female	Stainless Steel
704 FFS	1/2 NPT Female-Female	Stainless Steel

NACE MRO175-99 CERTIFICATION (Consult Factory)

When ordering options please refer to the Part Number Construction guide below for the appropriate suffix. Please note that the standard O-Ring in all the **NOSHOK** Valves are Viton® and the standard handles are: "T" handles.

Part Number Construction: **702 FFC - PM2 - EM1 - HL5**

Panel Mount Options

PM1 - Panel Mount (1 nut)
PM2 - Panel Mount (2 nuts)

O-Ring Options

EM1 - EPDM 80
KZ1 - Kalrez® 3018

Handle Options

HL1 - Mini "T"
HL2 - "T"
HL3 - Round Knurled
HL4 - 1-3/8 Phenolic
HL5 - 1-3/4 Phenolic

General Dimensions

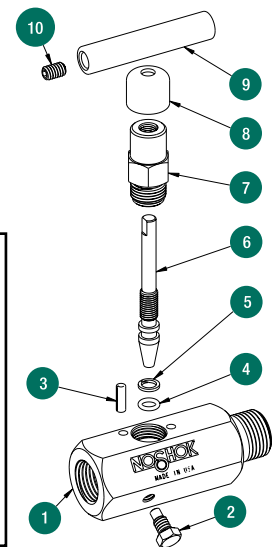
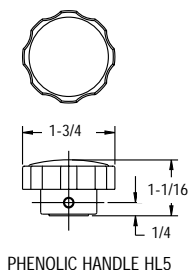
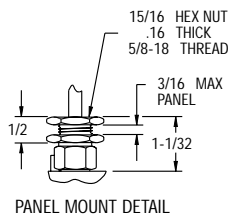
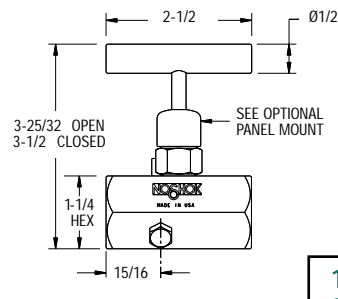
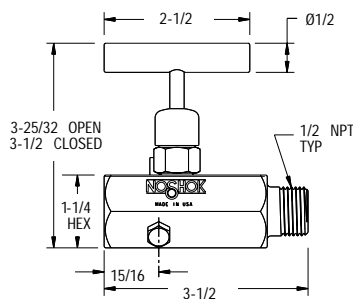

- 1 Valve Body
- 2 Bleed Screw
- 3 Bonnet Lock Pin
- 4 Viton® O-Ring
- 5 Teflon® Back-up Ring
- 6 Valve Stem
- 7 Valve Bonnet
- 8 Dust Cap
- 9 Valve "T" Handle
- 10 Handle Set Screw

Hard Seat Technical Data:

Maximum Pressure Rating: Orifice size: 0.187"
Steel: 10000 psi Flow Coefficient: 0.44
Stainless Steel: 10000 psi Standard O-Ring: Viton®
Standard Back-up Ring: Teflon®

Soft Seat Technical Data:

Maximum Pressure Rating: Orifice size: 0.187"
Steel: 6000 psi Flow Coefficient: 0.76
Stainless Steel: 6000 psi Standard O-Ring: Viton®
Standard Back-up Ring: Teflon®

For flow characteristics refer to page 14

Kalrez® and Viton® are registered trademarks of DuPont Dow Elastomers
Teflon® is a registered trademark of the DuPont Company

FLOW CHARACTERISTICS

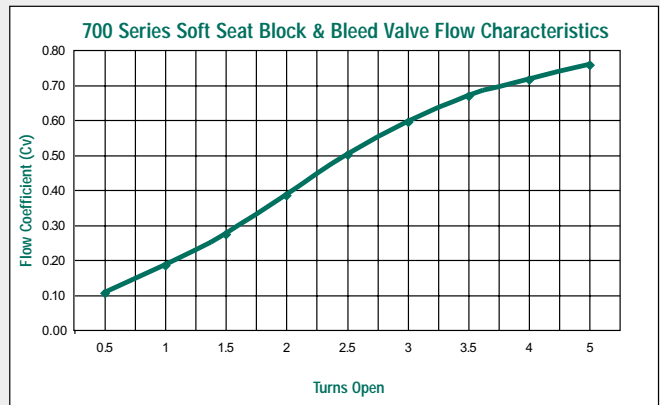
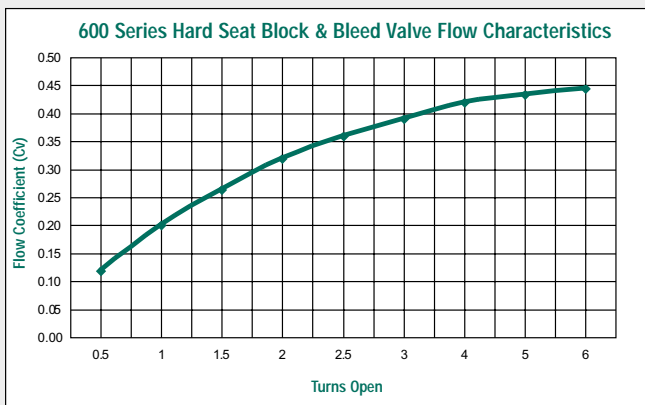
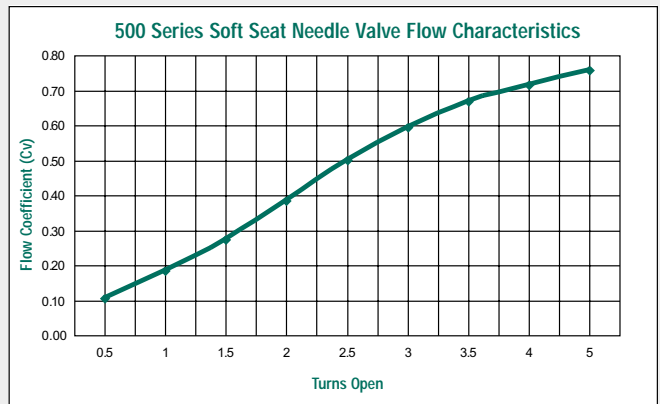
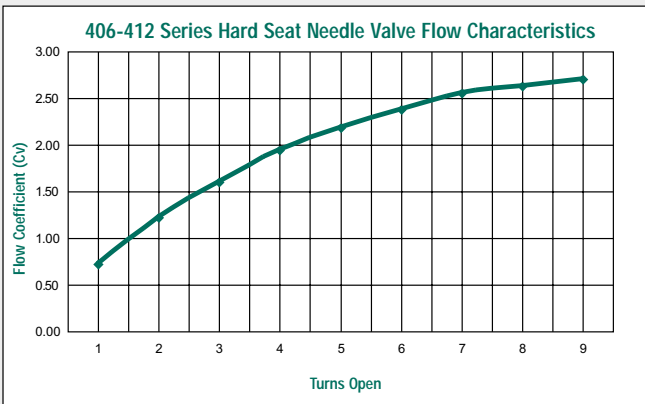
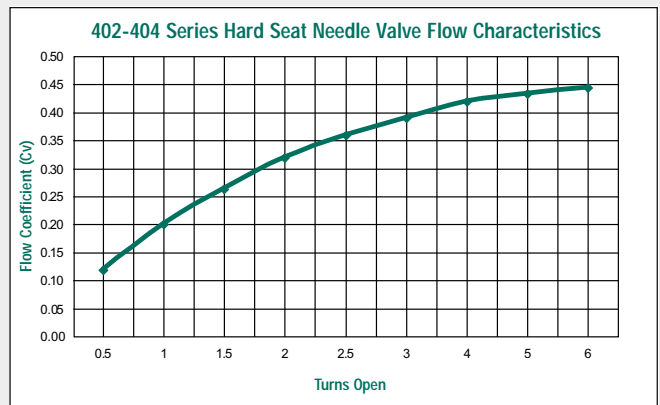
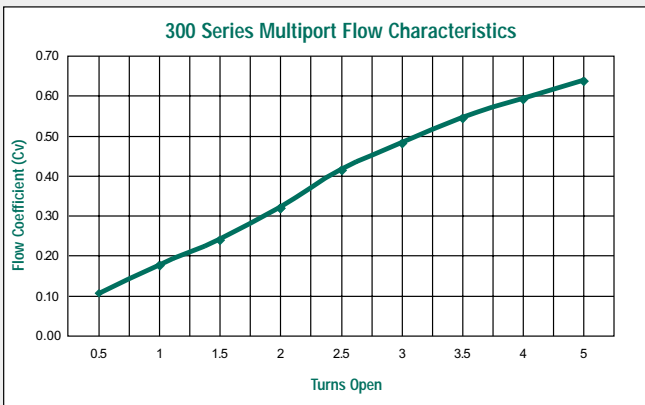
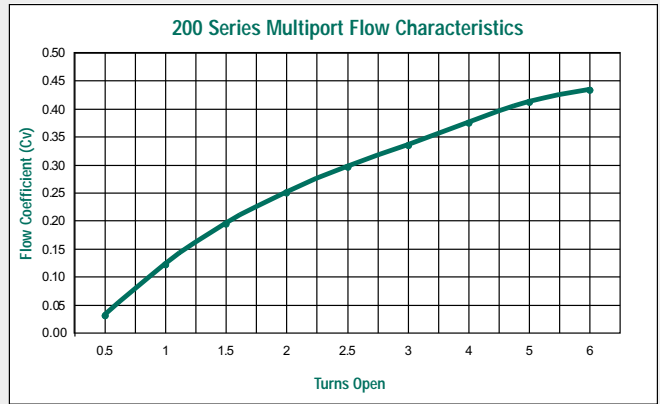
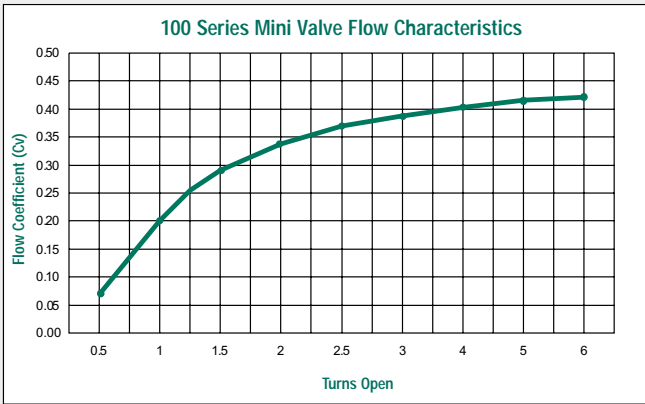

CORPORATE HEADQUARTERS

1010 WEST BAGLEY ROAD • BEREA, OH 44017
440-243-0888 • FAX 440-243-3472

E-MAIL: noshok@noshok.com
WEB: www.noshok.com

