

SAE Flanges



Gear Pump Flanges



Germany

Walter Stauffenberg GmbH & Co. KG

Im Ehrenfeld 4

58791 Werdohl

Tel.: +49 2392 91 60

Fax: +49 2392 91 61 60

E-Mail: sales@stauff.com

www.stauff.com

STAUFF products and services are globally available through wholly-owned subsidiaries and a tight network of authorised distributors and representatives in all major industrial regions of the world.

You can find detailed contact information on the last two pages of this product catalogue or at www.stauff.com.

Please note: Unless otherwise stated, all data and figures in this product catalogue are approximate values and are only valid as references, which are not binding (also in respect to any third parties' rights of protection) and thus do not release the customer / user from checking and testing the suitability of the products for the foreseen purposes. Therefore, data and figures can only be used in a limited sense for construction purposes.

The application of the products is beyond the control possibilities of the manufacturer and, therefore, is exclusively subject to the responsibility of the customer / user.

In the event that a liability is nevertheless considered, any compensation will be limited to the value of the goods supplied by the manufacturer and used by the customer / user. As a matter of course, the manufacturer guarantees the perfect quality of all products in accordance with the General Terms and Conditions of Business and Sale.

Subject to modifications due to the ongoing development and improvement of the products.

With the publication of this product catalogue, previous editions are no longer valid.

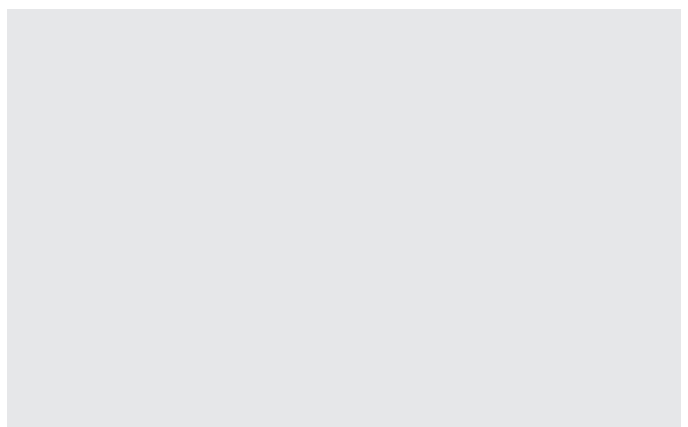
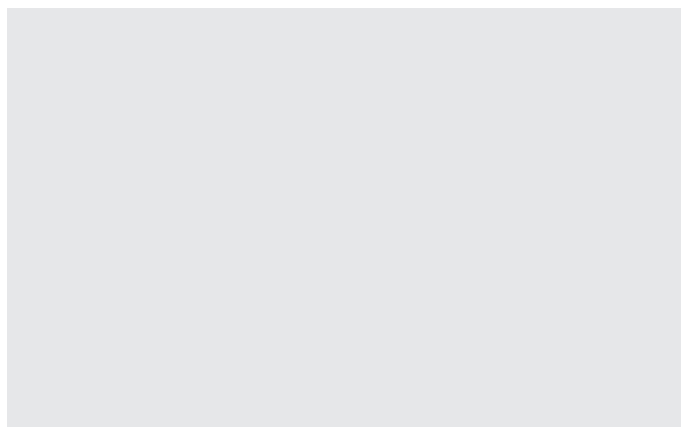

Introduction	4 - 11	
SAE Split Flange Halves / Flange Clamps	12 - 21	A
SAE Flange / Counterflange Adaptors	22 - 37	B
SAE Single-Part Flanges / Counterflanges	38 - 79	C
Accessories for SAE Flanges	80 - 89	D
SAE Flange Blocks	90 - 97	E
Gear Pump Flanges	98 - 111	F
Assembly Instructions	112 - 117	G
Appendix (Product-Specific Abbreviations / Global Contact Directory)	118 - 123	





**Catalogue 1
STAUFF Clamps**

- Block Clamps
- Special Clamps
- Light Series Clamps
- Saddle Clamps
- U-Bolt Clamps
- Metal Clamps
- Construction Series

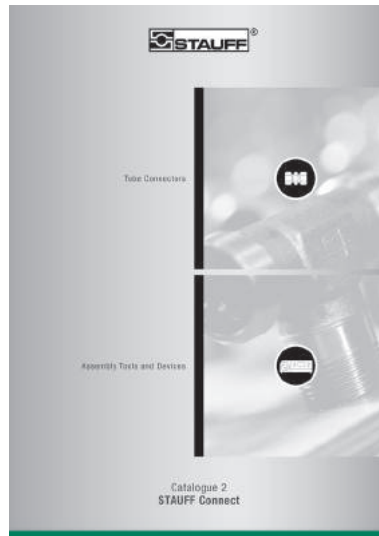

**Catalogue 2
STAUFF Connect**

- Tube Connectors
- Assembly Tools and Devices

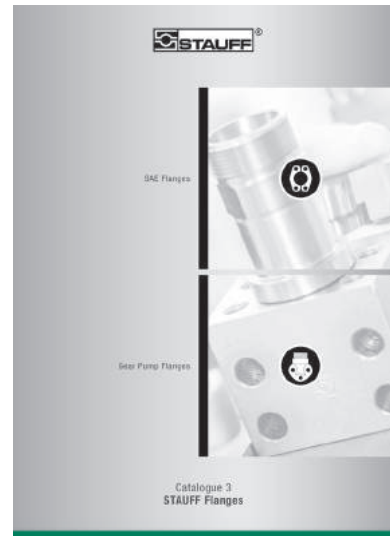

**Catalogue 3
STAUFF Flanges**

- SAE Flanges
- Gear Pump Flanges



**Catalogue 4
VOSWINKEL
Hose Connectors**

- Hose Connectors
- High-Pressure Hose Connectors

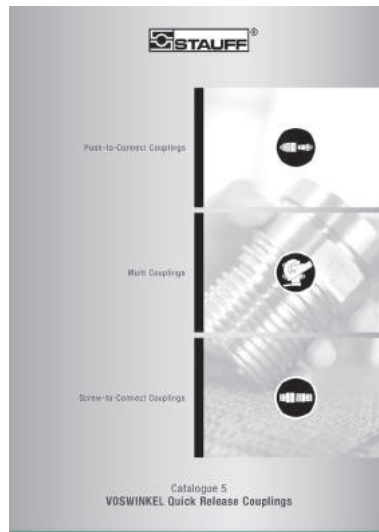

**Catalogue 5
VOSWINKEL
Quick Release Couplings**

- Push-to-Connect Couplings
- Multi Couplings
- Screw-to-Connect Couplings



**Catalogue 6
STAUFF Valves**

- Two-Way Ball Valves
- Multi-Way Ball Valves
- Flow Control and Check Valves
- Gauge Isolator Valves





Catalogue 7 STAUFF Test

- Test Couplings
- Test Adaptors
- Test Hoses and Connectors



Catalogue 8 STAUFF Diagtronics

- Pressure Gauges
- Hydraulic Testers
- Oil Analysis Equipment



Catalogue 9 STAUFF Filtration Technology

- Replacement Filter Elements
- Pressure Filters
- Return-Line Filters
- In-Line Filters
- Spin-On Filters
- Offline and Bypass Filters
- Filtration Systems

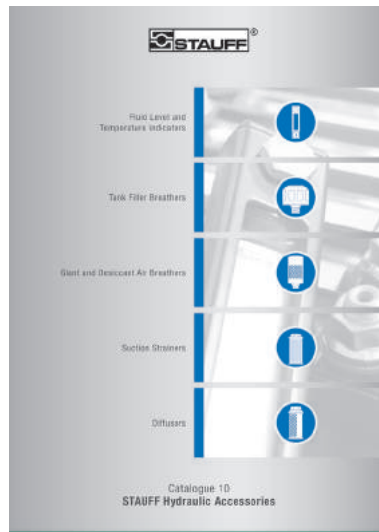

Catalogue 10 STAUFF Hydraulic Accessories

- Fluid Level and Temperature Indicators
- Tank Filler Breathers
- Giant and Desiccant Air Breathers
- Suction Strainers
- Diffusers



For more than 50 years, the companies of STAUFF Group have been developing, manufacturing and distributing pipework equipment and hydraulic components for mechanical and plant engineering and for service and industrial maintenance.

In addition to mobile and industrial hydraulic machinery, typical applications also include commercial and special purpose vehicles, rail transportation and energy technology. Likewise, STAUFF products are used in marine, oil and gas applications and in the process, food and chemical industries.

The overall range currently includes about 40000 standard products as well as numerous special and system solutions according to customer's specifications or based on our in-house development.

All STAUFF products undergo relevant testing in accordance with international regulations and are governed by the high standards of the in-house quality management system. Furthermore, many items have received certifications and approvals from various international institutes, organisations and authorities who have independently confirmed the quality and performance of the products.

Wholly-owned manufacturing, sales and service facilities in 18 countries and a tight global network of authorised distribution partner ensure high presence and service paired with a maximum of availability.



Quality Management – ISO 9001:2015
Environmental Management – ISO 14001:2015
Safety Management OHSAS – 18001:2007

STAUFF LINE Components

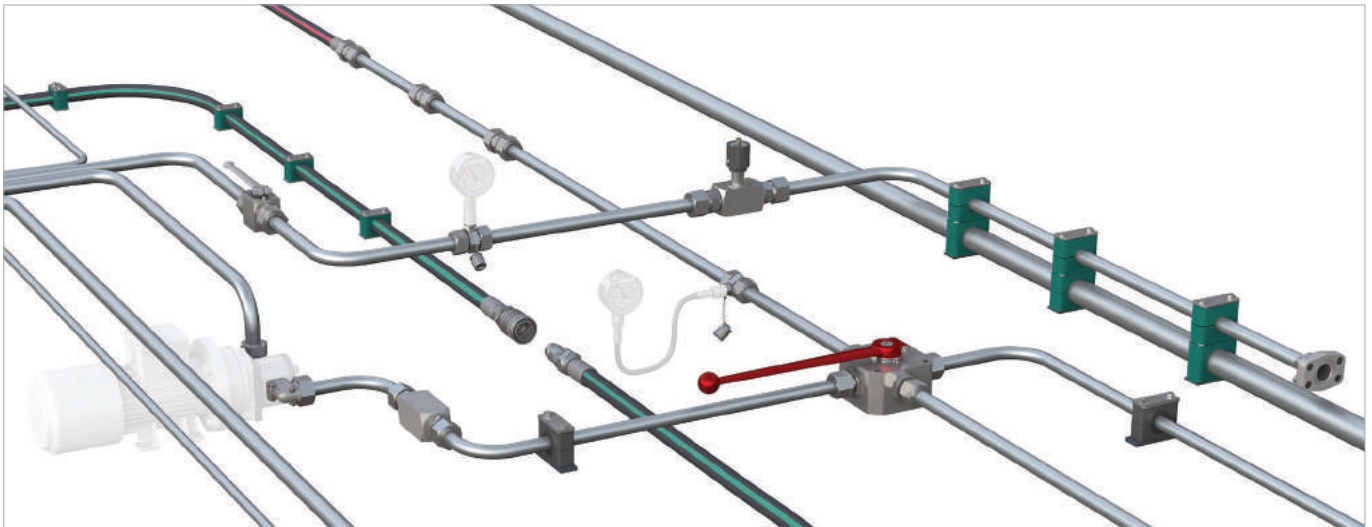

With the seven dedicated **STAUFF Line** product groups

- **STAUFF Clamps**
- **STAUFF Connect**
- **STAUFF Flanges**
- **VOSWINKEL Hose Connectors**
- **VOSWINKEL Quick Release Couplings**
- **STAUFF Valves**
- **STAUFF Test**

from own, in-house development and manufacturing, the companies of the STAUFF Group provide a comprehensive range of components for fastening and connecting pipes, tubes and hoses for mobile and industrial hydraulic applications and many other industries.

The portfolio is completed by components for shutting-off, regulating, throttling and measuring fluid media.

In order to perfectly match each other, STAUFF Line products are designed and offered on a high, uniform level of quality. A large proportion of the range made from steel comes as standard with the premium STAUFF Zinc/Nickel surface coating, which is also optionally available for many of the other components.

This coating offers the most reliable surface protection far beyond the previous market standards – even after transport, handling and assembly of the components – and meets all current legal requirements.

If desired, Original Equipment Manufacturers can be supported with value-added services, from **technical consultation to pre-assembly, assembly and kitting** as well as **logistics services**:

- Support with the **selection of suitable standard components** and ordering options; provision of **customised solutions** according to customer's specifications or based on our in-house development – from prototyping to large scale production
- **Analysis and optimization** of existing and design and developments of new systems aimed at increasing the efficiency and performance of machines and equipment and creating value for customers by reducing the total cost
- **Pre-assembly, assembly and kitting** of individual components to customer-specific system modules
- Individually coordinated **procurement solutions** (e.g. web shop and electronic data interchange) and **supply models** (e.g. from warehousing of customised components to Kanban logistics and just-in-time delivery of pre-fabricated system modules to the assembly lines of the customers) aimed at optimising material flows



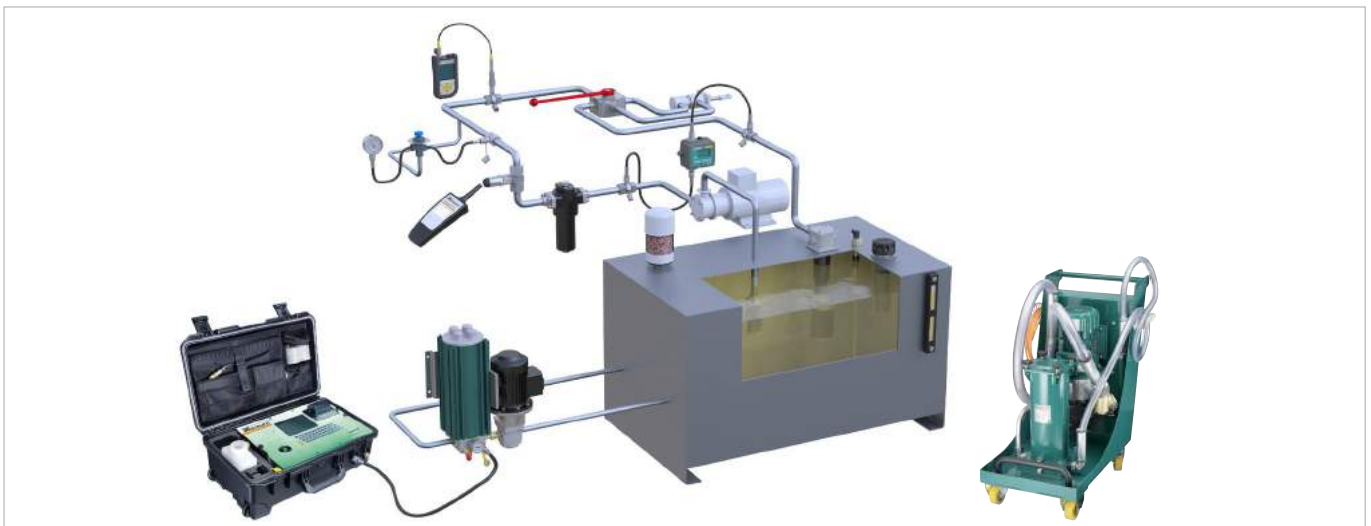

Aligned with the needs of the market, the product groups

- **STAUFF Test**
- **STAUFF Diagtronics**
- **STAUFF Filtration Technology**
- **STAUFF Hydraulic Accessories**

include a comprehensive range of analogue and digital measuring equipment and devices, filtration systems and replacement filter elements as well as accessories for the construction of tanks, reservoirs, power packs and gear boxes in mobile and industrial hydraulics.

The offer is completed by relevant value-added services:

- Support with the **selection of suitable components** and ordering options; provision of **customised solutions** according to customer's specifications or based on our in-house development – from prototyping to large scale production
- Analysis of existing hydraulic circuits aimed at filtration systems, tank components and monitoring devices that perfectly match to the specific requirements, and developing integrated concepts to increase the efficiency and performance of machines and equipment
- Individually coordinated **procurement solutions** and **supply models**





STAUFF Flanges

The STAUFF Flanges product group is closely aligned with the market requirements and contains an extensive range of single-part and multi-part SAE flange connectors in the standard and high pressure series according to SAE J 518 C and ISO 6162-1/2.

The standard-Pressure Series (3000 PSI) contains flange components with maximum operating pressures between 35 bar and 350 bar or 508 PSI and 5075 PSI and is available for a variety of nominal sizes between DN 13 (1/2") and DN 127 (5").

The 6.000 PSI High-Pressure Series is suitable for maximum operating pressures up to 400 bar or 6090 PSI and covers nominal sizes between DN 13 (1/2") and DN 76 (3"),

STAUFF SAE Flanges are used as a reliable alternative in applications where the use of regular tube fittings is not permitted or technically not possible due to the required operating pressure, the size or the limited mounting space.

Compared to tube fittings, the biggest advantage of SAE Flanges is the considerably higher pressure resistance for most sizes and the continuous pressure level in the High-Pressure Series (6000 PSI).

The STAUFF Flanges product group is completed by various types and designs of gear pump flanges made from carbon steel and aluminium in accordance with German and Italian connection standards.







www.stauff.com/catalogues

The STAUFF online catalogue centre at www.stauff.com/catalogues provides fast and direct access to digital versions of this as well as other STAUFF product catalogues in all available languages.

Online Page-Flip Catalogues

- Easy navigation through index or the powerful full text search functionality
- Contents can be shared and forwarded by e-mail, printed or downloaded and saved in PDF file format
- Also suitable for mobile devices

Download Catalogues

- Download entire product catalogues and save them in PDF file format

Catalogue Request

- Contact form to request printed copies of the product catalogue as well as digital copies on CD-ROM or USB stick

The fastest way to the online page-flip catalogue:

The links that can be found at the bottom edge of all pages of this product catalogue will lead you directly to the corresponding page in the online page-flip catalogue.

In doing so, contents can be searched, shared and forwarded by e-mail, printed or downloaded and saved in PDF file format.

Scan the QR code next to the direct link with the camera of your mobile device* and also use the functions in this way.

* may require a suitable app





www.stauff.com

General information about the companies of STAUFF Group, latest business and product news as well as complete global contact details

www.stauff.com/cad

Immediate access to and free download of 3D models and 2D drawings for a growing number of STAUFF products

www.filterinterchange.com

Online database for the quick and easy identification and interchange of almost all common brands and types of replacement filter elements

Follow STAUFF and keep yourself updated:

Facebook
www.facebook.com/stauffgroup



Twitter
www.twitter.com/stauffgroup

LinkedIn
www.linkedin.com/company/stauff

Youtube
www.youtube.com/stauffgroup





	SAE Split Flange Halves DB	14
	SAE Flange Clamp BM	16
	SAE Split Flange Halves (Flat Style) DB-FL	18
	SAE Flange Clamp (Flat Style) BM-FL	19
	SAE Flange Clamp with Metric Tapped Holes BM-G	20



SAE Split Flange Halves
Type DB - 3000 PSI Series

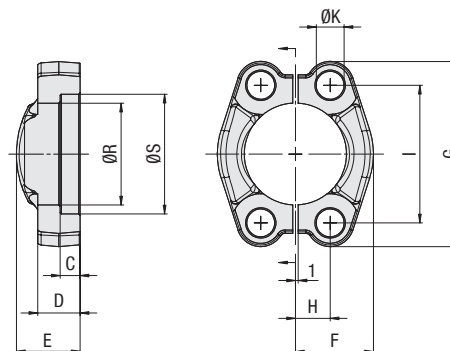

3000 PSI Standard Pressure Series (according to ISO 6162-1:2002)

Nominal Size	DN	(in)	PN ¹ (bar/PSI)		Dimensions (mm/in)								Weight (kg/lbs) ca.	for Bolts		Ordering Codes		
			8.8	10.9 (MH)	ØR	ØS	C	D	E	F	G	H		I	ØK ²		per 100	Metric
13	1/2		350	350	24,3	31	6,2	13	19	22,8	54	8,75	38,1	8,7	13,20	M8x25	5/16-18 UNC x 1-1/4	DB-301-W66
			5075	5075	.96	1.22	.24	.51	.75	.90	2.13	.34	1.50	.34	29.04			
19	3/4		350	350	32,2	38,9	6,2	14	22	25,9	65	11,15	47,6	10,5	17,00	M10x30	3/8-16 UNC x 1-1/4	DB-302-W66
			5075	5075	1.27	1.53	.24	.55	.87	1.02	2.56	.44	1.87	.41	37.40			
25	1		250	315	38,5	45,3	7,5	16	24	29,2	70	13,1	52,4	10,5	22,00	M10x30	3/8-16 UNC x 1-1/4	DB-303-W66
			3625	4568	1.52	1.78	.30	.63	.94	1.15	2.76	.52	2.06	.41	48.40			
32	1-1/4		200	250	43,7	51,6	7,5	14	22	36,3	79,5	15,1	58,7	12	30,00		7/16-14 UNC x 1-1/2	DB-304-U-W66
			2900	3625	1.72	2.03	.30	.55	.87	1.43	3.13	.59	2.31	.47	66.00			
32	1-1/4		200	250	43,7	51,6	7,5	14	22	36,3	79,5	15,1	58,7	12,5	31,20	M12x35		DB-304-M12-W66
			2900	3625	1.72	2.03	.30	.55	.87	1.43	3.13	.59	2.31	.49	68.64			
32	1-1/4		200	250	43,7	51,6	7,5	14	22	36,3	79,5	15,1	58,7	10,5	32,20	M10x30		DB-304-M-W66
			2900	3625	1.72	2.03	.30	.55	.87	1.43	3.13	.59	2.31	.41	70.84			
38	1-1/2		200	200	50,8	61,1	7,5	16	25	41,1	94	17,85	69,9	13,5	47,00	M12x35	1/2-13 UNC x 1-1/2	DB-305-W66
			2900	2900	2.00	2.41	.30	.63	.98	1.62	3.70	.70	2.75	.53	103.40			
38	1-1/2		200	200	50,8	61,1	7,5	16	25	41,1	94	17,85	69,9	15	46,00	M14x35		DB-305-M14-W66
			2900	2900	2.00	2.41	.30	.63	.98	1.62	3.70	.70	2.75	.59	101.20			
51	2		160	200	62,8	72,3	9	16	26	48,2	102	21,45	77,8	13,5	54,20	M12x35	1/2-13 UNC x 1-1/2	DB-306-W66
			2320	2900	2.47	2.85	.35	.63	1.02	1.90	4.02	.84	3.06	.53	119.24			
51	2		160	200	62,8	72,3	9	16	26	48,2	102	21,45	77,8	15	50,00	M14x35		DB-306-M14-W66
			2320	2900	2.47	2.85	.35	.63	1.02	1.90	4.02	.84	3.06	.59	110.00			
64	2-1/2		100	160	74,9	84,9	9	19	38	54,1	114,5	25,4	88,9	13,5	90,30	M12x40	1/2-13 UNC x 1-1/2	DB-307-W66
			1450	2320	2.95	3.34	.35	.75	1.50	2.13	4.51	1.00	3.50	.53	198.66			
64	2-1/2		100	160	74,9	84,9	9	19	38	54,1	114,5	25,4	88,9	15	74,00	M14x40		DB-307-M14-W66
			1450	2320	2.95	3.34	.35	.75	1.50	2.13	4.51	1.00	3.50	.59	162.80			
76	3		100	160	90,9	102,4	9	22	41	65,3	135	30,95	106,4	17	135,60	M16x50	5/8-11 UNC x 2	DB-308-W66
			1450	2320	3.58	4.03	.35	.87	1.61	2.57	5.31	1.22	4.19	.67	298.32			
89	3-1/2		35	35	102,4	115,1	10,7	22	28	69,6	152	34,95	120,7	17	135,00	M16x50	5/8-11 UNC x 2	DB-309-W66
			508	508	4.03	4.53	.42	.87	1.10	2.74	5.98	1.38	4.75	.67	297.00			
102	4		35	35	115	127,8	10,7	25	35	75,9	162	38,9	130,2	17	170,00	M16x50	5/8-11 UNC x 2	DB-310-W66
			508	508	4.53	5.03	.42	.98	1.38	2.99	6.38	1.53	5.13	.67	374.00			
127	5		35	35	140,5	153,2	10,7	28	41	90,4	184	46,5	152,4	17	246,80	M16x55	5/8-11 UNC x 2-1/4	DB-311-W66
			508	508	5.53	6.03	.42	1.10	1.61	3.56	7.24	.00	6.00	.67	542.96			

Materials / Ordering Options / Examples

- * Pair of SAE Split Flange Halves made of Steel S355J0 / C45 or equivalent, zinc-plated and thick-film-passivated **DB-...-W66**
- * Pair of SAE Split Flange Halves made of Steel S355J0 / C45 or equivalent, zinc/nickel-plated (on request) **DB-...-W3**
- * Pair of SAE Split Flange Halves made of Stainless Steel V4A - 1.4404 (on request) **DB-...-W5**
- * Kit including Metric bolts 8.8, spring rings, O-ring made of NBR (Buna-N®) **DB-...-M-B-W66-K**
- * Kit including Metric bolts 8.8, spring rings, O-ring made of FKM/FPM (Viton®) **DB-...-M-V-W66-K**
- * Kit including Metric bolts 10.9, spring rings, O-ring made of NBR (Buna-N®) **DB-...-MH-B-W129-K**
- * Kit including UNC bolts (Grade 8), spring rings, O-ring made of NBR (Buna-N®) **DB-...-U-B-W129-K**

¹ The maximum working pressure PN (bar/PSI) applies only to the flange itself and depends on the bolts used (Grade 8.8 / 10.9). The actual maximum working pressure depends on the thickness and the quality of the tube used.

² Dimensions of screw holes in part different to the ISO to match both Metric and UNC bolts.



SAE Split Flange Halves
Type DB • 6000 PSI Series

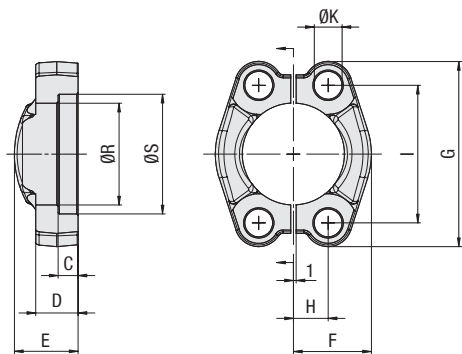

A

6000 PSI High Pressure Series (according to ISO 6162-2:2002)

Nominal Size	DN	(in)	PN ¹ (bar/PSI)		Dimensions (mm/in)										Weight (^{kg} /lbs) ca.		for Bolts		Ordering Codes
			8.8	10.9 (MH)	ØR	ØS	C	D	E	F	G	H	I	ØK ²	per 100	Metric	UNC		
13	1/2		350	420	24,6	32,5	7,2	16	22	23,6	56,5	9,10	40,5	8,7	16,70	M8x30	5/16-18 UNC x 1-1/4	DB-601-W66	
			5075	6090	.97	1.28	.28	.63	.87	.93	2.22	.36	1.59	.34	36.74				
19	3/4		350	420	32,5	42	8,2	19	28	30	71	11,90	50,8	10,5	33,20	M10x35	3/8-16 UNC x 1-1/2	DB-602-W66	
			5075	6090	1.28	1.65	.32	.75	1.10	1.18	2.80	.47	2.00	.41	73.04				
25	1		350	420	38,8	48,4	9	24	33	34,8	81	13,90	57,2	11,9	51,30	M12x45	7/16-14 UNC x 1-3/4	DB-603-U-W66	
			5075	6090	1.53	1.91	.35	.94	1.30	1.37	3.19	.55	2.25	.47	112.86				
25	1		350	420	38,8	48,4	9	24	33	34,8	81	13,90	57,2	13	52,20	M12x45		DB-603-M-W66	
			5075	6090	1.53	1.91	.35	.94	1.30	1.37	3.19	.55	2.25	.51	114.84				
32	1-1/4		350	420	44,5	54,8	9,8	27	38	38,6	95	15,90	66,6	13,5	83,70	M12x45	1/2-13 UNC x 1-3/4	DB-604-W66	
			5075	6090	1.75	2.16	.39	1.06	1.50	1.52	3.74	.63	2.62	.53	184.14				
32	1-1/4		350	420	44,5	54,8	9,8	27	38	38,6	95	15,90	66,6	15	80,00	M14x45		DB-604-M14-W66	
			5075	6090	1.75	2.16	.39	1.06	1.50	1.52	3.74	.63	2.62	.59	176.00				
38	1-1/2		350	420	51,6	64,3	12	30	43	47,5	113	18,25	79,3	17	135,00	M16x55	5/8-11 UNC x 2-1/4	DB-605-W66	
			5075	6090	2.03	2.53	.47	1.18	1.69	1.87	4.45	.72	3.12	.67	297.00				
51	2		350	420	67,6	80,2	12	37	52	56,9	133	22,25	96,8	21	210,00	M20x70	3/4-10 UNC x 2-3/4	DB-606-W66	
			5075	6090	2.66	3.16	.47	1.46	2.05	2.24	5.24	.88	3.81	.83	462.00				

¹ The maximum working pressure PN (bar/PSI) applies only to the flange itself and depends on the bolts used (Grade 8.8 / 10.9). The actual maximum working pressure depends on the thickness and the quality of the tube used.

² Dimensions of screw holes in part different to the ISO to match both Metric and UNC bolts.

Materials / Ordering Options / Examples

- * Pair of SAE Split Flange Halves made of Steel S355J0 / C45 or equivalent, zinc-plated and thick-film-passivated **DB-...-W66**
- * Pair of SAE Split Flange Halves made of Steel S355J0 / C45 or equivalent, zinc/nickel-plated (on request) **DB-...-W3**
- * Pair of SAE Split Flange Halves made of Stainless Steel V4A – 1.4404 (on request) **DB-...-W5**

- * Kit including Metric bolts 8.8, spring rings, O-ring made of NBR (Buna-N®) **DB-...-M-B-W66-K**
- * Kit including Metric bolts 8.8, spring rings, O-ring made of FKM/FPM (Viton®) **DB-...-M-V-W66-K**

- * Kit including Metric bolts 10.9, spring rings, O-ring made of NBR (Buna-N®) **DB-...-MH-B-W129-K**
- * Kit including UNC bolts (Grade 8), spring rings, O-ring made of NBR (Buna-N®) **DB-...-U-B-W129-K**



SAE Flange Clamp
Type BM - 3000 PSI Series

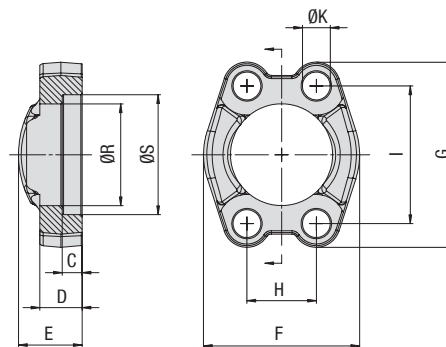

3000 PSI Standard Pressure Series (according to ISO 6162-1:2002)

Nominal Size	DN	(in)	PN ¹		Dimensions											Weight		for Bolts		Ordering Codes
			(bar/PSI)	(MH)	(mm/in)											(kg/lbs) ca.	Metric	UNC		
			8.8	10.9 (MH)	ØR	ØS	C	D	E	F	G	H	I	ØK ²						
13	1/2	350	350	24,3	31	6,2	13	19	46	54	17,5	38,1	8,7	13,7	M8x25	5/16-18 UNC x 1-1/4	BM-301-W66			
		5075	5075	.96	1.22	.24	.51	.75	1.81	2.13	.69	1.50	.34	30.14						
19	3/4	350	350	32,2	38,9	6,2	14	22	52	65	22,3	47,6	10,5	20,1	M10x30	3/8-16 UNC x 1-1/4	BM-302-W66			
		5075	5075	1.27	1.53	.24	.55	.87	2.05	2.56	.88	1.87	.41	44.22						
25	1	250	315	38,5	45,3	7,5	16	24	59	70	26,2	52,4	10,5	22,9	M10x30	3/8-16 UNC x 1-1/4	BM-303-W66			
		3625	4568	1.52	1.78	.30	.63	.94	2.32	2.76	1.03	2.06	.41	50.38						
32	1-1/4	200	250	43,7	51,6	7,5	14	22	73	79,5	30,2	58,7	12	30,0	M12x35	7/16-14 UNC x 1-1/2	BM-304-U-W66			
		2900	3625	1.72	2.03	.30	.55	.87	2.87	3.13	1.19	2.31	.47	66.00						
32	1-1/4	200	250	43,7	51,6	7,5	14	22	73	79,5	30,2	58,7	12,5	32,3	M12x35		BM-304-M12-W66			
		2900	3625	1.72	2.03	.30	.55	.87	2.87	3.13	1.19	2.31	.49	71.06						
32	1-1/4	200	250	43,7	51,6	7,5	14	22	73	79,5	30,2	58,7	10,5	32,8	M10x30		BM-304-M-W66			
		2900	3625	1.72	2.03	.30	.55	.87	2.87	3.13	1.19	2.31	.41	72.16						
38	1-1/2	200	200	50,8	61,1	7,5	16	25	83	94	35,7	69,9	13,5	48,6	M12x35	1/2-13 UNC x 1-1/2	BM-305-W66			
		2900	2900	2.00	2.41	.30	.63	.98	3.27	3.70	1.41	2.75	.53	106.92						
38	1-1/2	200	200	50,8	61,1	7,5	16	25	83	94	35,7	69,9	15	45,0	M14x35		BM-305-M14-W66			
		2900	2900	2.00	2.41	.30	.63	.98	3.27	3.70	1.41	2.75	.59	99.00						
51	2	160	200	62,8	72,3	9	16	26	97	102	42,9	77,8	13,5	55,6	M12x35	1/2-13 UNC x 1-1/2	BM-306-W66			
		2320	2900	2.47	2.85	.35	.63	1.02	3.82	4.02	1.69	3.06	.53	122.32						
51	2	160	200	62,8	72,3	9	16	26	97	102	42,9	77,8	15	50,0	M14x35		BM-306-M14-W66			
		2320	2900	2.47	2.85	.35	.63	1.02	3.82	4.02	1.69	3.06	.59	110.00						
64	2-1/2	100	160	74,9	84,9	9	19	38	109	114,5	50,8	88,9	13,5	89,7	M12x40	1/2-13 UNC x 1-1/2	BM-307-W66			
		1450	2320	2.95	3.34	.35	.75	1.50	4.29	4.51	2.00	3.50	.53	197.34						
64	2-1/2	100	160	74,9	84,9	9	19	38	109	114,5	50,8	88,9	15	74,0	M14x40		BM-307-M14-W66			
		1450	2320	2.95	3.34	.35	.75	1.50	4.29	4.51	2.00	3.50	.59	162.80						
76	3	100	160	90,9	102,4	9	22	41	131	135	61,9	106,4	17	135,9	M16x50	5/8-11 UNC x 2	BM-308-W66			
		1450	2320	3.58	4.03	.35	.87	1.61	5.16	5.31	2.44	4.19	.67	298.99						
89	3-1/2	35	35	102,4	115,1	10,7	22	28	140	152	69,9	120,7	17	134,1	M16x50	5/8-11 UNC x 2	BM-309-W66			
		508	508	4.03	4.53	.42	.87	1.10	5.51	5.98	2.75	4.75	.67	295.02						
102	4	35	35	115	127,8	10,7	25	35	152	162	77,8	130,2	17	166,0	M16x50	5/8-11 UNC x 2	BM-310-W66			
		508	508	4.53	5.03	.42	.98	1.38	5.98	6.38	3.06	5.13	.67	365.20						
127	5	35	35	140,5	153,2	10,7	28	41	181	184	92,1	152,4	17	253,8	M16x55	5/8-11 UNC x 2-1/4	BM-311-W66			
		508	508	5.53	6.03	.42	1.10	1.61	7.13	7.24	3.63	6.00	.67	558.36						

Materials / Ordering Options / Examples

- * Flange Clamp made of Steel S355J0 / C45 or equivalent, zinc-plated and thick-film-passivated
- * Flange Clamp made of Steel S355J0 / C45 or equivalent, zinc/nickel-plated (on request)
- * Flange Clamp made of Stainless Steel V4A - 1.4404 (on request)

BM-...-W66
BM-...-W3
BM-...-W5

- * Kit including Metric bolts 8.8, spring rings, O-ring made of NBR (Buna-N®)
- * Kit including Metric bolts 8.8, spring rings, O-ring made of FKM/FPM (Viton®)

BM-...-M-B-W66-K
BM-...-M-V-W66-K

- * Kit including Metric bolts 10.9, spring rings, O-ring made of NBR (Buna-N®)
- * Kit including UNC bolts (Grade 8), spring rings, O-ring made of NBR (Buna-N®)

BM-...-MH-B-W129-K
BM-...-U-B-W129-K

¹ The maximum working pressure PN (bar/PSI) applies only to the flange itself and depends on the bolts used (Grade 8.8 / 10.9). The actual maximum working pressure depends on the thickness and the quality of the tube used.

² Dimensions of screw holes in part different to the ISO to match both Metric and UNC bolts.



SAE Flange Clamp
Type BM - 6000 PSI Series

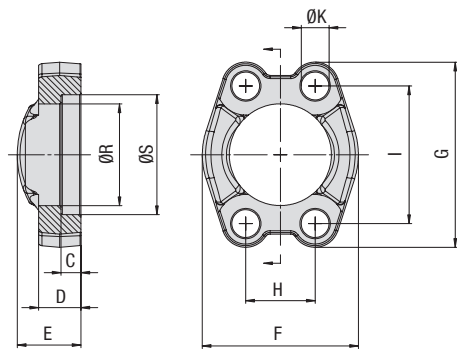

A

6000 PSI High Pressure Series (according to ISO 6162-2:2002)

Nominal Size	DN	(in)	PN ¹ (bar/PSI)		Dimensions (mm/in)										Weight for Bolts (^{kg} /lbs) ca.			Ordering Codes
			8.8	10.9 (MH)	ØR	ØS	C	D	E	F	G	H	I	ØK ²	per 100	Metric	UNC	
13	1/2		350	420	24,6	32,5	7,2	16	22	48	56,5	18,2	40,5	8,7	17,3	M8x30	5/16-18 UNC x 1-1/4	BM-601-W66
			5075	6090	.97	1.28	.28	.63	.87	1.89	2.22	.72	1.59	.34	38.06			
19	3/4		350	420	32,5	42	8,2	19	28	60	71	23,8	50,8	10,5	35,0	M10x35	3/8-16 UNC x 1-1/2	BM-602-W66
			5075	6090	1.28	1.65	.32	.75	1.10	2.36	2.80	.94	2.00	.41	77.00			
25	1		350	420	38,8	48,4	9	24	33	70	81	27,8	57,2	12	57,8	7/16-14 UNC x 1-3/4	BM-603-U-W66	
			5075	6090	1.53	1.91	.35	.94	1.30	2.76	3.19	1.09	2.25	.47	127.16			
25	1		350	420	38,8	48,4	9	24	33	70	81	27,8	57,2	13	55,7	M12x45	BM-603-M-W66	
			5075	6090	1.53	1.91	.35	.94	1.30	2.76	3.19	1.09	2.25	.51	122.54			
32	1-1/4		350	420	44,5	54,8	9,8	27	38	78	95	31,8	66,6	13,5	85,0	M12x45	1/2-13 UNC x 1-3/4	BM-604-W66
			5075	6090	1.75	2.16	.39	1.06	1.50	3.07	3.74	1.25	2.62	.53	187.00			
32	1-1/4		350	420	44,5	54,8	9,8	27	38	78	95	31,8	66,6	15	80,8	M14x45	BM-604-M14-W66	
			5075	6090	1.75	2.16	.39	1.06	1.50	3.07	3.74	1.25	2.62	.59	177.76			
38	1-1/2		350	420	51,6	64,3	12	30	43	95	113	36,5	79,3	17	139,5	M16x55	5/8-11 UNC x 2-1/4	BM-605-W66
			5075	6090	2.03	2.53	.47	1.18	1.69	3.74	4.45	1.44	3.12	.67	306.90			
51	2		350	420	67,6	80,2	12	37	52	114	133	44,5	96,8	21	211,0	M20x70	3/4-10 UNC x 2-3/4	BM-606-W66
			5075	6090	2.66	3.16	.47	1.46	2.05	4.49	5.24	1.75	3.81	.83	464.20			

¹ The maximum working pressure PN (bar/PSI) applies only to the flange itself and depends on the bolts used (Grade 8.8 / 10.9). The actual maximum working pressure depends on the thickness and the quality of the tube used.

² Dimensions of screw holes in part different to the ISO to match both Metric and UNC bolts.

Materials / Ordering Options / Examples

- * Flange Clamp made of Steel S355J0 / C45 or equivalent, zinc-plated and thick-film-passivated BM-...-W66
- * Flange Clamp made of Steel S355J0 / C45 or equivalent, zinc/nickel-plated (on request) BM-...-W3
- * Flange Clamp made of Stainless Steel V4A - 1.4404 (on request) BM-...-W5

- * Kit including Metric bolts 8.8, spring rings, O-ring made of NBR (Buna-N®) BM-...-M-B-W66-K
- * Kit including Metric bolts 8.8, spring rings, O-ring made of FKM/FPM (Viton®) BM-...-M-V-W66-K

- * Kit including Metric bolts 10.9, spring rings, O-ring made of NBR (Buna-N®) BM-...-MH-B-W129-K
- * Kit including UNC bolts (Grade 8), spring rings, O-ring made of NBR (Buna-N®) BM-...-U-B-W129-K



SAE Split Flange Halves (Flat Style)
Type DB-FL ▪ 3000 / 6000 PSI Series

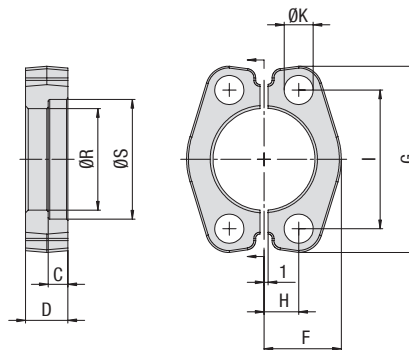

3000 PSI Standard Pressure Series (according to ISO 6162-1:2002)

Nominal Size	DN (in)	PN ¹ (bar/PSI)	Dimensions (mm/in)										Weight per 100	for Bolts		Ordering Codes
			8.8	10.9 (MH)	ØR	ØS	C	D	F	G	H	I		ØK ²	Metric	
13	1/2	350	350	24,3	31	6,2	13	22,8	54	8,75	38,1	8,7	10,6	M8x25	5/16-18 UNC x 1-1/4	DB-FL-301-W66
		5075	5075	.96	1.22	.24	.51	.90	2.13	.34	1.50	.34	23.32			
19	3/4	350	350	32,2	38,9	6,2	14	25,9	65	11,15	47,6	10,5	15,1	M10x30	3/8-16 UNC x 1-1/4	DB-FL-302-W66
		5075	5075	1.27	1.53	.24	.55	1.02	2.56	.44	1.87	.41	33.13			
25	1	250	315	38,5	45,3	7,5	16	29,2	70	13,1	52,4	10,5	19,0	M10x30	3/8-16 UNC x 1-1/4	DB-FL-303-W66
		3625	3625	1.52	1.78	.30	.63	1.15	2.76	.52	2.06	.41	41.80			
32	1-1/4	200	250	43,7	51,6	7,5	14	36,6	79	15,1	58,7	10,5	25,4	M10x30		DB-FL-304-M-W66
		2900	2900	1.72	2.03	.30	.55	1.44	3.11	.59	2.31	.41	55.88			
38	1-1/2	200	200	50,8	61,6	7,5	16	41,1	94	17,85	69,9	13,5	40,3	M12x35	1/2-13 UNC x 1-1/2	DB-FL-305-W66
		2900	2900	2.00	2.43	.30	.63	1.62	3.70	.70	2.75	.53	88.66			
51	2	160	200	62,8	72,3	9	16	48,2	102	21,45	77,8	13,5	45,4	M12x35	1/2-13 UNC x 1-1/2	DB-FL-306-W66
		2320	2320	2.47	2.85	.35	.63	1.90	4.02	.84	3.06	.53	99.81			
64	2-1/2	100	160	74,9	84,9	9	19	53	115	25,4	88,9	13,5	63,4	M12x40	1/2-13 UNC x 1-1/2	DB-FL-307-W66
		1450	1450	2.95	3.34	.35	.75	2.09	4.53	1.00	3.50	.53	139.48			
76	3	100	160	90,9	102,4	9	22	64,3	135	30,95	106,4	17	103,6	M16x50	5/8-11 UNC x 2	DB-FL-308-W66
		1450	1450	3.58	4.03	.35	.87	2.53	5.31	1.22	4.19	.67	227.92			

6000 PSI High Pressure Series (according to ISO 6162-2:2002)

Nominal Size	DN (in)	PN ¹ (bar/PSI)	Dimensions (mm/in)										Weight per 100	for Bolts		Ordering Codes
			8.8	10.9 (MH)	ØR	ØS	C	D	F	G	H	I		ØK ²	Metric	
13	1/2	350	420	24,6	32,5	7,2	16	23,6	56	9,1	40,5	8,7	15,1	M8x30	5/16-18 UNC x 1-1/4	DB-FL-601-W66
		5075	6090	.97	1.28	.28	.63	.93	2.20	.36	1.59	.34	33.18			
19	3/4	350	420	32,5	42	8,2	20	30,0	71	11,9	50,8	10,5	30,8	M10x35	3/8-16 UNC x 1-1/2	DB-FL-602-W66
		5075	6090	1.28	1.65	.32	.79	1.18	2.80	.47	2.00	.41	67.76			
25	1	350	420	38,8	48,4	9	25	34,8	81	13,9	57,2	13	52,2	M12x45		DB-FL-603-M-W66
		5075	6090	1.53	1.91	.35	.98	1.37	3.19	.55	2.25	.51	114.84			
32	1-1/4	350	420	44,5	54,8	9,8	27	38,6	95	15,9	66,6	15	69,5	M14x45		DB-FL-604-M14-W66
		5075	6090	1.75	2.16	.39	1.06	1.52	3.74	.63	2.62	.59	152.90			
38	1-1/2	350	420	51,6	64,3	12	30	47,5	113	18,25	79,3	17	116,8	M16x55	5/8-11 UNC x 2-1/4	DB-FL-605-W66
		5075	6090	2.03	2.53	.47	1.18	1.87	4.45	.72	3.12	.67	256.96			
51	2	350	420	67,6	80,2	12	37	56,9	133	22,25	96,8	21	184,7	M20x70	3/4-10 UNC x 2-3/4	DB-FL-606-W66
		5075	6090	2.66	3.16	.47	1.46	2.24	5.24	.88	3.81	.83	406.34			
64	2-1/2	350	420	89,5	108,5	20	48	75	166	29,35	123,8	25	281,4	M24x75		DB-FL-607-M-W66
		5075	6090	3.52	4.27	.79	1.89	2.95	6.54	1.16	4.87	.98	619.08			
76	3	350	420	114,5	132,5	25	58	89	210	35,7	152,4	32	462,1	M30x90		DB-FL-608-M-W66
		5075	6090	4.51	5.22	.98	2.28	3.50	8.27	1.41	6.00	1.26	1016.62			

Materials / Ordering Options / Examples

- * Pair of SAE Split Flange Halves (Flat Style) made of Steel C55 or equivalent, zinc-plated and thick-film-passivated **DB-FL-...-W66**
- * Kit including Metric bolts 8.8, spring rings, O-ring made of NBR (Buna-N®) **DB-FL-...-M-B-W66-K**
- * Kit including Metric bolts 8.8, spring rings, O-ring made of FKM/FPM (Viton®) **DB-FL-...-M-V-W66-K**
- * Kit including Metric bolts 10.9, spring rings, O-ring made of NBR (Buna-N®) **DB-FL-...-MH-B-W129-K**
- * Kit including UNC bolts (Grade 8), spring rings, O-ring made of NBR (Buna-N®) **DB-FL-...-U-B-W129-K**

¹ The maximum working pressure PN (bar/PSI) applies only to the flange itself and depends on the bolts used (Grade 8.8 / 10.9). The actual maximum working pressure depends on the thickness and the quality of the tube used.

² Dimensions of screw holes in part different to the ISO to match both Metric and UNC bolts.



SAE Flange Clamp (Flat Style)
Type BM-FL • 3000 / 6000 PSI Series

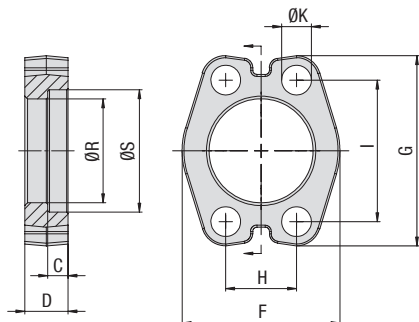

A

3000 PSI Standard Pressure Series (according to ISO 6162-1:2002)

Nominal Size	DN	(in)	PN ¹		Dimensions								Weight	for Bolts		Ordering Codes
			(bar/PSI)	(MH)	ØR	ØS	C	D	F	G	H	I		ØK ²	per 100	
13	1/2	350	350	24,3	31	6,2	13	45,6	54	17,5	38,1	8,7	11,4	M8x25	5/16-18 UNC x 1-1/4	BM-FL-301-W66
		5075	5075	.96	1.22	.24	.51	1.80	2.13	.69	1.50	.34	25.08			
19	3/4	350	350	32,2	38,9	6,2	14	51,8	65	22,3	47,6	10,5	15,0	M10x30	3/8-16 UNC x 1-1/4	BM-FL-302-W66
		5075	5075	1.27	1.53	.24	.55	2.04	2.56	.88	1.87	.41	33.00			
25	1	250	315	38,5	45,3	7,5	16	58,4	70	26,2	52,4	10,5	19,2	M10x30	3/8-16 UNC x 1-1/4	BM-FL-303-W66
		3625	4568	1.52	1.78	.30	.63	2.30	2.76	1.03	2.06	.41	42.24			
32	1-1/4	200	250	43,7	51,6	7,5	14	73,2	79	30,2	58,7	10,5	25,7	M10x30		BM-FL-304-M-W66
		2900	3625	1.72	2.03	.30	.55	2.88	3.11	1.19	2.31	.41	56.54			
38	1-1/2	200	200	50,8	61,1	7,5	16	82,2	94	35,7	69,9	13,5	39,1	M12x35	1/2-13 UNC x 1-1/2	BM-FL-305-W66
		2900	2900	2.00	2.41	.30	.63	3.24	3.70	1.41	2.75	.53	86.02			
51	2	160	200	62,8	72,3	9	16	96,4	102	42,9	77,8	13,5	47,3	M12x35	1/2-13 UNC x 1-1/2	BM-FL-306-W66
		2320	2900	2.47	2.85	.35	.63	3.80	4.02	1.69	3.06	.53	104.06			
64	2-1/2	100	160	74,9	84,9	9	19	106	115	50,8	88,9	13,5	63,6	M12x40	1/2-13 UNC x 1-1/2	BM-FL-307-W66
		1450	2320	2.95	3.34	.35	.75	4.17	4.53	2.00	3.50	.53	139.92			
76	3	100	160	90,9	102,4	9	22	128,6	135	61,9	106,4	17	104,9	M16x50	5/8-11 UNC x 2	BM-FL-308-W66
		1450	2320	3.58	4.03	.35	.87	5.06	5.31	2.44	4.19	.67	230.78			

6000 PSI High Pressure Series (according to ISO 6162-2:2002)

Nominal Size	DN	(in)	PN ¹		Dimensions								Weight	for Bolts		Ordering Codes
			(bar/PSI)	(MH)	ØR	ØS	C	D	F	G	H	I		ØK ²	per 100	
13	1/2	350	420	24,6	32,5	7,2	16	47,2	56	18,2	40,5	8,7	15,0	M8x30	5/16-18 UNC x 1-1/4	BM-FL-601-W66
		5075	6090	.97	1.28	.28	.63	1.86	2.20	.72	1.59	.34	33.00			
19	3/4	350	420	32,5	42	8	20	60	71	23,8	50,8	10,5	30,1	M10x35	3/8-16 UNC x 1-1/2	BM-FL-602-W66
		5075	6090	1.28	1.65	.31	.79	2.36	2.80	.94	2.00	.41	66.22			
25	1	350	420	38,8	48,4	9	25	69,6	81	27,8	57,2	13	49,0	M12x45		BM-FL-603-M-W66
		5075	6090	1.53	1.91	.35	.98	2.74	3.19	1.09	2.25	.51	107.80			
32	1-1/4	350	420	44,5	54,8	9,8	27	77,2	95	31,8	66,6	15	71,5	M14x45		BM-FL-604-M14-W66
		5075	6090	1.75	2.16	.39	1.06	3.04	3.74	1.25	2.62	.59	157.30			
38	1-1/2	350	420	51,6	64,3	12	30	89,4	113	36,5	79,3	17	118,9	M16x55	5/8-11 UNC x 2-1/4	BM-FL-605-W66
		5075	6090	2.03	2.53	.47	1.18	3.52	4.45	1.44	3.12	.67	261.58			
51	2	350	420	67,6	80,2	12	37	113,4	133	44,5	96,8	21	187,4	M20x70	3/4-10 UNC x 2-3/4	BM-FL-606-W66
		5075	6090	2.66	3.16	.47	1.46	4.46	5.24	1.75	3.81	.83	412.28			
64	2-1/2	350	420	89,5	108,5	20	48	150	166	58,7	123,8	25	187,4	M24x75		BM-FL-607-M-W66
		5075	6090	3.52	4.27	.79	1.89	5.91	6.54	2.31	4.87	.98	412.28			
76	3	350	420	114,5	132,5	25	58	178	210	71,4	152,4	32	392,0	M30x90		BM-FL-608-M-W66
		5075	6090	4.51	5.22	.98	2.28	7.01	8.27	2.81	6.00	1.26	862.40			

¹ The maximum working pressure PN (bar/PSI) applies only to the flange itself and depends on the bolts used (Grade 8.8 / 10.9). The actual maximum working pressure depends on the thickness and the quality of the tube used.

² Dimensions of screw holes in part different to the ISO to match both Metric and UNC bolts.

Materials / Ordering Options / Examples

- * Flange Clamp (Flat Style) made of Steel C55 or equivalent, zinc-plated and thick-film-passivated BM-FL-...-W66
- * Kit including Metric bolts 8.8, spring rings, O-ring made of NBR (Buna-N®) BM-FL-...-M-B-W66-K
- * Kit including Metric bolts 8.8, spring rings, O-ring made of FKM/FPM (Viton®) BM-FL-...-M-V-W66-K
- * Kit including Metric bolts 10.9, spring rings, O-ring made of NBR (Buna-N®) BM-FL-...-MH-B-W129-K
- * Kit including UNC bolts (Grade 8), spring rings, O-ring made of NBR (Buna-N®) BM-FL-...-U-B-W129-K



SAE Flange Clamp with Metric Tapped Holes
Type BM-G • 3000 / 6000 PSI Series

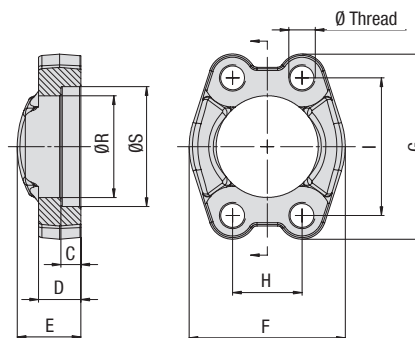

3000 PSI Standard Pressure Series (according to ISO 6162-1:2002)

Nominal Size	DN	(in)	PN ¹ (bar/PSI)		Dimensions (mm/in)								Weight (kg/lbs) ca. per 100	Ø Thread ²	Ordering Codes	
			8.8	10.9 (MH)	ØR	ØS	C	D	E	F	G	H				I
13	1/2		350	350	24,3	31	6,2	13	19	46	54	17,5	38,1	13,9	M8	BM-G-301-W66
			5075	5075	.96	1.22	.24	.51	.75	1.81	2.13	.69	1.50	30.58		
19	3/4		350	350	32,2	38,9	6,2	14	22	52	65	22,3	47,6	19,0	M10	BM-G-302-W66
			5075	5075	1.27	1.53	.24	.55	.87	2.05	2.56	.88	1.87	41.80		
25	1		250	315	38,5	45,3	7,5	16	24	59	70	26,2	52,4	24,4	M10	BM-G-303-W66
			3625	4568	1.52	1.78	.30	.63	.94	2.32	2.76	1.03	2.06	53.68		
32	1-1/4		200	250	43,7	51,6	7,5	14	22	73	79,5	30,2	58,7	32,1	M10 (M12)	BM-G-304-W66
			2900	3625	1.72	2.03	.30	.55	.87	2.87	3.13	1.19	2.31	70.62		
38	1-1/2		200	200	50,8	61,1	7,5	16	25	83	94	35,7	69,9	49,0	M12 (M14)	BM-G-305-W66
			2900	2900	2.00	2.41	.30	.63	.98	3.27	3.70	1.41	2.75	107.80		
51	2		160	200	62,8	72,3	9	16	26	97	102	42,9	77,8	55,5	M12 (M14)	BM-G-306-W66
			2320	2900	2.47	2.85	.35	.63	1.02	3.82	4.02	1.69	3.06	122.10		
64	2-1/2		100	160	74,9	84,9	9	19	38	109	114,5	50,8	88,9	94,9	M12 (M14)	BM-G-307-W66
			1450	2320	2.95	3.34	.35	.75	1.50	4.29	4.51	2.00	3.50	208.78		
76	3		100	160	90,9	102,4	9	22	41	131	135	61,9	106,4	138,1	M16	BM-G-308-W66
			1450	2320	3.58	4.03	.35	.87	1.61	5.16	5.31	2.44	4.19	303.82		
89	3-1/2		35	35	102,4	115,1	10,7	22	28	140	152	69,9	120,7	132,5	M16	BM-G-309-W66
			508	508	4.03	4.53	.42	.87	1.10	5.51	5.98	2.75	4.75	291.50		
102	4		35	35	115	127,8	10,7	25	35	152	162	77,8	130,2	174,8	M16	BM-G-310-W66
			508	508	4.53	5.03	.42	.98	1.38	5.98	6.38	3.06	5.13	384.56		
127	5		35	35	140,5	153,2	10,7	28	41	181	184	92,1	152,4	256,0	M16	BM-G-311-W66
			508	508	5.53	6.03	.42	1.10	1.61	7.13	7.24	3.63	6.00	563.20		

6000 PSI High Pressure Series (according to ISO 6162-2:2002)

Nominal Size	DN	(in)	PN ¹ (bar/PSI)		Dimensions (mm/in)								Weight (kg/lbs) ca. per 100	Ø Thread	Ordering Codes	
			8.8	10.9 (MH)	ØR	ØS	C	D	E	F	G	H				I
13	1/2		350	420	24,6	32,5	7,2	16	22	48	56,5	18,2	40,5	18,3	M8	BM-G-601-W66
			5075	6090	.97	1.28	.28	.63	.87	1.89	2.22	.72	1.59	40.26		
19	3/4		350	420	32,5	42	8,2	19	28	60	71	23,8	50,8	34,0	M10	BM-G-602-W66
			5075	6090	1.28	1.65	.32	.75	1.10	2.36	2.80	.94	2.00	74.80		
25	1		350	420	38,8	48,4	9	24	33	70	81	27,8	57,2	57,4	M12	BM-G-603-W66
			5075	6090	1.53	1.91	.35	.94	1.30	2.76	3.19	1.09	2.25	126.28		
32	1-1/4		350	420	44,5	54,8	9,8	27	38	78	95	31,8	66,6	82,9	M12	BM-G-604-W66
			5075	6090	1.75	2.16	.39	1.06	1.50	3.07	3.74	1.25	2.62	182.38		
32	1-1/4		350	420	44,5	54,8	9,8	27	38	78	95	31,8	66,6	85,4	M14	BM-G-604-M14-W66
			5075	6090	1.75	2.16	.39	1.06	1.50	3.07	3.74	1.25	2.62	187.88		
38	1-1/2		350	420	51,6	64,3	12	30	43	95	113	36,5	79,3	143,4	M16	BM-G-605-W66
			5075	6090	2.03	2.53	.47	1.18	1.69	3.74	4.45	1.44	3.12	315.48		
51	2		350	420	67,6	80,2	12	37	52	114	133	44,5	96,8	218,8	M20	BM-G-606-W66
			5075	6090	2.66	3.16	.47	1.46	2.05	4.49	5.24	1.75	3.81	481.36		
64	2-1/2		350	420	108,5	89,5	48	48	20	150	58,7	175	123,8	403,8	M24	BM-G-607-W66
			5075	6090	7.5	6.2	3.3	3.3	1.4	10.3	4.0	12.1	8.5	888.36		
76	3		350	420	132,5	114,5	58	58	25	178	71,4	210	152,4	704,2	M30	BM-G-608-W66
			5075	6090	9.1	7.9	4.0	4.0	1.7	12.3	4.9	14.5	10.5	1549.24		

Materials / Ordering Options / Examples

- * Flange Clamp with Metric tapped holes made of Steel S355J0 / C45 or equivalent, zinc-plated and thick-film-passivated **BM-G-...-W66**
- * Flange Clamp with Metric tapped holes made of Steel S355J0 / C45 or equivalent, zinc/nickel-plated (on request) **BM-G-...-W3**
- * Flange Clamp with Metric tapped holes made of Stainless Steel V4A – 1.4404 (on request) **BM-G-...-W5**
- * Size of Metric tapped holes deviating from the standard (e.g. M14) **BM-G-...-M14-W66**

¹ The maximum working pressure PN (bar/PSI) applies only to the flange itself and depends on the bolts used (Grade 8.8 / 10.9). The actual maximum working pressure depends on the thickness and the quality of the tube used.

² Alternative options shown in brackets are available on request.



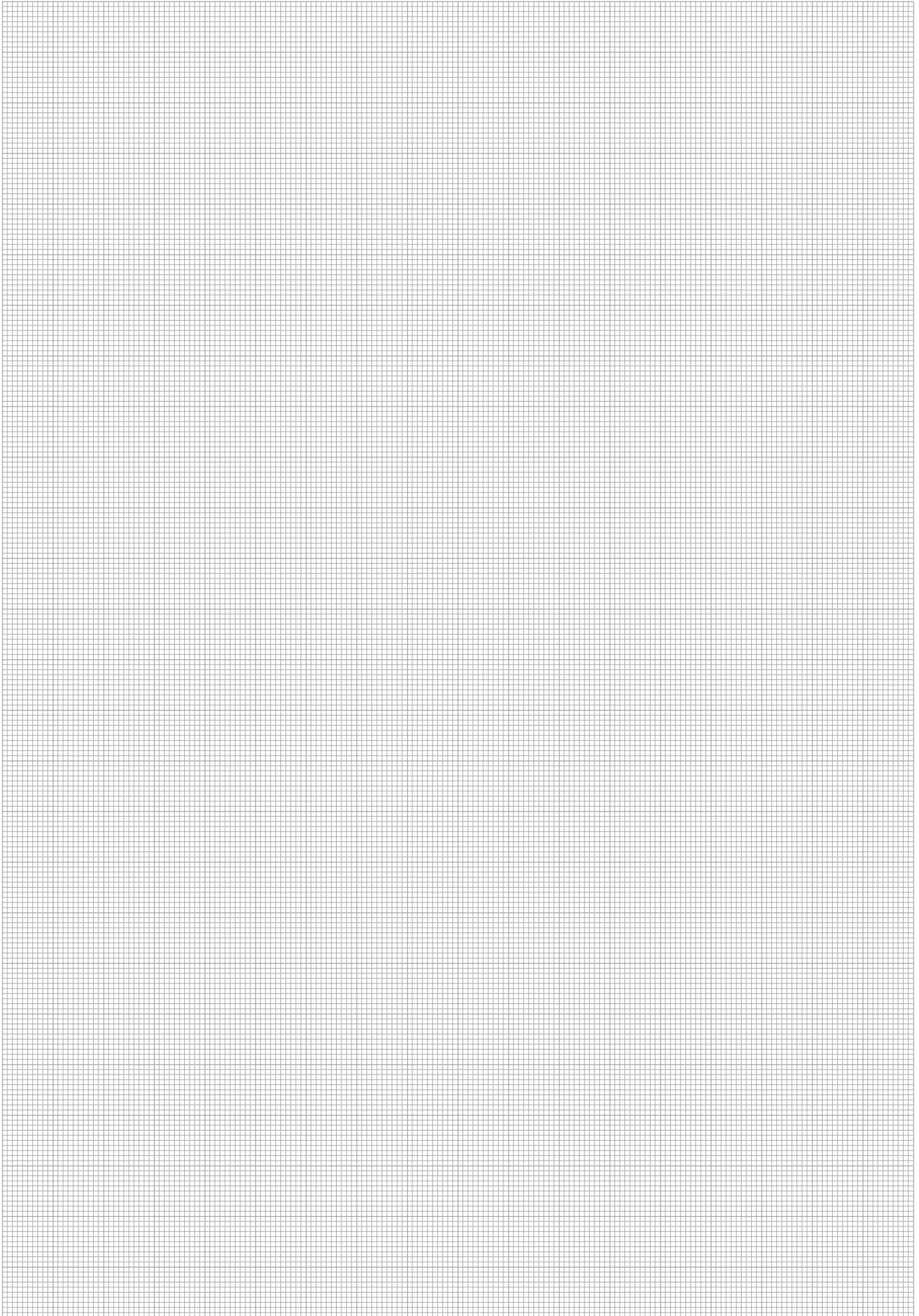

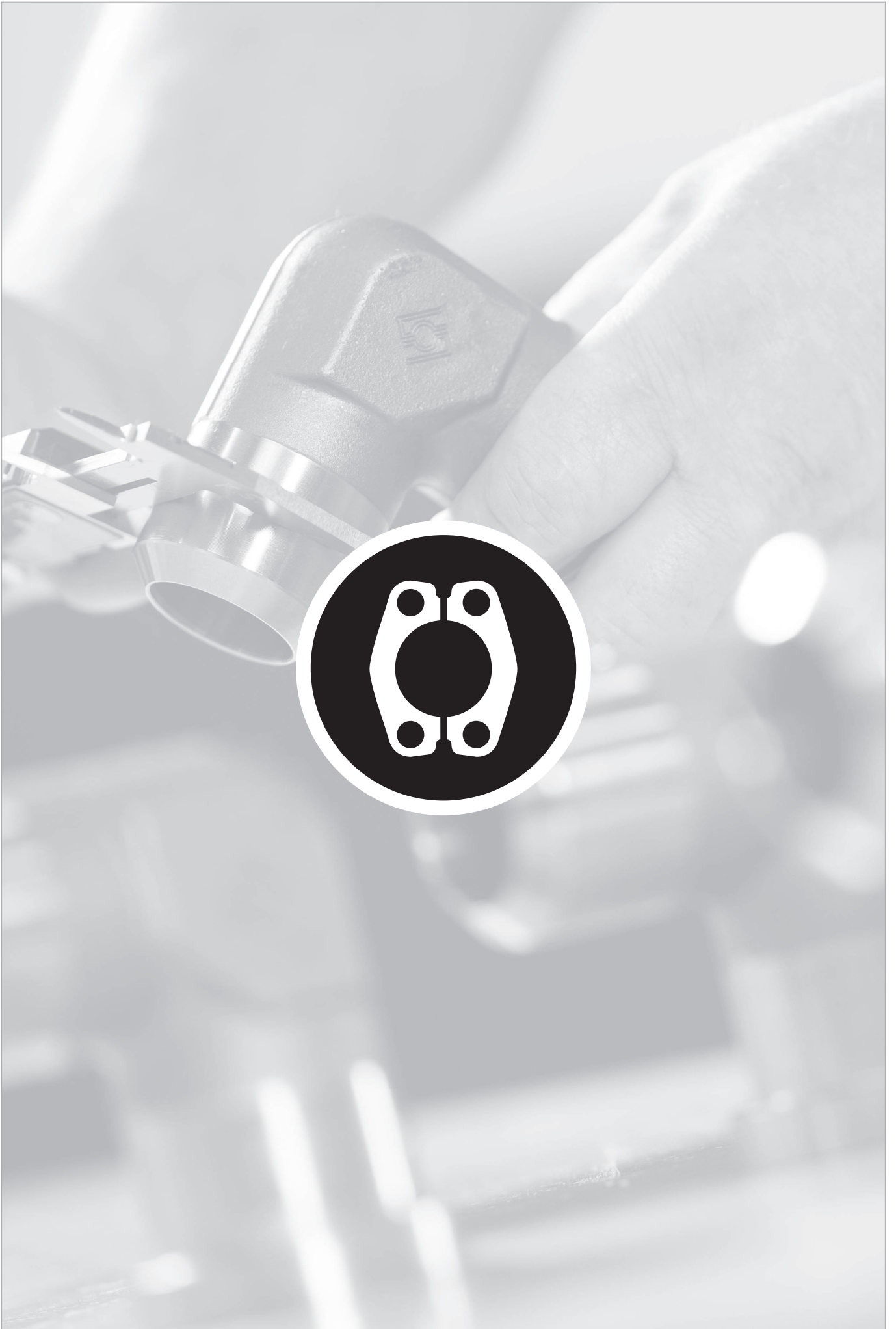

	SAE Butt-Weld Flange Adaptor CAG-ST	24
	SAE Butt-Weld Counterflange Adaptor CSG-ST	24
	SAE Socket-Weld Flange Adaptor CAG-ES	26
	SAE Socket-Weld Counterflange Adaptor CSG-ES	26
	SAE Flange Adaptor with Male BSPT Thread CAG-T	28
	SAE Counterflange Adaptor with Male BSPT Thread CSG-T	28
	SAE Flange Adaptor with Male NPT Thread CAG-N	30
	SAE Counterflange Adaptor with Male NPT Thread CSG-N	30
	SAE Flange Adaptor with Male Metric Thread and 24° Conical Bore (Shape W acc. to DIN 3861) CAG-L/S	32
	SAE 90° Butt-Weld Flange Adaptor CAG90-ST	34
	SAE 90° Flange Adaptor with Male Metric Thread and 24° Conical Bore (Shape W acc. to DIN 3861) CAG90-L/S	36



SAE Butt-Weld Flange / Counterflange Adaptor Type CAG/CSG-ST • 3000 PSI Series

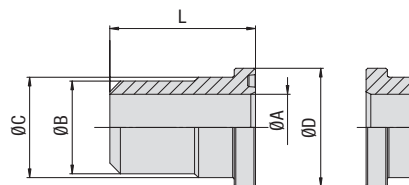

CAG

CSG

3000 PSI Standard Pressure Series (according to ISO 6162-1:2002)

Nominal Size		PN ¹ (bar/PSI)		Dimensions (mm/in)			Ordering Codes
DN	(in)	8.8	10.9 (MH)	ØC	ØD	L	
13	1/2	350	350	24	30,2	41	CAG-301-ST- ** /**-W1
		5075	5075	.94	1.19	1.61	
/ replace with ØB / ØA: 16/12 • 20/15 • 21,3/15,7 • 21,3/13,7 • 21,3/12							
19	3/4	350	350	31,5	38,1	50	CAG-302-ST- ** /**-W1
		5075	5075	1,24	1.50	1.97	
/ replace with ØB / ØA: 25/19 • 26,9/19,7 • 28/19							
25	1	250	315	38	44,45	50	CAG-303-ST- ** /**-W1
		3625	4568	1.50	1.75	1.97	
/ replace with ØB / ØA: 25/19 • 28/22 • 30/24 • 30/22 • 33,7/24,7 • 38/30 • 38/28							
32	1-1/4	200	250	43	50,8	55	CAG-304-ST- ** /**-W1
		2900	3625	1.69	2.00	2.17	
/ replace with ØB / ØA: 25/19 • 30/24 • 38/32 • 38/30 • 38/28 • 42,4/33,4 • 42,4/29,8 • 43/31							
38	1-1/2	200	200	50	60,35	57	CAG-305-ST- ** /**-W1
		2900	2900	1.97	2.38	2.24	
/ replace with ØB / ØA: 38/30 • 42/36 • 42/35 • 42/32 • 45/43 • 48,3/41 • 48,3/38,3 • 48,3/34 • 48,3/35 • 50/38							
51	2	160	200	62	71,4	57	CAG-306-ST- ** /**-W1
		2320	2900	2.44	2.81	2.24	
/ replace with ØB / ØA: 48,3/38,4 • 55/45 • 60,3/54,5 • 60,3/52 • 60,3/50,3 • 60,3/47,7 • 60,3/44,3							
64	2-1/2	100	160	74	84,1	58	CAG-307-ST- ** /**-W1
		1450	2320	2.91	3.31	2.28	
/ replace with ØB / ØA: 65/53 • 70/55 • 74/65 • 74/61,8 • 74/58							
76	3	100	160	90	101,6	60	CAG-308-ST- ** /**-W1
		1450	2320	3.54	4.00	2.36	
/ replace with ØB / ØA: 80/68 • 89/82,5 • 89/81 • 89/76 • 89/74 • 89/70							
89	3-1/2	35	35	102	114,3	80	CAG-309-ST- ** /**-W1
		508	508	4.02	4.50	3.15	
/ replace with ØB / ØA: 100/88 • 89/81,7 • 89/73							
102	4	35	35	114	127	80	CAG-310-ST- ** /**-W1
		508	508	4.49	5.00	3.15	
/ replace with ØB / ØA: 110/98 • 114/107 • 114/102 • 114/96,7							
127	5	35	35	140	152,4	80	CAG-311-ST- ** /**-W1
		508	508	5.51	6.00	3.15	
/ replace with ØB / ØA: 133/120 • 139,7/131,7 • 139,7/119,7							

Materials / Ordering Options / Examples

- * SAE Flange Adaptor (without O-ring) made of Steel S355J0 or equivalent, blank (oiled)
- * SAE Counterflange Adaptor made of Steel S355J0 or equivalent, blank (oiled)
- * SAE Flange Adaptor (without O-ring) made of Stainless Steel V4A – 1.4571 (on request)

CAG-...-ST-**-W1

CSG-...-ST-**-W1

CAG-...-ST-**-W5

- * Kit with DB including Metric bolts 8.8, spring rings, O-ring made of NBR (Buna-N®)
- * Kit with DB including Metric bolts 8.8, spring rings, O-ring made of FKM/FPM (Viton®)
- * Kit with DB including Metric bolts 10.9, spring rings, O-ring made of NBR (Buna-N®)
- * Kit with DB including UNC bolts (Grade 8), spring rings, O-ring made of NBR (Buna-N®)
- * Kit with BM including Metric bolts 8.8, spring rings, O-ring made of NBR (Buna-N®)

CAG-...-ST-**-W57-K

CAG-...-ST-**-V-W57-K

CAG-...-ST-**-MH-W129-K

CAG-...-ST-**-U-W129-K

CAG-...-ST-**-BM-W57-K

Please always indicate ØB / ØA.

¹ The maximum working pressure PN (bar/PSI) applies only to the flange itself and depends on the bolts used (Grade 8.8 / 10.9). The actual maximum working pressure depends on the thickness and the quality of the tube used.

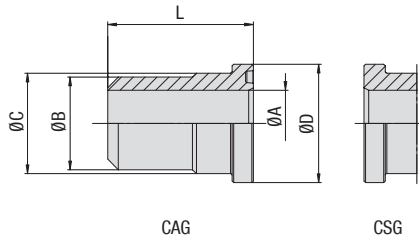

SAE Butt-Weld Flange / Counterflange Adaptor
 Type CAG/CSG-ST • 6000 PSI Series

B

6000 PSI High Pressure Series (according to ISO 6162-2:2002)

Nominal Size		PN ¹ (bar/PSI)		Dimensions (mm/in)			Ordering Codes
DN	(in)	8.8	10.9 (MH)	ØC	ØD	L	
13	1/2	350	420	24	31,8	34	CAG-601-ST-**-**-W1
		5075	6090	.94	1.25	1.34	
/ replace with ØB / ØA: 16/12 • 20/15 • 21,3/12,3							
19	3/4	350	420	32	41,3	38	CAG-602-ST-**-**-W1
		5075	6090	1.26	1.63	1.50	
/ replace with ØB / ØA: 16/12 • 20/14 • 25/19 • 25/18 • 25/17 • 26,9/15,7 • 28/18							
25	1	350	420	38	47,6	40	CAG-603-ST-**-**-W1
		5075	6090	1.50	1.87	1.57	
/ replace with ØB / ØA: 25/19 • 30/24 • 30/22 • 33,7/21 • 33,7/19,5 • 38/30 • 38/28							
32	1-1/4	350	420	44	54	45	CAG-604-ST-**-**-W1 ²
		5075	6090	1.73	2.13	1.77	
/ replace with ØB / ØA: 25/19 • 30/24 • 38/30 • 38/28 • 38/27 • 42,4/29,8							
38	1-1/2	350	420	51	63,5	50	CAG-605-ST-**-**-W1
		5075	6090	2.01	2.50	1.97	
/ replace with ØB / ØA: 38/28 • 45/32 • 48,3/38,3 • 48,3/35,7 • 48,3/34 • 48,3/32,3 • 48,3/30,7 • 50/38 • 51/35							
51	2	350	420	67	79,4	58	CAG-606-ST-**-**-W1
		5075	6090	2.64	3.13	2.28	
/ replace with ØB / ØA: 48,3/35,7 • 60,3/47,7 • 60,3/44,3 • 60,3/42,8 • 60,3/40,3 • 60,3/33,5 • 65 /39							
64	2-1/2	350	420	89	108	75	CAG-607-ST-**-**-W1
		5075	6090	3.50	4.25	2.95	
/ replace with ØB / ØA: 76,1/60 • 76,1/56 • 89/69 • 89/67 • 89/60,5							
76	3	350	420	114	131,6	80	CAG-608-ST-**-**-W1
		5075	6090	4.49	5.18	3.15	
/ replace with ØB / ØA: 89/69 • 89/66,7 • 89/60,5 • 114/92,3 • 114/79,3							

¹ The maximum working pressure PN (bar/PSI) applies only to the flange itself and depends on the bolts used (Grade 8.8 / 10.9). The actual maximum working pressure depends on the thickness and the quality of the tube used.

² According to ISO 6162-2 bolts M12 should be used but because usually bolts M14 are used the description of the complete part must show M14 (e.g. CAG-604-ST-**-**-M14#K).

Materials / Ordering Options / Examples

- * SAE Flange Adaptor (without O-ring) made of Steel S355J0 or equivalent, blank (oiled) CAG-...-ST-**-**-W1
- * SAE Counterflange Adaptor made of Steel S355J0 or equivalent, blank (oiled) CSG-...-ST-**-**-W1
- * SAE Flange Adaptor (without O-ring) made of Stainless Steel V4A – 1.4571 (on request) CAG-...-ST-**-**-W5
- * Kit with DB including Metric bolts 8.8, spring rings, O-ring made of NBR (Buna-N®) CAG-...-ST-**-**-W57-K
- * Kit with DB including Metric bolts 8.8, spring rings, O-ring made of FKM/FPM (Viton®) CAG-...-ST-**-**-V-W57-K
- * Kit with DB including Metric bolts 10.9, spring rings, O-ring made of NBR (Buna-N®) CAG-...-ST-**-**-MH-W129-K
- * Kit with DB including UNC bolts (Grade 8), spring rings, O-ring made of NBR (Buna-N®) CAG-...-ST-**-**-U-W129-K
- * Kit with BM including Metric bolts 8.8, spring rings, O-ring made of NBR (Buna-N®) CAG-...-ST-**-**-BM-W57-K

Please always indicate ØB / ØA.



**SAE Socket-Weld Flange / Counterflange Adaptor
Type CAG/CSG-ES - 3000 PSI Series**

B

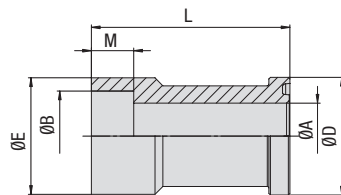

Version A (CAG) - not for use with SAE Flange Clamps BM

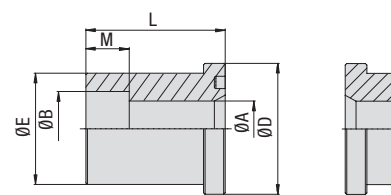

Version B (CAG / CSG)

3000 PSI Standard Pressure Series (according to ISO 6162-1:2002)

Nominal Size DN	(in)	PN ¹ (bar/PSI)		Dimensions (mm/in)						Version	Weight (kg/lbs) ca. per 100	Ordering Codes
		8.8	10.9 (MH)	ØA	ØB	ØD	ØE	M	L			
13	1/2	350	350	12	16,5	30,2	24	12	35	B	11,0	CAG-301-ES-16.5/12-W1
		5075	5075	.47	.65	1.19	.94	.47	1.38		24.20	
13	1/2	350	350	12	17,6	30,2	24	12	35	B	99,0	CAG-301-ES-17.6/12-W1
		5075	5075	.47	.69	1.19	.94	.47	1.38		217.80	
13	1/2	350	350	15	20,5	30,2	30	13	60	A	15,7	CAG-301-ES-20.5/15-W1
		5075	5075	.59	.81	1.19	1.18	.51	2.36		34.54	
13	1/2	350	350	15	21,7	30,2	30	13	60	A	15,8	CAG-301-ES-21.7/15-W1
		5075	5075	.59	.85	1.19	1.18	.51	2.36		34.76	
19	3/4	350	350	13	20,5	38,1	31,5	12	40	B	18,4	CAG-302-ES-20.5/13-W1
		5075	5075	.51	.81	1.50	1.24	.47	1.57		40.49	
19	3/4	350	350	13	21,7	38,1	31,5	13	40	B	18,4	CAG-302-ES-21.7/13-W1
		5075	5075	.51	.85	1.50	1.24	.51	1.57		40.49	
19	3/4	350	350	19	25,5	38,1	35	13	68	A	28,2	CAG-302-ES-25.5/19-W1
		5075	5075	.75	1.00	1.50	1.38	.51	2.68		62.04	
19	3/4	350	350	19	27,3	38,1	35	13	68	A	27,1	CAG-302-ES-27.3/19-W1
		5075	5075	.75	1.07	1.50	1.38	.51	2.68		59.62	
25	1	250	315	19	27,3	44,45	38	14	45	B	40,0	CAG-303-ES-27.3/19-W1
		3625	4568	.75	1.07	1.75	1.50	.55	1.77		88.00	
25	1	250	315	23	30,5	44,45	44	16	75	A	46,1	CAG-303-ES-30.5/23-W1
		3625	4568	.91	1.20	1.75	1.73	.63	2.95		101.42	
25	1	250	315	25	34	44,45	44	16	75	A	46,0	CAG-303-ES-34/25-W1
		3625	4568	.98	1.34	1.75	1.73	.63	2.95		101.20	
32	1-1/4	200	250	25	30,5	50,8	43	16	50	B	36,0	CAG-304-ES-30.5/25-W1
		2900	3625	.98	1.20	2.00	1.69	.63	1.97		79.20	
32	1-1/4	200	250	25	34	50,8	43	16	50	B	32,0	CAG-304-ES-34/25-W1
		2900	3625	.98	1.34	2.00	1.69	.63	1.97		70.40	
32	1-1/4	200	250	32	38,5	50,8	55	18	95	A	64,0	CAG-304-ES-38.5/32-W1
		2900	3625	1.26	1.52	2.00	2.17	.71	3.74		140.80	
32	1-1/4	200	250	32	43	50,8	55	18	95	A	60,0	CAG-304-ES-43/32-W1
		2900	3625	1.26	1.69	2.00	2.17	.71	3.74		132.00	
38	1-1/2	200	200	32	38,5	60,3	50	18	55	B	44,0	CAG-305-ES-38.5/32-W1
		2900	2900	1.26	1.52	2.37	1.97	.71	2.17		96.80	
38	1-1/2	200	200	32	43	60,3	50	18	55	B	46,0	CAG-305-ES-43/32-W1
		2900	2900	1.26	1.69	2.37	1.97	.71	2.17		101.20	
38	1-1/2	200	200	38	49	60,3	63	20	100	A	82,5	CAG-305-ES-49/38-W1
		2900	2900	1.50	1.93	2.37	2.48	.79	3.94		181.50	
38	1-1/2	200	200	38	50,4	60,3	63	20	100	A	80,9	CAG-305-ES-50.4/38-W1
		2900	2900	1.50	1.98	2.37	2.48	.79	3.94		177.98	
51	2	160	200	38	49	71,4	61,8	20	65	B	174,0	CAG-306-ES-49/38-W1
		2320	2900	1.50	1.93	2.81	2.43	.79	2.56		382.80	
51	2	160	200	38	50,7	71,4	61,8	20	65	B	174,0	CAG-306-ES-50.7/38-W1
		2320	2900	1.50	2.00	2.81	2.43	.79	2.56		382.80	
51	2	160	200	50	61	71,4	79	22	107	A	119,7	CAG-306-ES-61/50-W1
		2320	2900	1.97	2.40	2.81	3.11	.87	4.21		263.34	

Materials / Ordering Options / Examples

- * SAE Flange Adaptor (without O-ring) made of Steel S355J0 or equivalent, blank (oiled)
- * SAE Counterflange Adaptor made of Steel S355J0 or equivalent, blank (oiled)
- * SAE Flange Adaptor (without O-ring) made of Stainless Steel V4A – 1.4571 (on request)

CAG-...-ES-**-**/W1
CSG-...-ES-**-**/W1
CAG-...-ES-**-**/W5

- * Kit with DB including Metric bolts 8.8, spring rings, O-ring made of NBR (Buna-N®)
- * Kit with DB including Metric bolts 8.8, spring rings, O-ring made of FKM/FPM (Viton®)
- * Kit with DB including Metric bolts 10.9, spring rings, O-ring made of NBR (Buna-N®)
- * Kit with DB including UNC bolts (Grade 8), spring rings, O-ring made of NBR (Buna-N®)

CAG-...-ES-**-**/W57-K
CAG-...-ES-**-**/V-W57-K
CAG-...-ES-**-**/MH-W129-K
CAG-...-ES-**-**/U-W129-K

Please always indicate ØB / ØA.

¹ The maximum working pressure PN (bar/PSI) applies only to the flange itself and depends on the bolts used (Grade 8.8 / 10.9). The actual maximum working pressure depends on the thickness and the quality of the tube used.

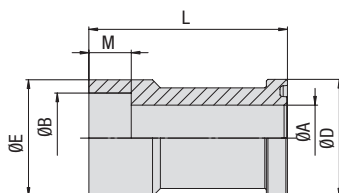
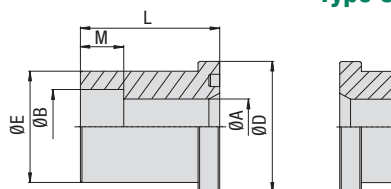

**SAE Socket-Weld Flange / Counterflange Adaptor
Type CAG/CSG-ES - 3000 / 6000 PSI Series**

Version A (CAG) - not for use with SAE Flange Clamps BM

Version B (CAG / CSG)

B
3000 PSI Standard Pressure Series (according to ISO 6162-1:2002)

Nominal Size		PN ¹ (bar/PSI)		Dimensions (mm/in)						Version	Weight (kg/lbs) ca. per 100	Ordering Codes
DN	(in)	8.8	10.9 (MH)	ØA	ØB	ØD	ØE	M	L			
64	2-1/2	100	160	47	61	84,1	73,8	22	75	B	79,0	CAG-307-ES-61/47-W1
		1450	2320	1.85	2.40	3.31	2.91	.87	2.95		173.80	
64	2-1/2	100	160	58	77	84,1	98	24	130	A	215,9	CAG-307-ES-77/58-W1
		1450	2320	2.28	3.03	3.31	3.86	.94	5.12		474.98	
76	3	100	160	58	77	101,6	90	24	85	B	108,0	CAG-308-ES-77/58-W1
		1450	2320	2.28	3.03	4.00	3.54	.94	3.35		237.60	
76	3	100	160	70	90,5	101,6	116	28	150	A	372,0	CAG-308-ES-90.5/70-W1
		1450	2320	2.76	3.56	4.00	4.57	1.10	5.91		818.40	

6000 PSI High Pressure Series (according to ISO 6162-2:2002)

Nominal Size		PN ¹ (bar/PSI)		Dimensions (mm/in)						Version	Weight (kg/lbs) ca. per 100	Ordering Codes
DN	(in)	8.8	10.9 (MH)	ØA	ØB	ØD	ØE	M	L			
13	1/2	350	420	11	16,5	31,8	24	13	35	B	12,5	CAG-601-ES-16.5/11-W1
		5075	6090	.43	.65	1.25	.94	.51	1.38		27.48	
13	1/2	350	420	11	17,6	31,8	24	13	35	B	12,5	CAG-601-ES-17.6/11-W1
		5075	6090	.43	.69	1.25	.94	.51	1.38		27.48	
13	1/2	350	420	15	20,5	31,8	32	13	60	A	19,7	CAG-601-ES-20.5/15-W1
		5075	6090	.59	.81	1.25	1.26	.51	2.36		43.34	
13	1/2	350	420	15	21,7	31,8	32	13	60	A	18,8	CAG-601-ES-21.7/15-W1
		5075	6090	.59	.85	1.25	1.26	.51	2.36		41.36	
19	3/4	350	420	13	20,5	41,3	31,8	13	40	B	19,0	CAG-602-ES-20.5/13-W1
		5075	6090	.51	.81	16.26	1.25	.51	1.57		41.80	
19	3/4	350	420	13	21,7	41,3	31,8	13	40	B	20,1	CAG-602-ES-20.5/15-W1
		5075	6090	.51	.85	16.26	1.25	.51	1.57		44.22	
19	3/4	350	420	19	25,7	41,3	40	13	68	A	36,1	CAG-602-ES-25.5/19-W1
		5075	6090	.75	1.01	1.63	1.57	.51	2.68		79.42	
19	3/4	350	420	19	27,3	41,3	40	13	68	A	35,4	CAG-602-ES-27.3/19-W1
		5075	6090	.75	1.07	1.63	1.57	.51	2.68		77.88	
25	1	350	420	17,5	27,3	47,6	38	13	45	B	35,9	CAG-603-ES-27.3/17.5-W1
		5075	6090	.69	1.07	1.87	1.50	.51	1.77		79.04	
25	1	350	420	25	34	47,6	48	16	75	A	48,0	CAG-603-ES-34/25-W1
		5075	6090	.98	1.34	1.87	1.89	.63	2.95		105.60	
32	1-1/4	350	420	22	34	54	44	16	50	B	52,4	CAG-604-ES-34/22-W1 ²
		5075	6090	.87	1.34	2.13	1.73	.63	1.97		115.28	

¹ The maximum working pressure PN (bar/PSI) applies only to the flange itself and depends on the bolts used (Grade 8.8 / 10.9). The actual maximum working pressure depends on the thickness and the quality of the tube used.

² According to ISO 6162-2 bolts M12 should be used. Since typically bolts M14 are used, the description of the complete part must show M14 (e.g. CAG-604-ES-34/22-M14-W57-K).

Materials / Ordering Options / Examples

- * SAE Flange Adaptor (without O-ring) made of Steel S355J0 or equivalent, blank (oiled) **CAG-...-ES-*/**-W1**
- * SAE Counterflange Adaptor made of Steel S355J0 or equivalent, blank (oiled) **CSG-...-ES-*/**-W1**
- * SAE Flange Adaptor (without O-ring) made of Stainless Steel V4A – 1.4571 (on request) **CAG-...-ES-*/**-W5**
- * Kit with DB including Metric bolts 8.8, spring rings, O-ring made of NBR (Buna-N®) **CAG-...-ES-*/**-W57-K**
- * Kit with DB including Metric bolts 8.8, spring rings, O-ring made of FKM/FPM (Viton®) **CAG-...-ES-*/**-V-W57-K**
- * Kit with DB including Metric bolts 10.9, spring rings, O-ring made of NBR (Buna-N®) **CAG-...-ES-*/**-MH-W129-K**
- * Kit with DB including UNC bolts (Grade 8), spring rings, O-ring made of NBR (Buna-N®) **CAG-...-ES-*/**-U-W129-K**

Please always indicate ØB / ØA.



**SAE Flange / Counterflange Adaptor with Male BSPT Thread
Type CAG/CSG-T • 3000 PSI Series**

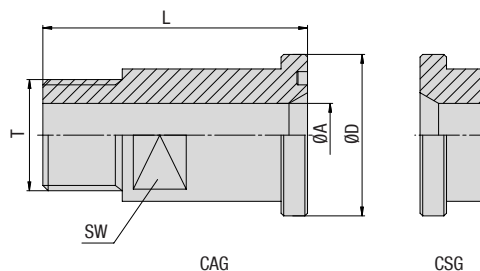

B

3000 PSI Standard Pressure Series (according to ISO 6162-1:2002)

Nominal Size		PN ¹ (bar/PSI)		Dimensions (mm/in)				Weight (kg/lbs) ca. per 100	Ordering Codes	
DN	(in)	8.8	10.9 (MH)	ØA	ØD	L	SW	T (BSPT)		
13	1/2	300	300	12	30,2	50	19	1/2	13,0	CAG-301-T-W66
		4350	4350	.47	1.19	1.97	.75		28,60	
13	1/2	300	300	10	30,2	50	19	3/8 (06)	13,0	CAG-301-T06-W66
		4350	4350	.39	1.19	1.97	.75		28,60	
19	3/4	300	300	17	38,1	55	27	3/4	18,2	CAG-302-T-W66
		4350	4350	.67	1.50	2.17	1.06		40,04	
19	3/4	300	300	12	38,1	55	27	1/2 (08)	18,2	CAG-302-T08-W66
		4350	4350	.47	1.50	2.17	1.06		40,04	
25	1	300	300	22	44,45	60	32	1	40,0	CAG-303-T-W66
		4350	4350	.87	1.75	2.36	1.26		88,00	
25	1	300	300	17	44,45	60	32	3/4 (12)	40,0	CAG-303-T12-W66
		4350	4350	.67	1.75	2.36	1.26		88,00	
32	1-1/4	150	150	27	50,8	65	41	1-1/4	43,7	CAG-304-T-W66
		2175	2175	1.06	2.00	2.56	1.61		96,14	
32	1-1/4	150	150	22	50,8	65	41	1 (16)	44,0	CAG-304-T16-W66
		2175	2175	.87	2.00	2.56	1.61		96,80	
38	1-1/2	150	150	32	60,3	70	46	1-1/2	61,5	CAG-305-T-W66
		2175	2175	1.26	2.37	2.76	1.81		135,30	
38	1-1/2	150	150	27	60,3	70	46	1-1/4 (20)	61,5	CAG-305-T20-W66
		2175	2175	1.06	2.37	2.76	1.81		135,30	
51	2	150	150	40	71,4	75	55	2	100,7	CAG-306-T-W66
		2175	2175	1.57	2.81	2.95	2.17		221,54	
51	2	150	150	30	71,4	75	55	1-1/2 (24)	45,0	CAG-306-T24-W66
		2175	2175	1.18	2.81	2.95	2.17		99,00	

Materials / Ordering Options / Examples

- * SAE Flange Adaptor (without O-ring) made of Steel S355J0 or equivalent, zinc-plated and thick-film-passivated **CAG-...-T-W66**
- * SAE Counterflange Adaptor made of Steel S355J0 or equivalent, zinc-plated and thick-film-passivated **CSG-...-T-W66**
- * SAE Flange Adaptor (without O-ring) made of Stainless Steel V4A – 1.4571 (on request) **CAG-...-T-W5**

- * Size of connection thread deviating from the standard (e.g. 1/2 BSPT) **CAG-...-T08-W66**

- * Kit with DB including Metric bolts 8.8, spring rings, O-ring made of NBR (Buna-N®) **CAG-...-T-W66-K**
- * Kit with DB including Metric bolts 8.8, spring rings, O-ring made of FKM/FPM (Viton®) **CAG-...-T-V-W66-K**
- * Kit with DB including Metric bolts 10.9, spring rings, O-ring made of NBR (Buna-N®) **CAG-...-T-MH-W130-K**
- * Kit with DB including UNC bolts (Grade 8), spring rings, O-ring made of NBR (Buna-N®) **CAG-...-T-U-W130-K**

¹ The maximum working pressure PN (bar/PSI) applies only to the flange itself and depends on the bolts used (Grade 8.8 / 10.9). The actual maximum working pressure depends on the thickness and the quality of the tube used.

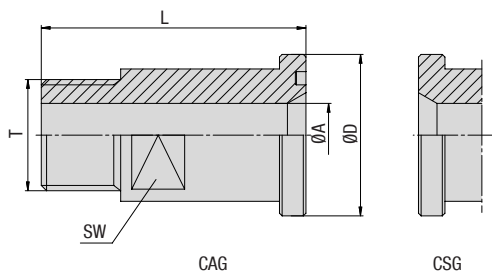

**SAE Flange / Counterflange Adaptor with Male BSPT Thread
Type CAG/CSG-BSPT - 6000 PSI Series**

B
6000 PSI High Pressure Series (according to ISO 6162-2:2002)

Nominal Size	DN	(in)	PN ¹ (bar/PSI)		Dimensions (mm/in)				Weight (kg/lbs) ca. per 100	Ordering Codes	
			8.8	10.9 (MH)	ØA	ØD	L	SW			T (BSPT)
13	1/2		350	350	12	31,8	50	19	1/2	12,5	CAG-601-T-W66
			5075	5075	.47	1.25	1.97	.75		27.48	
13	1/2		350	350	10	31,8	50	19	3/8 (06)	12,5	CAG-601-T06-W66
			5075	5075	.39	1.25	1.97	.75		27.48	
19	3/4		350	350	17	41,3	60	26	3/4	23,4	CAG-602-T-W66
			5075	5075	.67	1.63	2.36	1.02		51.51	
19	3/4		350	350	12	41,3	60	26	1/2 (08)	23,4	CAG-602-T08-W66
			5075	5075	.47	1.63	2.36	1.02		51.51	
25	1		350	350	22	47,6	70	32	1	35,9	CAG-603-T-W66
			5075	5075	.87	1.87	2.76	1.26		79.04	
25	1		350	350	17	47,6	70	32	3/4 (12)	35,9	CAG-603-T12-W66
			5075	5075	.67	1.87	2.76	1.26		79.04	
32	1-1/4		250	250	27	54	75	36	1-1/4	52,4	CAG-604-T-W66 ²
			3625	3625	1.06	2.13	2.95	1.42		115.28	
32	1-1/4		250	250	22	54	75	36	1 (16)	52,4	CAG-604-T16-W66
			3625	3625	.87	2.13	2.95	1.42		115.28	
38	1-1/2		250	250	30	63,5	80	41	1-1/2	76,0	CAG-605-T-W66
			3625	3625	1.18	2.50	3.15	1.61		167.20	
38	1-1/2		250	250	27	63,5	80	41	1-1/4 (20)	76,0	CAG-605-T20-W66
			3625	3625	1.06	2.50	3.15	1.61		167.20	
51	2		200	200	40	79,4	90	55	2	141,8	CAG-606-T-W66
			2900	2900	1.57	3.13	3.54	2.17		311.96	
51	2		200	200	30	79,4	90	55	1-1/2 (24)	141,8	CAG-606-T24-W66
			2900	2900	1.18	3.13	3.54	2.17		311.96	

¹ The maximum working pressure PN (bar/PSI) applies only to the flange itself and depends on the bolts used (Grade 8.8 / 10.9). The actual maximum working pressure depends on the thickness and the quality of the tube used.

² According to ISO 6162-2 bolts M12 should be used but because usually bolts M14 are used the description of the complete part must show M14 (e.g. CAG-604-T-**-**-M14#K).

Materials / Ordering Options / Examples

- * SAE Flange Adaptor (without O-ring) made of Steel S355J0 or equivalent, zinc-plated and thick-film-passivated **CAG-...-T-W66**
- * SAE Counterflange Adaptor made of Steel S355J0 or equivalent, zinc-plated and thick-film-passivated **CSG-...-T-W66**
- * SAE Flange Adaptor (without O-ring) made of Stainless Steel V4A – 1.4571 (on request) **CAG-...-T-W5**

- * Size of connection thread deviating from the standard (e.g. 1/2 BSPT) **CAG-...-T08-W66**

- * Kit with DB including Metric bolts 8.8, spring rings, O-ring made of NBR (Buna-N®) **CAG-...-T-W66-K**
- * Kit with DB including Metric bolts 8.8, spring rings, O-ring made of FKM/FPM (Viton®) **CAG-...-T-V-W66-K**
- * Kit with DB including Metric bolts 10.9, spring rings, O-ring made of NBR (Buna-N®) **CAG-...-T-MH-W130-K**
- * Kit with DB including UNC bolts (Grade 8), spring rings, O-ring made of NBR (Buna-N®) **CAG-...-T-U-W130-K**



**SAE Flange / Counterflange Adaptor with Male NPT Thread
Type CAG/CSG-N • 3000 PSI Series**

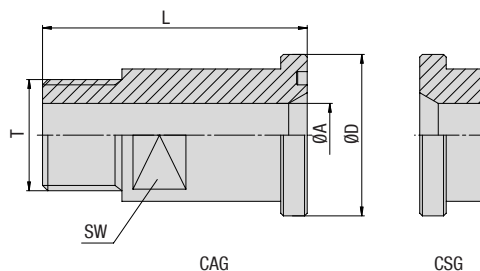

B

3000 PSI Standard Pressure Series (according to ISO 6162-1:2002)

Nominal Size		PN ¹ (bar/PSI)		Dimensions (mm/in)				Weight (kg/lbs) ca. per 100	Ordering Codes	
DN	(in)	8.8	10.9 (MH)	ØA	ØD	L	SW	T (NPT)		
13	1/2	300	300	12	30,2	50	19	1/2	13,0	CAG-301-N-W66
		4350	4350	.47	1.19	1.97	.75		28,60	
13	1/2	300	300	10	30,2	50	19	3/8 (06)	13,0	CAG-301-N06-W66
		4350	4350	.39	1.19	1.97	.75		28,60	
19	3/4	300	300	17	38,1	55	27	3/4	23,0	CAG-302-N-W66
		4350	4350	.67	1.50	2.17	1.06		50,60	
19	3/4	300	300	12	38,1	55	27	1/2 (08)	23,0	CAG-302-N08-W66
		4350	4350	.47	1.50	2.17	1.06		50,60	
25	1	300	300	22	44,45	60	32	1	28,0	CAG-303-N-W66
		4350	4350	.87	1.75	2.36	1.26		61,60	
25	1	300	300	17	44,45	60	32	3/4 (12)	28,0	CAG-303-N12-W66
		4350	4350	.67	1.75	2.36	1.26		61,60	
32	1-1/4	150	150	27	50,8	65	41	1-1/4	79,0	CAG-304-N-W66
		2175	2175	1.06	2.00	2.56	1.61		173,80	
32	1-1/4	150	150	22	50,8	65	41	1 (16)	79,0	CAG-304-N16-W66
		2175	2175	.87	2.00	2.56	1.61		173,80	
38	1-1/2	150	150	32	60,3	70	46	1-1/2	62,0	CAG-305-N-W66
		2175	2175	1.26	2.37	2.76	1.81		136,40	
38	1-1/2	150	150	27	60,3	70	46	1-1/4 (20)	62,0	CAG-305-N20-W66
		2175	2175	1.06	2.37	2.76	1.81		136,40	
51	2	150	150	40	71,4	75	55	2	95,8	CAG-306-N-W66
		2175	2175	1.57	2.81	2.95	2.17		210,76	
51	2	150	150	30	71,4	75	55	1-1/2 (24)	171,6	CAG-306-N24-W66
		2175	2175	1.18	2.81	2.95	2.17		377,52	

Materials / Ordering Options / Examples

- * SAE Flange Adaptor (without O-ring) made of Steel S355J0 or equivalent, zinc-plated and thick-film-passivated **CAG-...-N-W66**
- * SAE Counterflange Adaptor made of Steel S355J0 or equivalent, zinc-plated and thick-film-passivated **CSG-...-N-W66**
- * SAE Flange Adaptor (without O-ring) made of Stainless Steel V4A – 1.4571 (on request) **CAG-...-N-W5**

- * Size of connection thread deviating from the standard (e.g. 1/2 NPT) **CAG-...-N08-W66**

- * Kit with DB including Metric bolts 8.8, spring rings, O-ring made of NBR (Buna-N®) **CAG-...-N-W66-K**
- * Kit with DB including Metric bolts 8.8, spring rings, O-ring made of FKM/FPM (Viton®) **CAG-...-N-V-W66-K**
- * Kit with DB including Metric bolts 10.9, spring rings, O-ring made of NBR (Buna-N®) **CAG-...-N-MH-W130-K**
- * Kit with DB including UNC bolts (Grade 8), spring rings, O-ring made of NBR (Buna-N®) **CAG-...-N-U-W130-K**

¹ The maximum working pressure PN (bar/PSI) applies only to the flange itself and depends on the bolts used (Grade 8.8 / 10.9). The actual maximum working pressure depends on the thickness and the quality of the tube used.

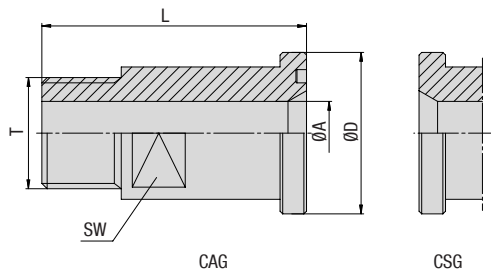

**SAE Flange Adaptor / Counterflange with Male NPT Thread
Type CAG/CSG-NPT • 6000 PSI Series**

B
6000 PSI High Pressure Series (according to ISO 6162-2:2002)

Nominal Size	PN ¹ (bar/PSI)	Dimensions (mm/in)				L	SW	T (NPT)	Weight (kg/lbs) ca. per 100	Ordering Codes
		DN	(in)	8.8	10.9 (MH)					
13	1/2	350	350	12	31,8	50	19	1/2	13,0	CAG-601-N-W66
		5075	5075	.47	1.25	1.97	.75		28.60	
13	1/2	350	350	10	31,8	50	19	3/8 (06)	13,0	CAG-601-N06-W66
		5075	5075	.39	1.25	1.97	.75		28.60	
19	3/4	350	350	17	41,3	60	26	3/4	23,0	CAG-602-N-W66
		5075	5075	.67	1.63	2.36	1.02		50.60	
19	3/4	350	350	12	41,3	60	26	1/2 (08)	23,0	CAG-602-N08-W66
		5075	5075	.47	1.63	2.36	1.02		50.60	
25	1	350	350	22	47,6	70	32	1	55,6	CAG-603-N-W66
		5075	5075	.87	1.87	2.76	1.26		122.32	
25	1	350	350	17	47,6	70	32	3/4 (12)	55,6	CAG-604-N12-W66
		5075	5075	.67	1.87	2.76	1.26		122.32	
32	1-1/4	250	250	27	54	75	36	1-1/4	56,6	CAG-604-N-W66 ²
		3625	3625	1.06	2.13	2.95	1.42		124.46	
32	1-1/4	250	250	22	54	75	36	1 (16)	56,6	CAG-604-N16-W66
		3625	3625	.87	2.13	2.95	1.42		124.46	
38	1-1/2	250	250	30	63,5	80	41	1-1/2	76,7	CAG-605-N-W66
		3625	3625	1.18	2.50	3.15	1.61		168.74	
38	1-1/2	250	250	27	63,5	80	41	1-1/4 (20)	83,2	CAG-605-N20-W66
		3625	3625	1.06	2.50	3.15	1.61		183.03	
51	2	200	200	40	79,4	90	55	2	174,6	CAG-606-N-W66
		2900	2900	1.57	3.13	3.54	2.17		384.12	
51	2	200	200	30	79,4	90	55	1-1/2 (24)	174,6	CAG-606-N24-W66
		2900	2900	1.18	3.13	3.54	2.17		384.12	

¹ The maximum working pressure PN (bar/PSI) applies only to the flange itself and depends on the bolts used (Grade 8.8 / 10.9). The actual maximum working pressure depends on the thickness and the quality of the tube used.

² According to ISO 6162-2 bolts M12 should be used but because usually bolts M14 are used the description of the complete part must show M14 (e.g. CAG-604-N-*/**/***-M14#K).

Materials / Ordering Options / Examples

- * SAE Flange Adaptor (without O-ring) made of Steel S355J0 or equivalent, zinc-plated and thick-film-passivated **CAG-...-N-W66**
- * SAE Counterflange Adaptor made of Steel S355J0 or equivalent, zinc-plated and thick-film-passivated **CSG-...-N-W66**
- * SAE Flange Adaptor (without O-ring) made of Stainless Steel V4A – 1.4571 (on request) **CAG-...-N-W5**

- * Size of connection thread deviating from the standard (e.g. 1/2 NPT) **CAG-...-N08-W66**

- * Kit with DB including Metric bolts 8.8, spring rings, O-ring made of NBR (Buna-N®) **CAG-...-N-W66-K**
- * Kit with DB including Metric bolts 8.8, spring rings, O-ring made of FKM/FPM (Viton®) **CAG-...-N-V-W66-K**
- * Kit with DB including Metric bolts 10.9, spring rings, O-ring made of NBR (Buna-N®) **CAG-...-N-MH-W130-K**
- * Kit with DB including UNC bolts (Grade 8), spring rings, O-ring made of NBR (Buna-N®) **CAG-...-N-U-W130-K**



SAE Flange Adaptor with Male Metric Thread and 24° Conical Bore (Shape W acc. to DIN 3861) Type CAG-L/S • 3000 PSI Series

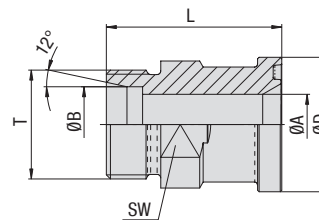

3000 PSI Standard Pressure Series (according to ISO 6162-1:2002)

Nominal Size	DN	(in)	PN ¹ (bar/PSI)		Dimensions (mm/in)		Series	ØD	L	SW	T (Metric)	Weight (kg/lbs) Ca. per 100	Ordering Codes
			8.8	10.9 (MH)	ØA	ØB							
13	1/2		315	315	12	15	L	30,2	48	24	22x1,5	12,6	CAG-301-15L-W66
			4568	4568	.47	.59		1.19	1.89	.94		27.72	
13	1/2		350	350	12	16	S	30,2	50	24	24x1,5	13,0	CAG-301-16S-W66
			5075	5075	.47	.63		1.19	1.97	.94		28.60	
19	3/4		315	315	15	18	L	38,1	53	30	26x1,5	23,1	CAG-302-18L-W66
			4568	4568	.59	.71		1.50	2.09	1.18		50.71	
19	3/4		350	350	16	20	S	38,1	57	30	30x2	24,2	CAG-302-20S-W66
			5075	5075	.63	.79		1.50	2.24	1.18		53.24	
19	3/4		160	160	19	22	L	38,1	53	30	30x2	20,1	CAG-302-22L-W66
			2320	2320	.75	.87		1.50	2.09	1.18		44.11	
19	3/4		350	350	17	25	S	38,1	57	30	36x2	25,6	CAG-302-25S-W66
			5075	5075	.67	.98		1.50	2.24	1.18		56.36	
19	3/4		160	160	19	28	L	38,1	53	30	36x2	21,7	CAG-302-28L-W66
			2320	2320	.75	1.10		1.50	2.09	1.18		47.81	
25	1		250	315	20	25	S	44,45	58	36	36x2	34,5	CAG-303-25S-W66
			3625	4568	.79	.98		1.75	2.28	1.42		75.90	
25	1		160	160	24	28	L	44,45	54	36	36x2	28,3	CAG-303-28L-W66
			2320	2320	.94	1.10		1.75	2.13	1.42		62.26	
25	1		250	315	24	30	S	44,45	63	36	42x2	35,2	CAG-303-30S-W66
			3625	4568	.94	1.18		1.75	2.48	1.42		77.44	
32	1-1/4		200	250	20	25	S	50,8	60	41	36x2	46,6	CAG-304-25S-W66
			2900	3625	.79	.98		2.00	2.36	1.61		102.52	
32	1-1/4		160	160	22	28	L	50,8	59	41	36x2	43,5	CAG-304-28L-W66
			2320	2320	.87	1.10		2.00	2.32	1.61		95.80	
32	1-1/4		200	250	25	30	S	50,8	62	41	42x2	44,8	CAG-304-30S-W66
			2900	3625	.98	1.18		2.00	2.44	1.61		98.56	
32	1-1/4		160	160	30	35	L	50,8	58	41	45x2	35,9	CAG-304-35L-W66
			2320	2320	1.18	1.38		2.00	2.28	1.61		78.98	
32	1-1/4		200	250	28	38	S	50,8	67	46	52x2	54,4	CAG-304-38S-W66
			2900	3625	1.10	1.50		2.00	2.64	1.81		119.68	
38	1-1/2		200	200	32	38	S	60,35	70	46	52x2	62,3	CAG-305-38S-W66
			2900	2900	1.26	1.50		2.38	2.76	1.81		137.06	
38	1-1/2		160	160	36	42	L	60,35	64	46	52x2	47,7	CAG-305-42L-W66
			2320	2320	1.42	1.65		2.38	2.52	1.81		104.90	

Materials / Ordering Options / Examples

- * SAE Flange Adaptor (without O-ring) made of Steel S355J0 or equivalent, zinc-plated and thick-film-passivated **CAG-...-...-W66**
- * SAE Flange Adaptor (without O-ring) made of Steel S355J0 / C45 or equivalent, zinc/nickel-plated (on request) **CAG-...-...-W3**
- * SAE Flange Adaptor (without O-ring) made of Stainless Steel V4A – 1.4571 (on request) **CAG-...-...-W5**
- * Kit with DB including Metric bolts 8.8, spring rings, O-ring made of NBR (Buna-N®) **CAG-...-...-W66-K**
- * Kit with DB including Metric bolts 8.8, spring rings, O-ring made of FKM/FPM (Viton®) **CAG-...-...-V-W66-K**
- * Kit with DB including Metric bolts 10.9, spring rings, O-ring made of NBR (Buna-N®) **CAG-...-...-MH-W130-K**
- * Kit with DB including UNC bolts (Grade 8), spring rings, O-ring made of NBR (Buna-N®) **CAG-...-...-U-W130-K**

Please always indicate ØB and Series.

¹ The maximum working pressure PN (bar/PSI) applies only to the flange itself and depends on the bolts used (Grade 8.8 / 10.9). The actual maximum working pressure depends on the thickness and the quality of the tube used.

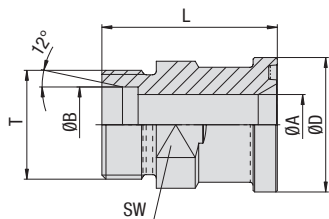

SAE Flange Adaptor with Male Metric Thread and 24° Conical Bore (Shape W acc. to DIN 3861) Type CAG-L/S • 6000 PSI Series

B

6000 PSI High Pressure Series (according to ISO 6162-2:2002)

Nominal Size		PN ¹ (bar/PSI)		Dimensions (mm/in)			Series	ØD	L	SW	T (Metric)	Weight (kg/lbs) ca. per 100	Ordering Codes
DN	(in)	8.8	10.9 (MH)	ØA	ØB								
13	1/2	350	420	12	16		31,8	53	24		24x1,5	1,5	CAG-601-16S-W66
		5075	6090	.47	.63		1.25	2.09	.94			3.30	
19	3/4	350	420	12	16		41,3	59	30		24x1,5	29,5	CAG-602-16S-W66
		5075	6090	.47	.63		1.63	2.32	1.18			64.90	
19	3/4	350	400	16	20		41,3	61	30		30x2	28,5	CAG-602-20S-W66
		5075	5800	.63	.79		1.63	2.40	1.18			62.74	
19	3/4	350	400	17	25		41,3	63	30		36x2	30,4	CAG-602-25S-W66
		5075	5800	.67	.98		1.63	2.48	1.18			66.84	
19	3/4	350	400	18	30		41,3	64	36		42x2	36,8	CAG-602-30S-W66
		5075	5800	.71	1.18		1.63	2.52	1.42			80.96	
25	1	350	400	20	25		47,6	72	36		36x2	49,8	CAG-603-25S-W66
		5075	5800	.79	.98		1.87	2.83	1.42			109.56	
25	1	350	400	24	30		47,6	74	36		42x2	47,7	CAG-603-30S-W66
		5075	5800	.94	1.18		1.87	2.91	1.42			104.94	
32	1-1/4	350	400	25	30		54	79	41		42x2	62,1	CAG-604-30S-W66 ²
		5075	5800	.98	1.18		2.13	3.11	1.61			136.62	
32	1-1/4	350	350	30	38		54	83	46		52x2	66,1	CAG-604-38S-W66 ²
		5075	5075	1.18	1.50		2.13	3.27	1.81			145.42	
38	1-1/2	350	350	30	38		63,5	89	46		52x2	92,2	CAG-605-38S-W66
		5075	5075	1.18	1.50		2.50	3.50	1.81			202.77	

¹ The maximum working pressure PN (bar/PSI) applies only to the flange itself and depends on the bolts used (Grade 8.8 / 10.9). The actual maximum working pressure depends on the thickness and the quality of the tube used.

² According to ISO 6162-2 bolts M12 should be used but because usually bolts M14 are used the description of the complete part must show M14 (e.g. CAG-604-S30-M14#K).

Materials / Ordering Options / Examples

- * SAE Flange Adaptor (without O-ring) made of Steel S355J0 or equivalent, zinc-plated and thick-film-passivated **CAG-...-...-W66**
- * SAE Flange Adaptor (without O-ring) made of Steel S355J0 / C45 or equivalent, zinc/nickel-plated (on request) **CAG-...-...-W3**
- * SAE Flange Adaptor (without O-ring) made of Stainless Steel V4A – 1.4571 (on request) **CAG-...-...-W5**

- * Kit with DB including Metric bolts 8.8, spring rings, O-ring made of NBR (Buna-N®) **CAG-...-...-W66-K**
- * Kit with DB including Metric bolts 8.8, spring rings, O-ring made of FKM/FPM (Viton®) **CAG-...-...-V-W66-K**
- * Kit with DB including Metric bolts 10.9, spring rings, O-ring made of NBR (Buna-N®) **CAG-...-...-MH-W130-K**
- * Kit with DB including UNC bolts (Grade 8), spring rings, O-ring made of NBR (Buna-N®) **CAG-...-...-U-W130-K**

Please always indicate ØB and Series.



SAE 90° Butt-Weld Flange Adaptor Type CAG90-ST • 3000 PSI Series

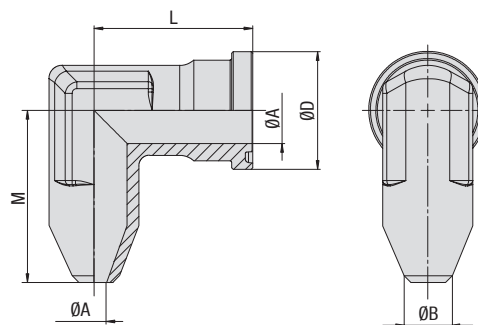

3000 PSI Standard Pressure Series (according to ISO 6162-1:2002)

Nominal Size	DN	(in)	PN ¹ (bar/PSI)		Dimensions (mm/in)				Weight (kg/lbs) ca. per 100	Ordering Codes	
			8.8	10.9 (MH)	ØA	ØB	ØD	L			M
13	1/2		350	350	11	15	30,2	39	38	16,0	CAG90-301-ST-15/11-W1
			5075	5075	.43	.59	1.19	1.54	1.50	35.20	
13	1/2		350	350	12	16	30,2	39	38	17,9	CAG90-301-ST-16/12-W1
			5075	5075	.47	.63	1.19	1.54	1.50	39.34	
13	1/2		350	350	14	21,3	30,2	39	38	17,0	CAG90-301-ST-21.3/14-W1
			5075	5075	.55	.84	1.19	1.54	1.50	37.40	
19	3/4		350	350	15	18	38,1	42	45	66,0	CAG90-302-ST-18/15-W1
			5075	5075	.59	.71	1.50	1.65	1.77	145.20	
19	3/4		350	350	14	20	38,1	42	45	35,4	CAG90-302-ST-20/14-W1
			5075	5075	.55	.79	1.50	1.65	1.77	77.96	
19	3/4		350	350	16	22	38,1	42	45	29,0	CAG90-302-ST-22/16-W1
			5075	5075	.63	.87	1.50	1.65	1.77	63.80	
19	3/4		350	350	19	26,9	38,1	42	45	30,0	CAG90-302-ST-26.9/19-W1
			5075	5075	.75	1.06	1.50	1.65	1.77	66.00	
25	1		250	315	19	25	44,45	45	50	82,1	CAG90-303-ST-25/19-W1
			3625	4568	.75	.98	1.75	1.77	1.97	180.62	
25	1		250	315	22	30	44,45	45	50	50,3	CAG90-303-ST-30/22-W1
			3625	4568	.87	1.18	1.75	1.77	1.97	110.66	
25	1		250	315	25	33,7	44,45	45	50	41,0	CAG90-303-ST-33.7/25-W1
			3625	4568	.98	1.33	1.75	1.77	1.97	90.20	
32	1-1/4		200	250	19	25	50,8	50	59	117,2	CAG90-304-ST-25/19-W1
			2900	3625	.75	.98	2.00	1.97	2.32	257.84	
32	1-1/4		200	250	22	30	50,8	50	59	35,0	CAG90-304-ST-30/22-W1
			2900	3625	.87	1.18	2.00	1.97	2.32	77.00	
32	1-1/4		200	250	31	35	50,8	50	59	52,4	CAG90-304-ST-35/31-W1
			2900	3625	1.22	1.38	2.00	1.97	2.32	115.28	
32	1-1/4		200	250	28	38	50,8	50	59	97,0	CAG90-304-ST-38/28-W1
			2900	3625	1.10	1.50	2.00	1.97	2.32	213.40	
32	1-1/4		200	250	32	42,4	50,8	50	59	71,0	CAG90-304-ST-42.4/32-W1
			2900	3625	1.26	1.67	2.00	1.97	2.32	156.20	
38	1-1/2		200	200	28	38	60,35	76	56	75,0	CAG90-305-ST-38/28-W1
			2900	2900	1.10	1.50	2.38	2.99	2.20	165.00	
38	1-1/2		200	200	36	42	60,35	76	56	70,9	CAG90-305-ST-42/36-W1
			2900	2900	1.42	1.65	2.38	2.99	2.20	155.98	
38	1-1/2		200	200	38	48,3	60,35	76	56	65,0	CAG90-305-ST-48.3/38-W1
			2900	2900	1.50	1.90	2.38	2.99	2.20	143.00	

Materials / Ordering Options / Examples

- * SAE Flange Adaptor (without O-ring) made of Steel S355J0 or equivalent, blank (oiled)
- * SAE Flange Adaptor (without O-ring) made of Stainless Steel V4A – 1.4404 (on request)

CAG90-...-ST-**-**-W1
CAG90-...-ST-**-**-W5

- * Kit with DB including Metric bolts 8.8, spring rings, O-ring made of NBR (Buna-N®)
- * Kit with DB including Metric bolts 8.8, spring rings, O-ring made of FKM/FPM (Viton®)
- * Kit with DB including Metric bolts 10.9, spring rings, O-ring made of NBR (Buna-N®)
- * Kit with DB including UNC bolts (Grade 8), spring rings, O-ring made of NBR (Buna-N®)

CAG90-...-ST-**-**-W57-K
CAG90-...-ST-**-**-V-W57-K
CAG90-...-ST-**-**-MH-W129-K
CAG90-...-ST-**-**-U-W129-K

Please always indicate ØB / ØA.

¹ The maximum working pressure PN (bar/PSI) applies only to the flange itself and depends on the bolts used (Grade 8.8 / 10.9). The actual maximum working pressure depends on the thickness and the quality of the tube used.

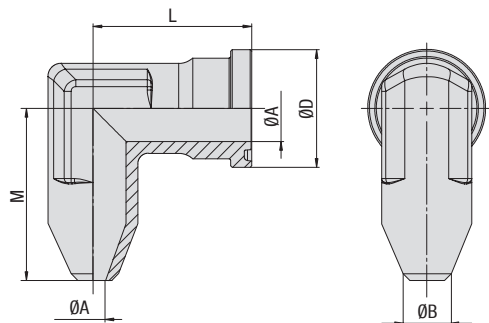

**SAE 90° Butt-Weld Flange Adaptor
Type CAG90-ST - 6000 PSI Series**

B
6000 PSI High Pressure Series (according to ISO 6162-2:2002)

Nominal Size	PN ¹ (bar/PSI)	Dimensions (mm/in)							Weight (^{kg} /lb) ca. per 100	Ordering Codes
		8.8	10.9 (MH)	ØA	ØB	ØD	L	M		
13	1/2	350	420	10	16	31,8	39	38	20,7	CAG90-601-ST-16/10-W1
		5075	6090	.39	.63	1.25	1.54	1.50	45.54	
13	1/2	350	420	12	21,3	31,8	39	38	20,7	CAG90-601-ST-21.3/12-W1
		5075	6090	.47	.84	1.25	1.54	1.50	45.54	
19	3/4	350	420	10	16	41,3	48	48	89,5	CAG90-602-ST-16/10-W1
		5075	6090	.39	.63	1.63	1.89	1.89	196.90	
19	3/4	350	420	12	20	41,2	48	48	46,0	CAG90-602-ST-20/12-W1
		5075	6090	.47	.79	1.62	1.89	1.89	101.15	
19	3/4	350	420	17	25	41,3	48	48	43,1	CAG90-602-ST-25/17-W1
		5075	6090	.67	.98	1.63	1.89	1.89	94.82	
19	3/4	350	420	16	26,9	41,3	48	48	43,6	CAG90-602-ST-26.9/16-W1
		5075	6090	.63	1.06	1.63	1.89	1.89	95.92	
25	1	350	420	17	25	47,6	60	60	73,0	CAG90-603-ST-25/17-W1
		5075	6090	.67	.98	1.87	2.36	2.36	160.60	
25	1	350	420	22	60	47,6	60	60	74,9	CAG90-603-ST-30/22-W1
		5075	6090	.87	1.18	1.87	2.36	2.36	164.78	
25	1	350	420	25	33,7	47,6	60	60	63,0	CAG90-603-ST-33.7/25-W1
		5075	6090	.98	1.33	1.87	2.36	2.36	138.60	
25	1	350	420	21	33,7	47,6	60	60	69,1	CAG90-603-ST-33.7/21-W1
		5075	6090	.83	1.33	1.87	2.36	2.36	152.02	
32	1-1/4	350	420	22	60	54	68	68	89,0	CAG90-604-ST-30/22-W1 ²
		5075	6090	.87	1.18	2.13	2.68	2.68	195.80	
32	1-1/4	350	420	28	38	54	68	68	94,3	CAG90-604-ST-38/28-W1 ²
		5075	6090	1.10	1.50	2.13	2.68	2.68	207.46	
32	1-1/4	350	420	60	42,4	54	68	68	92,1	CAG90-604-ST-42.4/30-W1 ²
		5075	6090	1.18	1.67	2.13	2.68	2.68	202.62	
32	1-1/4	350	420	22	38	54	68	68	109,4	CAG90-604-ST-38/22-W1 ²
		5075	6090	.87	1.50	2.13	2.68	2.68	240.68	
38	1-1/2	350	420	28	38	63,5	76	76	167,2	CAG90-605-ST-38/28-W1
		5075	6090	1.10	1.50	2.50	2.99	2.99	367.84	
38	1-1/2	350	420	22	38	63,5	76	76	146,6	CAG90-605-ST-38/22-W1
		5075	6090	.87	1.50	2.50	2.99	2.99	322.52	
38	1-1/2	350	420	34	48,3	63,6	76	76	148,6	CAG90-605-ST-48.3/34-W1
		5075	6090	1.34	1.90	2.50	2.99	2.99	326.92	
38	1-1/2	350	420	32	48,3	63,5	76	76	148,6	CAG90-605-ST-48.3/32-W1
		5075	6090	1.26	1.90	2.50	2.99	2.99	326.92	

¹ The maximum working pressure PN (bar/PSI) applies only to the flange itself and depends on the bolts used (Grade 8.8 / 10.9). The actual maximum working pressure depends on the thickness and the quality of the tube used.

² According to ISO 6162-2 bolts M12 should be used but because usually bolts M14 are used the description of the complete part must show M14 (CAG90-604-ST-30/22-M14#K).

Materials / Ordering Options / Examples

- * SAE Flange Adaptor (without O-ring) made of Steel S355J0 or equivalent, blank (oiled) **CAG90-...-ST-**-**/**-W1**
- * SAE Flange Adaptor (without O-ring) made of Stainless Steel V4A – 1.4404 (on request) **CAG90-...-ST-**-**/**-W5**
- * Kit with DB including Metric bolts 8.8, spring rings, O-ring made of NBR (Buna-N®) **CAG90-...-ST-**-**/**-W57-K**
- * Kit with DB including Metric bolts 8.8, spring rings, O-ring made of FKM/FPM (Viton®) **CAG90-...-ST-**-**/**-V-W57-K**
- * Kit with DB including Metric bolts 10.9, spring rings, O-ring made of NBR (Buna-N®) **CAG90-...-ST-**-**/**-MH-W129-K**
- * Kit with DB including UNC bolts (Grade 8), spring rings, O-ring made of NBR (Buna-N®) **CAG90-...-ST-**-**/**-U-W129-K**

Please always indicate ØB / ØA.



**SAE 90° Flange Adaptor with Male Metric Thread and 24° Conical Bore (Shape W acc. to DIN 3861)
Type CAG90-L/S • 3000 PSI Series**

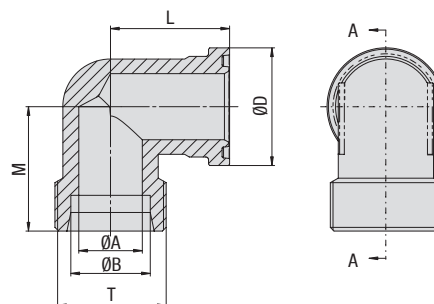

3000 PSI Standard Pressure Series (according to ISO 6162-1:2002)

Nominal Size	DN	(in)	PN ¹ (bar/PSI)		Dimensions (mm/in)		Series	ØD	L	M	T (Metric)	Weight (kg/lbs) Ca. per 100	Ordering Codes
			8.8	10.9 (MH)	ØA	ØB							
13	1/2		315	315	12	15	L	30,2	39	36	22x1,5	16,4	CAG90-301-15L-W66
			4568	4568	.47	.59		1.19	1.54	1.42	36.08		
13	1/2		350	350	12	16	S	30,2	39	38	24x1,5	17,2	CAG90-301-16S-W66
			5075	5075	.47	.63		1.19	1.54	1.50	37.84		
19	3/4		315	315	15	18	L	38,1	42	39	26x1,5	30,2	CAG90-302-18L-W66
			4568	4568	.59	.71		1.50	1.65	1.54	66.44		
19	3/4		350	350	16	20	S	38,1	42	43	30x2	33,4	CAG90-302-20S-W66
			5075	5075	.63	.79		1.50	1.65	1.69	73.48		
19	3/4		160	160	19	22	L	38,1	42	41	30x2	28,8	CAG90-302-22L-W66
			2320	2320	.75	.87		1.50	1.65	1.61	63.36		
19	3/4		350	350	17	25	S	38,1	42	45	36x2	35,6	CAG90-302-25S-W66
			5075	5075	.67	.98		1.50	1.65	1.77	78.32		
25	1		250	315	20	25	S	44,45	45	48,5	36x2	52,3	CAG90-303-25S-W66
			3625	4568	.79	.98		1.75	1.77	1.91	115.06		
25	1		160	160	24	28	L	44,45	45	45,5	36x2	40,7	CAG90-303-28L-W66
			2320	2320	.94	1.10		1.75	1.77	1.79	89.54		
25	1		250	315	24	30	S	44,45	45	50	42x2	47,2	CAG90-303-30S-W66
			3625	4568	.94	1.18		1.75	1.77	1.97	103.84		
32	1-1/4		200	250	20	25	S	50,8	50	55	36x2	70,8	CAG90-304-25S-W66
			2900	3625	.79	.98		2.00	1.97	2.17	155.76		
32	1-1/4		200	250	25	30	S	50,8	50	57	42x2	67,5	CAG90-304-30S-W66
			2900	3625	.98	1.18		2.00	1.97	2.24	148.50		
32	1-1/4		160	160	30	38	L	50,8	50	57	45x2	56,5	CAG90-304-35L-W66
			2320	2320	1.18	1.50		2.00	1.97	2.24	124.30		
32	1-1/4		200	250	28	38	S	50,8	50	59	52x2	71,5	CAG90-304-38S-W66
			2900	3625	1.10	1.50		2.00	1.97	2.32	157.30		
38	1-1/2		200	200	32	38	S	60,35	55	64	52x2	138,4	CAG90-305-38S-W66
			2900	2900	1.26	1.50		2.38	2.17	2.52	304.48		
38	1-1/2		160	160	36	42	L	60,35	55	58	52x2	75,4	CAG90-305-42L-W66
			2320	2320	1.42	1.65		2.38	2.17	2.28	165.93		

Materials / Ordering Options / Examples

- * SAE Flange Adaptor (without O-ring) made of Steel S355J0 or equivalent, zinc-plated and thick-film-passivated **CAG90-...-W66**
- * SAE Flange Adaptor (without O-ring) made of Steel S355J0 / C45 or equivalent, zinc/nickel-plated (on request) **CAG90-...-W3**
- * SAE Flange Adaptor (without O-ring) made of Stainless Steel V4A – 1.4404 (on request) **CAG90-...-W5**

- * Kit with DB including Metric bolts 8.8, spring rings, O-ring made of NBR (Buna-N®) **CAG90-...-W66-K**
- * Kit with DB including Metric bolts 8.8, spring rings, O-ring made of FKM/FPM (Viton®) **CAG90-...-V-W66-K**
- * Kit with DB including Metric bolts 10.9, spring rings, O-ring made of NBR (Buna-N®) **CAG90-...-MH-W130-K**
- * Kit with DB including UNC bolts (Grade 8), spring rings, O-ring made of NBR (Buna-N®) **CAG90-...-U-W130-K**

Please always indicate ØB and Series.

¹ The maximum working pressure PN (bar/PSI) applies only to the flange itself and depends on the bolts used (Grade 8.8 / 10.9). The actual maximum working pressure depends on the thickness and the quality of the tube used.

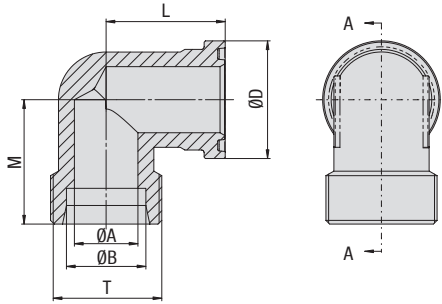

**SAE 90° Flange Adaptor with Male Metric Thread and 24° Conical Bore (Shape W acc. to DIN 3861)
Type CAG90-L/S • 6000 PSI Series**

B

6000 PSI High Pressure Series (according to ISO 6162-2:2002)

Nominal Size	DN	(in)	PN ¹ (bar/PSI)		Dimensions (mm/in)						Weight (kg/lbs) Ca. per 100	Ordering Codes
			8.8	10.9 (MH)	ØA	ØB	ØD	L	M	T (Metric)		
13	1/2		350	420	12	16	31,8	39	37,9	24x1,5	18,9	CAG90-601-16S-W66
			5075	6090	.47	.63	1,25	1.54	1.49		41.58	
19	3/4		350	420	12	16	41,3	48	45	24x1,5	42,3	CAG90-602-16S-W66
			5075	6090	.47	.63	1,63	1.89	1.77		93.06	
19	3/4		350	400	16	20	41,3	48	46	30x2	43,0	CAG90-602-20S-W66
			5075	5800	.63	.79	1,63	1.89	1.81		94.60	
19	3/4		350	400	17	25	41,3	48	48	36x2	43,6	CAG90-602-25S-W66
			5075	5800	.67	.98	1,63	1.89	1.89		95.92	
25	1		350	400	20	25	47,6	60	53	36x2	73,4	CAG90-603-25S-W66
			5075	5800	.79	.98	1,87	2.36	2.09		161.48	
25	1		350	400	24	30	47,6	60	55	42x2	63,2	CAG90-603-30S-W66
			5075	5800	.94	1.18	1,87	2.36	2.17		139.04	
32	1-1/4		350	400	25	30	54	68	58	42x2	89,3	CAG90-604-30S-W66 ²
			5075	5800	.98	1.18	2,13	2.68	2.28		196.46	
32	1-1/4		350	350	30	38	54	68	61	52x2	88,7	CAG90-604-38S-W66 ²
			5075	5075	1.18	1.50	2,13	2.68	2.40		195.14	
38	1-1/2		350	350	25	30	63,5	76	72	42x2	177,2	CAG90-605-30S-W66
			5075	5075	.98	1.18	2,50	2.99	2.83		389.84	
38	1-1/2		350	350	30	38	63,5	76	72	52x2	147,1	CAG90-605-38S-W66
			5075	5075	1.18	1.50	2,50	2.99	2.83		323.62	

¹ The maximum working pressure PN (bar/PSI) applies only to the flange itself and depends on the bolts used (Grade 8.8 / 10.9). The actual maximum working pressure depends on the thickness and the quality of the tube used.

² According to ISO 6162-2 bolts M12 should be used but because usually bolts M14 are used the description of the complete part must show M14 (e.g. CAG90-604-S30-M14#K).























Materials / Ordering Options / Examples

- * SAE Flange Adaptor (without O-ring) made of Steel S355J0 or equivalent, zinc-plated and thick-film-passivated **CAG90-...-W66**
- * SAE Flange Adaptor (without O-ring) made of Steel S355J0 / C45 or equivalent, zinc/nickel-plated (on request) **CAG90-...-W3**
- * SAE Flange Adaptor (without O-ring) made of Stainless Steel V4A – 1.4404 (on request) **CAG90-...-W5**
- * Kit with DB including Metric bolts 8.8, spring rings, O-ring made of NBR (Buna-N®) **CAG90-...-W66-K**
- * Kit with DB including Metric bolts 8.8, spring rings, O-ring made of FKM/FPM (Viton®) **CAG90-...-V-W66-K**
- * Kit with DB including Metric bolts 10.9, spring rings, O-ring made of NBR (Buna-N®) **CAG90-...-MH-W130-K**
- * Kit with DB including UNC bolts (Grade 8), spring rings, O-ring made of NBR (Buna-N®) **CAG90-...-U-W130-K**

Please always indicate ØB and Series.





	SAE Single-Part Flange with Female BSPP Thread BFX-G	40		SAE 90° Single-Part Flange with Female BSPP Thread BFX90-G	71
	SAE Single-Part Counterflange with Female BSPP Thread BAS-G	42		SAE 90° Single-Part Flange with Female NPT Thread BFX90-N	72
	SAE Single-Part Flange with Female NPT Thread BFX-N	44		SAE 90° Single-Part Butt-Weld Flange for High Pressure Tubes BFX90-STC	73
	SAE Single-Part Counterflange with Female NPT Thread BAS-N	46		SAE 90° Single-Part Butt-Weld Flange for Metric Tubes BFX90-SRE	74
	SAE Single-Part Flange with Female UN/UNF Thread BFX-U	48		SAE 90° Single-Part Socket-Weld Flange BFX90-ES	76
	SAE Single-Part Butt-Weld Flange for High Pressure Tubes BFX-ST	50		SAE 90° Single-Part Flange with Male Metric Thread and 24° Conical Bore (Shape W acc. to DIN 3861) BFX90-L/S	78
	SAE Single-Part Butt-Weld Counterflange for High Pressure Tubes BAS-ST	52			
	SAE Single-Part Butt-Weld Flange for Low Pressure Tubes BFX-STRE	54			
	SAE Single-Part Butt-Weld Counterflange for Low Pressure Tubes BAS-STRE	55			
	SAE Single-Part Butt-Weld Flange for Metric Tubes BFX-SRE	56			
	SAE Single-Part Butt-Weld Counterflange for Metric Tubes BAS-SRE	58			
	SAE Single-Part Socket-Weld Flange BFX-ES	60			
	SAE Single-Part Socket-Weld Counterflange BAS-ES	62			
	SAE Single-Part Socket-Weld Flange (Flat Style) BFX-FL-ES	64			
	SAE Single-Part Socket-Weld Counterflange (Flat Style) BAS-FL-ES	65			
	SAE Single-Part Flange with Male Metric Thread and 24° Conical Bore (Shape W acc. to DIN 3861) BFX-L/S	66			
	SAE Single-Part Flange with Male BSPP Thread and 60° Conical Bore (acc. to BS 5200) BFX-B	68			
	SAE Single-Part Flange with Male UN/UNF Thread and 37° JIC Taper (acc. to ISO 8434-2 / SAE J514) BFX-J	70			

C



SAE Single-Part Flange with Female BSPP Thread
Type BFX-G • 3000 PSI Series

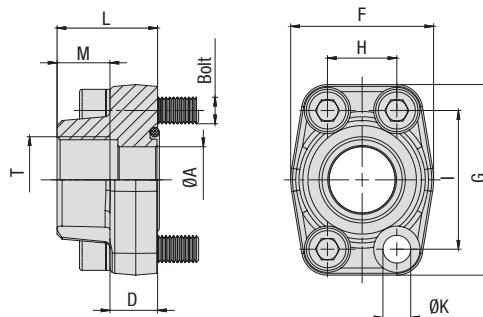

3000 PSI Standard Pressure Series (based on ISO 6162-1:2002)

Nominal Size	DN	(in)	PN ¹		Dimensions										Weight	for Bolts		Ordering Codes
			(bar/PSI)	(mm/in)	8.8	10.9 (MH)	ØA	D	F	G	H	I	L	M		T (BSPP)	ØK ³	
13	1/2	350	350	13	16	47	57	17,5	38,1	36	15	1/2	8,7	27,6	M8x30	5/16-18 UNC x 1-1/4	BFX-301-G-W1	
		5075	5075	.51	.63	1.85	2.24	.69	1.50	1.42	.59		.34	60.72				
13	1/2	350	350	13	16	47	57	17,5	38,1	36	20	3/8 (06)	8,7	29,3	M8x30	5/16-18 UNC x 1-1/4	BFX-301-G06-W1	
		5075	5075	.51	.63	1.85	2.24	.69	1.50	1.42	.79		.34	64.46				
19	3/4	350	350	19	18	50	67	22,3	47,6	36	18	3/4	10,5	38,6	M10x35	3/8-16 UNC x 1-1/2	BFX-302-G-W1	
		5075	5075	.75	.71	1.97	2.64	.88	1.87	1.42	.71		.41	84.92				
19	3/4	350	350	13	18	50	67	22,3	47,6	36	15	1/2 (08)	10,5	40,3	M10x35	3/8-16 UNC x 1-1/2	BFX-302-G08-W1	
		5075	5075	.51	.71	1.97	2.64	.88	1.87	1.42	.59		.41	88.66				
25	1	250	315	25	18	54	72	26,2	52,4	38	20	1	10,5	45,4	M10x35	3/8-16 UNC x 1-1/2	BFX-303-G-W1	
		3625	4568	.98	.71	2.13	2.83	1.03	2.06	1.50	.79		.41	99.88				
25	1	250	315	19	18	54	72	26,2	52,4	38	18	3/4 (12)	10,5	54,0	M10x35	3/8-16 UNC x 1-1/2	BFX-303-G12-W1	
		3625	4568	.75	.71	2.13	2.83	1.03	2.06	1.50	.71		.41	118.80				
32	1-1/4	200	250	31	21	68	82	30,2	58,7	41	22	1-1/4	11,5 (13,5)	67,9	M10x40 (M12x40)	7/16-14 UNC x 1-1/2	BFX-304-G-W1	
		2900	3625	1.22	.83	2.68	3.23	1.19	2.31	1.61	.87		.45 (53)	149.38				
32	1-1/4	200	250	25	21	68	82	30,2	58,7	41	20	1 (16)	11,5 (13,5)	85,5	M10x40 (M12x40)	7/16-14 UNC x 1-1/2	BFX-304-G16-W1	
		2900	3625	.98	.83	2.68	3.23	1.19	2.31	1.61	.79		.45 (53)	188.10				
38	1-1/2	200	200	38	25	79	96	35,7	69,9	44	24	1-1/2	13,5 (14,5)	113,9	M12x45 (M14x45)	1/2-13 UNC x 1-3/4	BFX-305-G-W1	
		2900	2900	1.50	.98	3.11	3.78	1.41	2.75	1.73	.94		.53 (57)	250.58				
38	1-1/2	200	200	31	25	79	96	35,7	69,9	44	22	1-1/4 (20)	13,5 (14,5)	119,7	M12x45 (M14x45)	1/2-13 UNC x 1-3/4	BFX-305-G20-W1	
		2900	2900	1.22	.98	3.11	3.78	1.41	2.75	1.73	.87		.53 (57)	263.34				
51	2	160	200	50	25,5	88	102	42,9	77,8	45	26	2	13,5 (14,5)	120,4	M12x45 (M14x45)	1/2-13 UNC x 1-3/4	BFX-306-G-W1	
		2320	2900	1.97	1.00	3.46	4.02	1.69	3.06	1.77	1.02		.53 (57)	264.88				
51	2	160	200	38	25,5	88	102	42,9	77,8	45	24	1-1/2 (24)	13,5 (14,5)	154,6	M12x45 (M14x45)	1/2-13 UNC x 1-3/4	BFX-306-G24-W1	
		2320	2900	1.50	1.00	3.46	4.02	1.69	3.06	1.77	.94		.53 (57)	340.12				
64	2-1/2	100	160	63	26	101	115	50,8	88,9	50	30	2-1/2	13,5 (14,5)	154,5	M12x45 (M14x45)	1/2-13 UNC x 1-3/4	BFX-307-G-W1	
		1450	2320	2.48	1.02	3.98	4.53	2.00	3.50	1.97	1.18		.53 (57)	339.90				
64	2-1/2	100	160	50	26	101	115	50,8	88,9	50	26	2 (32)	13,5 (14,5)	201,8	M12x45 (M14x45)	1/2-13 UNC x 1-3/4	BFX-307-G32-W1	
		1450	2320	1.97	1.02	3.98	4.53	2.00	3.50	1.97	1.02		.53 (57)	443.96				
76	3	100	160	73	27,5	127	137	61,9	106,4	50	30	3	17	215,0	M16x50	5/8-11 UNC x 2	BFX-308-G-W1	
		1450	2320	2.87	1.08	5.00	5.39	2.44	4.19	1.97	1.18		.67	473.00				
76	3	100	160	63	27,5	127	137	61,9	106,4	50	30	2-1/2 (40)	17	257,2	M16x50	5/8-11 UNC x 2	BFX-308-G40-W1	
		1450	2320	2.48	1.08	5.00	5.39	2.44	4.19	1.97	1.18		.67	565.84				
89	3-1/2	35	35	89	27,5	138	155	69,8	120,7	50	30	3-1/2	17	247,2	M16x50	5/8-11 UNC x 2	BFX-309-G-W1	
		508	508	3.50	1.08	5.43	6.10	2.75	4.75	1.97	1.18		.67	543.84				
102	4	35	35	99	27,5	147	163	77,8	130,2	50	30	4	17	292,5	M16x50	5/8-11 UNC x 2	BFX-310-G-W1	
		508	508	3.90	1.08	5.79	6.42	3.06	5.13	1.97	1.18		.67	643.50				
127	5	35	35	120	28	180	184	92	152,4	50	30	5	17	365,0	M16x55	5/8-11 UNC x 2-1/4	BFX-311-G-W1	
		508	508	4.72	1.10	7.09	7.24	3.62	6.00	1.97	1.18		.67	803.00				

Materials / Ordering Options / Examples

- * SAE Single-Part Flange (without O-ring) made of Steel S355J0 or equivalent, blank (oiled) **BFX-...-G-W1**
- * SAE Single-Part Flange (without O-ring) made of Stainless Steel V4A - 1.4404 (on request) **BFX-...-G-W5**

* Size of connection thread deviating from the standard (e.g. 1-1/4 BSPP) **BFX-...-G20-W1**

- * Kit including Metric bolts 8.8, spring rings, O-ring made of NBR (Buna-N®) **BFX-...-G-W46-K**
- * Kit including Metric bolts 8.8, spring rings, O-ring made of FKM/FPM (Viton®) **BFX-...-G-V-W46-K**
- * Kit including Metric bolts 10.9, spring rings, O-ring made of NBR (Buna-N®) **BFX-...-G-MH-W1-K**
- * Kit including UNC bolts (Grade 8), spring rings, O-ring made of NBR (Buna-N®) **BFX-...-G-U-W1-K**

¹ The maximum working pressure PN (bar/PSI) applies only to the flange itself and depends on the bolts used (Grade 8.8 / 10.9). The actual maximum working pressure depends on the thickness and the quality of the tube used.

³ Alternative options shown in brackets are available on request.

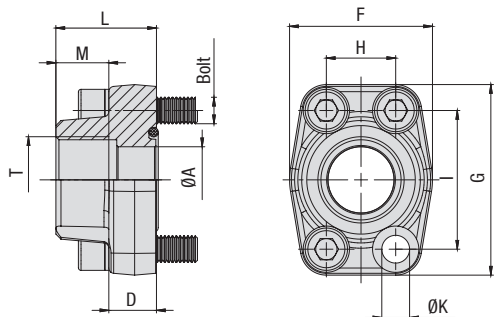

**SAE Single-Part Flange with Female BSPP Thread
Type BFX-G • 6000 PSI Series**

6000 PSI High Pressure Series (based on ISO 6162-2:2002)

Nominal Size	DN (in)	PN ¹ (bar/PSI)	Dimensions (mm/in)										T (BSPP)	ØK	Weight for Bolts (kg/lbs) ca.		Metric	UNC	Ordering Codes
			8.8	10.9 (MH)	ØA	D	F	G	H	I	L	M			per 100	UNC			
13	1/2	350	420	13	16,5	47	57	18,2	40,5	36	15	1/2	8,7	27,2	M8x30	5/16-18 UNC x 1-1/4	BFX-601-G-W1		
		5075	6090	.51	.65	1.85	2.24	.72	1.59	1.42	.59		.34	59.84					
13	1/2	350	420	13	16,5	47	57	18,2	40,5	36	20	3/8 (06)	8,7	29,3	M8x30	5/16-18 UNC x 1-1/4	BFX-601-G06-W1		
		5075	6090	.51	.65	1.85	2.24	.72	1.59	1.42	.79		.34	64.46					
19	3/4	350	420	19	19,5	54	72	23,8	50,8	36	18	3/4	10,5	54,3	M10x35	3/8-16 UNC x 1-1/2	BFX-602-G-W1		
		5075	6090	.75	.77	2.13	2.83	.94	2.00	1.42	.71		.41	119.46					
19	3/4	350	420	14	19,5	54	72	23,8	50,8	36	15	1/2 (08)	10,5	55,7	M10x35	3/8-16 UNC x 1-1/2	BFX-602-G08-W1		
		5075	6090	.55	.77	2.13	2.83	.94	2.00	1.42	.59		.41	122.54					
25	1	350	420	25	24,5	68	82	27,8	57,2	44	20	1	13	83,7	M12x45	7/16-14 UNC x 1-3/4	BFX-603-G-W1 ²		
		5075	6090	.98	.96	2.68	3.23	1.09	2.25	1.73	.79		.51	184.14					
25	1	350	420	19	24,5	68	82	27,8	57,2	44	18	3/4 (12)	13	80,0	M12x45	7/16-14 UNC x 1-3/4	BFX-603-G12-W1 ²		
		5075	6090	.75	.96	2.68	3.23	1.09	2.25	1.73	.71		.51	176.00					
32	1-1/4	350	420	31	27,5	79	95	31,6	66,6	44	22	1-1/4	13,5	119,3	M12x45	1/2-13 UNC x 1-3/4	BFX-604-G-W1		
		5075	6090	1.22	1.08	3.11	3.74	1.24	2.62	1.73	.87		.53	262.46					
32	1-1/4	350	420	31	27,5	79	95	31,6	66,6	44	22	1-1/4	15	112,6	M14x45	/	BFX-604-G-M14-W1		
		5075	6090	1.22	1.08	3.11	3.74	1.24	2.62	1.73	.87		.59	247.72					
32	1-1/4	350	420	25	27,5	79	95	31,6	66,6	44	20	1	13,5	122,0	M12x45	1/2-13 UNC x 1-3/4	BFX-604-G16-W1		
		5075	6090	.98	1.08	3.11	3.74	1.24	2.62	1.73	.79		.53	268.40					
32	1-1/4	350	420	25	27,5	79	95	31,6	66,6	44	20	1	15	118,4	M14x45	/	BFX-604-G16-M14-W1		
		5075	6090	.98	1.08	3.11	3.74	1.24	2.62	1.73	.79		.59	260.48					
38	1-1/2	350	420	38	31	88	108	36,5	79,3	51	24	1-1/2	17	183,3	M16x55	5/8-11 UNC x 2-1/4	BFX-605-G-W1		
		5075	6090	1.50	1.22	3.46	4.25	1.44	3.12	2.01	.94		.67	403.26					
38	1-1/2	350	420	31	31	88	108	36,5	79,3	51	22	1-1/4 (20)	17	196,0	M16x55	5/8-11 UNC x 2-1/4	BFX-605-G20-W1		
		5075	6090	1.22	1.22	3.46	4.25	1.44	3.12	2.01	.87		.67	431.20					
51	2	350	420	50	37	118	137	44,5	96,8	65	33	2	21	327,9	M20x70	3/4-10 UNC x 2-3/4	BFX-606-G32-W1		
		5075	6090	1.97	1.46	4.65	5.39	1.75	3.81	2.56	1.30		.83	721.38					
64	2-1/2	350	420	63	123,8	180	58,7	152	80	45	32	2-1/2	26	678,1	M24x80	/	BFX-607-G-W1		
		5075	6090	2.48	4.87	7.09	2.31	5.98	3.15	1.77	1.26		1.02	1491.82					

¹ The maximum working pressure PN (bar/PSI) applies only to the flange itself and depends on the bolts used (Grade 8.8 / 10.9). The actual maximum working pressure depends on the thickness and the quality of the tube used.

² For UNC threaded bolts, use hexagon head bolts only. Please note that these do not belong to our product range.

Materials / Ordering Options / Examples

- * SAE Single-Part Flange (without O-ring) made of Steel S355J0 or equivalent, blank (oiled) BFX-...-G-W1
- * SAE Single-Part Flange (without O-ring) made of Stainless Steel V4A - 1.4404 (on request) BFX-...-G-W5
- * Size of connection thread deviating from the standard (e.g. 1-1/4 BSPP) BFX-...-G20-W1
- * Kit including Metric bolts 8.8, spring rings, O-ring made of NBR (Buna-N®) BFX-...-G-W46-K
- * Kit including Metric bolts 8.8, spring rings, O-ring made of FKM/FPM (Viton®) BFX-...-G-V-W46-K
- * Kit including Metric bolts 10.9, spring rings, O-ring made of NBR (Buna-N®) BFX-...-G-MH-W1-K
- * Kit including UNC bolts (Grade 8), spring rings, O-ring made of NBR (Buna-N®) BFX-...-G-U-W1-K



**SAE Single-Part Counterflange with Female BSPP Thread
Type BAS-G - 3000 PSI Series**

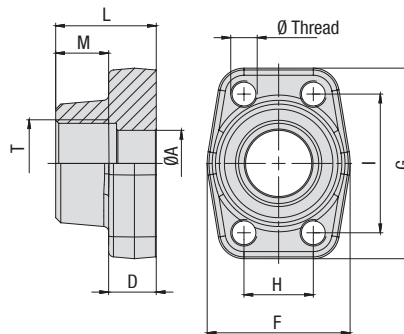

3000 PSI Standard Pressure Series (based on ISO 6162-1:2002)

Nominal Size	DN	(in)	PN ¹ (bar/PSI)		Dimensions (mm/in)								T (BSPP)	Weight (kg/lbs) ca. per 100	Ø Thread		Ordering Codes
			8.8	10.9 (MH)	ØA	D	F	G	H	I	L	M			Metric ³	UNC	
13	1/2		350	350	13	16	47	57	17,5	38,1	36	15	1/2	29,0	M8	5/16-18 UNC	BAS-301-G-W1
			5075	5075	.51	.63	1.85	2.24	.69	1.50	1.42	.59		63.80			
13	1/2		350	350	13	16	47	57	17,5	38,1	36	20	3/8 (06)	30,8	M8	5/16-18 UNC	BAS-301-G06-W1
			5075	5075	.51	.63	1.85	2.24	.69	1.50	1.42	.79		67.76			
19	3/4		350	350	19	18	50	67	22,3	47,6	36	18	3/4	41,4	M10	3/8-16 UNC	BAS-302-G-W1
			5075	5075	.75	.71	1.97	2.64	.88	1.87	1.42	.71		91.08			
19	3/4		350	350	13	18	50	67	22,3	47,6	36	15	1/2 (08)	43,4	M10	3/8-16 UNC	BAS-302-G08-W1
			5075	5075	.51	.71	1.97	2.64	.88	1.87	1.42	.59		95.48			
25	1		250	315	25	18	54	72	26,2	52,4	38	20	1	47,0	M10	3/8-16 UNC	BAS-303-G-W1
			3625	4568	.98	.71	2.13	2.83	1.03	2.06	1.50	.79		103.40			
25	1		250	315	19	18	54	72	26,2	52,4	38	18	3/4 (12)	56,7	M10	3/8-16 UNC	BAS-303-G12-W1
			3625	4568	.75	.71	2.13	2.83	1.03	2.06	1.50	.71		124.74			
32	1-1/4		200	250	31	21	68	82	30,2	58,7	41	22	1-1/4	69,5	M10 (M12)	7/16-14 UNC	BAS-304-G-W1
			2900	3625	1.22	.83	2.68	3.23	1.19	2.31	1.61	.87		152.90			
32	1-1/4		200	250	25	21	68	82	30,2	58,7	41	20	1 (16)	84,4	M10 (M12)	7/16-14 UNC	BAS-304-G16-W1
			2900	3625	.98	.83	2.68	3.23	1.19	2.31	1.61	.79		185.68			
38	1-1/2		200	200	38	25	79	96	35,7	69,9	44	24	1-1/2	114,3	M12 (M14)	1/2-13 UNC	BAS-305-G-W1
			2900	2900	1.50	.98	3.11	3.78	1.41	2.75	1.73	.94		251.46			
38	1-1/2		200	200	31	25	79	96	35,7	69,9	44	22	1-1/4 (20)	124,6	M12 (M14)	1/2-13 UNC	BAS-305-G20-W1
			2900	2900	1.22	.98	3.11	3.78	1.41	2.75	1.73	.87		274.12			
51	2		160	200	50	25,5	88	102	42,9	77,8	45	26	2	125,7	M12 (M14)	1/2-13 UNC	BAS-306-G-W1
			2320	2900	1.97	1.00	3.46	4.02	1.69	3.06	1.77	1.02		276.54			
51	2		160	200	38	25,5	88	102	42,9	77,8	45	24	1-1/2 (24)	158,0	M12 (M14)	1/2-13 UNC	BAS-306-G24-W1
			2320	2900	1.50	1.00	3.46	4.02	1.69	3.06	1.77	.94		347.60			
64	2-1/2		100	160	63	26	101	115	50,8	88,9	50	30	2-1/2	158,1	M12 (M14)	1/2-13 UNC	BAS-307-G-W1
			1450	2320	2.48	1.02	3.98	4.53	2.00	3.50	1.97	1.18		347.82			
64	2-1/2		100	160	50	26	101	115	50,8	88,9	50	26	2 (32)	209,5	M12 (M14)	1/2-13 UNC	BAS-307-G32-W1
			1450	2320	1.97	1.02	3.98	4.53	2.00	3.50	1.97	1.02		460.90			
76	3		100	160	73	27,5	127	137	61,9	106,4	50	30	3	229,4	M16	5/8-11 UNC	BAS-308-G-W1
			1450	2320	2.87	1.08	5.00	5.39	2.44	4.19	1.97	1.18		504.68			
76	3		100	160	63	27,5	127	137	61,9	106,4	50	30	2-1/2 (40)	273,4	M16	5/8-11 UNC	BAS-308-G40-W1
			1450	2320	2.48	1.08	5.00	5.39	2.44	4.19	1.97	1.18		601.48			
89	3-1/2		35	35	89	27,5	138	155	69,8	120,7	50	30	3-1/2	253,0	M16	5/8-11 UNC	BAS-309-G-W1
			508	508	3.50	1.08	5.43	6.10	2.75	4.75	1.97	1.18		556.60			
102	4		35	35	99	27,5	147	163	77,8	130,2	50	30	4	302,5	M16	5/8-11 UNC	BAS-310-G-W1
			508	508	3.90	1.08	5.79	6.42	3.06	5.13	1.97	1.18		665.50			
127	5		35	35	120	28	180	184	92	152,4	50	30	5	379,2	M16	5/8-11 UNC	BAS-311-G-W1
			508	508	4.72	1.10	7.09	7.24	3.62	6.00	1.97	1.18		834.24			

Materials / Ordering Options / Examples

- * SAE Single-Part Counterflange made of Steel S355J0 or equivalent, blank (oiled) with Metric tapped holes **BAS-...-G-W1**
- * SAE Single-Part Counterflange made of Stainless Steel V4A - 1.4404 (on request) with Metric tapped holes **BAS-...-G-W5**
- * SAE Single-Part Counterflange made of Steel S355J0 or equivalent, blank (oiled) with size of Metric tapped holes deviating from the standard (e.g. M14) **BAS-...-G-M14-W1**
- * SAE Single-Part Counterflange made of Steel S355J0 or equivalent, blank (oiled) with UNC tapped holes **BAS-...-G-U-W1**
- * Size of connection thread deviating from the standard (e.g. 1-1/4 BSPP) **BAS-...-G20-W1**

¹ The maximum working pressure PN (bar/PSI) applies only to the flange itself and depends on the bolts used (Grade 8.8 / 10.9). The actual maximum working pressure depends on the thickness and the quality of the tube used.

³ Alternative options shown in brackets are available on request.



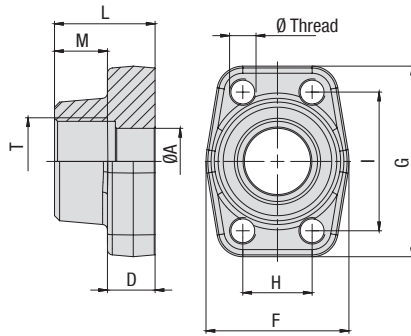

SAE Single-Part Counterflange with Female BSPP Thread Type BAS-G • 6000 PSI Series



6000 PSI High Pressure Series (based on ISO 6162-2:2002)

Nominal Size		PN ¹ (bar/PSI)		Dimensions (mm/in)										Weight (kg/lbs) ca.		Ø Thread		Ordering Codes
DN	(in)	8.8	10.9 (MH)	ØA	D	F	G	H	I	L	M	T (BSPP)	per 100	Metric	UNC			
13	1/2	350	420	13	16,5	47	57	18,2	40,5	36	15	1/2	28,9	M8	5/16-18 UNC	BAS-601-G-W1		
		5075	6090	.51	.65	1.85	2.24	.72	1.59	1.42	.59		63.58					
13	1/2	350	420	13	16,5	47	57	18,2	40,5	36	20	3/8 (06)	31,3	M8	5/16-18 UNC	BAS-601-G06-W1		
		5075	6090	.51	.65	1.85	2.24	.72	1.59	1.42	.79		68.86					
19	3/4	350	420	19	19,5	54	72	23,8	50,8	36	18	3/4	52,6	M10	3/8-16 UNC	BAS-602-G-W1		
		5075	6090	.75	.77	2.13	2.83	.94	2.00	1.42	.71		115.72					
19	3/4	350	420	14	19,5	54	72	23,8	50,8	36	15	1/2 (08)	58,6	M10	3/8-16 UNC	BAS-602-G08-W1		
		5075	6090	.55	.77	2.13	2.83	.94	2.00	1.42	.59		128.92					
25	1	350	420	25	24,5	68	82	27,8	57,2	44	20	1	77,9	M12	7/16-14 UNC	BAS-603-G-W1		
		5075	6090	.98	.96	2.68	3.23	1.09	2.25	1.73	.79		171.38					
25	1	350	420	19	24,5	68	82	27,8	57,2	44	18	3/4 (12)	88,3	M12	7/16-14 UNC	BAS-603-G12-W1		
		5075	6090	.75	.96	2.68	3.23	1.09	2.25	1.73	.71		194.26					
32	1-1/4	350	420	31	27,5	79	95	31,6	66,6	44	22	1-1/4	123,8	M12	1/2-13 UNC	BAS-604-G-W1		
		5075	6090	1.22	1.08	3.11	3.74	1.24	2.62	1.73	.87		272.36					
32	1-1/4	350	420	31	27,5	79	95	31,6	66,6	44	22	1-1/4 (20)	119,9	M14		BAS-604-G-M14-W1		
		5075	6090	1.22	1.08	3.11	3.74	1.24	2.62	1.73	.87		263.78					
32	1-1/4	350	420	25	27,5	79	95	31,6	66,6	44	20	1 (16)	123,8	M12	1/2-13 UNC	BAS-604-G16-W1		
		5075	6090	.98	1.08	3.11	3.74	1.24	2.62	1.73	.79		272.36					
32	1-1/4	350	420	25	27,5	79	95	31,6	66,6	44	20	1 (16)	122,4	M14		BAS-604-G16-M14-W1		
		5075	6090	.98	1.08	3.11	3.74	1.24	2.62	1.73	.79		269.28					
38	1-1/2	350	420	38	31	88	108	36,5	79,3	51	24	1-1/2	186,9	M16	5/8-11 UNC	BAS-605-G-W1		
		5075	6090	1.50	1.22	3.46	4.25	1.44	3.12	2.01	.94		411.18					
38	1-1/2	350	420	31	31	88	108	36,5	79,3	51	22	1-1/4 (20)	203,4	M16	5/8-11 UNC	BAS-605-G20-W1		
		5075	6090	1.22	1.22	3.46	4.25	1.44	3.12	2.01	.87		447.48					
51	2	350	420	50	37	118	137	44,5	96,8	58	33	2	341,5	M20	3/4-10 UNC	BAS-606-G-W1		
		5075	6090	1.97	1.46	4.65	5.39	1.75	3.81	2.28	1.30		751.30					
64	2-1/2	350	420	63	123,8	180	58,7	152	80	45	32	2-1/2	696,0	M24		BAS-607-G-W1		
		5075	6090	2.48	4.87	7.09	2.31	5.98	3.15	1.77	1.26		1531.20					

¹ The maximum working pressure PN (bar/PSI) applies only to the flange itself and depends on the bolts used (Grade 8.8 / 10.9). The actual maximum working pressure depends on the thickness and the quality of the tube used.

Materials / Ordering Options / Examples

- * SAE Single-Part Counterflange made of Steel S355J0 or equivalent, blank (oiled) with Metric tapped holes **BAS-...-G-W1**
- * SAE Single-Part Counterflange made of Stainless Steel V4A – 1.4404 (on request) with Metric tapped holes **BAS-...-G-W5**
- * SAE Single-Part Counterflange made of Steel S355J0 or equivalent, blank (oiled) with size of Metric tapped holes deviating from the standard (e.g. M14) **BAS-...-G-M14-W1**
- * SAE Single-Part Counterflange made of Steel S355J0 or equivalent, blank (oiled) with UNC tapped holes **BAS-...-G-U-W1**
- * Size of connection thread deviating from the standard (e.g. 1-1/4 BSPP) **BAS-...-G20-W1**



SAE Single-Part Flange with Female NPT Thread
Type BFX-N • 3000 PSI Series

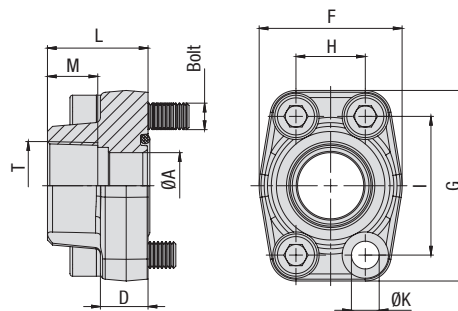

3000 PSI Standard Pressure Series (based on ISO 6162-1:2002)

Nominal Size	DN	(in)	PN ¹ (bar/PSI)		Dimensions (mm/in)										T (NPT)	ØK ³	Weight (kg/lbs) ca.		for Bolts		Ordering Codes
			8.8	10.9 (MH)	ØA	D	F	G	H	I	L	M	per 100	Metric ³			UNC				
13	1/2		350	350	13	16	47	57	17,5	38,1	36	15	1/2	8,7	27,6	M8x30	5/16-18 UNC x 1-1/4	BFX-301-N-W1			
			5075	5075	.51	.63	1.85	2.24	.69	1.50	1.42	.59	.34	60.72							
13	1/2		350	350	13	16	47	57	17,5	38,1	36	20	3/8 (06)	8,7	30,7	M8x30	5/16-18 UNC x 1-1/4	BFX-301-N06-W1			
			5075	5075	.51	.63	1.85	2.24	.69	1.50	1.42	.79		.34	67.54						
19	3/4		350	350	19	18	50	67	22,3	47,6	36	18	3/4	10,5	38,8	M10x35	3/8-16 UNC x 1-1/2	BFX-302-N-W1			
			5075	5075	.75	.71	1.97	2.64	.88	1.87	1.42	.71		.41	85.36						
19	3/4		350	350	13	18	50	67	22,3	47,6	36	15	1/2 (08)	10,5	40,0	M10x35	3/8-16 UNC x 1-1/2	BFX-302-N08-W1			
			5075	5075	.51	.71	1.97	2.64	.88	1.87	1.42	.59		.41	88.00						
25	1		250	315	25	18	54	72	26,2	52,4	38	20	1	10,5	46,0	M10x35	3/8-16 UNC x 1-1/2	BFX-303-N-W1			
			3625	4568	.98	.71	2.13	2.83	1.03	2.06	1.50	.79		.41	101.20						
25	1		250	315	19	18	54	72	26,2	52,4	38	18	3/4 (12)	10,5	53,3	M10x35	3/8-16 UNC x 1-1/2	BFX-303-N12-W1			
			3625	4568	.75	.71	2.13	2.83	1.03	2.06	1.50	.71		.41	117.26						
32	1-1/4		200	250	31	21	68	82	30,2	58,7	41	22	1-1/4	11,5 (13,5)	69,5	M10x40 (M12x40)	7/16-14 UNC x 1-1/2	BFX-304-N-W1			
			2900	3625	1.22	.83	2.68	3.23	1.19	2.31	1.61	.87		.4 (53)	152.90						
32	1-1/4		200	250	25	21	68	82	30,2	58,7	41	20	1 (16)	11,5 (13,5)	84,0	M10x40 (M12x40)	7/16-14 UNC x 1-1/2	BFX-304-N16-W1			
			2900	3625	.98	.83	2.68	3.23	1.19	2.31	1.61	.79		.45 (53)	184.80						
38	1-1/2		200	200	38	25	79	96	35,7	69,9	44	24	1-1/2	13,5 (14,5)	106,6	M12x45 (M14x45)	1/2-13 UNC x 1-3/4	BFX-305-N-W1			
			2900	2900	1.50	.98	3.11	3.78	1.41	2.75	1.73	.94		.53 (57)	234.52						
38	1-1/2		200	200	31	25	79	96	35,7	69,9	44	22	1-1/4 (20)	13,5 (14,5)	125,8	M12x45 (M14x45)	1/2-13 UNC x 1-3/4	BFX-305-N20-W1			
			2900	2900	1.22	.98	3.11	3.78	1.41	2.75	1.73	.87		.53 (57)	276.76						
51	2		160	200	50	25,5	88	102	42,9	77,8	45	26	2	13,5 (14,5)	122,9	M12x45 (M14x45)	1/2-13 UNC x 1-3/4	BFX-306-N-W1			
			2320	2900	1.97	1.00	3.46	4.02	1.69	3.06	1.77	1.02		.53 (57)	270.38						
51	2		160	200	38	25,5	88	102	42,9	77,8	45	24	1-1/2 (24)	13,5 (14,5)	150,0	M12x45 (M14x45)	1/2-13 UNC x 1-3/4	BFX-306-N24-W1			
			2320	2900	1.50	1.00	3.46	4.02	1.69	3.06	1.77	.94		.53 (57)	330.00						
64	2-1/2		100	160	63	26	101	115	50,8	88,9	50	30	2-1/2	13,5 (14,5)	153,9	M12x45 (M14x45)	1/2-13 UNC x 1-3/4	BFX-307-N-W1			
			1450	2320	2.48	1.02	3.98	4.53	2.00	3.50	1.97	1.18		.53 (57)	338.58						
64	2-1/2		100	160	50	26	101	115	50,8	88,9	50	26	2 (32)	13,5 (14,5)	202,9	M12x45 (M14x45)	1/2-13 UNC x 1-3/4	BFX-307-N32-W1			
			1450	2320	1.97	1.02	3.98	4.53	2.00	3.50	1.97	1.02		.53 (57)	446.38						
76	3		100	160	73	27,5	127	137	61,9	106,4	50	30	3	17	225,7	M16x50	5/8-11 UNC x 2	BFX-308-N-W1			
			1450	2320	2.87	1.08	5.00	5.39	2.44	4.19	1.97	1.18		.67	496.54						
76	3		100	160	63	27,5	127	137	61,9	106,4	50	30	2-1/2 (40)	17	269,7	M16x50	5/8-11 UNC x 2	BFX-308-N40-W1			
			1450	2320	2.48	1.08	5.00	5.39	2.44	4.19	1.97	1.18		.67	593.34						
89	3-1/2		35	35	89	27,5	138	155	69,8	120,7	50	30	3-1/2	17	255,0	M16x50	5/8-11 UNC x 2	BFX-309-N-W1			
			508	508	3.50	1.08	5.43	6.10	2.75	4.75	1.97	1.18		.67	561.00						
102	4		35	35	99	27,5	147	163	77,8	130,2	50	30	4	17	286,8	M16x50	5/8-11 UNC x 2	BFX-310-N-W1			
			508	508	3.90	1.08	5.79	6.42	3.06	5.13	1.97	1.18		.67	630.96						
127	5		35	35	120	28	180	184	92	152,4	50	30	5	17	365,2	M16x55	5/8-11 UNC x 2-1/4	BFX-311-N-W1			
			508	508	4.72	1.10	7.09	7.24	3.62	6.00	1.97	1.18		.67	803.44						

Materials / Ordering Options / Examples

- * SAE Single-Part Flange (without O-ring) made of Steel S355J0 or equivalent, blank (oiled)
- * SAE Single-Part Flange (without O-ring) made of Stainless Steel V4A – 1.4404 (on request)

BFX-...-N-W1
BFX-...-N-W5

- * Size of connection thread deviating from the standard (e.g. 1-1/4 NPT)

BFX-...-N20-W1

- * Kit including Metric bolts 8.8, spring rings, O-ring made of NBR (Buna-N®)
- * Kit including Metric bolts 8.8, spring rings, O-ring made of FKM/FPM (Viton®)
- * Kit including Metric bolts 10.9, spring rings, O-ring made of NBR (Buna-N®)
- * Kit including UNC bolts (Grade 8), spring rings, O-ring made of NBR (Buna-N®)

BFX-...-N-W46-K
BFX-...-N-V-W46-K
BFX-...-N-MH-W1-K
BFX-...-N-U-W1-K

¹ The maximum working pressure PN (bar/PSI) applies only to the flange itself and depends on the bolts used (Grade 8.8 / 10.9). The actual maximum working pressure depends on the thickness and the quality of the tube used.

³ Alternative options shown in brackets are available on request.

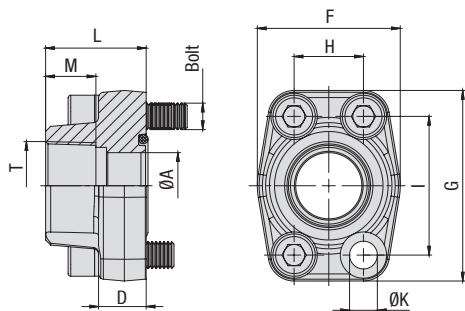

 SAE Single-Part Flange with Female NPT Thread
 Type BFX-N • 6000 PSI Series

6000 PSI High Pressure Series (based on ISO 6162-2:2002)

Nominal Size	PN ¹ (bar/PSI)	Dimensions (mm/in)											Weight (^{kg} /lb) ca.		for Bolts		Ordering Codes
		DN	(in)	8.8	10.9 (MH)	ØA	D	F	G	H	I	L	M	T (NPT)	ØK	per 100	
13	1/2	350	420	13	16,5	47	57	18,2	40,5	36	15	1/2	8,7	27,6	M8x30	5/16-18 UNC x 1-1/4	BFX-601-N-W1
		5075	6090	.51	.65	1.85	2.24	.72	1.59	1.42	.59		.34	60.72			
13	1/2	350	420	13	16,5	47	57	18,2	40,5	36	20	3/8 (06)	8,7	31,5	M8x30	5/16-18 UNC x 1-1/4	BFX-601-N06-W1
		5075	6090	.51	.65	1.85	2.24	.72	1.59	1.42	.79		.34	69.30			
19	3/4	350	420	19	19,5	54	72	23,8	50,8	36	18	3/4	10,5	54,9	M10x35	3/8-16 UNC x 1-1/2	BFX-602-N-W1
		5075	6090	.75	.77	2.13	2.83	.94	2.00	1.42	.71		.41	120.78			
19	3/4	350	420	14	19,5	54	72	23,8	50,8	36	15	1/2 (08)	10,5	56,3	M10x35	3/8-16 UNC x 1-1/2	BFX-602-N08-W1
		5075	6090	.55	.77	2.13	2.83	.94	2.00	1.42	.59		.41	123.86			
25	1	350	420	25	24,5	68	82	27,8	57,2	44	20	1	13	79,0	M12x45	7/16-14 UNC x 1-3/4	BFX-603-N-W1 ²
		5075	6090	.98	.96	2.68	3.23	1.09	2.25	1.73	.79		.51	173.80			
25	1	350	420	19	24,5	68	82	27,8	57,2	44	18	3/4 (12)	13	92,9	M12x45	7/16-14 UNC x 1-3/4	BFX-603-N12-W1 ²
		5075	6090	.75	.96	2.68	3.23	1.09	2.25	1.73	.71		.51	204.38			
32	1-1/4	350	420	31	27,5	79	95	31,6	66,6	44	22	1-1/4	13,5	119,0	M12x45	1/2-13 UNC x 1-3/4	BFX-604-N-W1
		5075	6090	1.22	1.08	3.11	3.74	1.24	2.62	1.73	.87		.53	261.80			
32	1-1/4	350	420	31	27,5	79	95	31,6	66,6	44	22	1-1/4 (20)	15	114,6	M14x45	/	BFX-604-N20-M14-W1
		5075	6090	1.22	1.08	3.11	3.74	1.24	2.62	1.73	.87		.59	252.12			
32	1-1/4	350	420	25	27,5	79	95	31,6	66,6	44	20	1	13,5	120,3	M12x45	1/2-13 UNC x 1-3/4	BFX-604-N16-W1
		5075	6090	.98	1.08	3.11	3.74	1.24	2.62	1.73	.79		.53	264.66			
32	1-1/4	350	420	25	27,5	79	95	31,6	66,6	44	20	1 (16)	15	127,7	M14x45	/	BFX-604-N16-M14-W1
		5075	6090	.98	1.08	3.11	3.74	1.24	2.62	1.73	.79		.59	280.94			
38	1-1/2	350	420	38	31	88	108	36,5	79,3	51	24	1-1/2	17	190,6	M16x55	5/8-11 UNC x 2-1/4	BFX-605-N-W1
		5075	6090	1.50	1.22	3.46	4.25	1.44	3.12	2.01	.94		.67	419.32			
38	1-1/2	350	420	31	31	88	108	36,5	79,3	51	22	1-1/4 (20)	17	185,4	M16x55	5/8-11 UNC x 2-1/4	BFX-605-N20-W1
		5075	6090	1.22	1.22	3.46	4.25	1.44	3.12	2.01	.87		.67	407.88			
51	2	350	420	50	37	118	137	44,5	96,8	65	33	2	21	330,5	M20x70	3/4-10 UNC x 2-3/4	BFX-606-N-W1
		5075	6090	1.97	1.46	4.65	5.39	1.75	3.81	2.56	1.30		.83	727.10			

¹ The maximum working pressure PN (bar/PSI) applies only to the flange itself and depends on the bolts used (Grade 8.8 / 10.9). The actual maximum working pressure depends on the thickness and the quality of the tube used.

² For UNC threaded bolts, use hexagon head bolts only. Please note that these do not belong to our product range.

Materials / Ordering Options / Examples

- * SAE Single-Part Flange (without O-ring) made of Steel S355J0 or equivalent, blank (oiled) BFX-...-N-W1
- * SAE Single-Part Flange (without O-ring) made of Stainless Steel V4A – 1.4404 (on request) BFX-...-N-W5
- * Size of connection thread deviating from the standard (e.g. 1-1/4 NPT) BFX-...-N20-W1
- * Kit including Metric bolts 8.8, spring rings, O-ring made of NBR (Buna-N®) BFX-...-N-W46-K
- * Kit including Metric bolts 8.8, spring rings, O-ring made of FKM/FPM (Viton®) BFX-...-N-V-W46-K
- * Kit including Metric bolts 10.9, spring rings, O-ring made of NBR (Buna-N®) BFX-...-N-MH-W1-K
- * Kit including UNC bolts (Grade 8), spring rings, O-ring made of NBR (Buna-N®) BFX-...-N-U-W1-K



**SAE Single-Part Counterflange with Female NPT Thread
Type BAS-N - 3000 PSI Series**

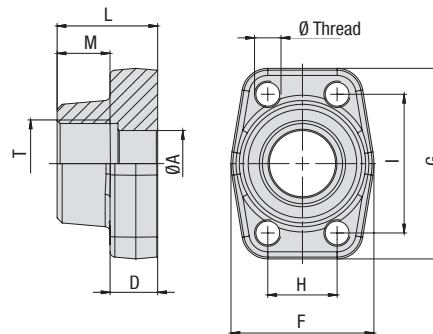

3000 PSI Standard Pressure Series (based on ISO 6162-1:2002)

Nominal Size	DN	(in)	PN ¹ (bar/PSI)		Dimensions (mm/in)								T (NPT)	Weight (^{kg} /lbs) ca. per 100	Ø Thread		Ordering Codes
			8.8	10.9 (MH)	ØA	D	F	G	H	I	L	M			Metric ³	UNC	
13	1/2		350	350	13	16	47	57	17,5	38,1	36	15	1/2	29,0	M8	5/16-18 UNC	BAS-301-N-W1
			5075	5075	.51	.63	1.85	2.24	.69	1.50	1.42	.59		63.80			
13	1/2		350	350	13	16	47	57	17,5	38,1	36	20	3/8 (06)	30,8	M8	5/16-18 UNC	BAS-301-N06-W1
			5075	5075	.51	.63	1.85	2.24	.69	1.50	1.42	.79		67.76			
19	3/4		350	350	19	18	50	67	22,3	47,6	36	18	3/4	40,8	M10	3/8-16 UNC	BAS-302-N-W1
			5075	5075	.75	.71	1.97	2.64	.88	1.87	1.42	.71		89.80			
19	3/4		350	350	13	18	50	67	22,3	47,6	36	15	1/2 (08)	43,6	M10	3/8-16 UNC	BAS-302-N08-W1
			5075	5075	.51	.71	1.97	2.64	.88	1.87	1.42	.59		95.92			
25	1		250	315	25	18	54	72	26,2	52,4	38	20	1	49,5	M10	3/8-16 UNC	BAS-303-N-W1
			3625	4568	.98	.71	2.13	2.83	1.03	2.06	1.50	.79		108.90			
25	1		250	315	19	18	54	72	26,2	52,4	38	18	3/4 (12)	44,6	M10	3/8-16 UNC	BAS-303-N12-W1
			3625	4568	.75	.71	2.13	2.83	1.03	2.06	1.50	.71		98.12			
32	1-1/4		200	250	31	21	68	82	30,2	58,7	41	22	1-1/4	71,2	M10 (M12)	7/16-14 UNC	BAS-304-N-W1
			2900	3625	1.22	.83	2.68	3.23	1.19	2.31	1.61	.87		156.64			
32	1-1/4		200	250	25	21	68	82	30,2	58,7	41	20	1 (16)	85,9	M10 (M12)	7/16-14 UNC	BAS-304-N16-W1
			2900	3625	.98	.83	2.68	3.23	1.19	2.31	1.61	.79		188.98			
38	1-1/2		200	200	38	25	79	96	35,7	69,9	44	24	1-1/2	110,6	M12 (M14)	1/2-13 UNC	BAS-305-N-W1
			2900	2900	1.50	.98	3.11	3.78	1.41	2.75	1.73	.94		243.36			
38	1-1/2		200	200	31	25	79	96	35,7	69,9	44	22	1-1/4 (20)	125,7	M12 (M14)	1/2-13 UNC	BAS-305-N20-W1
			2900	2900	1.22	.98	3.11	3.78	1.41	2.75	1.73	.87		276.54			
51	2		160	200	50	25,5	88	102	42,9	77,8	45	26	2	127,0	M12 (M14)	1/2-13 UNC	BAS-306-N-W1
			2320	2900	1.97	1.00	3.46	4.02	1.69	3.06	1.77	1.02		279.40			
51	2		160	200	38	25,5	88	102	42,9	77,8	45	24	1-1/2 (24)	156,2	M12 (M14)	1/2-13 UNC	BAS-306-N24-W1
			2320	2900	1.50	1.00	3.46	4.02	1.69	3.06	1.77	.94		343.64			
64	2-1/2		100	160	63	26	101	115	50,8	88,9	50	30	2-1/2	176,1	M12 (M14)	1/2-13 UNC	BAS-307-N-W1
			1450	2320	2.48	1.02	3.98	4.53	2.00	3.50	1.97	1.18		387.42			
64	2-1/2		100	160	50	26	101	115	50,8	88,9	50	26	2 (32)	176,1	M12 (M14)	1/2-13 UNC	BAS-307-N32-W1
			1450	2320	1.97	1.02	3.98	4.53	2.00	3.50	1.97	1.02		387.42			
76	3		100	160	73	27,5	127	137	61,9	106,4	50	30	3	233,3	M16	5/8-11 UNC	BAS-308-N-W1
			1450	2320	2.87	1.08	5.00	5.39	2.44	4.19	1.97	1.18		513.26			
76	3		100	160	63	27,5	127	137	61,9	106,4	50	30	2-1/2 (40)	233,3	M16	5/8-11 UNC	BAS-308-N40-W1
			1450	2320	2.48	1.08	5.00	5.39	2.44	4.19	1.97	1.18		513.26			
89	3-1/2		35	35	89	27,5	138	155	69,8	120,7	50	30	3-1/2	253,0	M16	5/8-11 UNC	BAS-309-N-W1
			508	508	3.50	1.08	5.43	6.10	2.75	4.75	1.97	1.18		556.60			
102	4		35	35	99	27,5	147	163	77,8	130,2	50	30	4	287,6	M16	5/8-11 UNC	BAS-310-N-W1
			508	508	3.90	1.08	5.79	6.42	3.06	5.13	1.97	1.18		632.72			
127	5		35	35	120	28	180	184	92	152,4	50	30	5	379,2	M16	5/8-11 UNC	BAS-309-N-W1
			508	508	4.72	1.10	7.09	7.24	3.62	6.00	1.97	1.18		834.24			

Materials / Ordering Options / Examples

- * SAE Single-Part Counterflange made of Steel S355J0 or equivalent, blank (oiled) with Metric tapped holes **BAS-...-N-W1**
- * SAE Single-Part Counterflange made of Stainless Steel V4A - 1.4404 (on request) with Metric tapped holes **BAS-...-N-W5**
- * SAE Single-Part Counterflange made of Steel S355J0 or equivalent, blank (oiled) with size of Metric tapped holes deviating from the standard (e.g. M14) **BAS-...-N-M14-W1**
- * SAE Single-Part Counterflange made of Steel S355J0 or equivalent, blank (oiled) with UNC tapped holes **BAS-...-N-U-W1**
- * Size of connection thread deviating from the standard (e.g. 1-1/4 NPT) **BAS-...-N20-W1**

¹ The maximum working pressure PN (bar/PSI) applies only to the flange itself and depends on the bolts used (Grade 8.8 / 10.9). The actual maximum working pressure depends on the thickness and the quality of the tube used.

³ Alternative options shown in brackets are available on request.



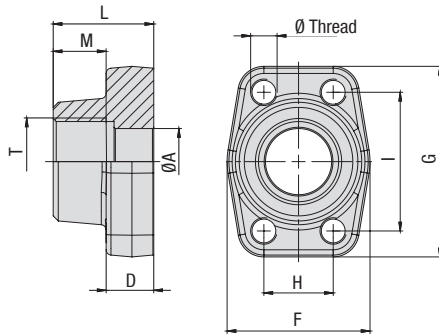

SAE Single-Part Counterflange with Female NPT Thread Type BAS-N • 6000 PSI Series



6000 PSI High Pressure Series (based on ISO 6162-2:2002)

Nominal Size	PN ¹ (bar/PSI)	Dimensions (mm/in)										Weight (kg/lbs) ca.	Ø Thread	Ordering Codes		
		8.8	10.9 (MH)	ØA	D	F	G	H	I	L	M				T (NPT)	per 100
13	1/2	350	420	13	16,5	47	57	18,2	40,5	36	15	1/2	28,7	M8	5/16-18 UNC	BAS-601-N-W1
		5075	6090	.51	.65	1.85	2.24	.72	1.59	1.42	.59		63.14			
13	1/2	350	420	13	16,5	47	57	18,2	40,5	36	20	3/8 (06)	30,7	M8	5/16-18 UNC	BAS-601-N06-W1
		5075	6090	.51	.65	1.85	2.24	.72	1.59	1.42	.79		67.54			
19	3/4	350	420	19	19,5	54	72	23,8	50,8	36	18	3/4	57,0	M10	3/8-16 UNC	BAS-602-N-W1
		5075	6090	.75	.77	2.13	2.83	.94	2.00	1.42	.71		125.40			
19	3/4	350	420	14	19,5	54	72	23,8	50,8	36	15	1/2 (08)	58,9	M10	3/8-16 UNC	BAS-602-N08-W1
		5075	6090	.55	.77	2.13	2.83	.94	2.00	1.42	.59		129.58			
25	1	350	420	25	24,5	68	82	27,8	57,2	44	20	1	83,4	M12	7/16-14 UNC	BAS-603-N-W1
		5075	6090	.98	.96	2.68	3.23	1.09	2.25	1.73	.79		183.48			
25	1	350	420	19	24,5	68	82	27,8	57,2	44	18	3/4 (12)	89,0	M12	7/16-14 UNC	BAS-603-N12-W1
		5075	6090	.75	.96	2.68	3.23	1.09	2.25	1.73	.71		195.80			
32	1-1/4	350	420	31	27,5	79	95	31,6	66,6	44	22	1-1/4	120,3	M12	1/2-13 UNC	BAS-604-N-W1
		5075	6090	1.22	1.08	3.11	3.74	1.24	2.62	1.73	.87		264.66			
32	1-1/4	350	420	31	27,5	79	95	31,6	66,6	44	22	1-1/4 (20)	121,1	M14		BAS-604-N-M14-W1
		5075	6090	1.22	1.08	3.11	3.74	1.24	2.62	1.73	.87		266.42			
32	1-1/4	350	420	25	27,5	79	95	31,6	66,6	44	20	1 (16)	118,0	M12	1/2-13 UNC	BAS-604-N16-W1
		5075	6090	.98	1.08	3.11	3.74	1.24	2.62	1.73	.79		259.60			
32	1-1/4	350	420	25	27,5	79	95	31,6	66,6	44	20	1 (16)	125,6	M14		BAS-604-N16-M14-W1
		5075	6090	.98	1.08	3.11	3.74	1.24	2.62	1.73	.79		276.32			
38	1-1/2	350	420	38	31,0	88	108	36,5	79,3	51	24	1-1/2	200,9	M16	5/8-11 UNC	BAS-605-N-W1
		5075	6090	1.50	1.22	3.46	4.25	1.44	3.12	2.01	.94		441.98			
38	1-1/2	350	420	31	31,0	88	108	36,5	79,3	51	22	1-1/4 (20)	205,5	M16	5/8-11 UNC	BAS-605-N20-W1
		5075	6090	1.22	1.22	3.46	4.25	1.44	3.12	2.01	.87		452.10			
51	2	350	420	50	37,0	118	137	44,5	96,8	58	33	2	346,8	M20	3/4-10 UNC	BAS-606-N-W1
		5075	6090	1.97	1.46	4.65	5.39	1.75	3.81	2.28	1.30		762.96			

¹ The maximum working pressure PN (bar/PSI) applies only to the flange itself and depends on the bolts used (Grade 8.8 / 10.9). The actual maximum working pressure depends on the thickness and the quality of the tube used.

Materials / Ordering Options / Examples

- * SAE Single-Part Counterflange made of Steel S355J0 or equivalent, blank (oiled) with Metric tapped holes **BAS-...-N-W1**
- * SAE Single-Part Counterflange made of Stainless Steel V4A – 1.4404 (on request) with Metric tapped holes **BAS-...-N-W5**
- * SAE Single-Part Counterflange made of Steel S355J0 or equivalent, blank (oiled) with size of Metric tapped holes deviating from the standard (e.g. M14) **BAS-...-N-M14-W1**
- * SAE Single-Part Counterflange made of Steel S355J0 or equivalent, blank (oiled) with UNC tapped holes **BAS-...-N-U-W1**
- * Size of connection thread deviating from the standard (e.g. 1-1/4 NPT) **BAS-...-N20-W1**



**SAE Single-Part Flange with Female UN/UNF Thread
Type BFX-U • 3000 / 6000 PSI Series**

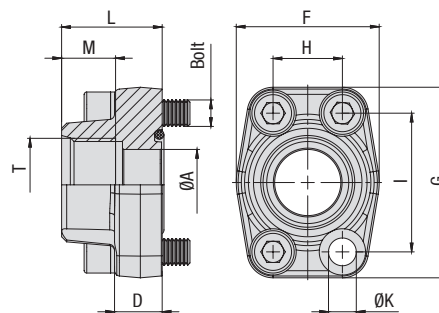

3000 PSI Standard Pressure Series (based on ISO 6162-1:2002)

Nominal Size	DN (in)	PN ¹ (bar/PSI)	Dimensions (mm/in)										T (UN/UNF)	ØK ³	Weight (kg/lbs) ca. per 100	for Bolts		Ordering Codes
			8.8	10.9 (MH)	ØA	D	F	G	H	I	L	M				Metric ³	UNC	
13	1/2	350	350	13	16	47	57	17,5	38,1	36	14,3	3/4-16 (08)	8,7	29,9	M8x30	5/16-18 UNC x 1-1/4	BFX-301-U08-W1	
		5075	5075	.51	.63	1.85	2.24	.69	1.50	1.42	.56		.34	65.78				
19	3/4	350	350	19	18	50	67	22,3	47,6	36	16,7	7/8-14 (10)	10,5	38,1	M10x35	3/8-16 UNC x 1-1/2	BFX-302-U10-W1	
		5075	5075	.75	.71	1.97	2.64	.88	1.87	1.42	.66		.41	83.82				
19	3/4	350	350	19	18	50	67	22,3	47,6	36	16,7	1-1/16-12 (12)	10,5	38,1	M10x35	3/8-16 UNC x 1-1/2	BFX-302-U12-W1	
		5075	5075	.75	.71	1.97	2.64	.88	1.87	1.42	.66		.41	83.82				
25	1	250	315	25	18	54	72	26,2	52,4	38	19	1-1/16-12 (12)	10,5	50,9	M10x35	3/8-16 UNC x 1-1/2	BFX-303-U12-W1	
		3625	4568	.98	.71	2.13	2.83	1.03	2.06	1.50	.75		.41	111.98				
25	1	250	315	25	18	54	72	26,2	52,4	38	19	1-5/16-12 (16)	10,5	47,0	M10x35	3/8-16 UNC x 1-1/2	BFX-303-U16-W1	
		3625	4568	.98	.71	2.13	2.83	1.03	2.06	1.50	.75		.41	103.40				
32	1-1/4	200	250	31	21	68	82	30,2	58,7	41	19	1-5/16-12 (16)	11,5 (13,5)	75,2	M10x40 (M12x40)	7/16-14 UNC x 1-1/2	BFX-304-U16-W1	
		2900	3625	1.22	.83	2.68	3.23	1.19	2.31	1.61	.75		.45 (.53)	165.44				
32	1-1/4	200	250	31	21	68	82	30,2	58,7	41	19	1-5/8-12 (20)	11,5 (13,5)	64,5	M10x40 (M12x40)	7/16-14 UNC x 1-1/2	BFX-304-U20-W1	
		2900	3625	1.22	.83	2.68	3.23	1.19	2.31	1.61	.75		.45 (.53)	141.90				
38	1-1/2	200	200	38	25	79	96	35,7	69,9	44	19	1-5/8-12 (20)	13,5 (14,5)	115,1	M12x45 (M14x45)	1/2-13 UNC x 1-3/4	BFX-305-U20-W1	
		2900	2900	1.50	.98	3.11	3.78	1.41	2.75	1.73	.75		.53 (.57)	253.22				
38	1-1/2	200	200	38	25	79	96	35,7	69,9	44	19	1-7/8-12 (24)	13,5 (14,5)	107,9	M12x45 (M14x45)	1/2-13 UNC x 1-3/4	BFX-305-U24-W1	
		2900	2900	1.50	.98	3.11	3.78	1.41	2.75	1.73	.75		.53 (.57)	237.38				

6000 PSI High Pressure Series (based on ISO 6162-2:2002)

Nominal Size	DN (in)	PN ¹ (bar/PSI)	Dimensions (mm/in)										T (UN/UNF)	ØK ³	Weight (kg/lbs) ca. per 100	for Bolts		Ordering Codes
			8.8	10.9 (MH)	ØA	D	F	G	H	I	L	M				Metric ³	UNC	
13	1/2	350	400	13	16,5	47	57	18,2	40,5	36	14,3	3/4-16 (08)	8,7	29,9	M8x30	5/16-18 UNC x 1-1/4	BFX-601-U08-W1	
		5075	5800	.51	.65	1.85	2.24	.72	1.59	1.42	.56		.34	65.78				
19	3/4	350	400	19	19,5	54	72	23,8	50,8	36	16,7	7/8-14 (10)	10,5	48,3	M10x35	3/8-16 UNC x 1-1/2	BFX-602-U10-W1	
		5075	5800	.75	.77	2.13	2.83	.94	2.00	1.42	.66		.41	106.26				
19	3/4	350	400	19	19,5	54	72	23,8	50,8	36	16,7	1-1/16-12 (12)	10,5	48,3	M10x35	3/8-16 UNC x 1-1/2	BFX-602-U12-W1	
		5075	5800	.75	.77	2.13	2.83	.94	2.00	1.42	.66		.41	106.26				
25	1	350	400	25	24,5	68	82	27,8	57,1	44	19	1-1/16-12 (12)	13	84,0	M12x45	7/16-14 UNC x 1-3/4	BFX-603-U12-W1 ²	
		5075	5800	.98	.96	2.68	3.23	1.09	2.25	1.73	.75		.51	184.80				
25	1	350	400	25	24,5	68	82	27,8	57,1	44	19	1-5/16-12 (16)	13	83,4	M12x45	7/16-14 UNC x 1-3/4	BFX-603-U16-W1 ²	
		5075	5800	.98	.96	2.68	3.23	1.09	2.25	1.73	.75		.51	183.48				
32	1-1/4	350	400	31	27,5	79	95	31,6	66,7	44	19	1-5/16-12 (16)	13,5	125,7	M12x45	1/2-13 UNC x 1-3/4	BFX-604-U16-W1	
		5075	5800	1.22	1.08	3.11	3.74	1.24	2.63	1.73	.75		.53	276.54				
32	1-1/4	350	400	31	27,5	79	95	31,6	66,7	44	19	1-5/16-12 (16)	15	125,7	M14x45	/	BFX-604-U16-M14-W1	
		5075	5800	1.22	1.08	3.11	3.74	1.24	2.63	1.73	.75		.59	276.54				
32	1-1/4	350	400	31	27,5	79	95	31,6	66,7	44	19	1-5/8-12 (20)	13,5	125,7	M12x45	1/2-13 UNC x 1-3/4	BFX-604-U20-W1	
		5075	5800	1.22	1.08	3.11	3.74	1.24	2.63	1.73	.75		.53	276.54				
32	1-1/4	350	400	31	27,5	79	95	31,6	66,7	44	19	1-5/8-12 (20)	15	116,0	M14x45	/	BFX-604-U20-M14-W1	
		5075	5800	1.22	1.08	3.11	3.74	1.24	2.63	1.73	.75		.59	255.20				
38	1-1/2	350	400	38	31	88	108	36,5	79,4	51	19	1-5/8-12 (20)	17	221,5	M16x55	5/8-11 UNC x 2-1/4	BFX-605-U20-W1	
		5075	5800	1.50	1.22	3.46	4.25	1.44	3.13	2.01	.75		.67	487.30				
38	1-1/2	350	400	38	31	88	108	36,5	79,4	51	19	1-7/8-12 (24)	17	169,9	M16x55	5/8-11 UNC x 2-1/4	BFX-605-U24-W1	
		5075	5800	1.50	1.22	3.46	4.25	1.44	3.13	2.01	.75		.67	373.78				

Materials / Ordering Options / Examples

- * SAE Single-Part Flange (without O-ring) made of Steel S355J0 or equivalent, blank (oiled)
- * SAE Single-Part Flange (without O-ring) made of Stainless Steel V4A – 1.4404 (on request)
- * Kit including Metric bolts 8.8, spring rings, O-ring made of NBR (Buna-N®)
- * Kit including Metric bolts 8.8, spring rings, O-ring made of FKM/FPM (Viton®)
- * Kit including Metric bolts 10.9, spring rings, O-ring made of NBR (Buna-N®)
- * Kit including UNC bolts (Grade 8), spring rings, O-ring made of NBR (Buna-N®)

BFX-...-U-W1**
BFX-...-U-W5**

BFX-...-U-W46-K**
BFX-...-U-V-W46-K**
BFX-...-U-MH-W1-K**
BFX-...-U-U-W1-K**

Please always indicate Thread Size.

¹ The maximum working pressure PN (bar/PSI) applies only to the flange itself and depends on the bolts used (Grade 8.8 / 10.9). The actual maximum working pressure depends on the thickness and the quality of the tube used.

² For UNC threaded bolts, use hexagon head bolts only. Please note that these do not belong to our product range.

³ Alternative options shown in brackets are available on request.



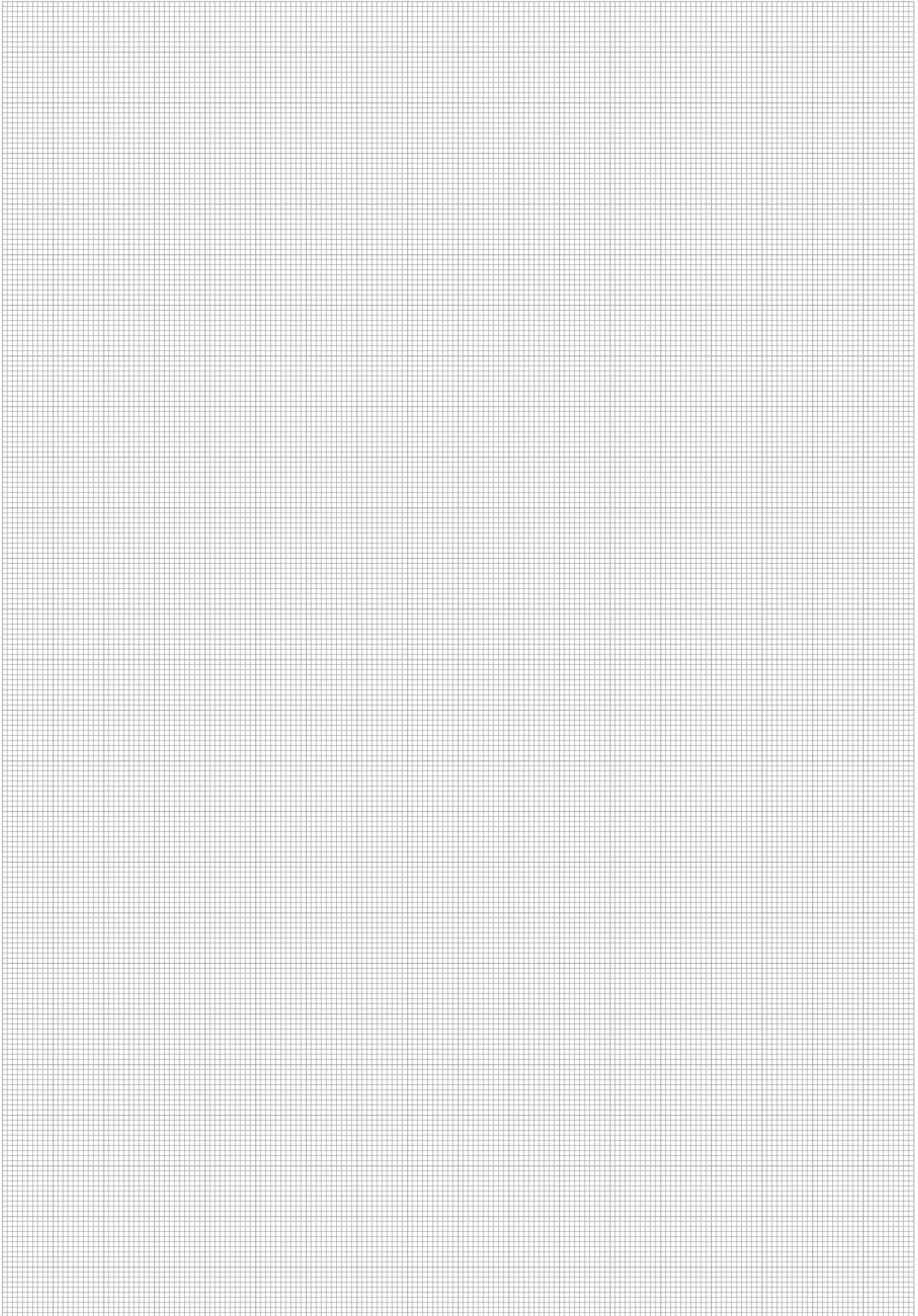

**SAE Single-Part Butt-Weld Flange for High Pressure Tubes (Schedule 80/160/XXS)
Type BFX-ST • 3000 PSI Series**

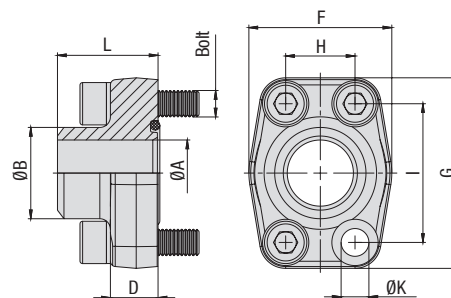

3000 PSI Standard Pressure Series (based on ISO 6162-1:2002)

Nominal Size	DN	(in)	PN ¹ (bar/PSI)	Dimensions (mm/in)									Weight (kg/lbs) ca. per 100	for Bolts		Ordering Codes	
				8.8	10.9 (MH)	ØA	ØB	D	F	G	H	I		L	ØK ³		Metric ³
13	1/2		350	350	13	21,6	16	47	57	17,5	38,1	36	8,7	26,0	M8x30	5/16-18 UNC x 1-1/4	BFX-301-ST-21.6/13-W1
			5075	5075	.51	.85	.63	1.85	2.24	.69	1.50	1.42	.34	57.20			
13	1/2		350	350	13	17,5	16	47	57	17,5	38,1	36	8,7	24,2	M8x30	5/16-18 UNC x 1-1/4	BFX-301-ST-17.5/13-W1
			5075	5075	.51	.69	.63	1.85	2.24	.69	1.50	1.42	.34	53.24			
19	3/4		350	350	19	27,2	18	50	67	22,3	47,6	36	10,5	35,2	M10x35	3/8-16 UNC x 1-1/2	BFX-302-ST-27.2/19-W1
			5075	5075	.75	1.07	.71	1.97	2.64	.88	1.87	1.42	.41	77.44			
25	1		250	315	25	34	18	54	72	26,2	52,4	38	10,5	40,8	M10x35	3/8-16 UNC x 1-1/2	BFX-303-ST-34/25-W1
			3625	4568	.98	1.34	.71	2.13	2.83	1.03	2.06	1.50	.41	89.76			
32	1-1/4		200	250	32	42,8	21	68	82	30,2	58,7	41	11,5 (13,5)	71,3	M10x40 (M12x40)	7/16-14 UNC x 1-1/2	BFX-304-ST-42.8/32-W1
			2900	3625	1.26	1.69	.83	2.68	3.23	1.19	2.31	1.61	.45 (.53)	156.86			
38	1-1/2		200	200	38	48,6	25	79	96	35,7	69,9	44	13,5 (14,5)	97,3	M12x45 (M14x45)	1/2-13 UNC x 1-3/4	BFX-305-ST-48.6/38-W1
			2900	2900	1.50	1.91	.98	3.11	3.78	1.41	2.75	1.73	.53 (.57)	214.06			
51	2		160	200	51	61	25,5	88	102	42,9	77,8	45	13,5 (14,5)	115,1	M12x45 (M14x45)	1/2-13 UNC x 1-3/4	BFX-306-ST-61/51-W1
			2320	2900	2.01	2.40	1.00	3.46	4.02	1.69	3.06	1.77	.53 (.57)	253.22			
64	2-1/2		100	160	63	77	26	101	115	50,8	88,9	50	13,5 (14,5)	153,2	M12x45 (M14x45)	1/2-13 UNC x 1-3/4	BFX-307-ST-77/63-W1
			1450	2320	2.48	3.03	1.02	3.98	4.53	2.00	3.50	1.97	.53 (.57)	337.04			
76	3		100	160	73	92	27,5	127	137	61,9	106,4	50	17	229,0	M16x50	5/8-11 UNC x 2	BFX-308-ST-92/73-W1
			1450	2320	2.87	3.62	1.08	5.00	5.39	2.44	4.19	1.97	.67	503.80			
89	3-1/2		35	35	89	103	27,5	138	155	69,9	120,7	50	17	259,1	M16x50	5/8-11 UNC x 2	BFX-309-ST-103/89-W1
			508	508	3.50	4.06	1.08	5.43	6.10	2.75	4.75	1.97	.67	570.02			
102	4		35	35	99	115,5	27,5	147	163	77,8	130,2	50	17	286,5	M16x50	5/8-11 UNC x 2	BFX-310-ST-115.5/99-W1
			508	508	3.90	4.55	1.08	5.79	6.42	3.06	5.13	1.97	.67	630.30			
127	5		35	35	120	140,2	28	180	184	92	152,4	50	17	398,6	M16x55	5/8-11 UNC x 2-1/4	BFX-311-ST-140.2/120-W1
			508	508	4.72	5.52	1.10	7.09	7.24	3.62	6.00	1.97	.67	876.92			

Materials / Ordering Options / Examples

- * SAE Single-Part Flange (without O-ring) made of Steel S355J0 or equivalent, blank (oiled)
- * SAE Single-Part Flange (without O-ring) made of Stainless Steel V4A – 1.4404 (on request)

BFX-...-ST--**/**-W1**
BFX-...-ST--**/**-W5**

- * Kit including Metric bolts 8.8, spring rings, O-ring made of NBR (Buna-N®)
- * Kit including Metric bolts 8.8, spring rings, O-ring made of FKM/FPM (Viton®)
- * Kit including Metric bolts 10.9, spring rings, O-ring made of NBR (Buna-N®)
- * Kit including UNC bolts (Grade 8), spring rings, O-ring made of NBR (Buna-N®)

BFX-...-ST--**/**-W46-K**
BFX-...-ST--**/**-V-W46-K**
BFX-...-ST--**/**-MH-W1-K**
BFX-...-ST--**/**-U-W1-K**

Please always indicate ØB / ØA.

¹ The maximum working pressure PN (bar/PSI) applies only to the flange itself and depends on the bolts used (Grade 8.8 / 10.9). The actual maximum working pressure depends on the thickness and the quality of the tube used.

³ Alternative options shown in brackets are available on request.



SAE Single-Part Butt-Weld Flange for High Pressure Tubes (Schedule 80/160/XXS) Type BFX-ST - 6000 PSI Series

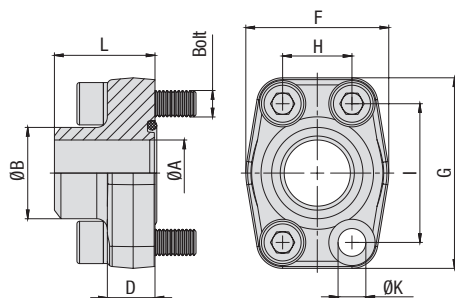

6000 PSI High Pressure Series (based on ISO 6162-2:2002)

Nominal Size	DN (in)	PN ¹ (bar/PSI)		Dimensions (mm/in)										Weight (kg/lbs) ca. per 100		for Bolts		Ordering Codes
		8.8	10.9 (MH)	ØA	ØB	D	F	G	H	I	L	ØK	Metric	UNC				
13	1/2	350	420	13	21,6	16,5	47	57	18,2	40,5	36	8,7	33,3	M8x30	5/16-18 UNC x 1-1/4	BFX-601-ST-21.6/13-W1		
		5075	6090	.51	.85	.65	1.85	2.24	.72	1.59	1.42	.34	73.26					
13	1/2	350	420	13	17,5	16,5	47	57	18,2	40,5	36	8,7	24,2	M8x30	5/16-18 UNC x 1-1/4	BFX-601-ST-17.5/13-W1		
		5075	6090	.51	.69	.65	1.85	2.24	.72	1.59	1.42	.34	53.24					
19	3/4	350	420	19	28	19,5	54	72	23,8	50,8	36	10,5	49,4	M10x35	3/8-16 UNC x 1-1/2	BFX-602-ST-28/19-W1		
		5075	6090	.75	1.10	.77	2.13	2.83	.94	2.00	1.42	.41	108.68					
25	1	350	420	25	34	24,5	68	82	27,8	57,2	41	13	64,1	M12x45	7/16-14 UNC x 1-3/4	BFX-603-ST-34/25-W1 ²		
		5075	6090	.98	1.34	.96	2.68	3.23	1.09	2.25	1.61	.51	141.02					
32	1-1/4	350	420	32	42,8	27,5	79	95	31,8	66,6	44	13,5	101,3	M12x45	1/2-13 UNC x 1-3/4	BFX-604-ST-42.8/32-W1		
		5075	6090	1.26	1.69	1.08	3.11	3.74	1.25	2.62	1.73	.53	222.86					
32	1-1/4	350	420	32	42,8	27,5	79	95	31,8	66,6	44	15	98,1	M14x45		BFX-604-ST-42.8/32-M14-W1		
		5075	6090	1.26	1.69	1.08	3.11	3.74	1.25	2.62	1.73	.59	215.82					
32	1-1/4	350	420	29	42,8	27,5	79	95	31,8	66,6	44	13,5	112,8	M12x45	1/2-13 UNC x 1-3/4	BFX-604-ST-42.8/29-W1 (SCH 160)		
		5075	6090	1.14	1.69	1.08	3.11	3.74	1.25	2.62	1.73	.53	248.16					
32	1-1/4	350	420	29	42,8	27,5	79	95	31,8	66,6	44	15	100,8	M14x45		BFX-604-ST-42.8/29-M14-W1		
		5075	6090	1.14	1.69	1.08	3.11	3.74	1.25	2.62	1.73	.59	221.76					
38	1-1/2	350	420	38	48,6	31	88	108	36,5	79,3	56	17	168,2	M16x55	5/8-11 UNC x 2-1/4	BFX-605-ST-48.6/38-W1		
		5075	6090	1.50	1.91	1.22	3.46	4.25	1.44	3.12	2.20	.67	370.04					
38	1-1/2	350	420	32	48,6	31	88	108	36,5	79,3	56	17	170,9	M16x55	5/8-11 UNC x 2-1/4	BFX-605-ST-48.6/32-W1 (SCH 160)		
		5075	6090	1.26	1.91	1.22	3.46	4.25	1.44	3.12	2.20	.67	375.98					
51	2	350	420	51	61	37	118	137	44,5	96,8	65	21	284,5	M20x70	3/4-10 UNC x 2-3/4	BFX-606-ST-61/51-W1		
		5075	6090	2.01	2.40	1.46	4.65	5.39	1.75	3.81	2.56	.83	625.90					
51	2	350	420	43	61	37	118	137	44,5	96,8	65	21	316,4	M20x70	3/4-10 UNC x 2-3/4	BFX-606-ST-61/43-W1 (SCH 160)		
		5075	6090	1.69	2.40	1.46	4.65	5.39	1.75	3.81	2.56	.83	696.08					
64	2-1/2	350	420	51	76,1	45	150	180	58,7	123,8	80	26	727,7	M24x80		BFX-607-ST-76.1/51-W1		
		5075	6090	2.01	3.00	1.77	5.91	7.09	2.31	4.87	3.15	1.02	1600.94					
64	2-1/2	350	420	60	90	45	150	180	58,7	123,8	80	26	730,0	M24x80		BFX-607-ST-90/60-W1 (SCH XXS)		
		5075	6090	2.36	3.54	1.77	5.91	7.09	2.31	4.87	3.15	1.02	1606.00					
76	3	350	420	90	67,7	152,4	208	71,4	178	90	55	33	1305,0	M30x100		BFX-608-ST-90/67-W1 (SCH 160)		
		5075	6090	3.54	2.67	6.00	8.19	2.81	7.01	3.54	2.17	1.30	2871.00					
76	3	350	420	90	58,4	152,4	208	71,4	178	90	55	33	1305,0	M30x100		BFX-608-ST-90/58-W1 (SCH XXS)		
		5075	6090	3.54	2.30	6.00	8.19	2.81	7.01	3.54	2.17	1.30	2871.00					

¹ The maximum working pressure PN (bar/PSI) applies only to the flange itself and depends on the bolts used (Grade 8.8 / 10.9). The actual maximum working pressure depends on the thickness and the quality of the tube used.

² For UNC threaded bolts, use hexagon head bolts only. Please note that these do not belong to our product range.

Materials / Ordering Options / Examples

- * SAE Single-Part Flange (without O-ring) made of Steel S355J0 or equivalent, blank (oiled) BFX-...-ST-*/**/W1
- * SAE Single-Part Flange (without O-ring) made of Stainless Steel V4A - 1.4404 (on request) BFX-...-ST-*/**/W5

- * Kit including Metric bolts 8.8, spring rings, O-ring made of NBR (Buna-N®) BFX-...-ST-*/**/W46-K
- * Kit including Metric bolts 8.8, spring rings, O-ring made of FKM/FPM (Viton®) BFX-...-ST-*/**/V-W46-K
- * Kit including Metric bolts 10.9, spring rings, O-ring made of NBR (Buna-N®) BFX-...-ST-*/**/MH-W1-K
- * Kit including UNC bolts (Grade 8), spring rings, O-ring made of NBR (Buna-N®) BFX-...-ST-*/**/U-W1-K

Please always indicate ØB / ØA.



SAE Single-Part Butt-Weld Counterflange for High Pressure Tubes (Schedule 80/160/XXS)
Type BAS-ST • 3000 PSI Series

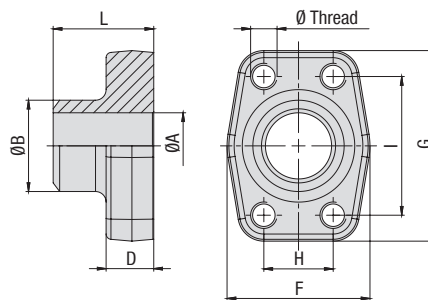

3000 PSI Standard Pressure Series (based on ISO 6162-1:2002)

Nominal Size	DN	(in)	PN ¹ (bar/PSI)		Dimensions (mm/in)								Weight (kg/lbs) ca. per 100	Ø Thread		Ordering Codes
			8.8	10.9 (MH)	ØA	ØB	D	F	G	H	I	L		Metric ³	UNC	
13	1/2		350	350	13	21,6	16	47	57	17,5	38,1	36	26,3	M8	5/16-18 UNC	BAS-301-ST-21.6/13-W1
			5075	5075	.51	.85	.63	1.85	2.24	.69	1.50	1.42	57.86			
13	1/2		350	350	13	17,5	16	47	57	17,5	38,1	36	25,8	M8	5/16-18 UNC	BAS-301-ST-17.5/13-W1
			5075	5075	.51	.69	.63	1.85	2.24	.69	1.50	1.42	56.76			
19	3/4		350	350	19	27,2	18	50	67	22,3	47,6	36	36,6	M10	3/8-16 UNC	BAS-302-ST-27.2/19-W1
			5075	5075	.75	1.07	.71	1.97	2.64	.88	1.87	1.42	80.52			
25	1		250	315	25	34	18	54	72	26,2	52,4	38	43,1	M10 (M12)	7/16-14 UNC	BAS-303-ST-34/25-W1
			3625	4568	.98	1.34	.71	2.13	2.83	1.03	2.06	1.50	94.82			
32	1-1/4		200	250	32	42,8	21	68	82	30,2	58,7	41	67,5	M10 (M12)	7/16-14 UNC	BAS-304-ST-42.8/32-W1
			2900	3625	1.26	1.69	.83	2.68	3.23	1.19	2.31	1.61	148.50			
38	1-1/2		200	200	38	48,6	25	79	96	35,7	69,9	44	103,4	M12 (M14)	1/2-13 UNC	BAS-305-ST-48.6/38-W1
			2900	2900	1.50	1.91	.98	3.11	3.78	1.41	2.75	1.73	227.48			
51	2		160	200	51	61	25,5	88	102	42,9	77,8	45	122,7	M12 (M14)	1/2-13 UNC	BAS-306-ST-61/51-W1
			2320	2900	2.01	2.40	1.00	3.46	4.02	1.69	3.06	1.77	269.94			
64	2-1/2		100	160	63	77	26	101	115	50,8	88,9	50	155,8	M12 (M14)	1/2-13 UNC	BAS-307-ST-77/63-W1
			1450	2320	2.48	3.03	1.02	3.98	4.53	2.00	3.50	1.97	342.76			
76	3		100	160	73	92	27,5	127	137	61,9	106,4	50	236,0	M16	5/8-11 UNC	BAS-308-ST-92/73-W1
			1450	2320	2.87	3.62	1.08	5.00	5.39	2.44	4.19	1.97	519.20			
89	3-1/2		35	35	89	103	27,5	138	155	69,9	120,7	50	267,3	M16	5/8-11 UNC	BAS-309-ST-103/89-W1
			508	508	3.50	4.06	1.08	5.43	6.10	2.75	4.75	1.97	588.06			
102	4		35	35	99	115,5	27,5	147	163	77,8	130,2	50	291,3	M16	5/8-11 UNC	BAS-310-ST-115.5/99-W1
			508	508	3.90	4.55	1.08	5.79	6.42	3.06	5.13	1.97	640.86			
127	5		35	35	120	140,2	28	180	184	92	152,4	50	416,1	M16	5/8-11 UNC	BAS-311-ST-140.2/120-W1
			508	508	4.72	5.52	1.10	7.09	7.24	3.62	6.00	1.97	915.42			

Materials / Ordering Options / Examples

- * SAE Single-Part Counterflange made of Steel S355J0 or equivalent, blank (oiled) with Metric tapped holes **BAS-...-ST-**/**-W1**
- * SAE Single-Part Counterflange made of Stainless Steel V4A – 1.4404 (on request) with Metric tapped holes **BAS-...-ST-**/**-W5**
- * SAE Single-Part Counterflange made of Steel S355J0 or equivalent, blank (oiled) with size of Metric tapped holes deviating from the standard (e.g. M14) **BAS-...-ST-**/**-M14-W1**
- * SAE Single-Part Counterflange made of Steel S355J0 or equivalent, blank (oiled) with UNC tapped holes **BAS-...-ST-**/**-U-W1**

Please always indicate ØB / ØA.

¹ The maximum working pressure PN (bar/PSI) applies only to the flange itself and depends on the bolts used (Grade 8.8 / 10.9). The actual maximum working pressure depends on the thickness and the quality of the tube used.

³ Alternative options shown in brackets are available on request.

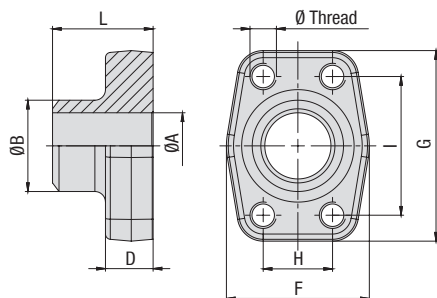

SAE Single-Part Butt-Weld Counterflange for High Pressure Tubes (Schedule 80/160/XXS)
 Type BAS-ST • 6000 PSI Series

6000 PSI High Pressure Series (based on ISO 6162-2:2002)

Nominal Size		PN ¹ (bar/PSI)		Dimensions (mm/in)									Weight (kg/lbs) Ca. per 100	Ø Thread		Ordering Codes
DN	(in)	8.8	10.9 (MH)	ØA	ØB	D	F	G	H	I	L		Metric	UNC		
13	1/2	350	420	13	21,6	16,5	47	57	18,2	40,5	36	27,8	M8	5/16-18 UNC	BAS-601-ST-21.6/13-W1	
		5075	6090	.51	.85	.65	1.85	2.24	.72	1.59	1.42	61.16				
13	1/2	350	420	13	17,5	16,5	47	57	18,2	40,5	36	26,1	M8	5/16-18 UNC	BAS-601-ST-17.5/13-W1	
		5075	6090	.51	.69	.65	1.85	2.24	.72	1.59	1.42	57.42				
19	3/4	350	420	19	28	19,5	54	72	23,8	50,8	36	49,0	M10	3/8-16 UNC	BAS-602-ST-28/19-W1	
		5075	6090	.75	1.10	.77	2.13	2.83	.94	2.00	1.42	107.80				
25	1	350	420	25	34	24,5	68	82	27,8	57,2	41	67,5	M12	7/16-14 UNC	BAS-603-ST-34/25-W1	
		5075	6090	.98	1.34	.96	2.68	3.23	1.09	2.25	1.61	148.50				
32	1-1/4	350	420	32	42,8	27,5	79	95	31,8	66,6	44	106,3	M12	1/2-13 UNC	BAS-604-ST-42.8/32-W1	
		5075	6090	1.26	1.69	1.08	3.11	3.74	1.25	2.62	1.73	233.86				
32	1-1/4	350	420	32	42,8	27,5	79	95	31,8	66,6	44	103,2	M14		BAS-604-ST-42.8/32-M14-W1	
		5075	6090	1.26	1.69	1.08	3.11	3.74	1.25	2.62	1.73	227.04				
32	1-1/4	350	420	29	42,8	27,5	79	95	31,8	66,6	44	101,0	M12	1/2-13 UNC	BAS-604-ST-42.8/29-W1 (SCH 160)	
		5075	6090	1.14	1.69	1.08	3.11	3.74	1.25	2.62	1.73	222.20				
32	1-1/4	350	420	29	42,8	27,5	79	95	31,8	66,6	44	113,3	M14		BAS-604-ST-42.8/29-M14-W1	
		5075	6090	1.14	1.69	1.08	3.11	3.74	1.25	2.62	1.73	249.26				
38	1-1/2	350	420	38	48,3	31	88	108	36,5	79,3	56	182,4	M16	5/8-11 UNC	BAS-605-ST-48.6/38-W1	
		5075	6090	1.50	1.90	1.22	3.46	4.25	1.44	3.12	2.20	401.28				
38	1-1/2	350	420	32	48,3	31	88	108	36,5	79,3	56	180,0	M16	5/8-11 UNC	BAS-605-ST-48.6/32-W1 (SCH 160)	
		5075	6090	1.26	1.90	1.22	3.46	4.25	1.44	3.12	2.20	396.00				
51	2	350	420	51	61	37	118	137	44,5	96,8	65	287,3	M20	3/4-10 UNC	BAS-606-ST-61/51-W1	
		5075	6090	2.01	2.40	1.46	4.65	5.39	1.75	3.81	2.56	632.06				
51	2	350	420	43	61	37	118	137	44,5	96,8	65	326,6	M20	3/4-10 UNC	BAS-606-ST-61/43-W1 (SCH 160)	
		5075	6090	1.69	2.40	1.46	4.65	5.39	1.75	3.81	2.56	718.52				
64	2-1/2	350	420	51	76,1	45	150	180	58,7	123,8	80	728,0	M24		BAS-606-ST-76.1/51-W1	
		5075	6090	2.01	3.00	1.77	5.91	7.09	2.31	4.87	3.15	1601.60				
64	2-1/2	350	420	60,5	90	45	150	180	58,7	123,8	80	751,5	M24		BAS-607-ST-90/60.5-W1 (SCH XXS)	
		5075	6090	2.38	3.54	1.77	5.91	7.09	2.31	4.87	3.15	1653.30				
76	3	350	420	90	67,7	152,4	208	71,4	178	90	55	1305,0	M30		BAS-608-ST-90/67-W1 (SCH 160)	
		5075	6090	3.54	2.67	6.00	8.19	2.81	7.01	3.54	2.17	2871.00				
76	3	350	420	90	58,4	152,4	208	71,4	178	90	55	1305,0	M30		BAS-608-ST-90/58-W1 (SCH XXS)	
		5075	6090	3.54	2.30	6.00	8.19	2.81	7.01	3.54	2.17	2871.00				

¹ The maximum working pressure PN (bar/PSI) applies only to the flange itself and depends on the bolts used (Grade 8.8 / 10.9). The actual maximum working pressure depends on the thickness and the quality of the tube used.

Materials / Ordering Options / Examples

- * SAE Single-Part Counterflange made of Steel S355J0 or equivalent, blank (oiled) with Metric tapped holes BAS-...-ST-*/**-W1
- * SAE Single-Part Counterflange made of Stainless Steel V4A – 1.4404 (on request) with Metric tapped holes BAS-...-ST-*/**-W5
- * SAE Single-Part Counterflange made of Steel S355J0 or equivalent, blank (oiled) with size of Metric tapped holes deviating from the standard (e.g. M14) BAS-...-ST-*/**-M14-W1
- * SAE Single-Part Counterflange made of Steel S355J0 or equivalent, blank (oiled) with UNC tapped holes BAS-...-ST-*/**-U-W1

Please always indicate ØB / ØA.



**SAE Single-Part Butt-Weld Flange for Low Pressure Tubes (Schedule 40)
Type BFX-STRE • 3000 PSI Series**

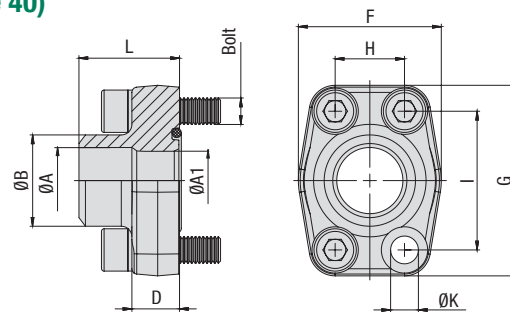

3000 PSI Standard Pressure Series (based on ISO 6162-1:2002)

Nominal Size DN	(in)	PN ¹ (bar/PSI)		Dimensions (mm/in)										Weight (kg/lbs) ca. per 100	for Bolts		Ordering Codes
		8.8	10.9 (MH)	ØA	ØA1	ØB	D	F	G	H	I	L	ØK ³		Metric ³	UNC	
13	1/2	350	350	16	13	22	16	47	57	17,5	38,1	36	8,7	25,6	M8x30	5/16-18 UNC x 1-1/4	BFX-301-STRE-22/16-W1
		5075	5075	.63	.51	.87	.63	1.85	2.24	.69	1.50	1.42	.34	56.32			
19	3/4	350	350	21,5	19	28	18	50	67	22,3	47,6	36	10,5	34,0	M10x35	3/8-16 UNC x 1-1/2	BFX-302-STRE-28/21.5-W1
		5075	5075	.85	.75	1.10	.71	1.97	2.64	.88	1.87	1.42	.41	74.80			
25	1	250	315	27	25	35	18	54	72	26,2	52,4	38	10,5	40,0	M10x35	3/8-16 UNC x 1-1/2	BFX-303-STRE-35/27-W1
		3625	4568	1.06	.98	1.38	.71	2.13	2.83	1.03	2.06	1.50	.41	88.00			
32	1-1/4	200	250	36	31	43	21	68	82	30,2	58,7	41	11,5 (13,5)	61,7	M10x40 (M12x40)	7/16-14 UNC x 1-1/2	BFX-304-STRE-43/36-W1
		2900	3625	1.42	1.22	1.69	.83	2.68	3.23	1.19	2.31	1.61	.45 (.53)	135.74			
38	1-1/2	200	200	42	38	49	25	79	96	35,7	69,9	44	13,5 (14,5)	92,8	M12x45 (M14x45)	1/2-13 UNC x 1-3/4	BFX-305-STRE-49/42-W1
		2900	2900	1.65	1.50	1.93	.98	3.11	3.78	1.41	2.75	1.73	.53 (.57)	204.16			
51	2	160	200	42	42	49	25,5	88	102	42,9	77,8	45	13,5 (14,5)	116,4	M12x45 (M14x45)	1/2-13 UNC x 1-3/4	BFX-306-STRE-49/42-W1
		2320	2900	1.65	1.65	1.93	1.00	3.46	4.02	1.69	3.06	1.77	.53 (.57)	256.08			
51	2	160	200	53	49	61	25,5	88	102	42,9	77,8	45	13,5 (14,5)	115,8	M12x45 (M14x45)	1/2-13 UNC x 1-3/4	BFX-306-STRE-61/53-W1
		2320	2900	2.09	1.93	2.40	1.00	3.46	4.02	1.69	3.06	1.77	.53 (.57)	254.76			
64	2-1/2	100	160	53	53	61	26	101	115	50,8	88,9	50	13,5 (14,5)	148,3	M12x45 (M14x45)	1/2-13 UNC x 1-3/4	BFX-307-STRE-61/53-W1
		1450	2320	2.09	2.09	2.40	1.02	3.98	4.53	2.00	3.50	1.97	.53 (.57)	326.26			
64	2-1/2	100	160	70	62	77	26	101	115	50,8	88,9	50	13,5 (14,5)	143,2	M12x45 (M14x45)	1/2-13 UNC x 1-3/4	BFX-307-STRE-77/70-W1
		1450	2320	2.76	2.44	3.03	1.02	3.98	4.53	2.00	3.50	1.97	.53 (.57)	315.04			
76	3	100	160	82	74	90	27,5	127	137	61,9	106,4	50	17	200,0	M16x50	5/8-11 UNC x 2	BFX-308-STRE-90/82-W1
		1450	2320	3.23	2.91	3.54	1.08	5.00	5.39	2.44	4.19	1.97	.67	440.00			
89	3-1/2	35	35	82	82	90	27,5	138	155	69,9	120,7	50	17	244,0	M16x50	5/8-11 UNC x 2	BFX-309-STRE-90/82-W1
		508	508	3.23	3.23	3.54	1.08	5.43	6.10	2.75	4.75	1.97	.67	536.80			
89	3-1/2	35	35	70	70	77	27,5	138	155	69,9	120,7	50	17	243,6	M16x50	5/8-11 UNC x 2	BFX-309-STRE-77/70-W1
		508	508	2.76	2.76	3.03	1.08	5.43	6.10	2.75	4.75	1.97	.67	535.92			
102	4	35	35	82	82	90	27,5	147	163	77,8	130,2	50	17	283,1	M16x50	5/8-11 UNC x 2	BFX-310-STRE-90/82-W1
		508	508	3.23	3.23	3.54	1.08	5.79	6.42	3.06	5.13	1.97	.67	622.82			
102	4	35	35	107	102	115	27,5	147	163	77,8	130,2	50	17	254,3	M16x50	5/8-11 UNC x 2	BFX-310-STRE-115/107-W1
		508	508	4.21	4.02	4.53	1.08	5.79	6.42	3.06	5.13	1.97	.67	559.46			
127	5	35	35	131	120	140,2	28	180	184	92	152,4	50	17	381,9	M16x55	5/8-11 UNC x 2-1/4	BFX-311-STRE-140/131-W1
		508	508	5.16	4.72	5.52	1.10	7.09	7.24	3.62	6.00	1.97	.67	840.18			

Materials / Ordering Options / Examples

- * SAE Single-Part Flange (without O-ring) made of Steel S355J0 or equivalent, blank (oiled)
- * SAE Single-Part Flange (without O-ring) made of Stainless Steel V4A – 1.4404 (on request)

BFX-...-STRE--**/**-W1**
BFX-...-STRE--**/**-W5**

- * Kit including Metric bolts 8.8, spring rings, O-ring made of NBR (Buna-N®)
- * Kit including Metric bolts 8.8, spring rings, O-ring made of FKM/FPM (Viton®)
- * Kit including Metric bolts 10.9, spring rings, O-ring made of NBR (Buna-N®)
- * Kit including UNC bolts (Grade 8), spring rings, O-ring made of NBR (Buna-N®)

BFX-...-STRE--**/**-W46-K**
BFX-...-STRE--**/**-V-W46-K**
BFX-...-STRE--**/**-MH-W1-K**
BFX-...-STRE--**/**-U-W1-K**

Please always indicate ØB / ØA.

¹ The maximum working pressure PN (bar/PSI) applies only to the flange itself and depends on the bolts used (Grade 8.8 / 10.9). The actual maximum working pressure depends on the thickness and the quality of the tube used.

³ Alternative options shown in brackets are available on request.



SAE Single-Part Butt-Weld Counterflange for Low Pressure Tubes (Schedule 40) Type BAS-STRE - 3000 PSI Series

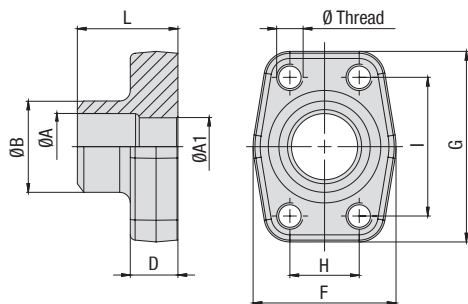

3000 PSI Standard Pressure Series (based on ISO 6162-1:2002)

Nominal Size	DN	(in)	PN ¹ (bar/PSI)		Dimensions (mm/in)										Weight (^{kg} /lbs) ca.			for Bolts		Ordering Codes
			8.8	10.9 (MH)	ØA	ØA1	ØB	D	F	G	H	I	L	per 100	Metric ³	UNC				
13	1/2		350	350	16	13	22	16	47	57	17,5	38,1	36	26,7	M8	5/16-18 UNC	BAS-301-STRE-22/16-W1			
			5075	5075	.63	.51	.87	.63	1.85	2.24	.69	1.50	1.42	58.74						
19	3/4		350	350	21,5	19	28	18	50	67	22,3	47,6	36	36,3	M10	3/8-16 UNC	BAS-302-STRE-28/21.5-W1			
			5075	5075	.85	.75	1.10	.71	1.97	2.64	.88	1.87	1.42	79.86						
25	1		250	315	27	25	35	18	54	72	26,2	52,4	38	43,1	M10	3/8-16 UNC	BAS-303-STRE-35/27-W1			
			3625	4568	1.06	.98	1.38	.71	2.13	2.83	1.03	2.06	1.50	94.82						
32	1-1/4		200	250	36	31	43	21	68	82	30,2	58,7	41	65,3	M10 (M12)	7/16-14 UNC	BAS-304-STRE-43/36-W1			
			2900	3625	1.42	1.22	1.69	.83	2.68	3.23	1.19	2.31	1.61	143.66						
38	1-1/2		200	200	42	38	49	25	79	96	35,7	69,9	44	97,1	M12 (M14)	1/2-13 UNC	BAS-305-STRE-49/42-W1			
			2900	2900	1.65	1.50	1.93	.98	3.11	3.78	1.41	2.75	1.73	213.62						
51	2		160	200	42	42	49	25,5	88	102	42,9	77,8	45	0,0	M12 (M14)	1/2-13 UNC	BAS-306-STRE-49/42-W1			
			2320	2900	1.65	1.65	1.93	1.00	3.46	4.02	1.69	3.06	1.77	.00						
51	2		160	200	53	49	61	25,5	88	102	42,9	77,8	45	119,7	M12 (M14)	1/2-13 UNC	BAS-306-STRE-61/53-W1			
			2320	2900	2.09	1.93	2.40	1.00	3.46	4.02	1.69	3.06	1.77	263.34						
64	2-1/2		100	160	53	53	61	26	101	115	50,8	88,9	50	150,1	M12 (M14)	1/2-13 UNC	BAS-307-STRE-61/53-W1			
			1450	2320	2.09	2.09	2.40	1.02	3.98	4.53	2.00	3.50	1.97	330.22						
64	2-1/2		100	160	70	62	77	26	101	115	50,8	88,9	50	149,2	M12 (M14)	1/2-13 UNC	BAS-307-STRE-77/70-W1			
			1450	2320	2.76	2.44	3.03	1.02	3.98	4.53	2.00	3.50	1.97	328.24						
76	3		100	160	82	74	90	27,5	127	137	61,9	106,4	50	211,7	M16	5/8-11 UNC	BAS-308-STRE-90/82-W1			
			1450	2320	3.23	2.91	3.54	1.08	5.00	5.39	2.44	4.19	1.97	465.74						
89	3-1/2		35	35	82	82	90	27,5	138	155	69,9	120,7	50	255,1	M16	5/8-11 UNC	BAS-309-STRE-90/82-W1			
			508	508	3.23	3.23	3.54	1.08	5.43	6.10	2.75	4.75	1.97	561.22						
89	3-1/2		35	35	70	70	77	27,5	138	155	69,9	120,7	50	268,9	M16	5/8-11 UNC	BAS-309-STRE-77/70-W1			
			508	508	2.76	2.76	3.03	1.08	5.43	6.10	2.75	4.75	1.97	591.67						
102	4		35	35	82	82	90	27,5	147	163	77,8	130,2	50	289,2	M16	5/8-11 UNC	BAS-310-STRE-90/82-W1			
			508	508	3.23	3.23	3.54	1.08	5.79	6.42	3.06	5.13	1.97	636.24						
102	4		35	35	107	102	115	27,5	147	163	77,8	130,2	50	257,4	M16	5/8-11 UNC	BAS-310-STRE-115/107-W1			
			508	508	4.21	4.02	4.53	1.08	5.79	6.42	3.06	5.13	1.97	566.28						
127	5		35	35	131	120	140,2	28	180	184	92	152,4	50	383,2	M16	5/8-11 UNC	BAS-311-STRE-140/131-W1			
			508	508	5.16	4.72	5.52	1.10	7.09	7.24	3.62	6.00	1.97	843.04						

¹ The maximum working pressure PN (bar/PSI) applies only to the flange itself and depends on the bolts used (Grade 8.8 / 10.9). The actual maximum working pressure depends on the thickness and the quality of the tube used.

³ Alternative options shown in brackets are available on request.

Materials / Ordering Options / Examples

- * SAE Single-Part Counterflange made of Steel S355J0 or equivalent, blank (oiled) with Metric tapped holes BAS-...-STRE-*/**-W1
- * SAE Single-Part Counterflange made of Stainless Steel V4A – 1.4404 (on request) with Metric tapped holes BAS-...-STRE-*/**-W5
- * SAE Single-Part Counterflange made of Steel S355J0 or equivalent, blank (oiled) with size of Metric tapped holes deviating from the standard (e.g. M14) BAS-...-STRE-*/**-M14-W1
- * SAE Single-Part Counterflange made of Steel S355J0 or equivalent, blank (oiled) with UNC tapped holes BAS-...-STRE-*/**-U-W1

Please always indicate ØB / ØA.



SAE Single-Part Butt-Weld Flange for Metric Tubes
Type BFX-SRE • 3000 PSI Series

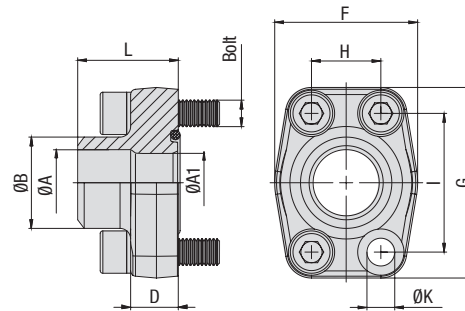

3000 PSI Standard Pressure Series (based on ISO 6162-1:2002)

Nominal Size		PN ¹ (bar/PSI)		Dimensions (mm/in)										Weight for Bolts (kg/lbs) ca.			Ordering Codes	
DN	(in)	8.8	10.9 (MH)	ØA	ØA1	ØB	D	F	G	H	I	L	ØK ³	per 100	Metric ³	UNC		
13	1/2	350	350	14	14	20	16	47	57	17,5	38,1	36	8,7	24,4	M8x30	5/16-18 UNC x 1-1/4	BFX-301-SRE-20/14-W1	
		5075	5075	.55	.55	.79	.63	1.85	2.24	.69	1.50	1.42	.34	53.68				
13	1/2	350	350	16	13	22	16	47	57	17,5	38,1	36	8,7	24,9	M8x30	5/16-18 UNC x 1-1/4	BFX-301-SRE-22/16-W1	
		5075	5075	.63	.51	.87	.63	1.85	2.24	.69	1.50	1.42	.34	54.78				
19	3/4	350	350	19	19	25	18	50	67	22,3	47,6	36	10,5	32,4	M10x35	3/8-16 UNC x 1-1/2	BFX-302-SRE-25/19-W1	
		5075	5075	.75	.75	.98	.71	1.97	2.64	.88	1.87	1.42	.41	71.28				
19	3/4	350	350	21,5	19	28	18	50	67	22,3	47,6	36	10,5	33,9	M10x35	3/8-16 UNC x 1-1/2	BFX-302-SRE-28/21,5-W1	
		5075	5075	.85	.75	1.10	.71	1.97	2.64	.88	1.87	1.42	.41	74.58				
25	1	250	315	22	22	30	18	54	72	26,2	52,4	38	10,5	41,0	M10x35	3/8-16 UNC x 1-1/2	BFX-303-SRE-30/22-W1	
		3625	4568	.87	.87	1.18	.71	2.13	2.83	1.03	2.06	1.50	.41	90.20				
25	1	250	315	27	25	35	18	54	72	26,2	52,4	38	10,5	40,6	M10x35	3/8-16 UNC x 1-1/2	BFX-303-SRE-35/27-W1	
		3625	4568	1.06	.98	1.38	.71	2.13	2.83	1.03	2.06	1.50	.41	89.32				
32	1-1/4	200	250	30	30	38	21	68	82	30,2	58,7	41	11,5 (13,5)	60,6	M10x40 (M12x40)	7/16-14 UNC x 1-1/2	BFX-304-SRE-38/30-W1	
		2900	3625	1.18	1.18	1.50	.83	2.68	3.23	1.19	2.31	1.61	.45 (.53)	133.32				
32	1-1/4	200	250	36	31	43	21	68	82	30,2	58,7	41	11,5 (13,5)	61,7	M10x40 (M12x40)	7/16-14 UNC x 1-1/2	BFX-304-SRE-43/36-W1	
		2900	3625	1.42	1.22	1.69	.83	2.68	3.23	1.19	2.31	1.61	.45 (.53)	135.74				
38	1-1/2	200	200	30	30	38	25	79	96	35,7	69,9	44	13,5 (14,5)	97,4	M12x45 (M14x45)	1/2-13 UNC x 1-3/4	BFX-305-SRE-38/30-W1	
		2900	2900	1.18	1.18	1.50	.98	3.11	3.78	1.41	2.75	1.73	.53 (.57)	214.28				
38	1-1/2	200	200	36	36	42	25	79	96	35,7	69,9	44	13,5 (14,5)	91,3	M12x45 (M14x45)	1/2-13 UNC x 1-3/4	BFX-305-SRE-42/36-W1	
		2900	2900	1.42	1.42	1.65	.98	3.11	3.78	1.41	2.75	1.73	.53 (.57)	200.86				
38	1-1/2	200	200	38	38	49	25	79	96	35,7	69,9	44	13,5 (14,5)	95,8	M12x45 (M14x45)	1/2-13 UNC x 1-3/4	BFX-305-SRE-49/38-W1	
		2900	2900	1.50	1.50	1.93	.98	3.11	3.78	1.41	2.75	1.73	.53 (.57)	210.76				
51	2	160	200	49	49	61	25,5	88	102	42,9	77,8	45	13,5 (14,5)	118,4	M12x45 (M14x45)	1/2-13 UNC x 1-3/4	BFX-306-SRE-61/49-W1	
		2320	2900	1.93	1.93	2.40	1.00	3.46	4.02	1.69	3.06	1.77	.53 (.57)	260.48				
64	2-1/2	100	160	62	62	77	26	101	115	50,8	88,9	50	13,5 (14,5)	152,1	M12x45 (M14x45)	1/2-13 UNC x 1-3/4	BFX-307-SRE-77/62-W1	
		1450	2320	2.44	2.44	3.03	1.02	3.98	4.53	2.00	3.50	1.97	.53 (.57)	334.62				
76	3	100	160	62	62	77	27,5	127	137	61,9	106,4	50	17	229,3	M16x50	5/8-11 UNC x 2	BFX-308-SRE-77/62-W1	
		1450	2320	2.44	2.44	3.03	1.08	5.00	5.39	2.44	4.19	1.97	.67	504.46				

Materials / Ordering Options / Examples

- * SAE Single-Part Flange (without O-ring) made of Steel S355J0 or equivalent, blank (oiled)
- * SAE Single-Part Flange (without O-ring) made of Stainless Steel V4A – 1.4404 (on request)

BFX-...-SRE--**/W1**
BFX-...-SRE--**/W5**

- * Kit including Metric bolts 8.8, spring rings, O-ring made of NBR (Buna-N®)
- * Kit including Metric bolts 8.8, spring rings, O-ring made of FKM/FPM (Viton®)
- * Kit including Metric bolts 10.9, spring rings, O-ring made of NBR (Buna-N®)
- * Kit including UNC bolts (Grade 8), spring rings, O-ring made of NBR (Buna-N®)

BFX-...-SRE--**/W46-K**
BFX-...-SRE--**/V-W46-K**
BFX-...-SRE--**/MH-W1-K**
BFX-...-SRE--**/U-W1-K**

Please always indicate ØB / ØA.

¹ The maximum working pressure PN (bar/PSI) applies only to the flange itself and depends on the bolts used (Grade 8.8 / 10.9). The actual maximum working pressure depends on the thickness and the quality of the tube used.

³ Alternative options shown in brackets are available on request.



SAE Single-Part Butt-Weld Flange for Metric Tubes
Type BFX-SRE - 6000 PSI Series

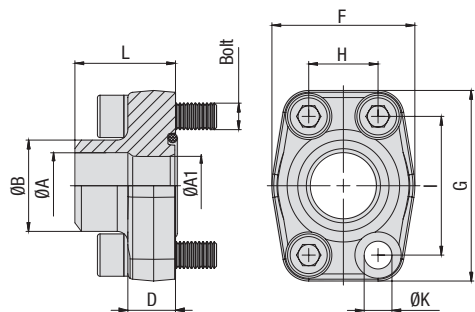

6000 PSI High Pressure Series (based on ISO 6162-2:2002)

C

Nominal Size	DN	(in)	PN ¹ (bar/PSI)		Dimensions (mm/in)										Weight (kg/lbs) Ca. per 100	for Bolts		Ordering Codes
			8.8	10.9 (MH)	ØA	ØA1	ØB	D	F	G	H	I	L	ØK		Metric	UNC	
13	1/2	350	420	14	14	20	16,5	47	57	18,2	40,5	36	8,7	24,0	M8x30	5/16-18 UNC x 1-1/4	BFX-601-SRE-20/14-W1	
		5075	6090	.55	.55	.79	.65	1.85	2.24	.72	1.59	1.42	.34	52.80				
19	3/4	350	420	14	14	20	19,5	54	72	23,8	50,8	36	10,5	48,7	M10x35	3/8-16 UNC x 1-1/2	BFX-602-SRE-20/14-W1	
		5075	6090	.55	.55	.79	.77	2.13	2.83	.94	2.00	1.42	.41	107.14				
19	3/4	350	420	17	17	25	19,5	54	72	23,8	50,8	36	10,5	48,8	M10x35	3/8-16 UNC x 1-1/2	BFX-602-SRE-25/17-W1	
		5075	6090	.67	.67	.98	.77	2.13	2.83	.94	2.00	1.42	.41	107.36				
25	1	350	420	17	17	25	24,5	68	82	27,8	57,2	44	13	72,7	M12x45	7/16-14 UNC x 1-3/4	BFX-603-SRE-25/17-W1 ²	
		5075	6090	.67	.67	.98	.96	2.68	3.23	1.09	2.25	1.73	.51	159.94				
25	1	350	420	22	22	30	24,5	68	82	27,8	57,2	44	13	72,1	M12x45	7/16-14 UNC x 1-3/4	BFX-603-SRE-30/22-W1 ²	
		5075	6090	.87	.87	1.18	.96	2.68	3.23	1.09	2.25	1.73	.51	158.62				
32	1-1/4	350	420	22	22	30	27,5	79	95	31,6	66,6	44	13,5	155,7	M12x45	1/2-13 UNC x 1-3/4	BFX-604-SRE-30/22-W1	
		5075	6090	.87	.87	1.18	1.08	3.11	3.74	1.24	2.62	1.73	.53	342.54				
32	1-1/4	350	420	22	22	30	27,5	79	95	31,6	66,6	44	15	102,8	M14x45		BFX-604-SRE-30/22-M14-W1	
		5075	6090	.87	.87	1.18	1.08	3.11	3.74	1.24	2.62	1.73	.59	226.16				
32	1-1/4	350	420	26	26	38	27,5	79	95	31,6	66,6	44	13,5	109,4	M12x45	1/2-13 UNC x 1-3/4	BFX-604-SRE-38/26-W1	
		5075	6090	1.02	1.02	1.50	1.08	3.11	3.74	1.24	2.62	1.73	.53	240.68				
32	1-1/4	350	420	26	26	38	27,5	79	95	31,6	66,6	44	15	105,0	M14x45		BFX-604-SRE-38/26-M14-W1	
		5075	6090	1.02	1.02	1.50	1.08	3.11	3.74	1.24	2.62	1.73	.59	231.00				
38	1-1/2	350	420	26	26	38	28	88	108	36,5	79,3	56	17	171,6	M16x55	5/8-11 UNC x 2-1/4	BFX-605-SRE-38/26-W1	
		5075	6090	1.02	1.02	1.50	1.10	3.46	4.25	1.44	3.12	2.20	.67	377.52				
38	1-1/2	350	420	32	32	49	28	88	108	36,5	79,3	56	17	173,7	M16x55	5/8-11 UNC x 2-1/4	BFX-605-SRE-49/32-W1	
		5075	6090	1.26	1.26	1.93	1.10	3.46	4.25	1.44	3.12	2.20	.67	382.14				
38	1-1/2	350	420	40	40	61	28	88	108	36,5	79,3	56	17	180,8	M16x55	5/8-11 UNC x 2-1/4	BFX-605-SRE-61/40-W1	
		5075	6090	1.57	1.57	2.40	1.10	3.46	4.25	1.44	3.12	2.20	.67	397.76				
51	2	350	420	40	40	61	37	118	137	44,5	96,8	65	21	317,3	M20x70	3/4-10 UNC x 2-3/4	BFX-606-SRE-61/40-W1	
		5075	6090	1.57	1.57	2.40	1.46	4.65	5.39	1.75	3.81	2.56	.83	698.06				
51	2	350	420	50	48	76	28	118	137	44,5	96,8	80	21	308,2	M20x55	3/4-10 UNC x 2-1/4	BFX-606-SRE-76/50-W1	
		5075	6090	1.97	1.89	2.99	1.10	4.65	5.39	1.75	3.81	3.15	.83	678.04				

¹ The maximum working pressure PN (bar/PSI) applies only to the flange itself and depends on the bolts used (Grade 8.8 / 10.9). The actual maximum working pressure depends on the thickness and the quality of the tube used.

² For UNC threaded bolts, use hexagon head bolts only. Please note that these do not belong to our product range.

Materials / Ordering Options / Examples

- * SAE Single-Part Flange (without O-ring) made of Steel S355J0 or equivalent, blank (oiled) **BFX-...-SRE-...-W1**
- * SAE Single-Part Flange (without O-ring) made of Stainless Steel V4A - 1.4404 (on request) **BFX-...-SRE-...-W5**
- * Kit including Metric bolts 8.8, spring rings, O-ring made of NBR (Buna-N®) **BFX-...-SRE-...-W46-K**
- * Kit including Metric bolts 8.8, spring rings, O-ring made of FKM/FPM (Viton®) **BFX-...-SRE-...-V-W46-K**
- * Kit including Metric bolts 10.9, spring rings, O-ring made of NBR (Buna-N®) **BFX-...-SRE-...-MH-W1-K**
- * Kit including UNC bolts (Grade 8), spring rings, O-ring made of NBR (Buna-N®) **BFX-...-SRE-...-U-W1-K**

Please always indicate ØB / ØA.



SAE Single-Part Butt-Weld Counterflange for Metric Tubes
Type BAS-SRE • 3000 PSI Series

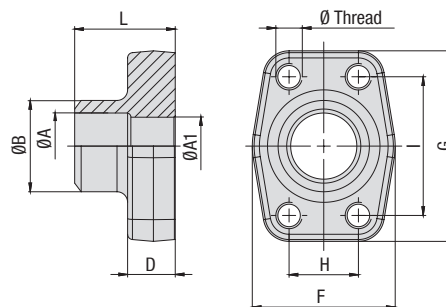

3000 PSI Standard Pressure Series (based on ISO 6162-1:2002)

Nominal Size		PN ¹ (bar/PSI)		Dimensions (mm/in)										Weight (kg/lbs) ca.		Ø Thread		Ordering Codes
DN	(in)	8.8	10.9 (MH)	ØA	ØA1	ØB	D	F	G	H	I	L	per 100	Metric ³	UNC			
13	1/2	350	350	14	14	20	16	47	57	17,5	38,1	36	26,1	M8	5/16-18 UNC	BAS-301-SRE-20/14-W1		
		5075	5075	.55	.55	.79	.63	1.85	2.24	.69	1.50	1.42	57.42					
13	1/2	350	350	16	13	22	16	47	57	17,5	38,1	36	26,7	M8	5/16-18 UNC	BAS-301-SRE-22/16-W1		
		5075	5075	.63	.51	.87	.63	1.85	2.24	.69	1.50	1.42	58.74					
19	3/4	350	350	19	19	25	18	50	67	22,3	47,6	36	34,5	M10	3/8-16 UNC	BAS-302-SRE-25/19-W1		
		5075	5075	.75	.75	.98	.71	1.97	2.64	.88	1.87	1.42	75.90					
19	3/4	350	350	21,5	19	28	18	50	67	22,3	47,6	36	35,9	M10	3/8-16 UNC	BAS-302-SRE-28/21.5-W1		
		5075	5075	.85	.75	1.10	.71	1.97	2.64	.88	1.87	1.42	78.98					
25	1	250	315	22	22	30	18	54	72	26,2	52,4	38	43,6	M10	3/8-16 UNC	BAS-303-SRE-30/22-W1		
		3625	4568	.87	.87	1.18	.71	2.13	2.83	1.03	2.06	1.50	95.92					
25	1	250	315	27	25	35	18	54	72	26,2	52,4	38	42,9	M10	3/8-16 UNC	BAS-303-SRE-35/27-W1		
		3625	4568	1.06	.98	1.38	.71	2.13	2.83	1.03	2.06	1.50	94.38					
32	1-1/4	200	250	30	30	38	21	68	82	30,2	58,7	41	63,9	M10 (M12)	7/16-14 UNC	BAS-304-SRE-38/30-W1		
		2900	3625	1.18	1.18	1.50	.83	2.68	3.23	1.19	2.31	1.61	140.58					
32	1-1/4	200	250	36	31	43	21	68	82	30,2	58,7	41	64,6	M10 (M12)	7/16-14 UNC	BAS-304-SRE-43/36-W1		
		2900	3625	1.42	1.22	1.69	.83	2.68	3.23	1.19	2.31	1.61	142.12					
38	1-1/2	200	200	30	30	38	25	79	96	35,7	69,9	44	101,9	M12 (M14)	1/2-13 UNC	BAS-305-SRE-38/30-W1		
		2900	2900	1.18	1.18	1.50	.98	3.11	3.78	1.41	2.75	1.73	224.18					
38	1-1/2	200	200	36	36	42	25	79	96	35,7	69,9	44	95,0	M12 (M14)	1/2-13 UNC	BAS-305-SRE-42/36-W1		
		2900	2900	1.42	1.42	1.65	.98	3.11	3.78	1.41	2.75	1.73	209.00					
38	1-1/2	200	200	38	38	49	25	79	96	35,7	69,9	44	101,6	M12 (M14)	1/2-13 UNC	BAS-305-SRE-49/38-W1		
		2900	2900	1.50	1.50	1.93	.98	3.11	3.78	1.41	2.75	1.73	223.52					
51	2	160	200	49	49	61	25,5	88	102	42,9	77,8	45	123,2	M12 (M14)	1/2-13 UNC	BAS-306-SRE-61/49-W1		
		2320	2900	1.93	1.93	2.40	1.00	3.46	4.02	1.69	3.06	1.77	271.04					
64	2-1/2	100	160	62	62	77	26	101	115	50,8	88,9	50	159,6	M12 (M14)	1/2-13 UNC	BAS-307-SRE-77/62-W1		
		1450	2320	2.44	2.44	3.03	1.02	3.98	4.53	2.00	3.50	1.97	351.12					
76	3	100	160	62	62	77	27,5	127	137	61,9	106,4	50	235,3	M16	5/8-11 UNC	BAS-308-SRE-77/62-W1		
		1450	2320	2.44	2.44	3.03	1.08	5.00	5.39	2.44	4.19	1.97	517.66					

Materials / Ordering Options / Examples

- * SAE Single-Part Counterflange made of Steel S355J0 or equivalent, blank (oiled) with Metric tapped holes **BAS-...-SRE-**/**-W1**
- * SAE Single-Part Counterflange made of Stainless Steel V4A – 1.4404 (on request) with Metric tapped holes **BAS-...-SRE-**/**-W5**
- * SAE Single-Part Counterflange made of Steel S355J0 or equivalent, blank (oiled) with size of Metric tapped holes deviating from the standard (e.g. M14) **BAS-...-SRE-**/**-M14-W1**
- * SAE Single-Part Counterflange made of Steel S355J0 or equivalent, blank (oiled) with UNC tapped holes **BAS-...-SRE-**/**-U-W1**

Please always indicate ØB / ØA.

¹ The maximum working pressure PN (bar/PSI) applies only to the flange itself and depends on the bolts used (Grade 8.8 / 10.9). The actual maximum working pressure depends on the thickness and the quality of the tube used.

³ Alternative options shown in brackets are available on request.



SAE Single-Part Butt-Weld Counterflange for Metric Tubes
Type BAS-SRE - 6000 PSI Series

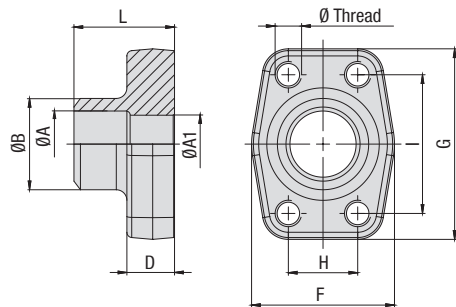

6000 PSI High Pressure Series (based on ISO 6162-2:2002)

C

Nominal Size	DN (in)	PN ¹ (bar/PSI)	Dimensions (mm/in)											Weight (kg/lbs) ca. per 100	for Bolts		Ordering Codes
			8.8	10.9 (MH)	ØA	ØA1	ØB	D	F	G	H	I	L		Metric	UNC	
13	1/2	350	420	14	14	20	16,5	47	57	18,2	40,5	36	25,6	M8	5/16-18 UNC	BAS-601-SRE-20/14-W1	
		5075	6090	.55	.55	.79	.65	1.85	2.24	.72	1.59	1.42	56.32				
19	3/4	350	420	14	14	20	19,5	54	72	23,8	50,8	36	51,7	M10	3/8-16 UNC	BAS-602-SRE-20/14-W1	
		5075	6090	.55	.55	.79	.77	2.13	2.83	.94	2.00	1.42	113.74				
19	3/4	350	420	17	17	25	19,5	54	72	23,8	50,8	36	51,3	M10	3/8-16 UNC	BAS-602-SRE-25/17-W1	
		5075	6090	.67	.67	.98	.77	2.13	2.83	.94	2.00	1.42	112.86				
25	1	350	420	17	17	25	24,5	68	82	27,8	57,2	44	76,5	M12	7/16-14 UNC	BAS-603-SRE-25/17-W1	
		5075	6090	.67	.67	.98	.96	2.68	3.23	1.09	2.25	1.73	168.30				
25	1	350	420	22	22	30	24,5	68	82	27,8	57,2	44	75,7	M12	7/16-14 UNC	BAS-603-SRE-30/22-W1	
		5075	6090	.87	.87	1.18	.96	2.68	3.23	1.09	2.25	1.73	166.54				
32	1-1/4	350	420	22	22	30	27,5	79	95	31,6	66,6	44	103,0	M12	1/2-13 UNC	BAS-604-SRE-30/22-W1	
		5075	6090	.87	.87	1.18	1.08	3.11	3.74	1.24	2.62	1.73	226.60				
32	1-1/4	350	420	22	22	30	27,5	79	95	31,6	66,6	44	106,8	M14		BAS-604-SRE-30/22-M14-W1	
		5075	6090	.87	.87	1.18	1.08	3.11	3.74	1.24	2.62	1.73	234.96				
32	1-1/4	350	420	26	26	38	27,5	79	95	31,6	66,6	44	105,0	M12	1/2-13 UNC	BAS-604-SRE-38/26-W1	
		5075	6090	1.02	1.02	1.50	1.08	3.11	3.74	1.24	2.62	1.73	231.00				
32	1-1/4	350	420	26	26	38	27,5	79	95	31,6	66,6	44	110,2	M14		BAS-604-SRE-38/26-M14-W1	
		5075	6090	1.02	1.02	1.50	1.08	3.11	3.74	1.24	2.62	1.73	242.44				
38	1-1/2	350	420	26	26	38	28	88	108	36,5	79,3	56	177,3	M16	5/8-11 UNC	BAS-605-SRE-38/26-W1	
		5075	6090	1.02	1.02	1.50	1.10	3.46	4.25	1.44	3.12	2.20	390.06				
38	1-1/2	350	420	32	32	49	28	88	108	36,5	79,3	56	180,4	M16	5/8-11 UNC	BAS-605-SRE-49/32-W1	
		5075	6090	1.26	1.26	1.93	1.10	3.46	4.25	1.44	3.12	2.20	396.88				
38	1-1/2	350	420	40	40	61	28	88	108	36,5	79,3	56	185,5	M16	5/8-11 UNC	BAS-605-SRE-61/40-W1	
		5075	6090	1.57	1.57	2.40	1.10	3.46	4.25	1.44	3.12	2.20	408.10				
51	2	350	420	40	40	61	37	118	137	44,5	96,8	70	352,8	M20	3/4-10 UNC	BAS-606-SRE-61/40-W1	
		5075	6090	1.57	1.57	2.40	1.46	4.65	5.39	1.75	3.81	2.76	776.16				
51	2	350	420	50	48	76	28	118	137	44,5	96,8	80	105,0	M20	3/4-10 UNC	BAS-606-SRE-76/50-W1	
		5075	6090	1.97	1.89	2.99	1.10	4.65	5.39	1.75	3.81	3.15	231.00				

¹ The maximum working pressure PN (bar/PSI) applies only to the flange itself and depends on the bolts used (Grade 8.8 / 10.9). The actual maximum working pressure depends on the thickness and the quality of the tube used.

Materials / Ordering Options / Examples

- * SAE Single-Part Counterflange made of Steel S355J0 or equivalent, blank (oiled) with Metric tapped holes BAS-...-SRE-*/**-W1
- * SAE Single-Part Counterflange made of Stainless Steel V4A – 1.4404 (on request) with Metric tapped holes BAS-...-SRE-*/**-W5
- * SAE Single-Part Counterflange made of Steel S355J0 or equivalent, blank (oiled) with size of Metric tapped holes deviating from the standard (e.g. M14) BAS-...-SRE-*/**-M14-W1
- * SAE Single-Part Counterflange made of Steel S355J0 or equivalent, blank (oiled) with UNC tapped holes BAS-...-SRE-*/**-U-W1

Please always indicate ØB / ØA.



SAE Single-Part Socket-Weld Flange
Type BFX-ES ▪ 3000 PSI Series

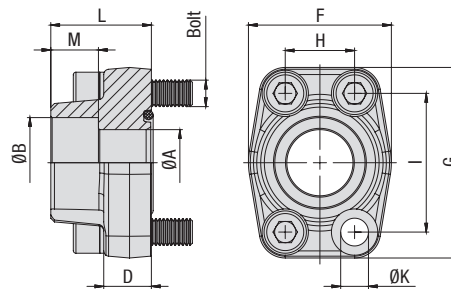

3000 PSI Standard Pressure Series (based on ISO 6162-1:2002)

Nominal Size	DN	(in)	PN ¹ (bar/PSI)	Dimensions (mm/in)										Weight (kg/lbs) ca. per 100	for Bolts		Ordering Codes	
				8.8	10.9 (MH)	ØA	ØB	D	F	G	H	I	L		M	ØK ³		Metric ³
13	1/2		350	350	13	21,6	16	47	57	17,5	38,1	36	18	8,7	27,7	M8x30	5/16-18 UNC x 1-1/4	BFX-301-ES-21.6/13-W1
			5075	5075	.51	.85	.63	1.85	2.24	.69	1.50	1.42	.71	.34	60.94			
13	1/2		350	350	13	17,5	16	47	57	17,5	38,1	36	18	8,7	28,6	M8x30	5/16-18 UNC x 1-1/4	BFX-301-ES-17.5/13-W1
			5075	5075	.51	.69	.63	1.85	2.24	.69	1.50	1.42	.71	.34	62.92			
13	1/2		350	350	13	20,3	16	47	57	17,5	38,1	36	18	8,7	28,8	M8x30	5/16-18 UNC x 1-1/4	BFX-301-ES-20.3/13-W1
			5075	5075	.51	.80	.63	1.85	2.24	.69	1.50	1.42	.71	.34	63.36			
19	3/4		350	350	19	27,2	18	50	67	22,3	47,6	36	18	10,5	37,7	M10x35	3/8-16 UNC x 1-1/2	BFX-302-ES-27.2/19-W1
			5075	5075	.75	1.07	.71	1.97	2.64	.88	1.87	1.42	.71	.41	82.94			
19	3/4		350	350	19	25,3	18	50	67	22,3	47,6	36	18	10,5	39,7	M10x35	3/8-16 UNC x 1-1/2	BFX-302-ES-25.3/19-W1
			5075	5075	.75	1.00	.71	1.97	2.64	.88	1.87	1.42	.71	.41	87.34			
25	1		250	315	25	34	18	54	72	26,2	52,4	38	18	10,5	44,8	M10x35	3/8-16 UNC x 1-1/2	BFX-303-ES-34/25-W1
			3625	4568	.98	1.34	.71	2.13	2.83	1.03	2.06	1.50	.71	.41	98.56			
25	1		250	315	25	30,3	18	54	72	26,2	52,4	38	18	10,5	47,3	M10x35	3/8-16 UNC x 1-1/2	BFX-303-ES-30.3/25-W1
			3625	4568	.98	1.19	.71	2.13	2.83	1.03	2.06	1.50	.71	.41	104.06			
32	1-1/4		200	250	32	42,8	21	68	82	30,2	58,7	41	20	11,5 (12,5)	64,3	M10x40 (M12x40)	7/16-14 UNC x 1-1/2	BFX-304-ES-42.8/32-W1
			2900	3625	1.26	1.69	.83	2.68	3.23	1.19	2.31	1.61	.79	.45 (.49)	141.46			
32	1-1/4		200	250	32	38,3	21	68	82	30,2	58,7	41	20	11,5 (12,5)	72,0	M10x40 (M12x40)	7/16-14 UNC x 1-1/2	BFX-304-ES-38.3/32-W1
			2900	3625	1.26	1.51	.83	2.68	3.23	1.19	2.31	1.61	.79	.45 (.49)	158.40			
38	1-1/2		200	200	38	48,6	25	79	96	35,7	69,9	44	22	13,5 (14,5)	109,4	M12x45 (M14x45)	1/2-13 UNC x 1-3/4	BFX-305-ES-48.6/38-W1
			2900	2900	1.50	1.91	.98	3.11	3.78	1.41	2.75	1.73	.87	.53 (.57)	240.68			
38	1-1/2		200	200	38	50,5	25	79	96	35,7	69,9	44	22	13,5 (14,5)	101,1	M12x45 (M14x45)	1/2-13 UNC x 1-3/4	BFX-305-ES-50.5/38-W1
			2900	2900	1.50	1.99	.98	3.11	3.78	1.41	2.75	1.73	.87	.53 (.57)	222.42			
51	2		160	200	51	61	25,5	88	102	42,9	77,8	45	24	13,5 (14,5)	125,7	M12x45 (M14x45)	1/2-13 UNC x 1-3/4	BFX-306-ES-61/51-W1
			2320	2900	2.01	2.40	1.00	3.46	4.02	1.69	3.06	1.77	.94	.53	276.54			
64	2-1/2		100	160	63	76,6	26	101	115	50,8	88,9	50	28	13,5 (14,5)	145,3	M12x45 (M14x45)	1/2-13 UNC x 1-3/4	BFX-307-ES-76.6/63-W1
			1450	2320	2.48	3.02	1.02	3.98	4.53	2.00	3.50	1.97	1.10	.53 (.57)	319.66			
76	3		100	100	73	90,5	27,5	127	137	61,9	106,4	50	28	17	212,7	M16x50	5/8-11 UNC x 2	BFX-308-ES-90.5/73-W1
			1450	1450	2.87	3.56	1.08	5.00	5.39	2.44	4.19	1.97	1.10	.67	467.94			
89	3-1/2		35	35	89	103	27,5	138	155	69,9	120,7	50	30	17	235,2	M16x50	5/8-11 UNC x 2	BFX-309-ES-103/89-W1
			508	508	3.50	4.06	1.08	5.43	6.10	2.75	4.75	1.97	1.18	.67	517.44			
102	4		35	35	99	115,5	27,5	147	163	77,8	130,2	50	30	17	282,8	M16x50	5/8-11 UNC x 2	BFX-310-ES-115.5/99-W1
			508	508	3.90	4.55	1.08	5.79	6.42	3.06	5.13	1.97	1.18	.67	622.16			
127	5		35	35	120	142	28	180	184	92,1	152,4	50	30	17	360,5	M16x55	5/8-11 UNC x 2-1/4	BFX-311-ES-142/120-W1
			508	508	4.72	5.59	1.10	7.09	7.24	3.63	6.00	1.97	1.18	.67	793.10			

Materials / Ordering Options / Examples

- * SAE Single-Part Flange (without O-ring) made of Steel S355J0 or equivalent, blank (oiled)
- * SAE Single-Part Flange (without O-ring) made of Stainless Steel V4A – 1.4404 (on request)

BFX-...-ES--**/W1**
BFX-...-ES--**/W5**

- * Kit including Metric bolts 8.8, spring rings, O-ring made of NBR (Buna-N®)
- * Kit including Metric bolts 8.8, spring rings, O-ring made of FKM/FPM (Viton®)
- * Kit including Metric bolts 10.9, spring rings, O-ring made of NBR (Buna-N®)
- * Kit including UNC bolts (Grade 8), spring rings, O-ring made of NBR (Buna-N®)

BFX-...-ES--**/W46-K**
BFX-...-ES--**/V-W46-K**
BFX-...-ES--**/MH-W1-K**
BFX-...-ES--**/U-W1-K**

Please always indicate ØB / ØA.

¹ The maximum working pressure PN (bar/PSI) applies only to the flange itself and depends on the bolts used (Grade 8.8 / 10.9). The actual maximum working pressure depends on the thickness and the quality of the tube used.

³ Alternative options shown in brackets are available on request.

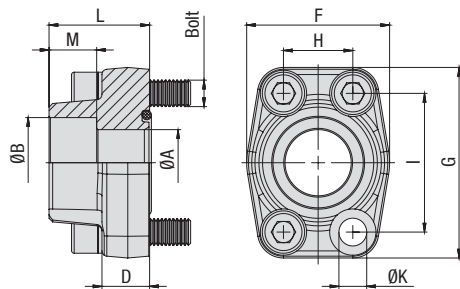

SAE Single-Part Socket-Weld Flange
 Type BFX-ES • 6000 PSI Series

6000 PSI High Pressure Series (based on ISO 6162-2:2002)

Nominal Size	DN	(in)	PN ¹ (bar/PSI)		Dimensions (mm/in)										Weight (kg/lbs) Ca. per 100	for Bolts		Ordering Codes
			8.8	10.9 (MH)	ØA	ØB	D	F	G	H	I	L	M	ØK		Metric	UNC	
13	1/2	350	420	13	21,6	16,5	47	57	18,2	40,5	36	18	8,7	28,0	M8x30	5/16-18 UNC x 1-1/4	BFX-601-ES-21.6/13-W1	
		5075	6090	.51	.85	.65	1.85	2.24	.72	1.59	1.42	.71	.34	61.60				
13	1/2	350	420	13	17,5	16,5	47	57	18,2	40,5	36	18	8,7	28,8	M8x30	5/16-18 UNC x 1-1/4	BFX-601-ES-17.5/13-W1	
		5075	6090	.51	.69	.65	1.85	2.24	.72	1.59	1.42	.71	.34	63.36				
13	1/2	350	420	13	20,3	16,5	47	57	18,2	40,5	36	18	8,7	27,3	M8x30	5/16-18 UNC x 1-1/4	BFX-601-ES-20.3/13-W1	
		5075	6090	.51	.80	.65	1.85	2.24	.72	1.59	1.42	.71	.34	60.06				
19	3/4	350	420	19	27,2	19,5	54	72	23,8	50,8	36	20	10,5	51,9	M10x35	3/8-16 UNC x 1-1/2	BFX-602-ES-27.2/19-W1	
		5075	6090	.75	1.07	.77	2.13	2.83	.94	2.00	1.42	.79	.41	114.18				
19	3/4	350	420	19	25,3	19,5	54	72	23,8	50,8	36	20	10,5	53,8	M10x35	3/8-16 UNC x 1-1/2	BFX-602-ES-25.3/19-W1	
		5075	6090	.75	1.00	.77	2.13	2.83	.94	2.00	1.42	.79	.41	118.36				
25	1	350	420	25	34	24,5	68	82	27,8	57,2	44	22	13	73,8	M12x45	7/16-14 UNC x 1-3/4	BFX-603-ES-34/25-W1 ²	
		5075	6090	.98	1.34	.96	2.68	3.23	1.09	2.25	1.73	.87	.51	162.36				
25	1	350	420	25	30,3	24,5	68	82	27,8	57,2	44	22	13	81,0	M12x45	7/16-14 UNC x 1-3/4	BFX-603-ES-30.3/25-W1 ²	
		5075	6090	.98	1.19	.96	2.68	3.23	1.09	2.25	1.73	.87	.51	178.20				
32	1-1/4	350	420	32	42,8	27,5	79	95	31,8	66,6	44	22	13,5	115,7	M12x45	1/2-13 UNC x 1-3/4	BFX-604-ES-42.8/32-W1	
		5075	6090	1.26	1.69	1.08	3.11	3.74	1.25	2.62	1.73	.87	.53	254.54				
32	1-1/4	350	420	32	42,8	27,5	79	95	31,8	66,6	44	22	15	110,3	M14x45		BFX-604-ES-42.8/32-M14-W1	
		5075	6090	1.26	1.69	1.08	3.11	3.74	1.25	2.62	1.73	.87	.59	242.66				
32	1-1/4	350	420	32	38,3	27,5	79	95	31,8	66,6	44	22	13,5	118,3	M12x45	1/2-13 UNC x 1-3/4	BFX-604-ES-38.3/32-W1	
		5075	6090	1.26	1.51	1.08	3.11	3.74	1.25	2.62	1.73	.87	.53	260.26				
32	1-1/4	350	420	32	38,3	27,5	79	95	31,8	66,6	44	22	15	125,6	M14x45		BFX-604-ES-38.3/32-M14-W1	
		5075	6090	1.26	1.51	1.08	3.11	3.74	1.25	2.62	1.73	.87	.59	276.32				
38	1-1/2	350	420	38	48,6	31	88	108	36,5	79,3	51	24	17	183,5	M16x55	5/8-11 UNC x 2-1/4	BFX-605-ES-48.6/38-W1	
		5075	6090	1.50	1.91	1.22	3.46	4.25	1.44	3.12	2.01	.94	.67	403.70				
38	1-1/2	350	420	38	50,5	31	88	108	36,5	79,3	51	24	17	184,7	M16x55	5/8-11 UNC x 2-1/4	BFX-605-ES-50.5/38-W1	
		5075	6090	1.50	1.99	1.22	3.46	4.25	1.44	3.12	2.01	.94	.67	406.34				
51	2	350	420	51	61	37	118	137	44,5	96,8	65	24	21	329,2	M20x70	3/4-10 UNC x 2-3/4	BFX-606-ES-61/51-W1	
		5075	6090	2.01	2.40	1.46	4.65	5.39	1.75	3.81	2.56	.94	.83	724.24				
64	2-1/2	350	420	63	76,6	45	152	180	58,7	123,8	80	32	26	849,6	M24x80		BFX-607-ES-76.6/63-W1	
		5075	6090	2.48	3.02	1.77	5.98	7.09	2.31	4.87	3.15	1.26	1.02	1869.12				
76	3	350	420	73	90,5	55	178	208	71,4	152,4	90	30	33	1110,1	M30x100		BFX-608-ES-90.5/73-W1	
		5075	6090	2.87	3.56	2.17	7.01	8.19	2.81	6.00	3.54	1.18	1.30	2442.22				

¹ The maximum working pressure PN (bar/PSI) applies only to the flange itself and depends on the bolts used (Grade 8.8 / 10.9). The actual maximum working pressure depends on the thickness and the quality of the tube used.

² For UNC threaded bolts, use hexagon head bolts only. Please note that these do not belong to our product range.

Materials / Ordering Options / Examples

- * SAE Single-Part Flange (without O-ring) made of Steel S355J0 or equivalent, blank (oiled) BFX-...-ES-*/**-W1
- * SAE Single-Part Flange (without O-ring) made of Stainless Steel V4A – 1.4404 (on request) BFX-...-ES-*/**-W5
- * Kit including Metric bolts 8.8, spring rings, O-ring made of NBR (Buna-N®) BFX-...-ES-*/**-W46-K
- * Kit including Metric bolts 8.8, spring rings, O-ring made of FKM/FPM (Viton®) BFX-...-ES-*/**-V-W46-K
- * Kit including Metric bolts 10.9, spring rings, O-ring made of NBR (Buna-N®) BFX-...-ES-*/**-MH-W1-K
- * Kit including UNC bolts (Grade 8), spring rings, O-ring made of NBR (Buna-N®) BFX-...-ES-*/**-U-W1-K

Please always indicate ØB / ØA.



**SAE Single-Part Socket-Weld Counterflange
Type BAS-ES • 3000 PSI Series**

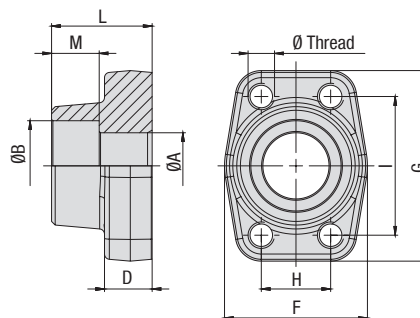

3000 PSI Standard Pressure Series (based on ISO 6162-1:2002)

Nominal Size	DN	(in)	PN ¹ (bar/PSI)		Dimensions (mm/in)								Weight (kg/lbs) ca.	Ø Thread		Ordering Codes	
			8.8	10.9 (MH)	ØA	ØB	D	F	G	H	I	L		M	per 100		Metric ³
13	1/2		350	350	13	21,6	16	47	57	17,5	38,1	36	18	29,4	M8	5/16-18 UNC	BAS-301-ES-21.6/13-W1
			5075	5075	.51	.85	.63	1.85	2.24	.69	1.50	1.42	.71	64.68			
13	1/2		350	350	13	17,5	16	47	57	17,5	38,1	36	18	30,3	M8	5/16-18 UNC	BAS-301-ES-17.5/13-W1
			5075	5075	.51	.69	.63	1.85	2.24	.69	1.50	1.42	.71	66.66			
13	1/2		350	350	13	20,3	16	47	57	17,5	38,1	36	18	30,2	M8	5/16-18 UNC	BAS-301-ES-20.3/13-W1
			5075	5075	.51	.80	.63	1.85	2.24	.69	1.50	1.42	.71	66.44			
19	3/4		350	350	19	27,2	18	50	67	22,3	47,6	36	18	40,1	M10	3/8-16 UNC	BAS-302-ES-27.2/19-W1
			5075	5075	.75	1.07	.71	1.97	2.64	.88	1.87	1.42	.71	88.22			
19	3/4		350	350	19	25,3	18	50	67	22,3	47,6	36	18	41,9	M10	3/8-16 UNC	BAS-302-ES-25.3/19-W1
			5075	5075	.75	1.00	.71	1.97	2.64	.88	1.87	1.42	.71	92.18			
25	1		250	315	25	34	18	54	72	26,2	52,4	38	18	46,4	M10	3/8-16 UNC	BAS-303-ES-34/25-W1
			3625	4568	.98	1.34	.71	2.13	2.83	1.03	2.06	1.50	.71	102.08			
25	1		250	315	25	30,3	18	54	72	26,2	52,4	38	18	50,0	M10	3/8-16 UNC	BAS-303-ES-30.3/25-W1
			3625	4568	.98	1.19	.71	2.13	2.83	1.03	2.06	1.50	.71	110.00			
32	1-1/4		200	250	32	42,8	21	68	82	30,2	58,7	41	20	68,0	M10 (M12)	7/16-14 UNC	BAS-304-ES-42.8/32-W1
			2900	3625	1.26	1.69	.83	2.68	3.23	1.19	2.31	1.61	.79	149.60			
32	1-1/4		200	250	32	38,3	21	68	82	30,2	58,7	41	20	72,0	M10 (M12)	7/16-14 UNC	BAS-304-ES-38.3/32-W1
			2900	3625	1.26	1.51	.83	2.68	3.23	1.19	2.31	1.61	.79	158.40			
38	1-1/2		200	200	38	48,6	25	79	96	35,7	69,9	44	22	107,3	M12 (M14)	1/2-13 UNC	BAS-305-ES-48.6/38-W1
			2900	2900	1.50	1.91	.98	3.11	3.78	1.41	2.75	1.73	.87	236.06			
38	1-1/2		200	200	38	50,5	25	79	96	35,7	69,9	44	22	105,7	M12 (M14)	1/2-13 UNC	BAS-305-ES-50.5/38-W1
			2900	2900	1.50	1.99	.98	3.11	3.78	1.41	2.75	1.73	.87	232.54			
51	2		160	200	51	61	25,5	88	102	42,9	77,8	45	24	126,0	M12 (M14)	1/2-13 UNC	BAS-306-ES-61/51-W1
			2320	2900	2.01	2.40	1.00	3.46	4.02	1.69	3.06	1.77	.94	277.20			
64	2-1/2		100	160	63	76,6	26	101	115	50,8	88,9	50	28	145,0	M12 (M14)	1/2-13 UNC	BAS-307-ES-76.6/63-W1
			1450	2320	2.48	3.02	1.02	3.98	4.53	2.00	3.50	1.97	1.10	319.00			
76	3		100	100	73	90,5	27,5	127	137	61,9	106,4	50	28	217,7	M16	5/8-11 UNC	BAS-308-ES-90.5/73-W1
			1450	1450	2.87	3.56	1.08	5.00	5.39	2.44	4.19	1.97	1.10	478.94			
89	3-1/2		35	35	89	103	27,5	138	155	69,9	120,7	50	30	263,8	M16	5/8-11 UNC	BAS-309-ES-103/89-W1
			508	508	3.50	4.06	1.08	5.43	6.10	2.75	4.75	1.97	1.18	580.36			
102	4		35	35	99	115,5	27,5	147	163	77,8	130,2	50	30	295,1	M16	5/8-11 UNC	BAS-310-ES-115.5/99-W1
			508	508	3.90	4.55	1.08	5.79	6.42	3.06	5.13	1.97	1.18	649.22			
127	5		35	35	120	142	28	180	184	92,1	152,4	50	30	390,6	M16	5/8-11 UNC	BAS-311-ES-142/120-W1
			508	508	4.72	5.59	1.10	7.09	7.24	3.63	6.00	1.97	1.18	859.32			

Materials / Ordering Options / Examples

- * SAE Single-Part Counterflange made of Steel S355J0 or equivalent, blank (oiled) with Metric tapped holes **BAS-...-ES-**-**-W1**
- * SAE Single-Part Counterflange made of Stainless Steel V4A – 1.4404 (on request) with Metric tapped holes **BAS-...-ES-**-**-W5**
- * SAE Single-Part Counterflange made of Steel S355J0 or equivalent, blank (oiled) with size of Metric tapped holes deviating from the standard (e.g. M14) **BAS-...-ES-**-**-M14-W1**
- * SAE Single-Part Counterflange made of Steel S355J0 or equivalent, blank (oiled) with UNC tapped holes **BAS-...-ES-**-**-U-W1**

Please always indicate ØB / ØA.

¹ The maximum working pressure PN (bar/PSI) applies only to the flange itself and depends on the bolts used (Grade 8.8 / 10.9). The actual maximum working pressure depends on the thickness and the quality of the tube used.

³ Alternative options shown in brackets are available on request.

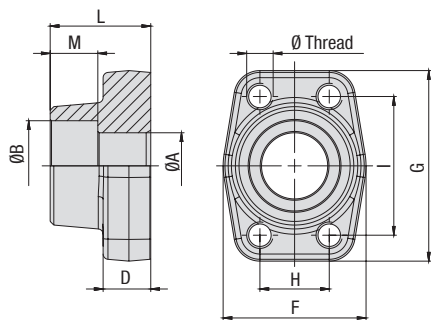

 SAE Single-Part Socket-Weld Counterflange
 Type BAS-ES - 6000 PSI Series

6000 PSI High Pressure Series (based on ISO 6162-2:2002)

Nominal Size	PN ¹ (bar/PSI)	Dimensions (mm/in)											Weight (kg/lbs) ca.	Ø Thread		Ordering Codes
		8.8	10.9 (MH)	ØA	ØB	D	F	G	H	I	L	M		per 100	Metric	
13	1/2	350	420	13	21,6	16,5	47	57	18,2	40,5	36	18	28,3	M8	5/16-18 UNC	BAS-601-ES-21.6/13-W1
		5075	6090	.51	.85	.65	1.85	2.24	.72	1.59	1.42	.71	62.26			
13	1/2	350	420	13	17,5	16,5	47	57	18,2	40,5	36	18	30,0	M8	5/16-18 UNC	BAS-601-ES-17.5/13-W1
		5075	6090	.51	.69	.65	1.85	2.24	.72	1.59	1.42	.71	66.00			
13	1/2	350	420	13	20,3	16,5	47	57	18,2	40,5	36	18	29,0	M8	5/16-18 UNC	BAS-601-ES-20.3/13-W1
		5075	6090	.51	.80	.65	1.85	2.24	.72	1.59	1.42	.71	63.80			
19	3/4	350	420	19	27,2	19,5	54	72	23,8	50,8	36	20	51,2	M10	3/8-16 UNC	BAS-602-ES-27.2/19-W1
		5075	6090	.75	1.07	.77	2.13	2.83	.94	2.00	1.42	.79	112.64			
19	3/4	350	420	19	25,3	19,5	54	72	23,8	50,8	36	20	52,5	M10	3/8-16 UNC	BAS-602-ES-25.3/19-W1
		5075	6090	.75	1.00	.77	2.13	2.83	.94	2.00	1.42	.79	115.50			
25	1	350	420	25	34	24,5	68	82	27,8	57,2	44	22	77,1	M12	7/16-14 UNC	BAS-603-ES-34/25-W1
		5075	6090	.98	1.34	.96	2.68	3.23	1.09	2.25	1.73	.87	169.62			
25	1	350	420	25	30,3	24,5	68	82	27,8	57,2	44	22	91,1	M12	7/16-14 UNC	BAS-603-ES-30.3/25-W1
		5075	6090	.98	1.19	.96	2.68	3.23	1.09	2.25	1.73	.87	200.42			
32	1-1/4	350	420	32	42,8	27,5	79	95	31,8	66,6	44	22	117,1	M12	1/2-13 UNC	BAS-604-ES-42.8/32-W1
		5075	6090	1.26	1.69	1.08	3.11	3.74	1.25	2.62	1.73	.87	257.62			
32	1-1/4	350	420	32	42,8	27,5	79	95	31,8	66,6	44	22	116,7	M14		BAS-604-ES-42.8/32-M14-W1
		5075	6090	1.26	1.69	1.08	3.11	3.74	1.25	2.62	1.73	.87	256.74			
32	1-1/4	350	420	32	38,3	27,5	79	95	31,8	66,6	44	22	126,2	M12	1/2-13 UNC	BAS-604-ES-38.3/32-W1
		5075	6090	1.26	1.51	1.08	3.11	3.74	1.25	2.62	1.73	.87	277.64			
32	1-1/4	350	420	32	38,3	27,5	79	95	31,8	66,6	44	22	123,9	M14		BAS-604-ES-38.3/32-M14-W1
		5075	6090	1.26	1.51	1.08	3.11	3.74	1.25	2.62	1.73	.87	272.58			
38	1-1/2	350	420	38	48,6	31	88	108	36,5	79,3	51	24	184,2	M16	5/8-11 UNC	BAS-605-ES-48.6/38-W1
		5075	6090	1.50	1.91	1.22	3.46	4.25	1.44	3.12	2.01	.94	405.24			
38	1-1/2	350	420	38	50,5	31	88	108	36,5	79,3	51	24	191,4	M16	5/8-11 UNC	BAS-605-ES-50.5/38-W1
		5075	6090	1.50	1.99	1.22	3.46	4.25	1.44	3.12	2.01	.94	421.08			
51	2	350	420	51	61	37	118	137	44,5	96,8	65	24	356,9	M20	3/4-10 UNC	BAS-606-ES-61/51-W1
		5075	6090	2.01	2.40	1.46	4.65	5.39	1.75	3.81	2.56	.94	785.18			
64	2-1/2	350	420	63	76,6	45	152	180	58,7	123,8	80	32	740,2	M24		BAS-607-ES-76.6/63-W1
		5075	6090	2.48	3.02	1.77	5.98	7.09	2.31	4.87	3.15	1.26	1628.44			
76	3	350	420	73	90,5	55	178	208	71,4	152,4	90	30	1304,8	M30		BAS-608-ES-90.5/73-W1
		5075	6090	2.87	3.56	2.17	7.01	8.19	2.81	6.00	3.54	1.18	2870.56			

¹ The maximum working pressure PN (bar/PSI) applies only to the flange itself and depends on the bolts used (Grade 8.8 / 10.9). The actual maximum working pressure depends on the thickness and the quality of the tube used.

Materials / Ordering Options / Examples

- * SAE Single-Part Counterflange made of Steel S355J0 or equivalent, blank (oiled) with Metric tapped holes BAS-...-ES-*/**-W1
- * SAE Single-Part Counterflange made of Stainless Steel V4A – 1.4404 (on request) with Metric tapped holes BAS-...-ES-*/**-W5
- * SAE Single-Part Counterflange made of Steel S355J0 or equivalent, blank (oiled) with size of Metric tapped holes deviating from the standard (e.g. M14) BAS-...-ES-*/**-M14-W1
- * SAE Single-Part Counterflange made of Steel S355J0 or equivalent, blank (oiled) with UNC tapped holes BAS-...-ES-*/**-U-W1

Please always indicate ØB / ØA.



SAE Single-Part Socket-Weld Flange (Flat Style)
Type BFX-FL-ES ▪ 3000 PSI Series

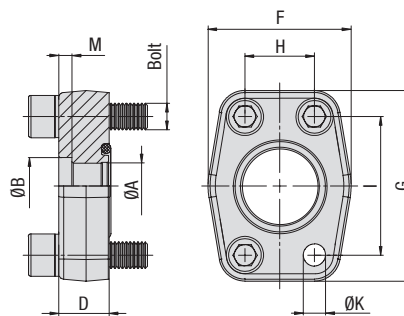

3000 PSI Standard Pressure Series (based on ISO 6162-1:2002)

Nominal Size	DN	(in)	PN ¹ (bar/PSI)		Dimensions (mm/in)								Weight (kg/lbs) ca. per 100	for Bolts Metric	Ordering Codes	
			8.8	10.9 (MH)	ØA	ØB	D	F	G	H	I	M				ØK
13	1/2		40	40	15	22,5	10	47	57	17,5	38,1	3	8,7	12,8	M8x25	BFX-FL-301-ES-22.5/15-W1
			580	580	.59	.89	.39	1.85	2.24	.69	1.50	.12	.34	28.16		
19	3/4		40	40	20	28,5	12	50	67	22,3	47,6	4	10,5	18,7	M10x30	BFX-FL-302-ES-28.5/20-W1
			580	580	.79	1.12	.47	1.97	2.64	.88	1.87	.16	.41	41.14		
25	1		40	40	29	35,5	12	54	72	26,2	52,4	4	10,5	19,7	M10x30	BFX-FL-303-ES-35.5/29-W1
			580	580	1.14	1.40	.47	2.13	2.83	1.03	2.06	.16	.41	43.34		
32	1-1/4		40	40	34	42,5	12	68	82	30,2	58,7	4	11,5	26,9	M10x30	BFX-FL-304-ES-42.5/34-W1
			580	580	1.34	1.67	.47	2.68	3.23	1.19	2.31	.16	.45	59.18		
38	1-1/2		40	40	42	49	15	79	96	35,7	69,9	4	13,5	45,7	M12x35	BFX-FL-305-ES-49/42-W1
			580	580	1.65	1.93	.59	3.11	3.78	1.41	2.75	.16	.53	100.54		
51	2		40	40	53	61	15	88	102	42,9	77,8	4	13,5	55,5	M12x35	BFX-FL-306-ES-61/53-W1
			580	580	2.09	2.40	.59	3.46	4.02	1.69	3.06	.16	.53	122.10		
64	2-1/2		40	40	64	77	15	101	115	50,8	88,9	4	13,5	68,0	M12x35	BFX-FL-307-ES-77/64-W1
			580	580	2.52	3.03	.59	3.98	4.53	2.00	3.50	.16	.53	149.60		
76	3		40	40	80	90	20	127	137	61,9	106,4	5	17	125,8	M16x50	BFX-FL-308-ES-90/80-W1
			580	580	3.15	3.54	.79	5.00	5.39	2.44	4.19	.20	.67	276.76		
89	3-1/2		35	35	93	103	20	138	155	69,9	120,7	5	17	143,5	M16x50	BFX-FL-309-ES-103/93-W1
			508	508	3.66	4.06	.79	5.43	6.10	2.75	4.75	.20	.67	315.70		
102	4		35	35	105	116	25	147	163	77,8	130,2	6	17	194,6	M16x50	BFX-FL-310-ES-116/105-W1
			508	508	4.13	4.57	.98	5.79	6.42	3.06	5.13	.24	.67	428.12		
125	5		35	35	126	141	28	170	190	92,1	152,4	8	17	287,8	M16x50	BFX-FL-311-ES-141/126-W1
			508	508	4.96	5.55	1.10	6.69	7.48	3.63	6.00	.31	.67	633.16		

Materials / Ordering Options / Examples

* SAE Single-Part Flange (without O-ring) made of Steel S355J0 or equivalent, blank (oiled)

BFX-FL-...-ES-*//W1**

* Kit including Metric bolts 8.8, spring rings, O-ring made of NBR (Buna-N®)

BFX-FL-...-ES-*//W46-K**

* Kit including Metric bolts 8.8, spring rings, O-ring made of FKM/FPM (Viton®)

BFX-FL-...-ES-*//V-W46-K**

* Kit including Metric bolts 10.9, spring rings, O-ring made of NBR (Buna-N®)

BFX-FL-...-ES-*//MH-W1-K**

Please always indicate ØB / ØA.

¹ The maximum working pressure PN (bar/PSI) applies only to the flange itself. The actual maximum working pressure depends on the thickness and the quality of the tube used.



SAE Single-Part Socket-Weld Counterflange (Flat Style)
Type BAS-FL-ES ▪ 3000 PSI Series

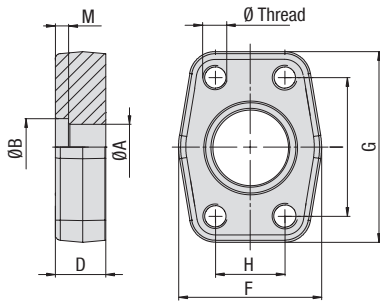

3000 PSI Standard Pressure Series (based on ISO 6162-1:2002)

Nominal Size	PN ¹ (bar/PSI)	Dimensions (mm/in)										Weight (^{kg} /lbs) ca. per 100	Ø Thread Metric	Ordering Codes
		DN	(in)	8.8	10.9 (MH)	ØA	ØB	D	F	G	H			
13	1/2	40	40	15	22,5	10	47	57	17,5	38,1	3	14,4	M8	BAS-FL-301-ES-22.5/15-W1
		580	580	.59	.89	.39	1.85	2.24	.69	1.50	.12	31.68		
19	3/4	40	40	20	28,5	12	50	67	22,3	47,6	4	20,5	M10	BAS-FL-302-ES-28.5/20-W1
		580	580	.79	1.12	.47	1.97	2.64	.88	1.87	.16	45.10		
25	1	40	40	29	35,5	12	54	72	26,2	52,4	4	21,6	M10	BAS-FL-303-ES-35.5/29-W1
		580	580	1.14	1.40	.47	2.13	2.83	1.03	2.06	.16	47.52		
32	1-1/4	40	40	34	42,5	12	68	82	30,2	58,7	4	29,5	M10	BAS-FL-304-ES-42.5/34-W1
		580	580	1.34	1.67	.47	2.68	3.23	1.19	2.31	.16	64.90		
38	1-1/2	40	40	42	49	15	79	96	35,7	69,9	4	48,6	M12	BAS-FL-305-ES-49/42-W1
		580	580	1.65	1.93	.59	3.11	3.78	1.41	2.75	.16	106.92		
51	2	40	40	53	61	15	88	102	42,9	77,8	4	59,8	M12	BAS-FL-306-ES-61/53-W1
		580	580	2.09	2.40	.59	3.46	4.02	1.69	3.06	.16	131.56		
64	2-1/2	40	40	64	77	15	101	115	50,8	88,9	4	72,4	M12	BAS-FL-307-ES-77/64-W1
		580	580	2.52	3.03	.59	3.98	4.53	2.00	3.50	.16	159.28		
76	3	40	40	80	90	20	127	137	61,9	106,4	5	132,9	M16	BAS-FL-308-ES-90/80-W1
		580	580	3.15	3.54	.79	5.00	5.39	2.44	4.19	.20	292.38		
89	3-1/2	35	35	93	103	20	138	155	69,9	120,7	5	151,6	M16	BAS-FL-309-ES-103/93-W1
		508	508	3.66	4.06	.79	5.43	6.10	2.75	4.75	.20	333.52		
102	4	35	35	105	116	25	147	163	77,8	130,2	6	203,9	M16	BAS-FL-310-ES-116/105-W1
		508	508	4.13	4.57	.98	5.79	6.42	3.06	5.13	.24	448.58		
125	5	35	35	126	141	28	170	190	92,1	152,4	8	293,0	M16	BAS-FL-311-ES-141/126-W1
		508	508	4.96	5.55	1.10	6.69	7.48	3.63	6.00	.31	644.60		

¹ The maximum working pressure PN (bar/PSI) applies only to the flange itself. The actual maximum working pressure depends on the thickness and the quality of the tube used.

Materials / Ordering Options / Examples

* SAE Single-Part Counterflange made of Steel S355J0 or equivalent, blank (oiled) with Metric tapped holes

BAS-FL-...-ES-**-**/**-W1

Please always indicate ØB / ØA.



**SAE Single-Part Flange with Male Metric Thread and 24° Conical Bore (Shape W acc. to DIN 3861)
Type BFX-L/S • 3000 PSI Series**

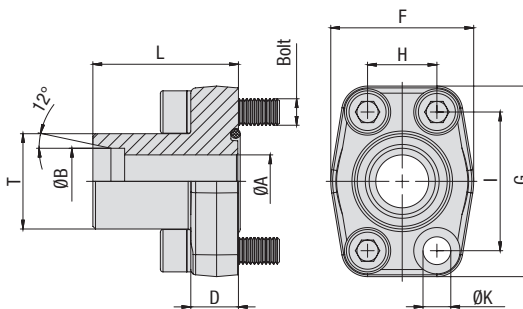

3000 PSI Standard Pressure Series (based on ISO 6162-1:2002)

Nominal Size	DN	(in)	PN ¹ (bar/PSI)		Dimensions (mm/in)		Series	D	F	G	H	I	L	T (Metric)	ØK ³	Weight		for Bolts Metric ³	Ordering Codes
			8.8	10.9 (MH)	ØA	ØB										(kg/lbs) Ca.	per 100		
13	1/2		315	315	11	15	L	16	43	57	17,5	38,1	47	22x1,5	8,7	26,2	M8x30	BFX-301-15L-W66	
			4568	4568	.43	.59		.63	1.69	2.24	.69	1.50	1.85						.34
19	3/4		350	350	16	20	S	18	50	67	22,3	47,6	52	30x2	10,5	40,7	M10x35	BFX-302-20S-W66	
			5075	5075	.63	.79		.71	1.97	2.64	.88	1.87	2.05						.41
19	3/4		160	160	19	22	L	18	50	67	22,3	47,6	52	30x2	10,5	42,4	M10x35	BFX-302-22L-W66	
			2320	2320	.75	.87		.71	1.97	2.64	.88	1.87	2.05						.41
25	1		250	315	16	20	S	18	54	72	26,2	52,4	55	30x2	10,5	52,5	M10x35	BFX-303-20S-W66	
			3625	4568	.63	.79		.71	2.13	2.83	1.03	2.06	2.17						.41
25	1		250	315	20	25	S	18	54	72	26,2	52,4	55	36x2	10,5	56,1	M10x35	BFX-303-25S-W66	
			3625	4568	.79	.98		.71	2.13	2.83	1.03	2.06	2.17						.41
25	1		160	160	23	28	L	18	54	72	26,2	52,4	55	36x2	10,5	52,5	M10x35	BFX-303-28L-W66	
			2320	2320	.91	1.10		.71	2.13	2.83	1.03	2.06	2.17						.41
32	1-1/4		200	250	20	25	S	21	68	82	30,2	58,7	60	36x2	11,5 (13,5)	81,0	M10x40 (M12x40)	BFX-304-25S-W66	
			2900	3625	.79	.98		.83	2.68	3.23	1.19	2.31	2.36						.45 (.53)
32	1-1/4		200	250	25	30	S	21	68	82	30,2	58,7	60	42x2	11,5 (13,5)	69,7	M10x40 (M12x40)	BFX-304-30S-W66	
			2900	3625	.98	1.18		.83	2.68	3.23	1.19	2.31	2.36						.45 (.53)
32	1-1/4		160	160	30	35	L	21	68	82	30,2	58,7	60	45x2	11,5 (13,5)	80,1	M10x40 (M12x40)	BFX-304-35L-W66	
			2320	2320	1.18	1.38		.83	2.68	3.23	1.19	2.31	2.36						.45 (.53)
38	1-1/2		200	200	32	38	S	25	74	96	35,7	69,9	70	52x2	13,5 (14,5)	130,5	M12x45 (M14x45)	BFX-305-38S-W66	
			2900	2900	1.26	1.50		.98	2.91	3.78	1.41	2.75	2.76						.53 (.57)
38	1-1/2		160	160	36	42	L	25	74	96	35,7	69,9	70	52x2	13,5 (14,5)	121,2	M12x45 (M14x45)	BFX-305-42L-W66	
			2320	2320	1.42	1.65		.98	2.91	3.78	1.41	2.75	2.76						.53 (.57)

Materials / Ordering Options / Examples

* SAE Single-Part Flange (without O-ring) made of Steel S355J0 / C45 or equivalent, zinc-plated and thick-film-passivated

BFX-...-...-W66

* SAE Single-Part Flange (without O-ring) made of Stainless Steel V4A – 1.4404 (on request)

BFX-...-...-W5

* Kit including Metric bolts 8.8, spring rings, O-ring made of NBR (Buna-N®)

BFX-...-...-W66-K

* Kit including Metric bolts 8.8, spring rings, O-ring made of FKM/FPM (Viton®)

BFX-...-...-V-W66-K

* Kit including Metric bolts 10.9, spring rings, O-ring made of NBR (Buna-N®)

BFX-...-...-MH-W129-K

Please always indicate ØB and Series.

¹ The maximum working pressure PN (bar/PSI) applies only to the flange itself and depends on the bolts used (Grade 8.8 / 10.9). The actual maximum working pressure depends on the thickness and the quality of the tube used.

³ Alternative options shown in brackets are available on request.



SAE Single-Part Flange with Male Metric Thread and 24° Conical Bore (Shape W acc. to DIN 3861) Type BFX-L/S - 6000 PSI Series

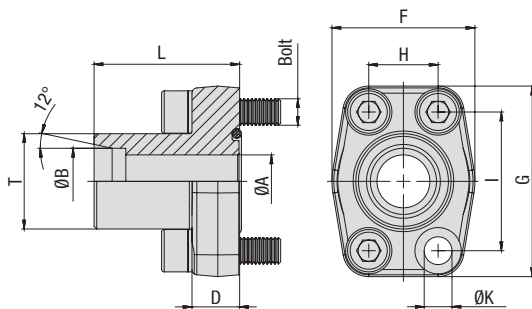

6000 PSI High Pressure Series (based on ISO 6162-2:2002)

Nominal Size	DN	(in)	PN ¹ (bar/PSI)		Dimensions (mm/in)		Series	D	F	G	H	I	L	T (Metric)	ØK	Weight (kg/lbs) Ca. per 100	for Bolts Metric	Ordering Codes
			8.8	10.9 (MH)	ØA	ØB												
13	1/2		350	420	12	16	S	16	43	57	18,2	40,5	47	24x1,5	8,7	27,3	M8x30	BFX-601-16S-W66
			5075	6090	.47	.63		.63	1.69	2.24	.72	1.59	1.85		.34	60.06		
19	3/4		350	420	12	16	S	18	54	72	23,8	50,8	54	24x1,5	10,5	53,2	M10x35	BFX-602-16S-W66
			5075	6090	.47	.63		.71	2.13	2.83	.94	2.00	2.13		.41	117.04		
19	3/4		350	400	16	20	S	18	54	72	23,8	50,8	54	30x2	10,5	52,7	M10x35	BFX-602-20S-W66
			5075	5800	.63	.79		.71	2.13	2.83	.94	2.00	2.13		.41	115.94		
19	3/4		350	400	18	25	S	18	54	72	23,8	50,8	54	36x2	10,5	56,8	M10x35	BFX-602-25S-W66
			5075	5800	.71	.98		.71	2.13	2.83	.94	2.00	2.13		.41	124.96		
25	1		350	400	16	20	S	21	68	82	27,8	57,2	60	30x2	13	76,1	M12x40	BFX-603-20S-W66
			5075	5800	.63	.79		.83	2.68	3.23	1.09	2.25	2.36		.51	167.42		
25	1		350	400	18	25	S	21	68	82	27,8	57,2	60	36x2	13	79,0	M12x40	BFX-603-25S-W66
			5075	5800	.71	.98		.83	2.68	3.23	1.09	2.25	2.36		.51	173.80		
25	1		350	400	25	30	S	21	68	82	27,8	57,2	60	42x2	13	82,4	M12x40	BFX-603-30S-W66
			5075	5800	.98	1.18		.83	2.68	3.23	1.09	2.25	2.36		.51	181.28		
32	1-1/4		350	400	25	30	S	24	75	95	31,8	66,6	68	42x2	13,5	118,2	M12x45	BFX-604-30S-W66
			5075	5800	.98	1.18		.94	2.95	3.74	1.25	2.62	2.68		.53	260.04		
32	1-1/4		350	400	25	30	S	24	75	95	31,8	66,6	68	42x2	15	117,4	M14x45	BFX-604-30S-M14-W66
			5075	5800	.98	1.18		.94	2.95	3.74	1.25	2.62	2.68		.59	258.28		
32	1-1/4		350	350	29	38	S	27	75	95	31,8	66,6	92	52x2	13,5	124,5	M12x45	BFX-604-38S-W66
			5075	5075	1.14	1.50		1.06	2.95	3.74	1.25	2.62	3.62		.53	273.90		
32	1-1/4		350	350	29	38	S	27	75	95	31,8	66,6	92	52x2	15	121,6	M14x45	BFX-604-38S-M14-W66
			5075	5075	1.14	1.50		1.06	2.95	3.74	1.25	2.62	3.62		.59	267.52		
38	1-1/2		350	350	32	38	S	27	84	108	36,5	79,3	72	52x2	17	170,7	M16x50	BFX-605-38S-W66
			5075	5075	1.26	1.50		1.06	3.31	4.25	1.44	3.12	2.83		.67	375.54		

¹ The maximum working pressure PN (bar/PSI) applies only to the flange itself and depends on the bolts used (Grade 8.8 / 10.9). The actual maximum working pressure depends on the thickness and the quality of the tube used.

Materials / Ordering Options / Examples

- * SAE Single-Part Flange (without O-ring) made of Steel S355J0 / C45 or equivalent, zinc-plated and thick-film-passivated **BFX-...-W66**
- * SAE Single-Part Flange (without O-ring) made of Stainless Steel V4A – 1.4404 (on request) **BFX-...-W5**
- * Kit including Metric bolts 8.8, spring rings, O-ring made of NBR (Buna-N®) **BFX-...-W66-K**
- * Kit including Metric bolts 8.8, spring rings, O-ring made of FKM/FPM (Viton®) **BFX-...-V-W66-K**
- * Kit including Metric bolts 10.9, spring rings, O-ring made of NBR (Buna-N®) **BFX-...-MH-W129-K**

Please always indicate ØB and Series.



**SAE Single-Part Flange with Male BSPP Thread and 60° Conical Bore (acc. to BS 5200)
Type BFX-B • 3000 PSI Series**

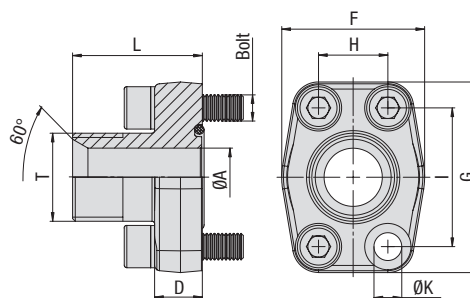

3000 PSI Standard Pressure Series (based on ISO 6162-1:2002)

Nominal Size	DN	(in)	PN ¹ (bar/PSI)		Dimensions (mm/in)								Weight (kg/lbs) Ca. per 100	for Bolts Metric ³	Ordering Codes	
			8.8	10.9 (MH)	ØA	D	F	G	H	I	L	T (BSPP)				ØK ³
13	1/2		350	350	10	16	43	57	17,5	38	37	3/8 (06)	8,7	22,6	M8x30	BFX-301-B06-W66
			5075	5075	.39	.63	1.69	2.24	.69	1.50	1.46	.34	49.72			
13	1/2		350	350	12	16	43	57	17,5	38	39	1/2	8,7	23,6	M8x30	BFX-301-B-W66
			5075	5075	.47	.63	1.69	2.24	.69	1.50	1.54	.34	51.92			
13	1/2		350	350	13	16	43	57	17,5	38	42	3/4 (12)	8,7	25,6	M8x30	BFX-301-B12-W66
			5075	5075	.51	.63	1.69	2.24	.69	1.50	1.65	.34	56.32			
19	3/4		350	350	12	18	50	67	22,3	47,6	42	1/2 (08)	10,5	37,3	M10x35	BFX-302-B08-W66
			5075	5075	.47	.71	1.97	2.64	.88	1.87	1.65	.41	82.06			
19	3/4		350	350	17	18	50	67	22,3	47,6	45	3/4	10,5	39,8	M10x35	BFX-302-B-W66
			5075	5075	.67	.71	1.97	2.64	.88	1.87	1.77	.41	87.56			
19	3/4		350	350	19	18	50	67	22,3	47,6	47	1 (16)	10,5	43,4	M10x35	BFX-302-B16-W66
			5075	5075	.75	.71	1.97	2.64	.88	1.87	1.85	.41	95.48			
25	1		250	315	17	18	54	72	26,2	52,4	47	3/4 (12)	10,5	46,0	M10x35	BFX-303-B12-W66
			3625	4568	.67	.71	2.13	2.83	1.03	2.06	1.85	.41	101.20			
25	1		250	315	22	18	54	72	26,2	52,4	49	1	10,5	47,3	M10x35	BFX-303-B-W66
			3625	4568	.87	.71	2.13	2.83	1.03	2.06	1.93	.41	104.06			
25	1		250	315	25	18	54	72	26,2	52,4	49	1-1/4 (20)	10,5	53,3	M10x35	BFX-303-B20-W66
			3625	4568	.98	.71	2.13	2.83	1.03	2.06	1.93	.41	117.26			
32	1-1/4		200	250	22	21	68	82	30,2	58,7	53	1 (16)	11,5 (13,5)	71,5	M10x40 (M12x40)	BFX-304-B16-W66
			2900	3625	.87	.83	2.68	3.23	1.19	2.31	2.09	.45 (.53)	157.30			
32	1-1/4		200	250	27	21	68	82	30,2	58,7	55	1-1/4	11,5 (13,5)	77,0	M10x40 (M12x40)	BFX-304-B-W66
			2900	3625	1.06	.83	2.68	3.23	1.19	2.31	2.17	.45 (.53)	169.40			
32	1-1/4		200	250	31	21	68	82	30,2	58,7	55	1-1/2 (24)	11,5 (13,5)	88,2	M10x40 (M12x40)	BFX-304-B24-W66
			2900	3625	1.22	.83	2.68	3.23	1.19	2.31	2.17	.45 (.53)	194.04			
38	1-1/2		200	200	27	24	74	96	35,7	69,9	59	1-1/4 (20)	13,5 (14,5)	78,6	M12x45 (M14x45)	BFX-305-B20-W66
			2900	2900	1.06	.94	2.91	3.78	1.41	2.75	2.32	.53 (.57)	172.92			
38	1-1/2		200	200	34	24	74	96	35,7	69,9	61	1-1/2	13,5 (14,5)	107,8	M12x45 (M14x45)	BFX-305-B-W66
			2900	2900	1.34	.94	2.91	3.78	1.41	2.75	2.40	.53 (.57)	237.16			
38	1-1/2		200	200	38	24	74	96	35,7	69,9	63	2 (32)	13,5 (14,5)	123,1	M12x45 (M14x45)	BFX-305-B32-W66
			2900	2900	1.50	.94	2.91	3.78	1.41	2.75	2.48	.53 (.57)	270.82			
51	2		160	200	34	25	88	102	42,9	77,8	69	1-1/2 (24)	13,5 (14,5)	154,9	M12x45 (M14x45)	BFX-306-B24-W66
			2320	2900	1.34	.98	3.46	4.02	1.69	3.06	2.72	.53 (.57)	340.78			
51	2		160	200	42	25	88	102	42,9	77,8	69	2	13,5 (14,5)	155,4	M12x45 (M14x45)	BFX-306-B-W66
			2320	2900	1.65	.98	3.46	4.02	1.69	3.06	2.72	.53 (.57)	341.88			

Materials / Ordering Options / Examples

- * SAE Single-Part Flange (without O-ring) made of Steel S355J0 / C45 or equivalent, zinc-plated and thick-film-passivated **BFX-...-B-W66**
- * SAE Single-Part Flange (without O-ring) made of Stainless Steel V4A – 1.4404 (on request) **BFX-...-B-W5**
- * Size of connection thread deviating from the standard (e.g. 1-1/4 BSPP) **BFX-...-B20-W66**
- * Kit including Metric bolts 8.8, spring rings, O-ring made of NBR (Buna-N®) **BFX-...-B-W66-K**
- * Kit including Metric bolts 8.8, spring rings, O-ring made of FKM/FPM (Viton®) **BFX-...-B-V-W66-K**
- * Kit including Metric bolts 10.9, spring rings, O-ring made of NBR (Buna-N®) **BFX-...-B-MH-W129-K**

¹ The maximum working pressure PN (bar/PSI) applies only to the flange itself and depends on the bolts used (Grade 8.8 / 10.9). The actual maximum working pressure depends on the thickness and the quality of the tube used.

³ Alternative options shown in brackets are available on request.

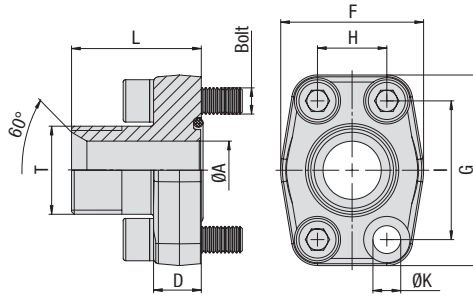

SAE Single-Part Flange with Male BSPP Thread and 60° Conical Bore (acc. to BS 5200)
 Type BFX-B • 6000 PSI Series

6000 PSI High Pressure Series (based on ISO 6162-2:2002)

Nominal Size	DN	(in)	PN ¹		Dimensions								Weight		for Bolts	Ordering Codes
			(bar/PSI)	(MH)	ØA	D	F	G	H	I	L	T (BSPP)	ØK	(kg/lbs) ca.		
13	1/2	350	420	10	16	43	57	18,2	40,5	38	3/8 (06)	8,7	21,7	M8x30	BFX-601-B06-W66	
		5075	6090	.39	.63	1.69	2.24	.72	1.59	1.50		.34	47.74			
13	1/2	350	420	12	16	43	57	18,2	40,5	40	1/2	8,7	23,7	M8x30	BFX-601-B-W66	
		5075	6090	.47	.63	1.69	2.24	.72	1.59	1.57		.34	52.14			
13	1/2	350	420	13	16	43	57	18,2	40,5	43	3/4 (12)	8,7	27,5	M8x30	BFX-601-B12-W66	
		5075	6090	.51	.63	1.69	2.24	.72	1.59	1.69		.34	60.50			
19	3/4	350	420	12	18	54	72	23,8	50,8	44	1/2 (08)	10,5	43,5	M10x35	BFX-602-B08-W66	
		5075	6090	.47	.71	2.13	2.83	.94	2.00	1.73		.41	95.70			
19	3/4	350	420	17	18	54	72	23,8	50,8	47	3/4	10,5	44,9	M10x35	BFX-602-B-W66	
		5075	6090	.67	.71	2.13	2.83	.94	2.00	1.85		.41	98.78			
19	3/4	350	420	19	18	54	72	23,8	50,8	49	1 (16)	10,5	50,9	M10x35	BFX-602-B16-W66	
		5075	6090	.75	.71	2.13	2.83	.94	2.00	1.93		.41	111.98			
25	1	350	420	17	21	68	82	27,8	57,2	54	3/4 (12)	13	68,7	M12x40	BFX-603-B12-W66	
		5075	6090	.67	.83	2.68	3.23	1.09	2.25	2.13		.51	151.14			
25	1	350	420	22	21	68	82	27,8	57,2	56	1	13	71,3	M12x40	BFX-603-B-W66	
		5075	6090	.87	.83	2.68	3.23	1.09	2.25	2.20		.51	156.86			
25	1	350	420	25	21	68	82	27,8	57,2	56	1-1/4 (20)	13	79,0	M12x40	BFX-603-B20-W66	
		5075	6090	.98	.83	2.68	3.23	1.09	2.25	2.20		.51	173.80			
32	1-1/4	350	420	22	24	75	95	31,8	66,6	61	1 (16)	13,5	116,7	M12x45	BFX-604-B16-W66	
		5075	6090	.87	.94	2.95	3.74	1.25	2.62	2.40		.53	256.74			
32	1-1/4	350	420	22	24	75	95	31,8	66,6	61	1 (16)	15	106,9	M14x45	BFX-604-B16-M14-W66	
		5075	6090	.87	.94	2.95	3.74	1.25	2.62	2.40		.59	235.18			
32	1-1/4	350	420	27	24	75	95	31,8	66,6	61	1-1/4	13,5	116,7	M12x45	BFX-604-B-W66	
		5075	6090	1.06	.94	2.95	3.74	1.25	2.62	2.40		.53	256.74			
32	1-1/4	350	420	27	24	75	95	31,8	66,6	61	1-1/4	15	110,3	M14x45	BFX-604-B-M14-W66	
		5075	6090	1.06	.94	2.95	3.74	1.25	2.62	2.40		.59	242.66			
32	1-1/4	350	420	31	24	75	95	31,8	66,6	63	1-1/2 (24)	13,5	106,9	M12x45	BFX-604-B24-W66	
		5075	6090	1.22	.94	2.95	3.74	1.25	2.62	2.48		.53	235.18			
32	1-1/4	350	420	31	24	75	95	31,8	66,6	63	1-1/2 (24)	15	114,5	M14x45	BFX-604-B24-M14-W66	
		5075	6090	1.22	.94	2.95	3.74	1.25	2.62	2.48		.59	251.90			
38	1-1/2	350	420	27	27	84	108	36,5	79,3	65	1-1/4	17	157,9	M16x50	BFX-605-B20-W66	
		5075	6090	1.06	1.06	3.31	4.25	1.44	3.12	2.56		.67	347.38			
38	1-1/2	350	420	32	27	84	108	36,5	79,3	67	1-1/2	17	156,5	M16x50	BFX-605-B-W66	
		5075	6090	1.26	1.06	3.31	4.25	1.44	3.12	2.64		.67	344.30			

¹ The maximum working pressure PN (bar/PSI) applies only to the flange itself and depends on the bolts used (Grade 8.8 / 10.9). The actual maximum working pressure depends on the thickness and the quality of the tube used.

Materials / Ordering Options / Examples

- * SAE Single-Part Flange (without O-ring) made of Steel S355J0 / C45 or equivalent, zinc-plated and thick-film-passivated BFX-...-B-W66
- * SAE Single-Part Flange (without O-ring) made of Stainless Steel V4A – 1.4404 (on request) BFX-...-B-W5
- * Size of connection thread deviating from the standard (e.g. 1-1/4 BSPP) BFX-...-B20-W66
- * Kit including Metric bolts 8.8, spring rings, O-ring made of NBR (Buna-N®) BFX-...-B-W66-K
- * Kit including Metric bolts 8.8, spring rings, O-ring made of FKM/FPM (Viton®) BFX-...-B-V-W66-K
- * Kit including Metric bolts 10.9, spring rings, O-ring made of NBR (Buna-N®) BFX-...-B-MH-W129-K



**SAE Single-Part Flange with Male UN/UNF Thread and 37° JIC Taper (acc. to ISO 8434-2 / SAE J514)
Type BFX-J • 3000 / 6000 PSI Series**

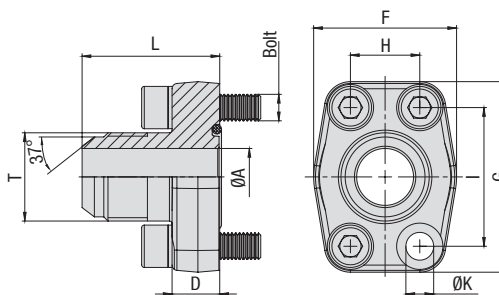

3000 PSI Standard Pressure Series (based on ISO 6162-1:2002)

Nominal Size	DN	(in)	PN ¹		Dimensions								T (UN/UNF)	ØK ³	Weight	for Bolts		Ordering Codes
			(bar/PSI)	10.9 (MH)	ØA	D	F	G	H	I	L	(^{kg/lbs}) ca.				Metric ³	UNC	
13	1/2		350	350	9,9	16	43	57	17,5	38,1	41	3/4-16 (08)	8,7	24,4	M8x30	5/16-18 UNC x 1-1/4	BFX-301-J08-W66	
			5075	5075	.39	.63	1.69	2.24	.69	1.50	1.61		.34	53.68				
13	1/2		350	350	12,3	16	43	57	17,5	38,1	41	7/8-14 (10)	8,7	24,2	M8x30	5/16-18 UNC x 1-1/4	BFX-301-J10-W66	
			5075	5075	.48	.63	1.69	2.24	.69	1.50	1.61		.34	53.24				
19	3/4		350	350	15,5	18	50	67	22,3	47,6	49	1-1/16-12 (12)	10,5	42,2	M10x35	3/8-16 UNC x 1-1/2	BFX-302-J12-W66	
			5075	5075	.61	.71	1.97	2.64	.88	1.87	1.93		.41	92.84				
25	1		250	315	21,5	18	54	72	26,2	52,4	52	1-5/16-12 (16)	10,5	48,8	M10x35	3/8-16 UNC x 1-1/2	BFX-303-J16-W66	
			3625	4568	.85	.71	2.13	2.83	1.03	2.06	2.05		.41	107.36				
32	1-1/4		200	200	21,5	21	68	82	30,2	58,7	56	1-5/16-12 (16)	11,5 (13,5)	73,3	M10x40 (M12x40)	7/16-14 UNC x 1-1/2	BFX-304-J16-W66	
			2900	2900	.85	.83	2.68	3.23	1.19	2.31	2.20		.45 (.53)	161.26				
32	1-1/4		200	200	27,5	21	68	82	30,2	58,7	58	1-5/8-12 (20)	11,5 (13,5)	77,4	M10x40 (M12x40)	7/16-14 UNC x 1-1/2	BFX-304-J20-W66	
			2900	2900	1.08	.83	2.68	3.23	1.19	2.31	2.28		.45 (.53)	170.28				
38	1-1/2		160	160	33	24	74	96	35,7	69,9	67	1-7/8-12 (24)	13,5 (14,5)	114,7	M12x45 (M14x45)	7/16-14 UNC x 1-3/4	BFX-305-J24-W66	
			2320	2320	1.30	.94	2.91	3.78	1.41	2.75	2.64		.53 (.57)	252.34				

6000 PSI High Pressure Series (based on ISO 6162-2:2002)

Nominal Size	DN	(in)	PN ¹		Dimensions								T (UN/UNF)	ØK ³	Weight	for Bolts		Ordering Codes
			(bar/PSI)	10.9 (MH)	ØA	D	F	G	H	I	L	(^{kg/lbs}) ca.				Metric	UNC	
13	1/2		350	400	9,9	16	43	57	18,2	40,5	42	3/4-16 (08)	8,7	24,0	M8x30	5/16-18 UNC x 1-1/4	BFX-601-J08-W66	
			5075	5800	.39	.63	1.69	2.24	.72	1.59	1.65		.34	52.80				
13	1/2		350	400	12,3	16	43	57	18,2	40,5	45	7/8-14 (10)	8,7	25,1	M8x30	5/16-18 UNC x 1-1/4	BFX-601-J10-W66	
			5075	5800	.48	.63	1.69	2.24	.72	1.59	1.77		.34	55.22				
19	3/4		350	400	15,5	18	54	72	23,8	50,8	51	1-1/16-12 (12)	10,5	49,2	M10x35	3/8-16 UNC x 1-1/2	BFX-602-J12-W66	
			5075	5800	.61	.71	2.13	2.83	.94	2.00	2.01		.41	108.24				
25	1		350	400	21,5	21	68	82	27,8	57,2	59	1-5/16-12 (16)	13	72,9	M12x40	7/16-14 UNC x 1-3/4	BFX-603-J16-W66 ²	
			5075	5800	.85	.83	2.68	3.23	1.09	2.25	2.32		.51	160.38				
32	1-1/4		350	400	21,5	24	75	95	31,6	66,6	64	1-5/16-12 (16)	13,5	107,0	M12x45	1/2-13 UNC x 1-3/4	BFX-604-J16-W66	
			5075	5800	.85	.94	2.95	3.74	1.24	2.62	2.52		.53	235.40				
32	1-1/4		350	400	21,5	24	75	95	31,6	66,6	64	1-5/16-12 (16)	15	106,9	M14x45		BFX-604-J16-M14-W66	
			5075	5800	.85	.94	2.95	3.74	1.24	2.62	2.52		.59	235.18				
32	1-1/4		350	400	27,5	24	75	95	31,6	66,6	66	1-5/8-12 (20)	13,5	106,9	M12x45	1/2-13 UNC x 1-3/4	BFX-604-J20-W66	
			5075	5800	1.08	.94	2.95	3.74	1.24	2.62	2.60		.53	235.18				
32	1-1/4		350	400	27,5	24	75	95	31,6	66,6	66	1-5/8-12 (20)	15	111,7	M14x45		BFX-604-J20-M14-W66	
			5075	5800	1.08	.94	2.95	3.74	1.24	2.62	2.60		.59	245.74				
38	1-1/2		350	400	33	27	84	108	36,5	79,3	73	1-7/8-12 (24)	17	160,6	M16x50	5/8-11 UNC x 2	BFX-605-J24-W66	
			5075	5800	1.30	1.06	3.31	4.25	1.44	3.12	2.87		.67	353.32				

Materials / Ordering Options / Examples

- * SAE Single-Part Flange (without O-ring) made of Steel S355J0 / C45 or equivalent, zinc-plated and thick-film-passivated **BFX-...-J*-W66**
- * SAE Single-Part Flange (without O-ring) made of Stainless Steel V4A – 1.4404 (on request) **BFX-...-J*-W5**
- * Kit including Metric bolts 8.8, spring rings, O-ring made of NBR (Buna-N®) **BFX-...-J*-W66-K**
- * Kit including Metric bolts 8.8, spring rings, O-ring made of FKM/FPM (Viton®) **BFX-...-J*-V-W66-K**
- * Kit including Metric bolts 10.9, spring rings, O-ring made of NBR (Buna-N®) **BFX-...-J*-MH-W129-K**
- * Kit including UNC bolts (Grade 8), spring rings, O-ring made of NBR (Buna-N®) **BFX-...-J**-U-W129-K**

Please always indicate Thread Size.

¹ The maximum working pressure PN (bar/PSI) applies only to the flange itself and depends on the bolts used (Grade 8.8 / 10.9). The actual maximum working pressure depends on the thickness and the quality of the tube used.

² For UNC threaded bolts, use hexagon head bolts only. Please note that these do not belong to our product range.

³ Alternative options shown in brackets are available on request.

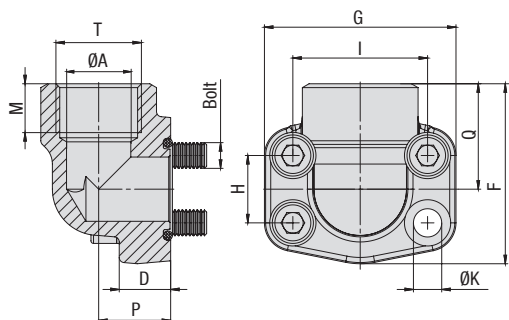

SAE 90° Single-Part Flange with Female BSPP Thread
 Type BFX90-G • 3000 / 6000 PSI Series

3000 PSI Standard Pressure Series (based on ISO 6162-1:2002)

Nominal Size		PN ¹ (bar/PSI)		Dimensions (mm/in)										Weight (kg/lbs) ca. per 100		for Bolts		Ordering Codes
DN	(in)	8.8	10.9 (MH)	ØA	D	F	G	H	I	M	P	Q	T (BSPP)	ØK ³	Metric ³	UNC		
13	1/2	350	350	13	16	60	54	17,5	38,1	19	20	37	1/2	8,7	31,3	M8x30	5/16-18 UNC x 1-1/4	BFX90-301-G-W1
		5075	5075	.51	.63	2.36	2.13	.69	1.50	.75	.79	1.46		.34	68.86			
13	1/2	350	350	13	16	60	54	17,5	38,1	19	20	37	3/8 (06)	8,7	30,5	M8x30	5/16-18 UNC x 1-1/4	BFX90-301-G06-W1
		5075	5075	.51	.63	2.36	2.13	.69	1.50	.75	.79	1.46		.34	67.10			
19	3/4	350	350	19	18	63	65	22,3	47,6	19	24	38	3/4	10,5	44,4	M10x35	3/8-16 UNC x 1-1/2	BFX90-302-G-W1
		5075	5075	.75	.71	2.48	2.56	.88	1.87	.75	.94	1.50		.41	97.68			
25	1	250	315	25	19	70	70	26,2	52,4	20	28	43	1	10,5	60,0	M10x35	3/8-16 UNC x 1-1/2	BFX90-303-G-W1
		3625	4568	.98	.75	2.76	2.76	1.03	2.06	.79	1.10	1.69		.41	132.00			
32	1-1/4	200	250	32	21	85	79	30,2	58,7	22	34	51	1-1/4	11,5 (13,5)	85,8	M10x40 (M12x40)	7/16-14 UNC x 1-1/2	BFX90-304-G-W1
		2900	3625	1.26	.83	3.35	3.11	1.19	2.31	.87	1.34	2.01		.45 (.53)	188.76			
38	1-1/2	200	200	38	25	95	93	35,7	69,9	25	38	56	1-1/2	13,5 (14,5)	123,0	M12x45 (M14x45)	1/2-13 UNC x 1-3/4	BFX90-305-G-W1
		2900	2900	1.50	.98	3.74	3.66	1.41	2.75	.98	1.50	2.20		.53 (.57)	270.60			
51	2	160	200	51	25	110	110	42,9	77,8	28	42	65	2	13,5 (14,5)	188,7	M12x45 (M14x45)	1/2-13 UNC x 1-3/4	BFX90-306-G-W1
		2320	2900	2.01	.98	4.33	4.33	1.69	3.06	1.10	1.65	2.56		.53 (.57)	415.14			

6000 PSI High Pressure Series (based on ISO 6162-2:2002)

Nominal Size		PN ¹ (bar/PSI)		Dimensions (mm/in)										Weight (kg/lbs) ca. per 100		for Bolts		Ordering Codes
DN	(in)	8.8	10.9 (MH)	ØA	D	F	G	H	I	M	P	Q	T (BSPP)	ØK	Metric	UNC		
13	1/2	350	420	13	16	60	56	18,2	40,5	19	20	37	1/2	8,7	29,6	M8x30	5/16-18 UNC x 1-1/4	BFX90-601-G-W1
		5075	6090	.51	.63	2.36	2.20	.72	1.59	.75	.79	1.46		.34	65.12			
13	1/2	350	420	13	16	60	56	18,2	40,5	19	20	37	3/8 (06)	8,7	30,2	M8x30	5/16-18 UNC x 1-1/4	BFX90-601-G06-W1
		5075	6090	.51	.63	2.36	2.20	.72	1.59	.75	.79	1.46		.34	66.44			
19	3/4	350	420	19	19	70	72	23,8	50,8	20	28	43	3/4	10,5	70,8	M10x35	3/8-16 UNC x 1-1/2	BFX90-602-G-W1
		5075	6090	.75	.75	2.76	2.83	.94	2.00	.79	1.10	1.69		.41	155.76			
25	1	350	420	25	21	85	79	27,8	57,2	22	34	51	1	13	109,3	M12x45	7/16-14 UNC x 1-3/4	BFX90-603-G-W1 ²
		5075	6090	.98	.83	3.35	3.11	1.09	2.25	.87	1.34	2.01		.51	240.46			
32	1-1/4	350	420	32	25	95	93	31,6	66,6	25	38	56	1-1/4	13,5	152,4	M12x45	1/2-13 UNC x 1-3/4	BFX90-604-G-W1
		5075	6090	1.26	.98	3.74	3.66	1.24	2.62	.98	1.50	2.20		.53	335.28			
32	1-1/4	350	420	32	25	95	93	31,6	66,6	25	38	56	1-1/4	15	144,7	M14x45	/	BFX90-604-G-M14-W1
		5075	6090	1.26	.98	3.74	3.66	1.24	2.62	.98	1.50	2.20		.59	318.34			
38	1-1/2	350	420	38	25	110	110	36,5	79,3	28	42	65	1-1/2	17	245,9	M16x50	5/8-11 UNC x 2	BFX90-605-G-W1
		5075	6090	1.50	.98	4.33	4.33	1.44	3.12	1.10	1.65	2.56		.67	540.98			
51	2	350	420	51	35	132	134	44,5	96,8	33	45	75	2	21	364,3	M20x70	3/4-10 UNC x 2-3/4	BFX90-606-G-W1
		5075	6090	2.01	1.38	5.20	5.28	1.75	3.81	1.30	1.77	2.95		.83	801.46			

¹ The maximum working pressure PN (bar/PSI) applies only to the flange itself and depends on the bolts used (Grade 8.8 / 10.9). The actual maximum working pressure depends on the thickness and the quality of the tube used.

² For UNC threaded bolts, use hexagon head bolts only. Please note that these do not belong to our product range.

³ Alternative options shown in brackets are available on request.

Materials / Ordering Options / Examples

- * SAE Single-Part Flange (without O-ring) made of Steel S355J0 or equivalent, blank (oiled) BFX90-...-G-W1
- * SAE Single-Part Flange (without O-ring) made of Stainless Steel V4A - 1.4404 (on request) BFX90-...-G-W5
- * Size of connection thread deviating from the standard (e.g. 1-1/4 BSPP) BFX90-...-G20-W1
- * Kit including Metric bolts 8.8, spring rings, O-ring made of NBR (Buna-N®) BFX90-...-G-W46-K
- * Kit including Metric bolts 8.8, spring rings, O-ring made of FKM/FPM (Viton®) BFX90-...-G-V-W46-K
- * Kit including Metric bolts 10.9, spring rings, O-ring made of NBR (Buna-N®) BFX90-...-G-MH-W1-K
- * Kit including UNC bolts (Grade 8), spring rings, O-ring made of NBR (Buna-N®) BFX90-...-G-U-W1-K



**SAE 90° Single-Part Flange with Female NPT Thread
Type BFX90-N • 3000 / 6000 PSI Series**

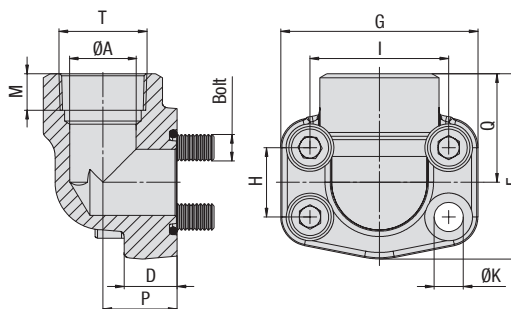

3000 PSI Standard Pressure Series (based on ISO 6162-1:2002)

Nominal Size	DN	(in)	PN ¹ (bar/PSI)		Dimensions (mm/in)										T (NPT)	ØK ³	Weight for Bolts (kg/lbs) ca.			Ordering Codes
			8.8	10.9 (MH)	ØA	D	F	G	H	I	M	P	Q	per 100			Metric ³	UNC		
13	1/2		350	350	13	16	60	54	17,5	38,1	19	20	37	1/2	8,7	31,3	M8x30	5/16-18 UNC x 1-1/4	BFX90-301-N-W1	
			5075	5075	.51	.63	2.36	2.13	.69	1.50	.75	.79	1.46							.34
13	1/2		350	350	13	16	60	54	17,5	38,1	19	20	37	3/8 (06)	8,7	31,3	M8x30	5/16-18 UNC x 1-1/4	BFX90-301-N06-W1	
			5075	5075	.51	.63	2.36	2.13	.69	1.50	.75	.79	1.46							.34
19	3/4		350	350	19	18	63	65	22,3	47,6	19	24	38	3/4	10,5	47,1	M10x35	3/8-16 UNC x 1-1/2	BFX90-302-N-W1	
			5075	5075	.75	.71	2.48	2.56	.88	1.87	.75	.94	1.50							.41
25	1		250	315	25	19	70	70	26,2	52,4	20	28	43	1	10,5	58,2	M10x35	3/8-16 UNC x 1-1/2	BFX90-303-N-W1	
			3625	4568	.98	.75	2.76	2.76	1.03	2.06	.79	1.10	1.69							.41
32	1-1/4		200	250	32	21	85	79	30,2	58,7	22	34	51	1-1/4	11,5 (13,5)	87,9	M10x40 (M12x40)	7/16-14 UNC x 1-1/2	BFX90-304-N-W1	
			2900	3625	1.26	.83	3.35	3.11	1.19	2.31	.87	1.34	2.01							.45 (.53)
38	1-1/2		200	200	38	25	95	93	35,7	69,9	25	38	56	1-1/2	13,5 (14,5)	126,2	M12x45 (M14x45)	1/2-13 UNC x 1-3/4	BFX90-305-N-W1	
			2900	2900	1.50	.98	3.74	3.66	1.41	2.75	.98	1.50	2.20							.53 (.57)
51	2		160	200	51	25	110	110	42,9	77,8	28	42	65	2	13,5 (14,5)	189,0	M12x45 (M14x45)	1/2-13 UNC x 1-3/4	BFX90-306-N-W1	
			2320	2900	2.01	.98	4.33	4.33	1.69	3.06	1.10	1.65	2.56							.53 (.57)

6000 PSI High Pressure Series (based on ISO 6162-2:2002)

Nominal Size	DN	(in)	PN ¹ (bar/PSI)		Dimensions (mm/in)										T (NPT)	ØK ³	Weight for Bolts (kg/lbs) ca.			Ordering Codes
			8.8	10.9 (MH)	ØA	D	F	G	H	I	M	P	Q	per 100			Metric	UNC		
13	1/2		350	420	13	16	60	56	18,2	40,5	19	20	37	1/2	8,7	30,0	M8x30	5/16-18 UNC x 1-1/4	BFX90-601-N-W1	
			5075	6090	.51	.63	2.36	2.20	.72	1.59	.75	.79	1.46							.34
13	1/2		350	420	13	16	60	56	18,2	40,5	19	20	37	3/8 (06)	8,7	30,0	M8x30	5/16-18 UNC x 1-1/4	BFX90-601-N06-W1	
			5075	6090	.51	.63	2.36	2.20	.72	1.59	.75	.79	1.46							.34
19	3/4		350	420	19	19	70	72	23,8	50,8	20	28	43	3/4	10,5	66,6	M10x35	3/8-16 UNC x 1-1/2	BFX90-602-N-W1	
			5075	6090	.75	.75	2.76	2.83	.94	2.00	.79	1.10	1.69							.41
25	1		350	420	25	21	85	79	27,8	57,2	22	34	51	1	13	109,0	M12x45	7/16-14 UNC x 1-3/4	BFX90-603-N-W1 ²	
			5075	6090	.98	.83	3.35	3.11	1.09	2.25	.87	1.34	2.01							.51
32	1-1/4		350	420	32	25	95	93	31,6	66,6	25	38	56	1-1/4	13,5	145,0	M12x45	1/2-13 UNC x 1-3/4	BFX90-604-N-W1	
			5075	6090	1.26	.98	3.74	3.66	1.24	2.62	.98	1.50	2.20							.53
32	1-1/4		350	420	32	25	95	93	31,6	66,6	25	38	56	1-1/4	15	150,4	M14x45		BFX90-604-N-M14-W1	
			5075	6090	1.26	.98	3.74	3.66	1.24	2.62	.98	1.50	2.20							.59
38	1-1/2		350	420	38	25	110	110	36,5	79,3	28	42	65	1-1/2	17	246,0	M16x50	5/8-11 UNC x 2	BFX90-605-N-W1	
			5075	6090	1.50	.98	4.33	4.33	1.44	3.12	1.10	1.65	2.56							.67
51	2		350	420	51	35	132	134	44,5	96,8	33	45	75	2	21	364,0	M20x70	3/4-10 UNC x 2-3/4	BFX90-606-N-W1	
			5075	6090	2.01	1.38	5.20	5.28	1.75	3.81	1.30	1.77	2.95							.83

Materials / Ordering Options / Examples

- * SAE Single-Part Flange (without O-ring) made of Steel S355J0 or equivalent, blank (oiled)
- * SAE Single-Part Flange (without O-ring) made of Stainless Steel V4A – 1.4404 (on request)

BFX90-...-N-W1
BFX90-...-N-W5

- * Size of connection thread deviating from the standard (e.g. 3/8 NPT)

BFX90-...-N06-W1

- * Kit including Metric bolts 8.8, spring rings, O-ring made of NBR (Buna-N®)
- * Kit including Metric bolts 8.8, spring rings, O-ring made of FKM/FPM (Viton®)
- * Kit including Metric bolts 10.9, spring rings, O-ring made of NBR (Buna-N®)
- * Kit including UNC bolts (Grade 8), spring rings, O-ring made of NBR (Buna-N®)

BFX90-...-N-W46-K
BFX90-...-N-V-W46-K
BFX90-...-N-MH-W1-K
BFX90-...-N-U-W1-K

¹ The maximum working pressure PN (bar/PSI) applies only to the flange itself and depends on the bolts used (Grade 8.8 / 10.9). The actual maximum working pressure depends on the thickness and the quality of the tube used.

² For UNC threaded bolts, use hexagon head bolts only. Please note that these do not belong to our product range.

³ Alternative options shown in brackets are available on request.



SAE 90° Single-Part Butt-Weld Flange for High Pressure Tubes
Type BFX90-STC - 3000 / 6000 PSI Series

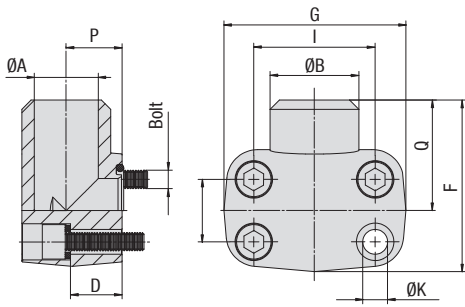

Version A



3000 PSI Standard Pressure Series (based on ISO 6162-1:2002)

Nominal Size		PN ¹ (bar/PSI)		Dimensions (mm/in)											Weight (kg/lbs) ca. per 100		for Bolts		Version	Ordering Codes
DN	(in)	8.8	10.9 (MH)	ØA	ØB	D	F	G	H	I	P	Q	ØK	Metric						
19	3/4	350	350	19	27	21	63	70	22,3	47,6	23	41	11	73,5	M10x40	A	BFX90-302-STC-27/19-W1 ²			
		5075	5075	.75	1.06	.83	2.48	2.76	.88	1.87	.91	1.61	.43	161.70						
25	1	350	350	23	34,5	24	72	75	26,2	52,4	25	48	11	85,0	M10x45	A	BFX90-303-STC-34.5/23-W1 ³			
		5075	5075	.91	1.36	.94	2.83	2.95	1.03	2.06	.98	1.89	.43	187.00						
32	1-1/4	250	315	31	43	25	82	86	30,2	58,7	27	54	11,5	80,0	M10x45	A	BFX90-304-STC-43/31-W1			
		3625	4568	1.22	1.69	.98	3.23	3.39	1.19	2.31	1.06	2.13	.45	176.00						
38	1-1/2	200	250	35	50	29	92	97	35,7	69,9	31,5	57	14	189,4	M12x50	A	BFX90-305-STC-50/35-W1			
		2900	3625	1.38	1.97	1.14	3.62	3.82	1.41	2.75	1.24	2.24	.55	416.68						
51	2	200	200	48	65	50	99	100	42,9	77,8	37,5	63	14	214,8	M12x70	A	BFX90-306-STC-65/48-W1			
		2900	2900	1.89	2.56	1.97	3.90	3.94	1.69	3.06	1.48	2.48	.55	472.56						

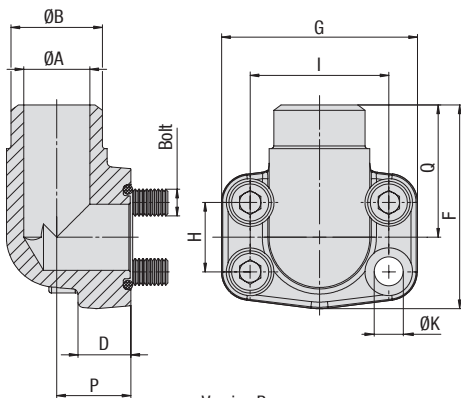

Version B



6000 PSI High Pressure Series (based on ISO 6162-2:2002)

Nominal Size		PN ¹ (bar/PSI)		Dimensions (mm/in)											Weight (kg/lbs) ca. per 100		for Bolts		Version	Ordering Codes
DN	(in)	8.8	10.9 (MH)	ØA	ØB	D	F	G	H	I	P	Q	ØK	Metric						
19	3/4	350	420	19	28	19	70	71	23,8	50,8	22	40	11	50,1	M10x35	B	BFX90-602-STC-28/19-W1			
		5075	6090	.75	1.10	.75	2.76	2.80	.94	2.00	.87	1.57	.43	110.22						
25	1	350	420	25	34	24	82	81	27,8	57,2	27	47	13	77,2	M12x45	B	BFX90-603-STC-34/25-W1			
		5075	6090	.98	1.34	.94	3.23	3.19	1.09	2.25	1.06	1.85	.51	169.84						
32	1-1/4	350	420	32	42	27	95	95	31,8	66,6	32	56	15	119,6	M14x50	B	BFX90-604-STC-42/32-M14-W1			
		5075	6090	1.26	1.65	1.06	3.74	3.74	1.25	2.62	1.26	2.20	.59	263.12						
38	1-1/2	350	420	38	48	30	115	113	36,5	79,3	40	68	17	193,7	M16x50	B	BFX90-605-STC-48/38-W1			
		5075	6090	1.50	1.89	1.18	4.53	4.45	1.44	3.12	1.57	2.68	.67	426.14						

¹ The maximum working pressure PN (bar/PSI) applies only to the flange itself and depends on the bolts used (Grade 8.8 / 10.9). The actual maximum working pressure depends on the thickness and the quality of the tube used.

² Deviant O-ring size: 25,07 x 2,62 mm / .99 x .10 in

³ Deviant O-ring size: 28,17 x 3,53 mm / 1.11 x .14 in

Materials / Ordering Options / Examples

- * SAE Single-Part Flange (without O-ring) made of Steel S355J0 or equivalent, blank (oiled) **BFX90-...-STC-**/**-W1**
- * SAE Single-Part Flange (without O-ring) made of Stainless Steel V4A – 1.4404 (on request) **BFX90-...-STC-**/**-W5**
- * Kit including Metric bolts 8.8, spring rings, O-ring made of NBR (Buna-N®) **BFX90-...-STC-**/**-W46-K**
- * Kit including Metric bolts 8.8, spring rings, O-ring made of FKM/FPM (Viton®) **BFX90-...-STC-V-**/**-W46-K**
- * Kit including Metric bolts 10.9, spring rings, O-ring made of NBR (Buna-N®) **BFX90-...-STC-**/**-MH-W1-K**

Please always indicate ØB / ØA.



**SAE 90° Single-Part Butt-Weld Flange for Metric Tubes
Type BFX90-SRE • 3000 PSI Series**

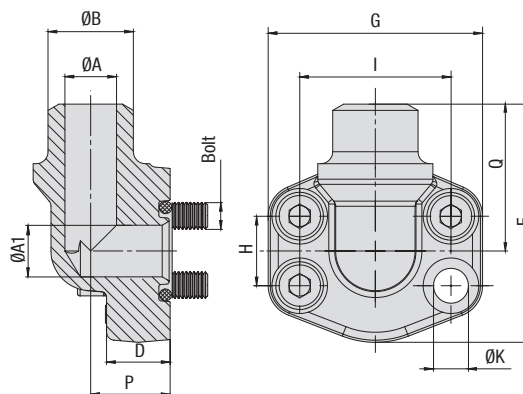

3000 PSI Standard Pressure Series (based on ISO 6162-1:2002)

Nominal Size	DN	(in)	PN ¹ (bar/PSI)		Dimensions (mm/in)													Weight (kg/lbs) ca.		for Bolts		Ordering Codes
			8.8	10.9 (MH)	ØA	ØA1	ØB	D	F	G	H	I	P	Q	ØK ³	per 100	Metric ³	UNC				
13	1/2		350	350	14	13	20	16	60	54	17,5	38,1	20	37	8,7	26,9	M8x30	5/16-18 UNC x 1-1/4	BFX90-301-SRE-20/14-W1			
			5075	5075	.55	.51	.79	.63	2.36	2.13	.69	1.50	.79	1.46	.34	59.18						
13	1/2		350	350	18	13	22	16	60	54	17,5	38,1	20	37	8,7	27,5	M8x30	5/16-18 UNC x 1-1/4	BFX90-301-SRE-22/18-W1			
			5075	5075	.71	.51	.87	.63	2.36	2.13	.69	1.50	.79	1.46	.34	60.50						
13	1/2		350	350	19	13	25	16	60	54	17,5	38,1	20	37	8,7	28,0	M8x30	5/16-18 UNC x 1-1/4	BFX90-301-SRE-25/19-W1			
			5075	5075	.75	.51	.98	.63	2.36	2.13	.69	1.50	.79	1.46	.34	61.60						
19	3/4		350	350	19	19	25	18	63	65	22,3	47,6	24	38	10,5	40,6	M10x35	3/8-16 UNC x 1-1/2	BFX90-302-SRE-25/19-W1			
			5075	5075	.75	.75	.98	.71	2.48	2.56	.88	1.87	.94	1.50	.41	89.32						
19	3/4		350	350	22	19	28	18	63	65	22,3	47,6	24	38	10,5	39,0	M10x35	3/8-16 UNC x 1-1/2	BFX90-302-SRE-28/22-W1			
			5075	5075	.87	.75	1.10	.71	2.48	2.56	.88	1.87	.94	1.50	.41	85.80						
19	3/4		350	350	22	19	30	18	63	65	22,3	47,6	24	38	10,5	40,0	M10x35	3/8-16 UNC x 1-1/2	BFX90-302-SRE-30/22-W1			
			5075	5075	.87	.75	1.18	.71	2.48	2.56	.88	1.87	.94	1.50	.41	88.00						
19	3/4		350	350	27	19	35	18	63	65	22,3	47,6	24	38	10,5	42,0	M10x35	3/8-16 UNC x 1-1/2	BFX90-302-SRE-35/27-W1			
			5075	5075	1.06	.75	1.38	.71	2.48	2.56	.88	1.87	.94	1.50	.41	92.40						
25	1		250	315	22	25	30	19	70	70	26,2	52,4	28	43	10,5	56,5	M10x35	3/8-16 UNC x 1-1/2	BFX90-303-SRE-30/22-W1			
			3625	4568	.87	.98	1.18	.75	2.76	2.76	1.03	2.06	1.10	1.69	.41	124.30						
25	1		250	315	27	25	35	19	70	70	26,2	52,4	28	43	10,5	53,3	M10x35	3/8-16 UNC x 1-1/2	BFX90-303-SRE-35/27-W1			
			3625	4568	1.06	.98	1.38	.75	2.76	2.76	1.03	2.06	1.10	1.69	.41	117.26						
25	1		250	315	30	25	38	19	70	70	26,2	52,4	28	43	10,5	55,9	M10x35	3/8-16 UNC x 1-1/2	BFX90-303-SRE-38/30-W1			
			3625	4568	1.18	.98	1.50	.75	2.76	2.76	1.03	2.06	1.10	1.69	.41	122.98						
25	1		250	315	36	25	42	19	70	70	26,2	52,4	28	43	10,5	51,8	M10x35	3/8-16 UNC x 1-1/2	BFX90-303-SRE-42/36-W1			
			3625	4568	1.42	.98	1.65	.75	2.76	2.76	1.03	2.06	1.10	1.69	.41	113.96						
32	1-1/4		200	250	30	32	38	21	85	79	30,2	58,7	34	51	11,5 (13,5)	79,2	M10x40 (M12x40)	7/16-14 UNC x 1-1/2	BFX90-304-SRE-38/30-W1			
			2900	3625	1.18	1.26	1.50	.83	3.35	3.11	1.19	2.31	1.34	2.01	.45 (.53)	174.24						
32	1-1/4		200	250	36	32	42	21	85	79	30,2	58,7	34	51	11,5 (13,5)	78,3	M10x40 (M12x40)	7/16-14 UNC x 1-1/2	BFX90-304-SRE-42/36-W1			
			2900	3625	1.42	1.26	1.65	.83	3.35	3.11	1.19	2.31	1.34	2.01	.45 (.53)	172.26						
32	1-1/4		200	250	39	32	49	21	85	79	30,2	58,7	34	51	11,5 (13,5)	82,5	M10x40 (M12x40)	7/16-14 UNC x 1-1/2	BFX90-304-SRE-49/39-W1			
			2900	3625	1.54	1.26	1.93	.83	3.35	3.11	1.19	2.31	1.34	2.01	.45 (.53)	181.50						
38	1-1/2		200	200	30	38	38	25	95	93	35,7	69,9	38	56	13,5 (14,5)	135,0	M12x45 (M14x45)	1/2-13 UNC x 1-3/4	BFX90-305-SRE-38/30-W1			
			2900	2900	1.18	1.50	1.50	.98	3.74	3.66	1.41	2.75	1.50	2.20	.53 (.57)	297.00						
38	1-1/2		200	200	36	38	42	25	95	93	35,7	69,9	38	56	13,5 (14,5)	124,1	M12x45 (M14x45)	1/2-13 UNC x 1-3/4	BFX90-305-SRE-42/36-W1			
			2900	2900	1.42	1.50	1.65	.98	3.74	3.66	1.41	2.75	1.50	2.20	.53 (.57)	273.02						
38	1-1/2		200	200	39	38	49	25	95	93	35,7	69,9	38	56	13,5 (14,5)	134,4	M12x45 (M14x45)	1/2-13 UNC x 1-3/4	BFX90-305-SRE-49/39-W1			
			2900	2900	1.54	1.50	1.93	.98	3.74	3.66	1.41	2.75	1.50	2.20	.53 (.57)	295.68						
51	2		160	200	49	51	61	25	110	110	42,9	77,8	42	65	13,5 (14,5)	199,7	M12x45 (M14x45)	1/2-13 UNC x 1-3/4	BFX90-306-SRE-61/49-W1			
			2320	2900	1.93	2.01	2.40	.98	4.33	4.33	1.69	3.06	1.65	2.56	.53 (.57)	439.34						

Materials / Ordering Options / Examples

- * SAE Single-Part Flange (without O-ring) made of Steel S355J0 or equivalent, blank (oiled)
- * SAE Single-Part Flange (without O-ring) made of Stainless Steel V4A – 1.4404 (on request)

- * Kit including Metric bolts 8.8, spring rings, O-ring made of NBR (Buna-N®)
- * Kit including Metric bolts 8.8, spring rings, O-ring made of FKM/FPM (Viton®)
- * Kit including Metric bolts 10.9, spring rings, O-ring made of NBR (Buna-N®)
- * Kit including UNC bolts (Grade 8), spring rings, O-ring made of NBR (Buna-N®)

BFX90-...-SRE-*-W1**
BFX90-...-SRE-*-W5**

BFX90-...-SRE-*-W46-K**
BFX90-...-SRE-*-V-W46-K**
BFX90-...-SRE-*-MH-W1-K**
BFX90-...-SRE-*-U-W1-K**

Please always indicate ØB / ØA.

¹ The maximum working pressure PN (bar/PSI) applies only to the flange itself and depends on the bolts used (Grade 8.8 / 10.9). The actual maximum working pressure depends on the thickness and the quality of the tube used.

³ Alternative options shown in brackets are available on request.



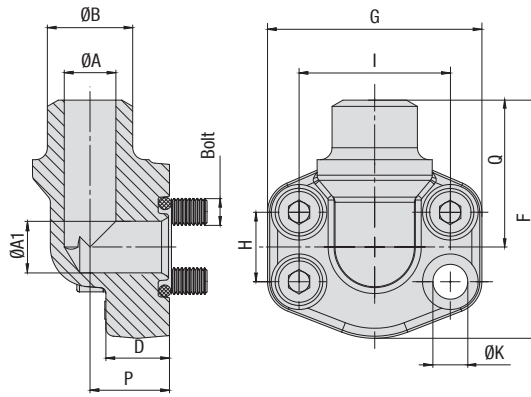

SAE 90° Single-Part Butt-Weld Flange for Metric Tubes
Type BFX90-SRE - 6000 PSI Series



6000 PSI High Pressure Series (based on ISO 6162-2:2002)

C

Nominal Size	DN	(in)	PN ¹ (bar/PSI)		Dimensions (mm/in)													Weight (¹⁰ /lbs) ca. per 100	for Bolts		Ordering Codes
			8.8	10.9 (MH)	ØA	ØA1	ØB	D	F	G	H	I	P	Q	ØK	Metric	UNC				
13	1/2	350	420	14	13	20	16	60	54	18,2	40,5	20	37	8,7	26,6	M8x30	5/16-18 UNC x 1-1/4	BFX90-601-SRE-20/14-W1			
		5075	6090	.55	.51	.79	.63	2.36	2.13	.72	1.59	.79	1.46	.34	58.52						
13	1/2	350	420	17	13	25	16	60	54	18,2	40,5	20	37	8,7	28,3	M8x30	5/16-18 UNC x 1-1/4	BFX90-601-SRE-25/17-W1			
		5075	6090	.67	.51	.98	.63	2.36	2.13	.72	1.59	.79	1.46	.34	62.26						
19	3/4	350	420	17	19	25	19	70	72	23,8	50,8	28	43	10,5	62,2	M10x35	3/8-16 UNC x 1-1/2	BFX90-602-SRE-25/17-W1			
		5075	6090	.67	.75	.98	.75	2.76	2.83	.94	2.00	1.10	1.69	.41	136.84						
19	3/4	350	420	22	19	30	19	70	72	23,8	50,8	28	43	10,5	60,6	M10x35	3/8-16 UNC x 1-1/2	BFX90-602-SRE-30/22-W1			
		5075	6090	.87	.75	1.18	.75	2.76	2.83	.94	2.00	1.10	1.69	.41	133.32						
25	1	350	420	22	25	30	21	85	79	27,8	57,2	34	51	13,5	94,4	M12x45	7/16-14 UNC x 1-3/4	BFX90-603-SRE-30/22-W1 ²			
		5075	6090	.87	.98	1.18	.83	3.35	3.11	1.09	2.25	1.34	2.01	.53	207.68						
25	1	350	420	28	25	38	21	85	79	27,8	57,2	34	51	13,5	90,9	M12x45	7/16-14 UNC x 1-3/4	BFX90-603-SRE-38/28-W1 ²			
		5075	6090	1.10	.98	1.50	.83	3.35	3.11	1.09	2.25	1.34	2.01	.53	199.98						
32	1-1/4	350	420	28	32	38	25	95	93	31,8	66,6	38	56	13,5	139,0	M12x45	1/2-13 UNC x 1-3/4	BFX90-604-SRE-38/28-W1			
		5075	6090	1.10	1.26	1.50	.98	3.74	3.66	1.25	2.62	1.50	2.20	.53	305.80						
32	1-1/4	350	420	28	32	38	25	95	93	31,8	66,6	38	56	15	138,6	M14x45		BFX90-604-SRE-38/28-M14-W1			
		5075	6090	1.10	1.26	1.50	.98	3.74	3.66	1.25	2.62	1.50	2.20	.59	304.92						
32	1-1/4	350	420	32	32	49	25	95	93	31,8	66,6	38	56	13,5	145,0	M12x45	1/2-13 UNC x 1-3/4	BFX90-604-SRE-49/32 -W1			
		5075	6090	1.26	1.26	1.93	.98	3.74	3.66	1.25	2.62	1.50	2.20	.53	319.00						
32	1-1/4	350	420	32	32	49	25	95	93	31,8	66,6	38	56	15	146,0	M14x45		BFX90-604-SRE-49/32-M14-W1			
		5075	6090	1.26	1.26	1.93	.98	3.74	3.66	1.25	2.62	1.50	2.20	.59	321.20						
38	1-1/2	350	420	28	38	38	25	110	110	36,5	79,3	42	65	17	240,3	M16x50	5/8-11 UNC x 2	BFX90-605-SRE-38/28-W1			
		5075	6090	1.10	1.50	1.50	.98	4.33	4.33	1.44	3.12	1.65	2.56	.67	528.66						
38	1-1/2	350	420	32	38	49	25	110	110	36,5	79,3	42	65	17	241,1	M16x50	5/8-11 UNC x 2	BFX90-605-SRE-49/32-W1			
		5075	6090	1.26	1.50	1.93	.98	4.33	4.33	1.44	3.12	1.65	2.56	.67	530.42						
38	1-1/2	350	420	40	38	61	25	110	110	36,5	79,3	42	65	17	236,2	M16x50	5/8-11 UNC x 2	BFX90-605-SRE-61/40-W1			
		5075	6090	1.57	1.50	2.40	.98	4.33	4.33	1.44	3.12	1.65	2.56	.67	519.64						
51	2	350	420	40	51	61	35	132	134	44,5	96,8	45	75	21	374,6	M20x70	3/4-10 UNC x 2-3/4	BFX90-606-SRE-61/40-W1			
		5075	6090	1.57	2.01	2.40	1.38	5.20	5.28	1.75	3.81	1.77	2.95	.83	824.12						
51	2	350	420	50	51	76	35	132	134	44,5	96,8	45	75	21	387,4	M20x70	3/4-10 UNC x 2-3/4	BFX90-606-SRE-76/50-W1			
		5075	6090	1.97	2.01	2.99	1.38	5.20	5.28	1.75	3.81	1.77	2.95	.83	852.28						

¹ The maximum working pressure PN (bar/PSI) applies only to the flange itself and depends on the bolts used (Grade 8.8 / 10.9). The actual maximum working pressure depends on the thickness and the quality of the tube used.

² For UNC threaded bolts, use hexagon head bolts only. Please note that these do not belong to our product range.

Materials / Ordering Options / Examples

- * SAE Single-Part Flange (without O-ring) made of Steel S355J0 or equivalent, blank (oiled) **BFX90-...-SRE-...-W1**
- * SAE Single-Part Flange (without O-ring) made of Stainless Steel V4A - 1.4404 (on request) **BFX90-...-SRE-...-W5**
- * Kit including Metric bolts 8.8, spring rings, O-ring made of NBR (Buna-N®) **BFX90-...-SRE-...-W46-K**
- * Kit including Metric bolts 8.8, spring rings, O-ring made of FKM/FPM (Viton®) **BFX90-...-SRE-...-V-W46-K**
- * Kit including Metric bolts 10.9, spring rings, O-ring made of NBR (Buna-N®) **BFX90-...-SRE-...-MH-W1-K**
- * Kit including UNC bolts (Grade 8), spring rings, O-ring made of NBR (Buna-N®) **BFX90-...-SRE-...-U-W1-K**

Please always indicate ØB / ØA.



**SAE 90° Single-Part Socket-Weld Flange
Type BFX90-ES ▪ 3000 PSI Series**

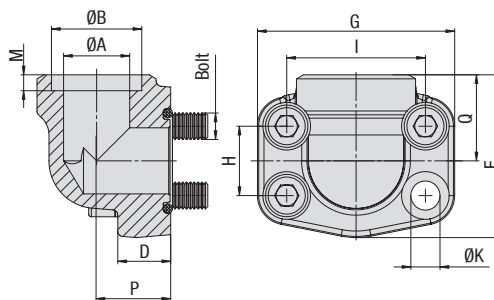

3000 PSI Standard Pressure Series (based on ISO 6162-1:2002)

Nominal Size		PN ¹ (bar/PSI)		Dimensions (mm/in)												Weight (kg/lbs) ca.		for Bolts		Ordering Codes
DN	(in)	8.8	10.9 (MH)	ØA	ØB	D	F	G	H	I	M	P	Q	ØK ³	per 100	Metric ³	UNC			
13	1/2	350	350	13	21,6	16	60	54	17,5	38,1	10	20	37	8,7	30,5	M8x30	5/16-18 UNC x 1-1/4	BFX90-301-ES-21.6/13-W1		
		5075	5075	.51	.85	.63	2.36	2.13	.69	1.50	.39	.79	1.46	.34	67.10					
13	1/2	350	350	13	17,5	16	60	54	17,5	38,1	10	20	37	8,7	31,1	M8x30	5/16-18 UNC x 1-1/4	BFX90-301-ES-17.5/13-W1		
		5075	5075	.51	.69	.63	2.36	2.13	.69	1.50	.39	.79	1.46	.34	68.42					
19	3/4	350	350	19	27,2	18	63	65	22,3	47,6	10	24	38	10,5	45,3	M10x35	3/8-16 UNC x 1-1/2	BFX90-302-ES-27.2/19-W1		
		5075	5075	.75	1.07	.71	2.48	2.56	.88	1.87	.39	.94	1.50	.41	99.66					
25	1	250	315	25	34	19	70	70	26,2	52,4	12	28	43	10,5	57,9	M10x35	3/8-16 UNC x 1-1/2	BFX90-303-ES-34/25-W1		
		3625	4568	.98	1.34	.75	2.76	2.76	1.03	2.06	.47	1.10	1.69	.41	127.38					
32	1-1/4	200	250	32	42,8	21	85	79	30,2	58,7	14	34	51	11,5 (13,5)	91,2	M10x40 (M12x40)	7/16-14 UNC x 1-1/2	BFX90-304-ES-42.8/32-W1		
		2900	3625	1.26	1.69	.83	3.35	3.11	1.19	2.31	.55	1.34	2.01	.45 (.53)	200.64					
38	1-1/2	200	200	38	48,6	25	95	93	35,7	69,9	16	38	56	13,5 (14,5)	129,2	M12x45 (M14x45)	1/2-13 UNC x 1-3/4	BFX90-305-ES-48.6/38-W1		
		2900	2900	1.50	1.91	.98	3.74	3.66	1.41	2.75	.63	1.50	2.20	.53 (.57)	284.24					
51	2	160	200	51	61	25	110	110	42,9	77,8	18	42	65	13,5 (14,5)	193,9	M12x45 (M14x45)	1/2-13 UNC x 1-3/4	BFX90-306-ES-61/51-W1		
		2320	2900	2.01	2.40	.98	4.33	4.33	1.69	3.06	.71	1.65	2.56	.53 (.57)	426.58					

Materials / Ordering Options / Examples

- * SAE Single-Part Flange (without O-ring) made of Steel S355J0 or equivalent, blank (oiled)
- * SAE Single-Part Flange (without O-ring) made of Stainless Steel V4A – 1.4404 (on request)

BFX90-...-ES--W1**
BFX90-...-ES--W5**

- * Kit including Metric bolts 8.8, spring rings, O-ring made of NBR (Buna-N®)
- * Kit including Metric bolts 8.8, spring rings, O-ring made of FKM/FPM (Viton®)
- * Kit including Metric bolts 10.9, spring rings, O-ring made of NBR (Buna-N®)
- * Kit including UNC bolts (Grade 8), spring rings, O-ring made of NBR (Buna-N®)

BFX90-...-ES--W46-K**
BFX90-...-ES--V-W46-K**
BFX90-...-ES--MH-W1-K**
BFX90-...-ES--U-W1-K**

Please always indicate ØB / ØA.

¹ The maximum working pressure PN (bar/PSI) applies only to the flange itself and depends on the bolts used (Grade 8.8 / 10.9). The actual maximum working pressure depends on the thickness and the quality of the tube used.

³ Alternative options shown in brackets are available on request.

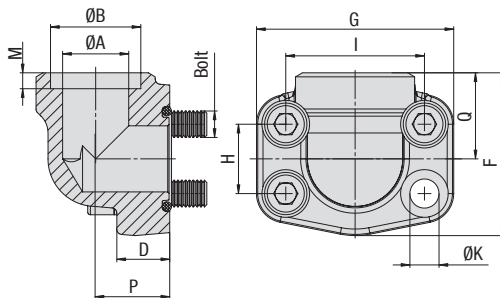

SAE 90° Single-Part Socket-Weld Flange
 Type BFX90-ES • 6000 PSI Series

6000 PSI High Pressure Series (based on ISO 6162-2:2002)

Nominal Size	PN ¹ (bar/PSI)	Dimensions (mm/in)													Weight (kg/lbs) ca. per 100	for Bolts		Ordering Codes
		8.8	10.9 (MH)	ØA	ØB	D	F	G	H	I	M	P	Q	ØK		Metric	UNC	
13	1/2	350	420	13	21,6	16	60	54	18,2	40,5	10	20	37	8,7	30,1	M8x30	5/16-18 UNC x 1-1/4	BFX90-601-ES-21.6/13-W1
		5075	6090	.51	.85	.63	2.36	2.13	.72	1.59	.39	.79	1.46	.34	66.22			
13	1/2	350	420	13	17,5	16	60	54	18,2	40,5	10	20	37	8,7	31,3	M8x30	5/16-18 UNC x 1-1/4	BFX90-601-ES-17.5/13-W1
		5075	6090	.51	.69	.63	2.36	2.13	.72	1.59	.39	.79	1.46	.34	68.86			
19	3/4	350	420	19	27,2	19	70	72	23,8	50,8	12	28	43	10,5	70,5	M10x35	3/8-16 UNC x 1-1/2	BFX90-602-ES-27.2/19-W1
		5075	6090	.75	1.07	.75	2.76	2.83	.94	2.00	.47	1.10	1.69	.41	155.10			
19	3/4	350	420	16/19	20,3	19	70	72	23,8	50,8	12	28	43	10,5	54,0	M10x35	3/8-16 UNC x 1-1/2	BFX90-602-ES-20.3/16-W1
		5075	6090	.63/.74	.80	.75	2.76	2.83	.94	2.00	.47	1.10	1.69	.41	118.80			
19	3/4	350	420	19	25,3	19	70	72	23,8	50,8	12	28	43	10,5	72,9	M10x35	3/8-16 UNC x 1-1/2	BFX90-602-ES-25.3/19-W1
		5075	6090	.75	1.00	.75	2.76	2.83	.94	2.00	.47	1.10	1.69	.41	160.38			
19	3/4	350	420	25/19	30,3	19	70	72	23,8	50,8	12	28	43	10,5	65,3	M10x35	3/8-16 UNC x 1-1/2	BFX90-602-ES-30.3/25-W1
		5075	6090	.98/.74	1.19	.75	2.76	2.83	.94	2.00	.47	1.10	1.69	.41	143.66			
25	1	350	420	25	34	21	85	79	27,8	57,2	14	34	51	13	108,2	M12x45	7/16-14 UNC x 1-3/4	BFX90-603-ES-34/25-W1 ²
		5075	6090	.98	1.34	.83	3.35	3.11	1.09	2.25	.55	1.34	2.01	.51	238.04			
25	1	350	420	25	30,3	21	85	79	27,8	57,2	14	34	51	13	113,9	M12x45	7/16-14 UNC x 1-3/4	BFX90-603-ES-30.3/25-W1 ²
		5075	6090	.98	1.19	.83	3.35	3.11	1.09	2.25	.55	1.34	2.01	.51	250.58			
32	1-1/4	350	420	32	42,8	25	95	93	31,8	66,6	16	38	56	13,5	161,7	M12x45	1/2-13 UNC x 1-3/4	BFX90-604-ES-42.8/32-W1
		5075	6090	1.26	1.69	.98	3.74	3.66	1.25	2.62	.63	1.50	2.20	.53	355.74			
32	1-1/4	350	420	32	42,8	25	95	93	31,8	66,6	16	38	56	15	145,5	M14x45		BFX90-604-ES-42.8/32-M14-W1
		5075	6090	1.26	1.69	.98	3.74	3.66	1.25	2.62	.63	1.50	2.20	.59	320.10			
32	1-1/4	350	420	22/32	30,3	25	95	93	31,8	66,6	16	38	56	13,5	177,0	M12x45	1/2-13 UNC x 1-3/4	BFX90-603-ES-30.3/22-W1
		5075	6090	.87/1.25	1.19	.98	3.74	3.66	1.25	2.62	.63	1.50	2.20	.53	389.40			
32	1-1/4	350	420	22/32	30,3	25	95	93	31,8	66,6	16	38	56	15	176,6	M14x45		BFX90-604-ES-30.3/22-M14-W1
		5075	6090	.87/1.25	1.19	.98	3.74	3.66	1.25	2.62	.63	1.50	2.20	.59	388.52			
32	1-1/4	350	420	27/32	38,3	25	95	93	31,8	66,6	16	38	56	13,5	176,6	M12x45	1/2-13 UNC x 1-3/4	BFX90-604-ES-38.3/27-W1
		5075	6090	1.06/1.25	1.51	.98	3.74	3.66	1.25	2.62	.63	1.50	2.20	.53	388.52			
32	1-1/4	350	420	27/32	38,3	25	95	93	31,8	66,6	16	38	56	15	161,7	M14x45		BFX90-604-ES-38.3/27-M14-W1
		5075	6090	1.06/1.25	1.51	.98	3.74	3.66	1.25	2.62	.63	1.50	2.20	.59	355.74			
38	1-1/2	350	420	38	48,6	25	110	110	36,5	79,3	18	42	65	17	254,2	M16x50	5/8-11 UNC x 2	BFX90-605-ES-48.6/38-W1
		5075	6090	1.50	1.91	.98	4.33	4.33	1.44	3.12	.71	1.65	2.56	.67	559.24			
51	2	350	420	51	61	35	132	134	36,5	79,3	28	45	75	21	333,6	M20x70	3/4-10 UNC x 2-3/4	BFX90-606-ES-61/51-W1
		5075	6090	2.01	2.40	1.38	5.20	5.28	1.44	3.12	1.10	1.77	2.95	.83	733.92			

¹ The maximum working pressure PN (bar/PSI) applies only to the flange itself and depends on the bolts used (Grade 8.8 / 10.9). The actual maximum working pressure depends on the thickness and the quality of the tube used.

² For UNC threaded bolts, use hexagon head bolts only. Please note that these do not belong to our product range.

Materials / Ordering Options / Examples

- * SAE Single-Part Flange (without O-ring) made of Steel S355J0 or equivalent, blank (oiled)
- * SAE Single-Part Flange (without O-ring) made of Stainless Steel V4A – 1.4404 (on request)

BFX90-...-ES-***-W1
BFX90-...-ES-***-W5

- * Kit including Metric bolts 8.8, spring rings, O-ring made of NBR (Buna-N®)
- * Kit including Metric bolts 8.8, spring rings, O-ring made of FKM/FPM (Viton®)
- * Kit including Metric bolts 10.9, spring rings, O-ring made of NBR (Buna-N®)
- * Kit including UNC bolts (Grade 8), spring rings, O-ring made of NBR (Buna-N®)

BFX90-...-ES-***-W46-K
BFX90-...-ES-***-V-W46-K
BFX90-...-ES-***-MH-W1-K
BFX90-...-ES-***-U-W1-K

Please always indicate ØB / ØA.



SAE 90° Single-Part Flange with Male Metric Thread and 24° Conical Bore (Shape W acc. to DIN 3861) ▪ Type BFX90-L/S ▪ 3000 PSI Series

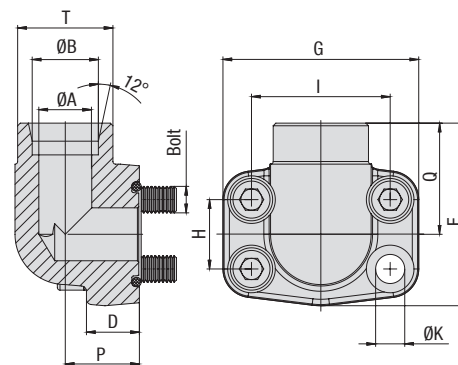

3000 PSI Standard Pressure Series (based on ISO 6162-1:2002)

Nominal Size		PN ¹ (bar/PSI)		Dimensions (mm/in)														Weight for Bolts (^{kg} /lbs) ca.		Ordering Codes
DN	(in)	8.8	10.9 (MH)	ØA	ØB	Series	D	F	G	H	I	P	Q	T (Metric)	ØK	per 100	Metric			
13	1/2	315	315	11	15	L	16	60	54	17,5	38,1	18	36	22x1,5	9	31,3	M8x30	BFX90-301-15L-W66		
		4568	4568	.43	.59		.63	2.36	2.13	.69	1.50	.71	1.42	.35	68.86					
13	1/2	350	350	12	16	S	16	60	54	17,5	38,1	18	36	24x1,5	9	29,4	M8x30	BFX90-301-16S-W66		
		5075	5075	.47	.63		.63	2.36	2.13	.69	1.50	.71	1.42	.35	64.68					
19	3/4	350	350	12	16	S	18	63	65	22,3	47,6	22	38	24x1,5	11	29,5	M10x35	BFX90-302-16S-W66		
		5075	5075	.47	.63		.71	2.48	2.56	.88	1.87	.87	1.50	.43	64.90					
19	3/4	350	350	16	20	S	18	63	65	22,3	47,6	22	38	30x2	11	43,8	M10x35	BFX90-302-20S-W66		
		5075	5075	.63	.79		.71	2.48	2.56	.88	1.87	.87	1.50	.43	96.36					
19	3/4	160	160	18	22	L	18	63	65	22,3	47,6	22	38	30x2	11	43,1	M10x35	BFX90-302-22L-W66		
		2320	2320	.71	.87		.71	2.48	2.56	.88	1.87	.87	1.50	.43	94.82					
25	1	250	315	20	25	S	19	70	70	26,2	52,4	28	42	36x2	11	62,5	M10x35	BFX90-303-25S-W66		
		3625	4568	.79	.98		.75	2.76	2.76	1.03	2.06	1.10	1.65	.43	137.50					
25	1	160	160	23	28	L	19	70	70	26,2	52,4	28	42	36x2	11	63,4	M10x35	BFX90-303-28L-W66		
		2320	2320	.91	1.10		.75	2.76	2.76	1.03	2.06	1.10	1.65	.43	139.48					
32	1-1/4	200	250	20	25	S	22	85	79	30,2	58,7	30	50	36x2	11,5	109,1	M10x40	BFX90-304-25S-W66		
		2900	3625	.79	.98		.87	3.35	3.11	1.19	2.31	1.18	1.97	.45	240.02					
32	1-1/4	200	250	25	30	S	22	85	79	30,2	58,7	30	50	42x2	11,5	103,4	M10x40	BFX90-304-30S-W66		
		2900	3625	.98	1.18		.87	3.35	3.11	1.19	2.31	1.18	1.97	.45	227.48					
32	1-1/4	160	160	30	35	L	22	85	79	30,2	58,7	30	50	45x2	11,5	89,9	M10x40	BFX90-304-35L-W66		
		2320	2320	1.18	1.38		.87	3.35	3.11	1.19	2.31	1.18	1.97	.45	197.78					
38	1-1/2	200	200	32	38	S	25	95	93	35,7	69,8	36	58	52x2	13,5	151,6	M12x45	BFX90-305-38S-W66		
		2900	2900	1.26	1.50		.98	3.74	3.66	1.41	2.75	1.42	2.28	.53	333.52					
38	1-1/2	160	160	36	42	L	25	95	93	35,7	69,8	36	58	52x2	13,5	141,3	M12x45	BFX90-305-42L-W66		
		2320	2320	1.42	1.65		.98	3.74	3.66	1.41	2.75	1.42	2.28	.53	310.96					

Materials / Ordering Options / Examples

- * SAE Single-Part Flange (without O-ring) made of Steel S355J0 / C45 or equivalent, zinc-plated and thick-film-passivated **BFX90-...-W66**
- * SAE Single-Part Flange (without O-ring) made of Stainless Steel V4A – 1.4404 (on request) **BFX90-...-W5**
- * Kit including Metric bolts 8.8, spring rings, O-ring made of NBR (Buna-N®) **BFX90-...-W66-K**
- * Kit including Metric bolts 8.8, spring rings, O-ring made of FKM/FPM (Viton®) **BFX90-...-V-W66-K**
- * Kit including Metric bolts 10.9, spring rings, O-ring made of NBR (Buna-N®) **BFX90-...-MH-W129-K**

Please always indicate ØB and Series.

¹ The maximum working pressure PN (bar/PSI) applies only to the flange itself and depends on the bolts used (Grade 8.8 / 10.9). The actual maximum working pressure depends on the thickness and the quality of the tube used.



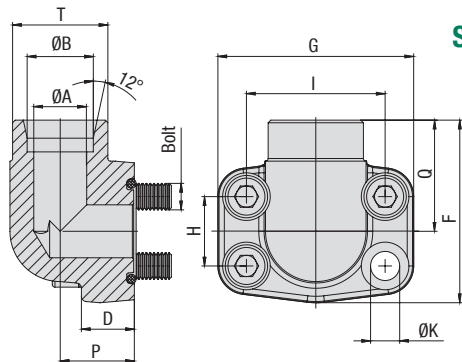

SAE 90° Single-Part Flange with Male Metric Thread and 24° Conical Bore (Shape W acc. to DIN 3861) ▪ Type BFX90-L/S ▪ 6000 PSI Series



6000 PSI High Pressure Series (based on ISO 6162-2:2002)

C

Nominal Size		PN ¹ (bar/PSI)		Dimensions (mm/in)			Weight (kg/lbs) Ca.		for Bolts		Ordering Codes							
DN	(in)	8.8	10.9 (MH)	ØA	ØB	Series	D	F	G	H		I	P	Q	T (Metric)	ØK	per 100	Metric
13	1/2	350	420	12	16	S	16	60	54	18,2	40,5	20	36	24x1,5	9	29,8	M8x30	BFX90-601-16S-W66
		5075	6090	.47	.63		.63	2.36	2.13	.72	1.59	.79	1.42		.35	65.56		
19	3/4	350	420	12	16	S	19	70	72	23,8	50,8	26	41	24x1,5	11	64,3	M10x35	BFX90-602-16S-W66
		5075	6090	.47	.63		.75	2.76	2.83	.94	2.00	1.02	1.61		.43	141.46		
19	3/4	350	400	20	20	S	19	70	72	23,8	50,8	26	41	30x2	11	66,5	M10x35	BFX90-602-20S-W66
		5075	5800	.79	.79		.75	2.76	2.83	.94	2.00	1.02	1.61		.43	146.30		
25	1	350	400	20	25	S	24	85	79	27,8	57,2	30	50	36x2	13	106,3	M12x40	BFX90-603-25S-W66 ²
		5075	5800	.79	.98		.94	3.35	3.11	1.09	2.25	1.18	1.97		.51	233.86		
32	1-1/4	350	400	25	30	S	25	95	93	31,8	66,6	36	58	42x2	15	159,5	M14x45	BFX90-604-30S-M14-W66
		5075	5800	.98	1.18		.98	3.74	3.66	1.25	2.62	1.42	2.28		.59	350.90		
38	1-1/2	350	350	32	38	S	26	110	110	36,5	79,3	41	65	52x2	17	240,2	M16x50	BFX90-605-38S-W66
		5075	5075	1.26	1.50		1.02	4.33	4.33	1.44	3.12	1.61	2.56		.67	528.44		

¹ The maximum working pressure PN (bar/PSI) applies only to the flange itself and depends on the bolts used (Grade 8.8 / 10.9). The actual maximum working pressure depends on the thickness and the quality of the tube used.

² For UNC threaded bolts, use hexagon head bolts only. Please note that these do not belong to our product range.

Materials / Ordering Options / Examples

- * SAE Single-Part Flange (without O-ring) made of Steel S355J0 / C45 or equivalent, blank (oiled) zinc-plated and thick-film-passivated BFX90-...-...-W66
- * SAE Single-Part Flange (without O-ring) made of Stainless Steel V4A – 1.4404 (on request) BFX90-...-...-W5
- * Kit including Metric bolts 8.8, spring rings, O-ring made of NBR (Buna-N®) BFX90-...-...-W66-K
- * Kit including Metric bolts 8.8, spring rings, O-ring made of FKM/FPM (Viton®) BFX90-...-...-V-W66-K
- * Kit including Metric bolts 10.9, spring rings, O-ring made of NBR (Buna-N®) BFX90-...-...-MH-W129-K

Please always indicate ØB and Series.





	SAE Single-Part Blanking Flange BFX-CP	82
	SAE Single-Part Blanking Counterflange BAS-CP	83
	SAE Sandwich Plate with Female BSPP Port SPL-G04-L	84
	SAE Blindplug (Standard) CAG-BP	85
	SAE Blindplug (High) CAG-BPH	85
	SAE Sandwich Plate SPL	86
	SAE Cover Plate CPL	87
	SAE Reducing Flange BFX-BAS	88
	Separate Bolt Sets and Sealings	89

D

SAE Single-Part Blanking Flange
Type BFX-CP ▪ 3000 / 6000 PSI Series

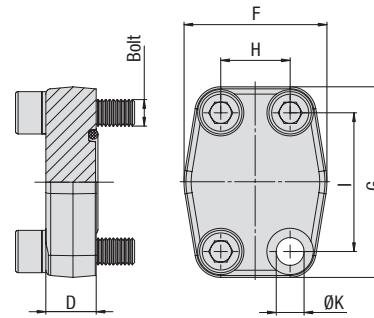

3000 PSI Standard Pressure Series (based on ISO 6162-1:2002)

Nominal Size		PN ¹ (bar/PSI)		Dimensions (mm/in)						Weight (kg/lbs) ca. per 100	for Bolts		Ordering Codes
DN	(in)	8.8	10.9 (MH)	D	F	G	H	I	ØK ³		Metric ³	UNC	
13	1/2	350	350	16	47	57	17,5	38,1	8,7	22,3	M8x30	5/16-18 UNC x 1-1/4	BFX-301-CP-W1
		5075	5075	.63	1.85	2.24	.69	1.50	.34	49.06			
19	3/4	350	350	18	50	67	22,3	47,6	10,5	34,1	M10x35	3/8-16 UNC x 1-1/2	BFX-302-CP-W1
		5075	5075	.71	1.97	2.64	.88	1.87	.41	75.02			
25	1	250	315	19	54	72	26,2	52,4	10,5	39,9	M10x35	3/8-16 UNC x 1-1/2	BFX-303-CP-W1
		3625	4568	.75	2.13	2.83	1.03	2.06	.41	87.78			
32	1-1/4	200	250	18	68	82	30,2	58,7	11,5 (13,5)	56,3	M10x40 (M12x40)	7/16-14 UNC x 1-1/2	BFX-304-CP-W1
		2900	3625	.71	2.68	3.23	1.19	2.31	.45 (.53)	123.86			
38	1-1/2	200	200	20	79	96	35,7	69,9	13,5 (14,5)	89,7	M12x45 (M14x45)	1/2-13 UNC x 1-3/4	BFX-305-CP-W1
		2900	2900	.79	3.11	3.78	1.41	2.75	.53 (.57)	197.34			
51	2	160	200	20	88	102	42,9	77,8	13,5 (14,5)	105,7	M12x45 (M14x45)	1/2-13 UNC x 1-3/4	BFX-306-CP-W1
		2320	2900	.79	3.46	4.02	1.69	3.06	.53 (.57)	232.54			
64	2-1/2	100	160	20	101	115	50,8	88,9	13,5 (14,5)	141,5	M12x45 (M14x45)	1/2-13 UNC x 1-3/4	BFX-307-CP-W1
		1450	2320	.79	3.98	4.53	2.00	3.50	.53 (.57)	311.27			
76	3	100	160	24	127	137	61,9	106,4	17	237,7	M16x50	5/8-11 UNC x 2	BFX-308-CP-W1
		1450	2320	.94	5.00	5.39	2.44	4.19	.67	522.94			
89	3-1/2	35	35	22	138	155	69,8	120,7	17	280,5	M16x50	5/8-11 UNC x 2	BFX-309-CP-W1
		508	508	.87	5.43	6.10	2.75	4.75	.67	617.10			
102	4	35	35	25	147	163	77,8	130,2	17	382,6	M16x50	5/8-11 UNC x 2	BFX-310-CP-W1
		508	508	.98	5.79	6.42	3.06	5.13	.67	841.72			
127	5	35	35	25	180	184	92	152,4	17	582,0	M16x55	5/8-11 UNC x 2-1/4	BFX-311-CP-W1
		508	508	.98	7.09	7.24	3.62	6.00	.67	1280.40			

6000 PSI High Pressure Series (based on ISO 6162-2:2002)

Nominal Size		PN ¹ (bar/PSI)		Dimensions (mm/in)						Weight (kg/lbs) ca. per 100	for Bolts		Ordering Codes
DN	(in)	8.8	10.9 (MH)	D	F	G	H	I	ØK ³		Metric	UNC	
13	1/2	350	420	16	47	57	18,2	40,5	8,7	22,3	M8x30	5/16-18 UNC x 1-1/4	BFX-601-CP-W1
		5075	6090	.63	1.85	2.24	.72	1.59	.34	49.06			
19	3/4	350	420	19	54	72	23,8	50,8	10,5	44,0	M10x35	3/8-16 UNC x 1-1/2	BFX-602-CP-W1
		5075	6090	.75	2.13	2.83	.94	2.00	.41	96.80			
25	1	350	420	24	68	82	27,8	57,2	13	74,8	M12x45	7/16-14 UNC x 1-3/4	BFX-603-CP-W1 ²
		5075	6090	.94	2.68	3.23	1.09	2.25	.51	164.56			
32	1-1/4	350	420	27	79	95	31,8	66,6	13,5	117,3	M12x45	1/2-13 UNC x 1-3/4	BFX-604-CP-W1
		5075	6090	1.06	3.11	3.74	1.25	2.62	.53	258.06			
32	1-1/4	350	420	27	79	95	31,8	66,6	15	118,0	M14x45	/	BFX-604-CP-M14-W1
		5075	6090	1.06	3.11	3.74	1.25	2.62	.59	259.60			
38	1-1/2	350	420	30	88	108	36,5	79,3	17	155,0	M16x55	5/8-11 UNC x 2-1/4	BFX-605-CP-W1
		5075	6090	1.18	3.46	4.25	1.44	3.12	.67	341.00			
51	2	350	420	30	118	137	44,5	96,8	21	267,2	M20x65	3/4-10 UNC x 2-3/4	BFX-606-CP-W1
		5075	6090	1.18	4.65	5.39	1.75	3.81	.83	587.84			
64	2-1/2	350	420	45	152	180	58,7	123,8	26	758,4	M24x80	/	BFX-607-CP-W1
		5075	6090	1.77	5.98	7.09	2.31	4.87	1.02	1668.48			
76	3	350	420	55	178	208	71,4	152,4	33	1201,8	M30x100	/	BFX-608-CP-W1
		5075	6090	2.17	7.01	8.19	2.81	6.00	1.30	2643.96			

Materials / Ordering Options / Examples

- * SAE Single-Part Blanking Flange (without O-ring) made of Steel S355J0 / C45 or equivalent, blank (oiled)
- * SAE Single-Part Blanking Flange (without O-ring) made of Stainless Steel V4A – 1.4404 (on request)
- * Kit including Metric bolts 8.8, spring rings, O-ring made of NBR (Buna-N®)
- * Kit including Metric bolts 8.8, spring rings, O-ring made of FKM/FPM (Viton®)
- * Kit including Metric bolts 10.9, spring rings, O-ring made of NBR (Buna-N®)
- * Kit including UNC bolts (Grade 8), spring rings, O-ring made of NBR (Buna-N®)

- BFX-...-CP-W1**
- BFX-...-CP-W5**
- BFX-...-CP-W46-K**
- BFX-...-CP-V-W46-K**
- BFX-...-CP-MH-W1-K**
- BFX-...-CP-U-W1-K**

¹ The maximum working pressure PN (bar/PSI) applies only to the flange itself and depends on the bolts used (Grade 8.8 / 10.9). The actual maximum working pressure depends on the thickness and the quality of the tube used.

² For UNC threaded bolts, use hexagon head bolts only. Please note that these do not belong to our product range.

³ Alternative options shown in brackets are available on request.



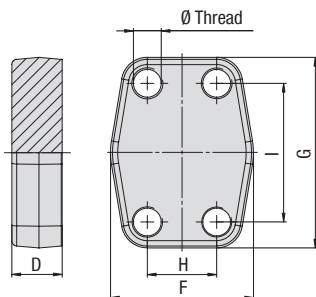

SAE Single-Part Blanking Counterflange Type BAS-CP • 3000 / 6000 PSI Series



3000 PSI Standard Pressure Series (based on ISO 6162-1:2002)

Nominal Size DN	(in)	PN ¹ (bar/PSI)		Dimensions (mm/in)					Weight (kg/lbs) ca. per 100	for Bolts		Ordering Codes
		8.8	10.9 (MH)	D	F	G	H	I		Metric ³	UNC	
13	1/2	350	350	16	47	57	17,5	38,1	25,2	M8	5/16-18 UNC	BAS-301-CP-W1
		5075	5075	.63	1.85	2.24	.69	1.50	55.44			
19	3/4	350	350	18	50	67	22,3	47,6	31,9	M10	3/8-16 UNC	BAS-302-CP-W1
		5075	5075	.71	1.97	2.64	.88	1.87	70.18			
25	1	250	315	19	54	72	26,2	52,4	49,1	M10	3/8-16 UNC	BAS-303-CP-W1
		3625	4568	.75	2.13	2.83	1.03	2.06	108.02			
32	1-1/4	200	250	18	68	82	30,2	58,7	60,0	M10 (M12)	7/16-14 UNC	BAS-304-CP-W1
		2900	3625	.71	2.68	3.23	1.19	2.31	132.00			
38	1-1/2	200	200	20	79	96	35,7	69,9	83,4	M12 (M14)	1/2-13 UNC	BAS-305-CP-W1
		2900	2900	.79	3.11	3.78	1.41	2.75	183.48			
51	2	160	200	20	88	102	42,9	77,8	110,6	M12 (M14)	1/2-13 UNC	BAS-306-CP-W1
		2320	2900	.79	3.46	4.02	1.69	3.06	243.32			
64	2-1/2	100	160	20	101	115	50,8	88,9	145,2	M12 (M14)	1/2-13 UNC	BAS-307-CP-W1
		1450	2320	.79	3.98	4.53	2.00	3.50	319.44			
76	3	100	160	24	127	137	61,9	106,4	252,4	M16	5/8-11 UNC	BAS-308-CP-W1
		1450	2320	.94	5.00	5.39	2.44	4.19	555.28			
89	3-1/2	35	35	22	138	155	69,8	120,7	292,8	M16	5/8-11 UNC	BAS-309-CP-W1
		508	508	.87	5.43	6.10	2.75	4.75	644.16			
102	4	35	35	25	147	163	77,8	130,2	379,6	M16	5/8-11 UNC	BAS-310-CP-W1
		508	508	.98	5.79	6.42	3.06	5.13	835.12			
127	5	35	35	25	180	184	92	152,4	586,3	M16	5/8-11 UNC	BAS-311-CP-W1
		508	508	.98	7.09	7.24	3.62	6.00	1289.86			

6000 PSI High Pressure Series (based on ISO 6162-2:2002)

Nominal Size DN	(in)	PN ¹ (bar/PSI)		Dimensions (mm/in)					Weight (kg/lbs) ca. per 100	for Bolts		Ordering Codes
		8.8	10.9 (MH)	D	F	G	H	I		Metric	UNC	
13	1/2	350	420	16	47	57	18,2	40,5	25,6	M8	5/16-18 UNC	BAS-601-CP-W1
		5075	6090	.63	1.85	2.24	.72	1.59	56.32			
19	3/4	350	420	19	54	72	23,8	50,8	49,0	M10	3/8-16 UNC	BAS-602-CP-W1
		5075	6090	.75	2.13	2.83	.94	2.00	107.80			
25	1	350	420	24	68	82	27,8	57,2	79,5	M12	7/16-14 UNC	BAS-603-CP-W1
		5075	6090	.94	2.68	3.23	1.09	2.25	174.90			
32	1-1/4	350	420	27	79	95	31,8	66,6	122,4	M12	1/2-13 UNC	BAS-604-CP-W1
		5075	6090	1.06	3.11	3.74	1.25	2.62	269.28			
32	1-1/4	350	420	27	79	95	31,8	66,6	114,9	M14		BAS-604-CP-M14-W1
		5075	6090	1.06	3.11	3.74	1.25	2.62	252.78			
38	1-1/2	350	420	30	88	108	36,5	79,3	185,1	M16	5/8-11 UNC	BAS-605-CP-W1
		5075	6090	1.18	3.46	4.25	1.44	3.12	407.22			
51	2	350	420	30	118	137	44,5	96,8	266,7	M20	3/4-10 UNC	BAS-606-CP-W1
		5075	6090	1.18	4.65	5.39	1.75	3.81	586.74			
64	2-1/2	350	420	45	152	180	58,7	123,8	774,6	M24		BAS-607-CP-W1
		5075	6090	1.77	5.98	7.09	2.31	4.87	1704.12			
76	3	350	420	55	178	208	71,4	152,4	737,4	M30		BAS-608-CP-W1
		5075	6090	2.17	7.01	8.19	2.81	6.00	1622.28			

¹ The maximum working pressure PN (bar/PSI) applies only to the flange itself and depends on the bolts used (Grade 8.8 / 10.9). The actual maximum working pressure depends on the thickness and the quality of the tube used.

³ Alternative options shown in brackets are available on request.

Materials / Ordering Options / Examples

- * SAE Single-Part Blanking Counterflange made of Steel S355J0 or equivalent, blank (oiled) with Metric tapped holes BAS-...-CP-W1
- * SAE Single-Part Blanking Counterflange made of Stainless Steel V4A – 1.4404 (on request) with Metric tapped holes BAS-...-CP-W5
- * SAE Single-Part Blanking Counterflange made of Steel S355J0 or equivalent, blank (oiled) with size of Metric tapped holes deviating from the standard (e.g. M14) BAS-...-CP-M14-W1
- * SAE Single-Part Blanking Counterflange made of Steel S355J0 or equivalent, blank (oiled) with UNC tapped holes BAS-...-CP-U-W1



**SAE Sandwich Plate with Female BSPP Port
Type SPL-G04-L - 3000 / 6000 PSI Series**

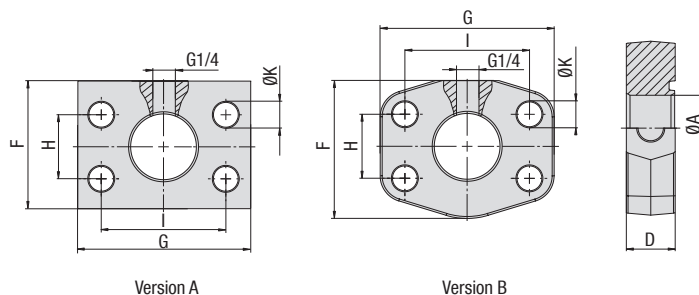

3000 PSI Standard Pressure Series (based on ISO 6162-1:2002)

Nominal Size		PN ¹ (bar/PSI)		Dimensions (mm/in)							Version	Weight (kg/lbs) ca. per 100	Ordering Codes
DN	(in)	8.8	10.9 (MH)	ØA	D	F	G	H	I	ØK			
13	1/2	350	350	12	24	40	55	17,5	38,1	8,7	A	30,8	SPL-301-G04-L-W1
		5075	5075	.47	.94	1.57	2.17	.69	1.50	.34		67.76	
19	3/4	350	350	19	28	50	65	22,3	47,6	10,5	A	52,3	SPL-302-G04-L-W1
		5075	5075	.75	1.10	1.97	2.56	.88	1.87	.41		115.06	
25	1	250	315	24	25	60	70,6	26,2	52,4	10,5	B	51,2	SPL-303-G04-L-W1
		3625	4568	.94	.98	2.36	2.78	1.03	2.06	.41		112.64	
32	1-1/4	200	250	31	23	68	82	30,2	58,7	11,5	B	56,4	SPL-304-G04-L-W1
		2900	3625	1.22	.91	2.68	3.23	1.19	2.31	.45		124.08	
38	1-1/2	200	200	38	24	79	96	35,7	69,9	13,5	B	86,2	SPL-305-G04-L-W1
		2900	2900	1.50	.94	3.11	3.78	1.41	2.75	.53		189.64	
51	2	160	200	50	24	88	102	42,9	77,8	13,5	B	93,2	SPL-306-G04-L-W1
		2320	2900	1.97	.94	3.46	4.02	1.69	3.06	.53		205.04	

6000 PSI High Pressure Series (based on ISO 6162-2:2002)

Nominal Size		PN ¹ (bar/PSI)		Dimensions (mm/in)							Version	Weight (kg/lbs) ca. per 100	Ordering Codes
DN	(in)	8.8	10.9 (MH)	ØA	D	F	G	H	I	ØK			
13	1/2	350	420	12	24	40	55	18,2	40,5	8,7	A	29,0	SPL-601-G04-L-W1
		5075	6090	.47	.94	1.57	2.17	.72	1.59	.34		63.80	
19	3/4	350	420	19	25	60	70,6	23,8	50,8	10,5	A	53,1	SPL-602-G04-L-W1
		5075	6090	.75	.98	2.36	2.78	.94	2.00	.41		116.82	
25	1	350	420	25	23	68	82	27,8	57,2	13	B	60,3	SPL-603-G04-L-W1
		5075	6090	.98	.91	2.68	3.23	1.09	2.25	.51		132.66	
32	1-1/4	350	420	31	25	79	95	31,8	66,6	13,5	B	94,2	SPL-604-G04-L-W1
		5075	6090	1.22	.98	3.11	3.74	1.25	2.62	.53		207.24	
32	1-1/4	350	420	31	25	79	95	31,8	66,6	15	B	89,2	SPL-604-G04-L-M14-W1
		5075	6090	1.22	.98	3.11	3.74	1.25	2.62	.59		196.24	
38	1-1/2	350	420	38	28	88	108	36,5	79,3	17	B	147,3	SPL-605-G04-L-W1
		5075	6090	1.50	1.10	3.46	4.25	1.44	3.12	.67		324.06	
51	2	350	420	50	33	118	137	44,5	96,8	21	B	268,6	SPL-606-G04-L-W1
		5075	6090	1.97	1.30	4.65	5.39	1.75	3.81	.83		590.92	

Materials / Ordering Options / Examples

- * SAE Sandwich Plate with Female BSPP Port (without O-ring)
made of Steel S355J0 / C45 or equivalent, blank (oiled) **SPL-....-G04-L-W1**
- * SAE Sandwich Plate with Female BSPP Port (without O-ring)
made of Stainless Steel V4A – 1.4404 (on request) **SPL-....-G04-L-W5**

Use the female BSPP port of the SAE Sandwich Plate to permanently install a pressure sensor, a hydraulic test coupling or any sort of diagnostic equipment in your hydraulic system. Contact STAUFF for details.

¹ The maximum working pressure PN (bar/PSI) applies only to the flange itself and depends on the bolts used (Grade 8.8 / 10.9).



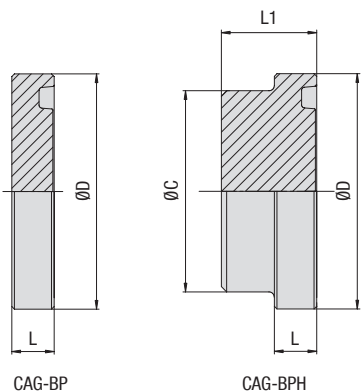

SAE Blindplug Type CAG-BP (Standard) / CAG-BPH (High) • 3000 / 6000 PSI Series



3000 PSI Standard Pressure Series (based on ISO 6162-1:2002)

Nominal Size		PN (^{bar/PSI})		Dimensions (^{mm/in})				Weight (^{kg/lbs}) ca. per 100		Ordering Codes	Ordering Codes
DN	(in)	BP	BPH	ØC	ØD	L	L1	CAG-BP	CAG-BPH		
13	1/2	210	350	24	30,2	6,8	15	3,1	6,0	CAG-BP-301-W66	CAG-BPH-301-W66
		3045	5075	.94	1.19	.27	.59	6.82	13.20		
19	3/4	210	350	31,5	38,1	6,8	16	5,2	11,0	CAG-BP-302-W66	CAG-BPH-302-W66
		3045	5075	1.24	1.50	.27	.63	11.44	24.20		
25	1	210	315	38	44,45	8	18	8,9	17,9	CAG-BP-303-W66	CAG-BPH-303-W66
		3045	4568	1.50	1.75	.31	.71	19.58	39.38		
32	1-1/4	200	250	43	50,8	8	18	11,2	23,3	CAG-BP-304-W66	CAG-BPH-304-W66
		2900	3625	1.69	2.00	.31	.71	24.64	51.26		
38	1-1/2	160	200	50	60,35	8	18	16,2	32,2	CAG-BP-305-W66	CAG-BPH-305-W66
		2320	2900	1.97	2.38	.31	.71	35.64	70.84		
51	2	160	200	61,8	71,4	9,6	21	27,9	56,1	CAG-BP-306-W66	CAG-BPH-306-W66
		2320	2900	2.43	2.81	.38	.83	61.38	123.42		
64	2-1/2	100	160	73,8	84,1	9,6	21	39,2	78,0	CAG-BP-307-W66	CAG-BPH-307-W66
		1450	2320	2.91	3.31	.38	.83	86.24	171.60		
76	3	100	160	90	101,6	9,6	24	57,8	235,2	CAG-BP-308-W66	CAG-BPH-308-W66
		1450	2320	3.54	4.00	.38	.94	127.16	517.44		
89	3-1/2	35	35	102	114,3	11,3	45	86,2	303,1	CAG-BP-309-W66	CAG-BPH-309-W66
		508	508	4.02	4.50	.44	1.77	189.64	666.82		
102	4	35	35	114	127	11,3	55	107,4	458,8	CAG-BP-310-W66	CAG-BPH-310-W66
		508	508	4.49	5.00	.44	2.17	236.28	1009.28		

6000 PSI High Pressure Series (based on ISO 6162-2:2002)

Nominal Size		PN (^{bar/PSI})		Dimensions (^{mm/in})				Weight (^{kg/lbs}) ca. per 100		Ordering Codes	Ordering Codes
DN	(in)	BP	BPH	ØC	ØD	L	L1	CAG-BP	CAG-BPH		
13	1/2	250	350	24	31,8	7,8	18	4,0	8,4	CAG-BP-601-W66	CAG-BPH-601-W66
		3625	5075	.94	1.25	.31	.71	8.80	18.48		
19	3/4	250	350	32	41,3	8,8	21	8,6	16,3	CAG-BP-602-W66	CAG-BPH-602-W66
		3625	5075	1.26	1.63	.35	.83	18.92	35.86		
25	1	250	350	38	47,6	9,5	26	12,4	26,9	CAG-BP-603-W66	CAG-BPH-603-W66
		3625	5075	1.50	1.87	.37	1.02	27.28	59.18		
32	1-1/4	250	350	43,8	54	10,3	31	17,7	42,2	CAG-BP-604-W66 ²	CAG-BPH-604-W66 ²
		3625	5075	1.72	2.13	.41	1.22	38.94	92.84		
38	1-1/2	250	350	50,8	63,5	12,6	34	29,5	64,6	CAG-BP-605-W66	CAG-BPH-605-W66
		3625	5075	2.00	2.50	.50	1.34	64.90	142.12		
51	2	250	350	66,5	79,4	12,6	42	47,1	129,4	CAG-BP-606-W66	CAG-BPH-606-W66
		3625	5075	2.62	3.13	.50	1.65	103.62	284.68		
64	2-1/2	250	350	89	108	21,2	45		265,6		CAG-BPH-607-W66
		3625	5075	3.50	4.25	.83	1.77		584.32		

² According to ISO 6162-2 bolts M12 should be used but because usually bolts M14 are used the description of the complete part must show M14 (e.g. CAG-BP-604-M14-W66-K).

Materials / Ordering Options / Examples

- * SAE Blindplug (without O-ring) made of Steel S355J0 / C45 or equivalent, zinc-plated and thick-film-passivated **CAG-BP-...-W66**
- * SAE Blindplug (without O-ring) made of Stainless Steel V4A – 1.4404 (on request) **CAG-BP-...-W5**
- * SAE Counterflange Blindplug made of Steel S355J0 / C45 or equivalent, zinc-plated and thick-film-passivated **CSG-BP-...-W66**

- * Kit with DB including Metric bolts 8.8, spring rings, O-ring made of NBR (Buna-N®) **CAG-BP-...-W66-K**
- * Kit with DB including Metric bolts 8.8, spring rings, O-ring made of FKM/FPM (Viton®) **CAG-BP-...-V-W66-K**
- * Kit with DB including Metric bolts 10.9, spring rings, O-ring made of NBR (Buna-N®) **CAG-BP-...-MH-W130-K**
- * Kit with DB including UNC bolts (Grade 8), spring rings, O-ring made of NBR (Buna-N®) **CAG-BP-...-U-W130-K**
- * Kit with BM including Metric bolts 8.8, spring rings, O-ring made of NBR (Buna-N®) **CAG-BP-...-BM-W66-K**



SAE Sandwich Plate
Type SPL - 3000 / 6000 PSI Series

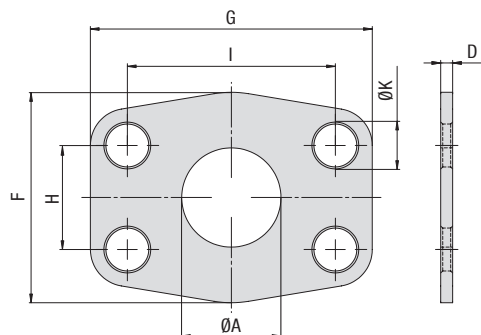

3000 PSI Standard Pressure Series (based on ISO 6162-1:2002)

Nominal Size		Dimensions (mm/in)							Weight (kg/lbs) ca. per 100	Ordering Codes
DN	(in)	ØA	D	F	G	H	I	ØK		
13	1/2	13	3	47	57	17,5	38,1	9	4,1	SPL-301-W1
		.51	.12	1.85	2.24	.69	1.50	.35	9.02	
19	3/4	19	3	49	66	22,3	47,6	11	5,1	SPL-302-W1
		.75	.12	1.93	2.60	.88	1.87	.43	11.22	
25	1	25	3	53	71	26,2	52,4	11	5,7	SPL-303-W1
		.98	.12	2.09	2.80	1.03	2.06	.43	12.54	
32	1-1/4	32	3	69	80	30,2	58,7	11,5	8,2	SPL-304-W1
		1.26	.12	2.72	3.15	1.19	2.31	.45	18.04	
38	1-1/2	38	3	77	95	35,7	69,9	13,5	10,5	SPL-305-W1
		1.50	.12	3.03	3.74	1.41	2.75	.53	23.10	
51	2	51	3	89	103	42,9	77,8	13,5	12,3	SPL-306-W1
		2.01	.12	3.50	4.06	1.69	3.06	.53	27.06	
64	2-1/2	63	3	101	116	50,8	88,9	13,5	14,2	SPL-307-W1
		2.48	.12	3.98	4.57	2.00	3.50	.53	31.24	
76	3	73	4	124	136	61,9	106,4	17	27,3	SPL-308-W1
		2.87	.16	4.88	5.35	2.44	4.19	.67	60.06	
89	3-1/2	89	4	136	152	69,8	120,7	17	33,2	SPL-309-W1
		3.50	.16	5.35	5.98	2.75	4.75	.67	73.04	
102	4	99	4	146	162	77,8	130,2	17	36,5	SPL-310-W1
		3.90	.16	5.75	6.38	3.06	5.13	.67	80.30	
127	5	120	4	180	184	92	152,4	17	49,7	SPL-311-W1
		4.72	.16	7.09	7.24	3.62	6.00	.67	109.34	

6000 PSI High Pressure Series (based on ISO 6162-2:2002)

Nominal Size		Dimensions (mm/in)							Weight (kg/lbs) ca. per 100	Ordering Codes
DN	(in)	ØA	D	F	G	H	I	ØK		
13	1/2	13	4	47	57	18,2	40,5	9	5,6	SPL-601-W1
		.51	.16	1.85	2.24	.72	1.59	.35	12.32	
19	3/4	17	4	53	71	23,8	50,8	11	8,0	SPL-602-W1
		.67	.16	2.09	2.80	.94	2.00	.43	17.60	
25	1	24	4	66	80	27,8	57,2	13	10,9	SPL-603-W1
		.94	.16	2.60	3.15	1.09	2.25	.51	23.98	
32	1-1/4	31	4	77	94	31,8	66,6	15	14,6	SPL-604-M14-W1
		1.22	.16	3.03	3.70	1.25	2.62	.59	32.12	
38	1-1/2	38	4	89	103	36,5	79,3	17	18,1	SPL-605-W1
		1.50	.16	3.50	4.06	1.44	3.12	.67	39.82	
51	2	51	4	116	135	44,5	96,8	21	29,3	SPL-606-W1
		2.01	.16	4.57	5.31	1.75	3.81	.83	64.46	
64	2-1/2	63	4	150	166	58,7	123,8	25	48,1	SPL-607-W1
		2.48	.16	5.91	6.54	2.31	4.87	.98	105.82	
76	3	73	4	178	208	71,4	152,4	32	71,5	SPL-608-W1
		2.87	.16	7.01	8.19	2.81	6.00	1.26	157.30	

Materials / Ordering Options / Examples

* SAE Sandwich Plate made of Steel ST35 or equivalent, blank (oiled)

SPL-...-W1



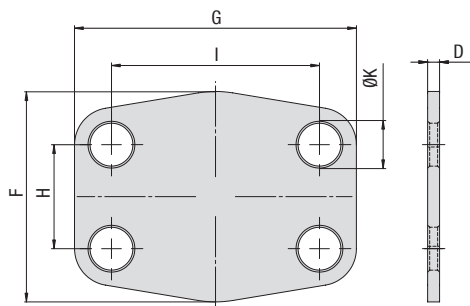

SAE Cover Plate Type CPL - 3000 / 6000 PSI Series



3000 PSI Standard Pressure Series (based on ISO 6162-1:2002)

Nominal Size		Dimensions (mm/in)						Weight (kg/lbs) ca. per 100	Ordering Codes
DN	(in)	D	F	G	H	I	ØK		
13	1/2	3	47	57	17,5	38,1	9	4,3	CPL-301-W1
		.12	1.85	2.24	.69	1.50	.35	9.46	
19	3/4	3	49	66	22,3	47,6	11	5,7	CPL-302-W1
		.12	1.93	2.60	.88	1.87	.43	12.54	
25	1	3	53	71	26,2	52,4	11	6,9	CPL-303-W1
		.12	2.09	2.80	1.03	2.06	.43	15.18	
32	1-1/4	3	69	80	30,2	58,7	11,5	9,7	CPL-304-W1
		.12	2.72	3.15	1.19	2.31	.45	21.34	
38	1-1/2	3	77	95	35,7	69,9	13,5	12,8	CPL-305-W1
		.12	3.03	3.74	1.41	2.75	.53	28.16	
51	2	3	89	103	42,9	77,8	13,5	16,5	CPL-306-W1
		.12	3.50	4.06	1.69	3.06	.53	36.30	
64	2-1/2	3	101	116	50,8	88,9	13,5	22,3	CPL-307-W1
		.12	3.98	4.57	2.00	3.50	.53	49.06	
76	3	4	124	136	61,9	106,4	17	40,3	CPL-308-W1
		.16	4.88	5.35	2.44	4.19	.67	88.66	
89	3-1/2	4	136	152	69,8	120,7	17	53,3	CPL-309-W1
		.16	5.35	5.98	2.75	4.75	.67	117.26	
102	4	4	146	162	77,8	130,2	17	61,1	CPL-310-W1
		.16	5.75	6.38	3.06	5.13	.67	134.42	
127	5	4	180	184	92	152,4	17	85,5	CPL-311-W1
		.16	7.09	7.24	3.62	6.00	.67	188.10	

6000 PSI High Pressure Series (based on ISO 6162-2:2002)

Nominal Size		Dimensions (mm/in)						Weight (kg/lbs) ca. per 100	Ordering Codes
DN	(in)	D	F	G	H	I	ØK		
13	1/2	4	47	57	18,2	40,5	9	6,0	CPL-601-W1
		.16	1.85	2.24	.72	1.59	.35	13.20	
19	3/4	4	53	71	23,8	50,8	11	9,0	CPL-602-W1
		.16	2.09	2.80	.94	2.00	.43	19.80	
25	1	4	66	80	27,8	57,2	13	12,8	CPL-603-W1
		.16	2.60	3.15	1.09	2.25	.51	28.16	
32	1-1/4	4	77	94	31,8	66,6	15	16,7	CPL-604-M14-W1
		.16	3.03	3.70	1.25	2.62	.59	36.74	
38	1-1/2	4	89	103	36,5	79,3	17	21,8	CPL-605-W1
		.16	3.50	4.06	1.44	3.12	.67	47.96	
51	2	4	116	135	44,5	96,8	21	36,6	CPL-606-W1
		.16	4.57	5.31	1.75	3.81	.83	80.52	
64	2-1/2	4	150	166	58,7	123,8	25	57,6	CPL-607-W1
		.16	5.91	6.54	2.31	4.87	.98	126.72	
76	3	4	178	208	71,4	152,4	32	85,6	CPL-608-W1
		.16	7.01	8.19	2.81	6.00	1.26	188.32	

Materials / Ordering Options / Examples

* SAE Cover Plate made of Steel ST35 or equivalent, blank (oiled)

CPL-...-W1



SAE Reducing Flange
Type BFX-...-BAS-... - 3000 / 6000 PSI Series

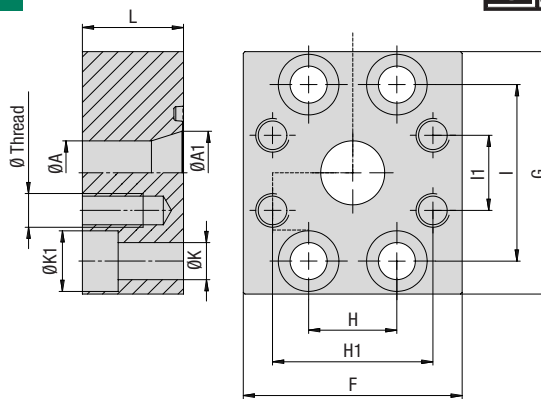

3000 PSI Standard Pressure Series (based on ISO 6162-1:2002)

Nominal Size		Dimensions (mm/in)										Weight	for Bolts	Ø Thread	Ordering Codes	
DN	(in)	ØA	ØA1	F	G	H	H1	I	I1	L	ØK	ØK1	per 100	Metric	Metric	
25	1	19	25	65	72	26,2	47,6	52,4	22,3	30	11	18	83,0	M10x30	M10	BFX-303-BAS-302-W1
		.75	.98	2.56	2.83	1.03	1.87	2.06	.88	1.18	.43	.71	182.60			
32	1-1/4	25	32	70	80	30,2	52,4	58,7	26,2	30	11	18	99,0	M10x30	M10	BFX-304-BAS-303-W1
		.98	1.26	2.76	3.15	1.19	2.06	2.31	1.03	1.18	.43	.71	217.80			
38	1-1/2	32	38	80	95	35,7	58,7	69,9	30,2	30	13,5	20	133,0	M12x35	M10	BFX-305-BAS-304-W1
		1.26	1.50	3.15	3.74	1.41	2.31	2.75	1.19	1.18	.53	.79	292.60			
51	2	32	51	95	100	42,9	58,7	77,8	30,2	30	13,5	20	165,6	M12x35	M10	BFX-306-BAS-304-W1
		1.26	2.01	3.74	3.94	1.69	2.31	3.06	1.19	1.18	.53	.79	364.32			
51	2	38	46	95	120	42,9	69,9	77,8	35,7	30	13,5	20	166,0	M12x35	M12	BFX-306-BAS-305-W1
		1.50	1.81	3.74	4.72	1.69	2.75	3.06	1.41	1.18	.53	.79	365.20			
64	2-1/2	38	62	109	114	50,8	69,9	88,9	35,7	35	13,5	20	257,0	M12x40	M12	BFX-307-BAS-305-W1
		1.50	2.44	4.29	4.49	2.00	2.75	3.50	1.41	1.38	.53	.79	565.40			
64	2-1/2	51	64	109	114	50,8	77,8	88,9	42,9	35	13,5	20	244,0	M12x40	M12	BFX-307-BAS-306-W1
		2.01	2.52	4.29	4.49	2.00	3.06	3.50	1.69	1.38	.53	.79	536.80			
76	3	51	76	114	140	61,9	77,8	106,4	42,9	40	17,5	26	367,4	M16x50	M12	BFX-308-BAS-306-W1
		2.01	2.99	4.49	5.51	2.44	3.06	4.19	1.69	1.57	.69	1.02	808.28			
76	3	64	76	114	140	61,9	88,9	106,4	50,8	40	17,5	26	367,0	M16x50	M12	BFX-308-BAS-307-W1
		2.52	2.99	4.49	5.51	2.44	3.50	4.19	2.00	1.57	.69	1.02	807.40			

6000 PSI High Pressure Series (based on ISO 6162-2:2002)

Nominal Size		Dimensions (mm/in)										Weight	for Bolts	Ø Thread	Ordering Codes	
DN	(in)	ØA	ØA1	F	G	H	H1	I	I1	L	ØK	ØK1	per 100	Metric	Metric	
19	3/4	19	19	70	70	23,8	50,8	50,8	23,8	28	11	18	83,0	M10x35	M10	BFX-602-BAS-602-W1
		.75	.75	2.76	2.76	.94	2.00	2.00	.94	1.10	.43	.71	182.60			
25	1	19	23	70	81	27,8	50,8	57,2	23,8	30	13,5	20	100,9	M12x40	M10	BFX-603-BAS-602-W1
		.75	.91	2.76	3.19	1.09	2.00	2.25	.94	1.18	.53	.79	221.98			
25	1	25	25	75	80	27,8	57,2	27,8	36	36	13,5	20	125,0	M12x45	M12	BFX-603-BAS-603-W1
		.98	.98	2.95	3.15	1.09	2.25	2.25	1.09	1.42	.53	.79	275.00			
32	1-1/4	23	30	83	100	31,8	57,2	66,6	27,8	25	15	22	120,7	M14x40	M12	BFX-604-M14-BAS-603-W1
		.91	1.18	3.27	3.94	1.25	2.25	2.62	1.09	.98	.59	.87	265.54			
32	1-1/4	31	31	90	100	31,8	66,6	66,6	31,8	35	15	22	195,0	M14x50	M14	BFX-604-M14-BAS-604-M14-W1
		1.22	1.22	3.54	3.94	1.25	2.62	2.62	1.25	1.38	.59	.87	429.00			
38	1-1/2	32	40	95	113	36,5	66,6	79,3	31,8	48	17,5	26	236,2	M16x55	M14	BFX-605-BAS-604-M14-W1
		1.26	1.57	3.74	4.45	1.44	2.62	3.12	1.25	1.89	.69	1.02	519.64			
38	1-1/2	38	38	113	113	36,5	79,3	79,3	36,5	50	17,5	26	382,2	M16x55	M16	BFX-605-BAS-605-W1
		1.50	1.50	4.45	4.45	1.44	3.12	3.12	1.44	1.97	.69	1.02	840.84			
51	2	38	49	125	140	44,5	79,3	96,8	36,5	60	22	33	334,9	M20x100	M16	BFX-606-BAS-605-W1
		1.50	1.93	4.92	5.51	1.75	3.12	3.81	1.44	2.36	.87	1.30	736.78			

Materials / Ordering Options / Examples

- * SAE Reducing Flange (without O-ring) made of Steel S355J0 or equivalent, blank (oiled)
- * SAE Reducing Flange (without O-ring) made of Stainless Steel V4A – 1.4404 (on request)

BFX-...-BAS-...-W1
BFX-...-BAS-...-W5



Separate Bolt Sets and Sealings

Bolt Sets

Ordering of bolt sets (consisting of 4 hexagon socket head cap bolts and 4 spring rings) by using the ordering codes as stated below:

Metric bolts (property class 8.8)	KIT-BFX-IS-M12x50-ISO4762-8.8-W66	(Steel, zinc-plated and thick-film-passivated)
Metric bolts (property class 10.9)	KIT-BFX-IS-M12x50-ISO4762-10.9-W1	(Steel, blank and oiled)
UNC bolts (Grade 8)	KIT-BFX-IS-U5/16-18X1-1/4-AB18.3-GR8-W1	(Steel, blank and oiled)

 Thread diameters, dimensions (see corresponding catalogue pages) and property classes / grades have to be chosen to meet your specific requirements.
 Replace material code W66 / W1 with W5 for bolts made of Stainless Steel V4A – 1.4571.

Metric bolts	ISO 4762	Spring rings for Metric bolts	DIN 7980
UNC bolts	ANSI B 18.3	Spring rings for UNC bolts	ANSI B 18.21.1

Sealings
3000 PSI Standard Pressure Series (according to ISO 6162-1)

Nominal Size DN	(in)	Internal Diameter x Cross-Section SAE J515 (STAUFF Standard)	Nominal Size ISO 3601-1
13	1/2	18.64 x 3.53	-210
19	3/4	24.99 x 3.53	-214
25	1	32.92 x 3.53	-219
32	1-1/4	37.69 x 3.53	-222
38	1-1/2	47.22 x 3.53	-225
51	2	56.74 x 3.53	-228
64	2-1/2	69.44 x 3.53	-232
76	3	85.32 x 3.53	-237
89	3-1/2	98.02 x 3.53	-241
102	4	110.72 x 3.53	-245
127	5	136.12 x 3.53	-253

6000 PSI High Pressure Series (according to ISO 6162-2)

Nominal Size DN	(in)	Internal Diameter x Cross-Section SAE J515 (STAUFF Standard)	Nominal Size ISO 3601-1
13	1/2	18.64 x 3.53	-210
19	3/4	24.99 x 3.53	-214
25	1	32.92 x 3.53	-219
32	1-1/4	37.69 x 3.53	-222
38	1-1/2	47.22 x 3.53	-225
51	2	56.74 x 3.53	-228

Ordering Codes
***O-RING-*18.64X*3.53-*B90**

* O-Ring	O-RING
* Internal Diameter (in mm)	18.64
* Cross-Section (in mm)	3.53
* Seal Material	-B90
	NBR (Buna-N®)
	Hardness: 90 Shore
	Temperature Range:
	-30 °C ... +100 °C / -22 °F ... +212 °F
	FKM/FPM (Viton®)
	-V90
	Hardness: 85 ... 90 Shore
	Temperature Range:
	-20 °C ... +200 °C / -4 °F ... +392 °F

Please contact STAUFF for alternative materials.



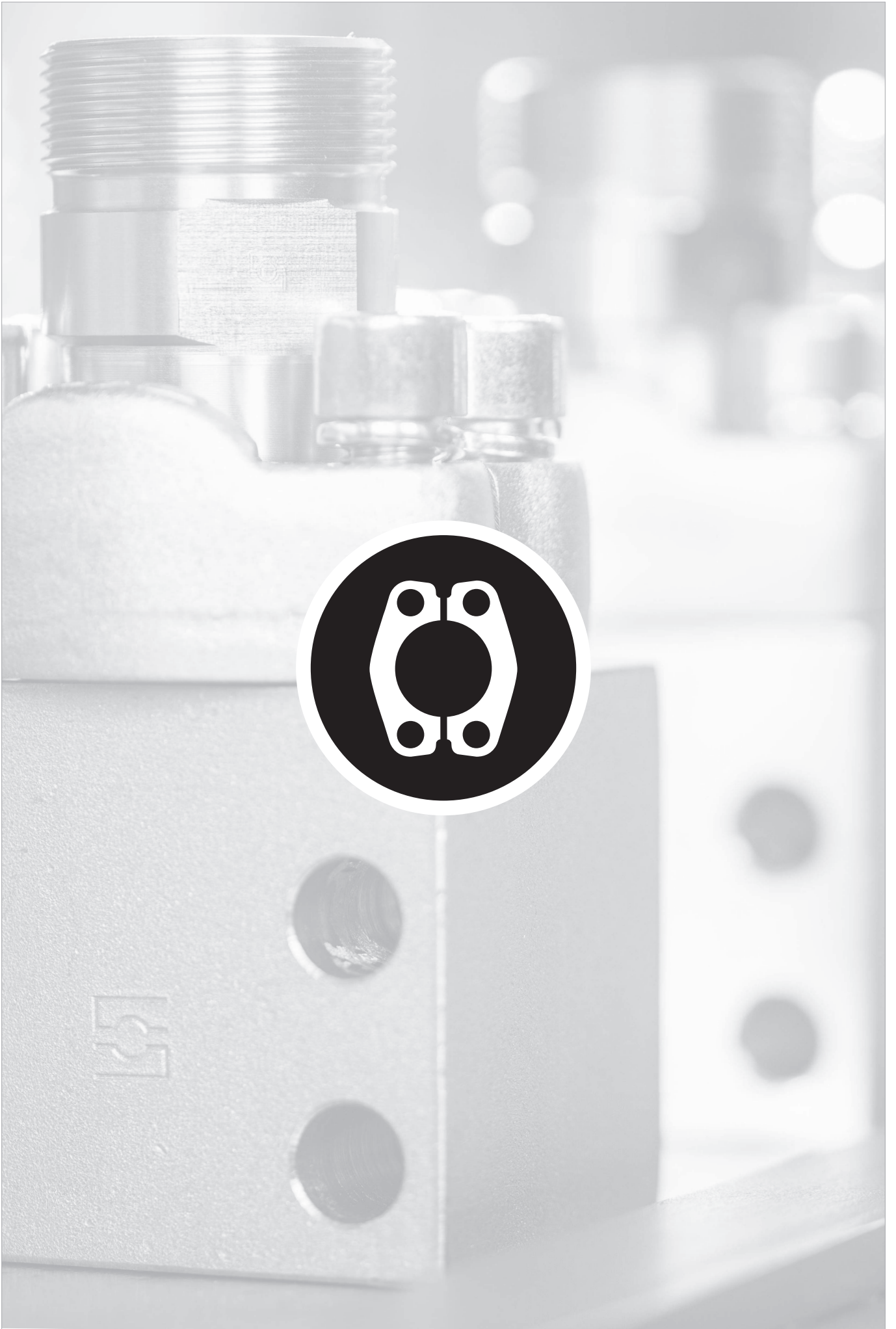



SAE Block T-Connection (Adaptor Style) 92
BF-T



SAE Block T-Connection (Connector Style) 93
BC-T



SAE Block L-Connection (Adaptor Style) 94
BF-L



SAE Block L-Connection (Connector Style) 95
BC-L



SAE Block L-Connection Reduction (Adaptor Style) 96
BF-L

E



SAE Block T-Connection (Adaptor Style)
Type BF-T • 6000 PSI Series

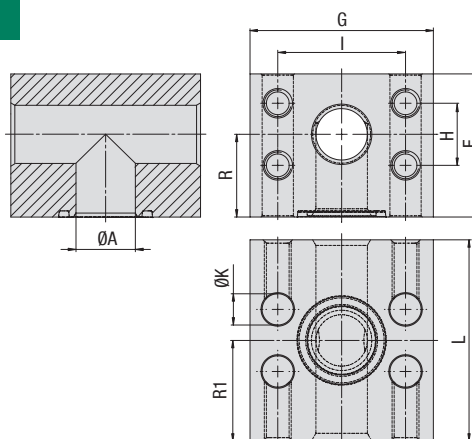

6000 PSI High Pressure Series (based on ISO 6162-2:2002)

Nominal Size		PN ¹ Bolts (bar/PSI)		Dimensions (mm/in)									Weight (^{kg} /lbs) ca. per 100	Ø Thread Metric	Ordering Codes
DN	(in)	8.8	10.9 (MH)	ØA	F	G	H	I	L	R	R1	ØK			
19	3/4	350	420	19	55	72	23,8	50,8	72	32	36	11	176,0	M10	BF-T-602-W66
		5075	6090	.75	2.17	2.83	.94	2.00	2.83	1.26	1.42	.43	387.20		
25	1	350	420	23	64	82	27,8	57,2	90	37	45	13,5	283,0	M12	BF-T-603-W66
		5075	6090	.91	2.52	3.23	1.09	2.25	3.54	1.46	1.77	.53	622.60		
32	1-1/4	350	420	30	72	100	31,8	66,6	100	41	50	15,5	404,7	M14	BF-T-604-M14-W66
		5075	6090	1.18	2.83	3.94	1.25	2.62	3.94	1.61	1.97	.61	890.34		
38	1-1/2	350	420	38	89	114	36,5	79,3	110	50	55	17,5	645,1	M16	BF-T-605-W66
		5075	6090	1.50	3.50	4.49	1.44	3.12	4.33	1.97	2.17	.69	1419.22		
51	2	350	420	50	107	133	44,5	96,8	135	64	67,5	22	1027,5	M20	BF-T-606-W66
		5075	6090	1.97	4.21	5.24	1.75	3.81	5.31	2.52	2.66	.87	2260.50		

E

Materials / Ordering Options / Examples

- * SAE Flange Block made of Steel S355J0 / C45 or equivalent, zinc-plated and thick-film-passivated **BF-T...-W66**
- * SAE Flange Block made of Steel S355J0 / C45 or equivalent, blank (oiled) (on request) **BF-T...-W1**
- * SAE Flange Block made of Steel S355J0 / C45 or equivalent, zinc/nickel-plated (on request) **BF-T...-W3**
- * SAE Flange Block made of Stainless Steel V4A – 1.4404 (on request) **BF-T...-W5**
- * Size of Metric tapped holes deviating from the standard (e.g. M14) **BF-T...-M14-W66**

¹ The maximum working pressure PN (bar/PSI) applies only to the flange itself and depends on the bolts used (Grade 8.8 / 10.9).

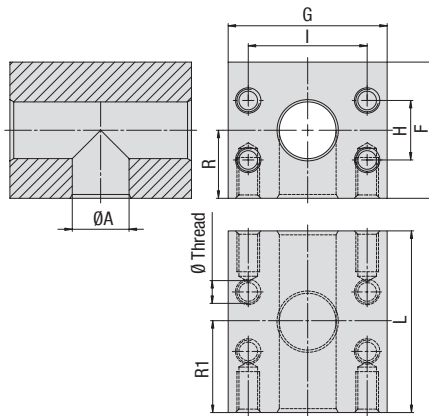

**SAE Block T-Connection (Connector Style)
Type BC-T • 3000 / 6000 PSI Series**

3000 PSI Standard Pressure Series (based on ISO 6162-1:2002)

Nominal Size		PN ¹ Bolts (^{bar} /PSI)		Dimensions (^{mm} / ⁱⁿ)								Weight (^{kg} / ^{lbs}) ca. per 100	Ø Thread Metric	Ordering Codes
DN	(in)	8.8	10.9 (MH)	ØA	F	G	H	I	L	R	R1			
13	1/2	350	350	13	50	55	17,5	38,1	70	25	35	138,3	M8	BC-T-301-W66
		5075	5075	.51	1.97	2.17	.69	1.50	2.76	.98	1.38	304.26		
19	3/4	350	350	19	60	65	22,3	47,6	75	30	37,5	188,9	M10	BC-T-302-W66
		5075	5075	.75	2.36	2.56	.88	1.87	2.95	1.18	1.48	415.58		
25	1	250	315	24	65	72	26,2	52,4	80	33	40	245,4	M10	BC-T-303-W66
		3625	4568	.94	2.56	2.83	1.03	2.06	3.15	1.30	1.57	539.88		
32	1-1/4	200	250	32	80	82	30,2	58,7	90	39	45	368,7	M10	BC-T-304-W66
		2900	3625	1.26	3.15	3.23	1.19	2.31	3.54	1.54	1.77	811.14		
38	1-1/2	200	200	38	92	100	35,7	69,9	110	51	55	641,5	M12	BC-T-305-W66
		2900	2900	1.50	3.62	3.94	1.41	2.75	4.33	2.01	2.17	1411.30		
51	2	160	200	51	87	102	42,9	77,8	120	51	60	564,9	M12	BC-T-306-W66
		2320	2900	2.01	3.43	4.02	1.69	3.06	4.72	2.01	2.36	1242.69		
64	2-1/2	100	160	62	120	115	50,8	88,9	160	60	80	1269,8	M12	BC-T-307-W66
		1450	2320	2.44	4.72	4.53	2.00	3.50	6.30	2.36	3.15	2793.56		
76	3	100	138	73	135	135	61,9	106,4	160	67,5	80	1596,1	M16	BC-T-308-W66
		1450	2001	2.87	5.31	5.31	2.44	4.19	6.30	2.66	3.15	3511.42		
89	3-1/2	35	35	89	145	150	69,9	120,7	160	72,5	80	1734,9	M16	BC-T-309-W66
		508	508	3.50	5.71	5.91	2.75	4.75	6.30	2.85	3.15	3816.78		

6000 PSI High Pressure Series (based on ISO 6162-2:2002)

Nominal Size		PN ¹ Bolts (^{bar} /PSI)		Dimensions (^{mm} / ⁱⁿ)								Weight (^{kg} / ^{lbs}) ca. per 100	Ø Thread Metric	Ordering Codes
DN	(in)	8.8	10.9 (MH)	F	G	H	I	L	R	R1				
13	1/2	350	420	13	50	60	18,2	40,5	90	25	45	194,2	M8	BC-T-601-W66
		5075	6090	.51	1.97	2.36	.72	1.59	3.54	.98	1.77	427.24		
19	3/4	350	420	19	55	72	23,8	50,8	72	32	36	192,9	M10	BC-T-602-W66
		5075	6090	.75	2.17	2.83	.94	2.00	2.83	1.26	1.42	424.38		
25	1	350	420	23	64	82	27,8	57,2	90	37	45	310,4	M12	BC-T-603-W66
		5075	6090	.91	2.52	3.23	1.09	2.25	3.54	1.46	1.77	682.88		
32	1-1/4	350	420	30	72	100	31,8	66,6	100	41	50	300,6	M12	BC-T-604-W66
		5075	6090	1.18	2.83	3.94	1.25	2.62	3.94	1.61	1.97	661.32		
32	1-1/4	350	420	30	72	100	31,8	66,6	100	41	50	300,6	M14	BC-T-604-M14-W66
		5075	6090	1.18	2.83	3.94	1.25	2.62	3.94	1.61	1.97	661.32		
38	1-1/2	350	420	38	89	114	36,5	79,3	110	50	55	688,9	M16	BC-T-605-W66
		5075	6090	1.50	3.50	4.49	1.44	3.12	4.33	1.97	2.17	1515.58		
51	2	350	420	50	107	133	44,5	96,8	135	64	67,5	1113,7	M20	BC-T-606-W66
		5075	6090	1.97	4.21	5.24	1.75	3.81	5.31	2.52	2.66	2450.14		
64	2-1/2	350	420	62	155	180	58,8	123,8	180	77,5	90	1112,3	M24	BC-T-607-W1
		5075	6090	2.44	6.10	7.09	2.31	4.87	7.09	3.05	3.54	2447.06		

¹ The maximum working pressure PN (bar/PSI) applies only to the flange itself and depends on the bolts used (Grade 8.8 / 10.9).

Materials / Ordering Options / Examples

- * SAE Flange Block made of Steel S355J0 / C45 or equivalent, zinc-plated and thick-film-passivated BC-T...-W66
- * SAE Flange Block made of Steel S355J0 / C45 or equivalent, blank (oiled) (on request) BC-T...-W1
- * SAE Flange Block made of Steel S355J0 / C45 or equivalent, zinc/nickel-plated (on request) BC-T...-W3
- * SAE Flange Block made of Stainless Steel V4A – 1.4404 (on request) BC-T...-W5
- * Size of Metric tapped holes deviating from the standard (e.g. M14) BC-T...-M14-W66



**SAE Block L-Connection (Adaptor Style)
Type BF-L - 3000 / 6000 PSI Series**

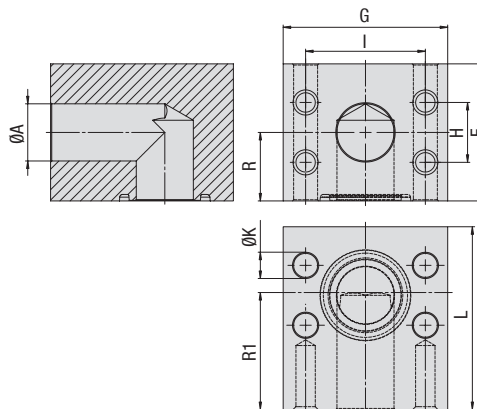

3000 PSI Standard Pressure Series (based on ISO 6162-1:2002)

Nominal Size	PN ¹ Bolts (^{bar} /PSI)	Dimensions (^{mm} / ⁱⁿ)											Weight (^{kg} / ^{lbs}) ca. per 100	Ø Thread Metric	Ordering Codes
		DN	(in)	8.8	10.9 (MH)	ØA	F	G	H	I	L	R			
13	1/2	350	350	13	50	55	17,5	38,1	55	25	35	9	103,3	M8	BF-L-301-W66
		5075	5075	.51	1.97	2.17	.69	1.50	2.17	.98	1.38	.35	227.26		
20	3/4	350	350	19	60	65	22,3	47,6	60	30	40	11	146,7	M10	BF-L-302-W66
		5075	5075	.75	2.36	2.56	.88	1.87	2.36	1.18	1.57	.43	322.74		
25	1	250	315	24	65	72	26,2	52,4	65	33	40	11	189,7	M10	BF-L-303-W66
		3625	4568	.94	2.56	2.83	1.03	2.06	2.56	1.30	1.57	.43	417.34		
32	1-1/4	200	200	32	80	82	30,2	58,7	82	39	38	11	349,3	M10	BF-L-304-W66
		2900	2900	1.26	3.15	3.23	1.19	2.31	3.23	1.54	1.50	.43	768.46		
38	1-1/2	160	200	38	92	100	35,7	69,9	92	51	59	13,5	510,9	M12	BF-L-305-W66
		2320	2900	1.50	3.62	3.94	1.41	2.75	3.62	2.01	2.32	.53	1123.98		
51	2	100	160	51	87	102	42,9	77,8	85	51	48	13,5	376,0	M12	BF-L-306-W66
		1450	2320	2.01	3.43	4.02	1.69	3.06	3.35	2.01	1.89	.53	827.20		
64	2-1/2	100	160	62	120	110	50,8	88,9	110	60	65	13,5	842,5	M12	BF-L-307-W66
		1450	2320	2.44	4.72	4.33	2.00	3.50	4.33	2.36	2.56	.53	1853.50		
76	3	100	138	73	135	135	61,9	106,4	150	67,5	90	17,5	1481,7	M16	BF-L-308-W66
		1450	2001	2.87	5.31	5.31	2.44	4.19	5.91	2.66	3.54	.69	3259.74		
89	3-1/2	35	35	89	145	150	69,9	120,7	145	72,5	75	17,5	1653,6	M16	BF-L-309-W66
		508	508	3.50	5.71	5.91	2.75	4.75	5.71	2.85	2.95	.69	3637.92		

6000 PSI High Pressure Series (based on ISO 6162-2:2002)

Nominal Size	PN ¹ Bolts (^{bar} /PSI)	Dimensions (^{mm} / ⁱⁿ)											Weight (^{kg} / ^{lbs}) ca. per 100	Ø Thread Metric	Ordering Codes
		DN	(in)	8.8	10.9 (MH)	F	G	H	I	L	R	R1			
13	1/2	350	420	13	50	60	18,2	40,5	60	25	40	9	122,9	M8	BF-L-601-W66
		5075	6090	.51	1.97	2.36	.72	1.59	2.36	.98	1.57	.35	270.38		
19	3/4	350	420	19	55	72	23,8	50,8	60	32	36	11	149,5	M10	BF-L-602-W66
		5075	6090	.75	2.17	2.83	.94	2.00	2.36	1.26	1.42	.43	328.90		
25	1	350	420	23	64	82	27,8	57,2	68	37	40	13,5	210,3	M12	BF-L-603-W66
		5075	6090	.91	2.52	3.23	1.09	2.25	2.68	1.46	1.57	.53	462.66		
32	1-1/4	350	420	30	72	100	31,8	66,6	76	41	46	13,5	348,5	M12	BF-L-604-W66
		5075	6090	1.18	2.83	3.94	1.25	2.62	2.99	1.61	1.81	.53	766.70		
32	1-1/4	350	420	30	72	100	31,8	66,6	76	41	46	15,5	322,9	M14	BF-L-604-M14-W66
		5075	6090	1.18	2.83	3.94	1.25	2.62	2.99	1.61	1.81	.61	710.38		
38	1-1/2	350	420	38	89	114	36,5	79,3	86	50	52	17,5	494,1	M16	BF-L-605-W66
		5075	6090	1.50	3.50	4.49	1.44	3.12	3.39	1.97	2.05	.69	1086.91		
51	2	350	420	50	107	133	44,5	96,8	107	64	70	22	816,8	M20	BF-L-606-W66
		5075	6090	1.97	4.21	5.24	1.75	3.81	4.21	2.52	2.76	.87	1796.96		
64	2-1/2	350	420	62	155	180	58,8	123,8	160	77,5	90	26	829,6	M24	BF-L-607-W1
		5075	6090	2.44	6.10	7.09	2.31	4.87	6.30	3.05	3.54	1.02	1825.12		

Materials / Ordering Options / Examples

- * SAE Flange Block made of Steel S355J0 / C45 or equivalent, zinc-plated and thick-film-passivated **BF-L-...-W66**
- * SAE Flange Block made of Steel S355J0 / C45 or equivalent, blank (oiled) (on request) **BF-L-...-W1**
- * SAE Flange Block made of Steel S355J0 / C45 or equivalent, zinc/nickel-plated (on request) **BF-L-...-W3**
- * SAE Flange Block made of Stainless Steel V4A – 1.4404 (on request) **BF-L-...-W5**
- * Size of Metric tapped holes deviating from the standard (e.g. M14) **BF-L-...-M14-W66**

¹ The maximum working pressure PN (bar/PSI) applies only to the flange itself and depends on the bolts used (Grade 8.8 / 10.9).

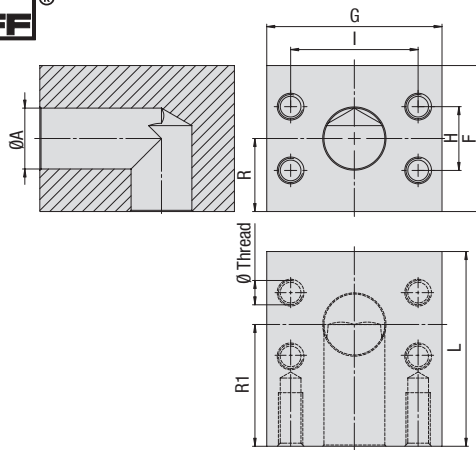

**SAE Block L-Connection (Connector Style)
Type BC-L • 3000 / 6000 PSI Series**

3000 PSI Standard Pressure Series (based on ISO 6162-1:2002)

Nominal Size		PN ¹ Bolts (^{bar} /PSI)		Dimensions (^{mm} / ⁱⁿ)								Weight (^{kg} / ^{lbs}) ca. per 100	Ø Thread Metric	Ordering Codes
DN	(in)	8.8	10.9 (MH)	ØA	F	G	H	I	L	R	R1			
13	1/2	350	350	13	50	55	17,5	38,1	55	25	35	109,1	M8	BC-L-301-W66
		5075	5075	.51	1.97	2.17	.69	1.50	2.17	.98	1.38	240.02		
20	3/4	350	350	19	60	65	22,3	47,6	60	30	40	157,9	M10	BC-L-302-W66
		5075	5075	.75	2.36	2.56	.88	1.87	2.36	1.18	1.57	347.38		
25	1	250	315	24	65	72	26,2	52,4	65	33	40	204,3	M10	BC-L-303-W66
		3625	4568	.94	2.56	2.83	1.03	2.06	2.56	1.30	1.57	449.46		
32	1-1/4	200	200	32	80	82	30,2	58,7	82	39	38	366,7	M10	BC-L-304-W66
		2900	2900	1.26	3.15	3.23	1.19	2.31	3.23	1.54	1.50	806.74		
38	1-1/2	160	200	38	92	100	35,7	69,9	92	51	59	547,1	M12	BC-L-305-W66
		2320	2900	1.50	3.62	3.94	1.41	2.75	3.62	2.01	2.32	1203.62		
51	2	100	160	51	87	102	42,9	77,8	85	51	48	403,4	M12	BC-L-306-W66
		1450	2320	2.01	3.43	4.02	1.69	3.06	3.35	2.01	1.89	887.48		
64	2-1/2	100	160	62	120	110	50,8	88,9	110	60	65	966,5	M12	BC-L-307-W66
		1450	2320	2.44	4.72	4.33	2.00	3.50	4.33	2.36	2.56	2126.30		
76	3	100	138	73	135	135	61,9	106,4	150	67,5	90	1629,3	M16	BC-L-308-W66
		1450	2001	2.87	5.31	5.31	2.44	4.19	5.91	2.66	3.54	3584.46		
89	3-1/2	35	35	89	145	150	69,9	120,7	145	72,5	75	1744,7	M16	BC-L-309-W66
		508	508	3.50	5.71	5.91	2.75	4.75	5.71	2.85	2.95	3838.34		

6000 PSI High Pressure Series (based on ISO 6162-2:2002)

Nominal Size		PN ¹ Bolts (^{bar} /PSI)		Dimensions (^{mm} / ⁱⁿ)								Weight (^{kg} / ^{lbs}) ca. per 100	Ø Thread Metric	Ordering Codes
DN	(in)	8.8	10.9 (MH)	F	G	H	I	L	R	R1				
13	1/2	350	420	13	50	60	18,2	40,5	60	25	40	130,0	M8	BC-L-601-W66
		5075	6090	.51	1.97	2.36	.72	1.59	2.36	.98	1.57	286.00		
19	3/4	350	420	19	55	72	23,8	50,8	60	32	36	161,9	M10	BC-L-602-W66
		5075	6090	.75	2.17	2.83	.94	2.00	2.36	1.26	1.42	356.18		
25	1	350	420	23	64	82	27,8	57,2	68	37	40	238,9	M12	BC-L-603-W66
		5075	6090	.91	2.52	3.23	1.09	2.25	2.68	1.46	1.57	525.58		
32	1-1/4	350	420	30	72	100	31,8	66,6	76	41	46	233,4	M12	BC-L-604-W66
		5075	6090	1.18	2.83	3.94	1.25	2.62	2.99	1.61	1.81	513.48		
32	1-1/4	350	420	30	72	100	31,8	66,6	76	41	46	233,4	M14	BC-L-604-M14-W66
		5075	6090	1.18	2.83	3.94	1.25	2.62	2.99	1.61	1.81	513.48		
38	1-1/2	350	420	38	89	114	36,5	79,3	86	50	52	558,1	M16	BC-L-605-W66
		5075	6090	1.50	3.50	4.49	1.44	3.12	3.39	1.97	2.05	1227.82		
51	2	350	420	50	107	133	44,5	96,8	107	64	70	894,4	M20	BC-L-606-W66
		5075	6090	1.97	4.21	5.24	1.75	3.81	4.21	2.52	2.76	1967.68		
64	2-1/2	350	420	62	155	180	58,8	123,8	160	77,5	90	911,1	M24	BC-L-607-W1
		5075	6090	2.44	6.10	7.09	2.31	4.87	6.30	3.05	3.54	2004.42		

¹ The maximum working pressure PN (bar/PSI) applies only to the flange itself and depends on the bolts used (Grade 8.8 / 10.9).

Materials / Ordering Options / Examples

- * SAE Flange Block made of Steel S355J0 / C45 or equivalent, zinc-plated and thick-film-passivated BC-L-...-W66
- * SAE Flange Block made of Steel S355J0 / C45 or equivalent, blank (oiled) (on request) BC-L-...-W1
- * SAE Flange Block made of Steel S355J0 / C45 or equivalent, zinc/nickel-plated (on request) BC-L-...-W3
- * SAE Flange Block made of Stainless Steel V4A – 1.4404 (on request) BC-L-...-W5
- * Size of Metric tapped holes deviating from the standard (e.g. M14) BC-L-...-M14-W66



**SAE Block L-Connection Reduction (Adaptor Style)
Type BF-L • 6000 PSI Series**

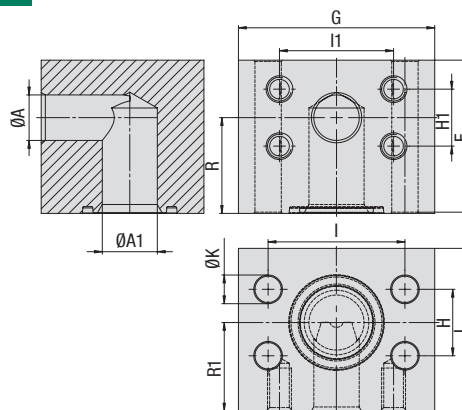

6000 PSI High Pressure Series (based on ISO 6162-2:2002)

Nominal Size		PN ¹ Bolts (bar/PSI)		Dimensions (mm/in)												Weight (^{kg} /lbs) ca. per 100	Ø Thread Metric	Ordering Codes
DN	(in)	8.8	10.9 (MH)	ØA	ØA1	F	G	H	H1	I1	I	L	R	R1	ØK			
25 - 19	1 - 3/4	350	420	19	23	64	82	27,8	23,8	50,8	57,2	68	37	40	14	223,0	M10	BF-L-603-602-W66
		5075	6090	.75	.91	2.52	3.23	1.09	.94	2.00	2.25	2.68	1.46	1.57	.55	490.60		
32 - 19	1-1/4 - 3/4	350	420	19	30	72	100	31,8	23,8	50,8	66,6	76	41	46	16	345,4	M10	BF-L-604-M14-602-W66
		5075	6090	.75	1.18	2.83	3.94	1.25	.94	2.00	2.62	2.99	1.61	1.81	.63	759.88		
32 - 25	1-1/4 - 1	350	420	23	30	72	100	31,8	27,8	57,2	66,6	76	41	46	16	333,2	M12	BF-L-604-M14-603-W66
		5075	6090	.91	1.18	2.83	3.94	1.25	1.09	2.25	2.62	2.99	1.61	1.81	.63	733.04		
38 - 32	1-1/2 - 1-1/4	350	420	30	38	89	114	36,5	31,8	66,6	79,3	86	50	52	18	541,3	M14	BF-L-605-604-M14-W66
		5075	6090	1.18	1.50	3.50	4.49	1.44	1.25	2.62	3.12	3.39	1.97	2.05	.71	1190.86		
51 - 38	2 - 1-1/2	350	420	38	50	107	133	44,5	36,5	79,3	96,8	107	64	70	22	893,5	M16	BF-L-606-605-W66
		5075	6090	1.50	1.97	4.21	5.24	1.75	1.44	3.12	3.81	4.21	2.52	2.76	.87	1965.70		

E

Materials / Ordering Options / Examples

- * SAE Flange Block made of Steel S355J0 / C45 or equivalent, zinc-plated and thick-film-passivated **BF-L-...-W66**
- * SAE Flange Block made of Steel S355J0 / C45 or equivalent, blank (oiled) (on request) **BF-L-...-W1**
- * SAE Flange Block made of Steel S355J0 / C45 or equivalent, zinc/nickel-plated (on request) **BF-L-...-W3**
- * SAE Flange Block made of Stainless Steel V4A – 1.4404 (on request) **BF-L-...-W5**
- * Size of Metric tapped holes deviating from the standard (e.g. M14) **BF-L-...-M14-...-W66**
- * Size of through holes deviating from the standard (e.g. for bolts M14) **BF-L-...-M14-W66**

¹ The maximum working pressure PN (bar/PSI) applies only to the flange itself and depends on the bolts used (Grade 8.8 / 10.9).



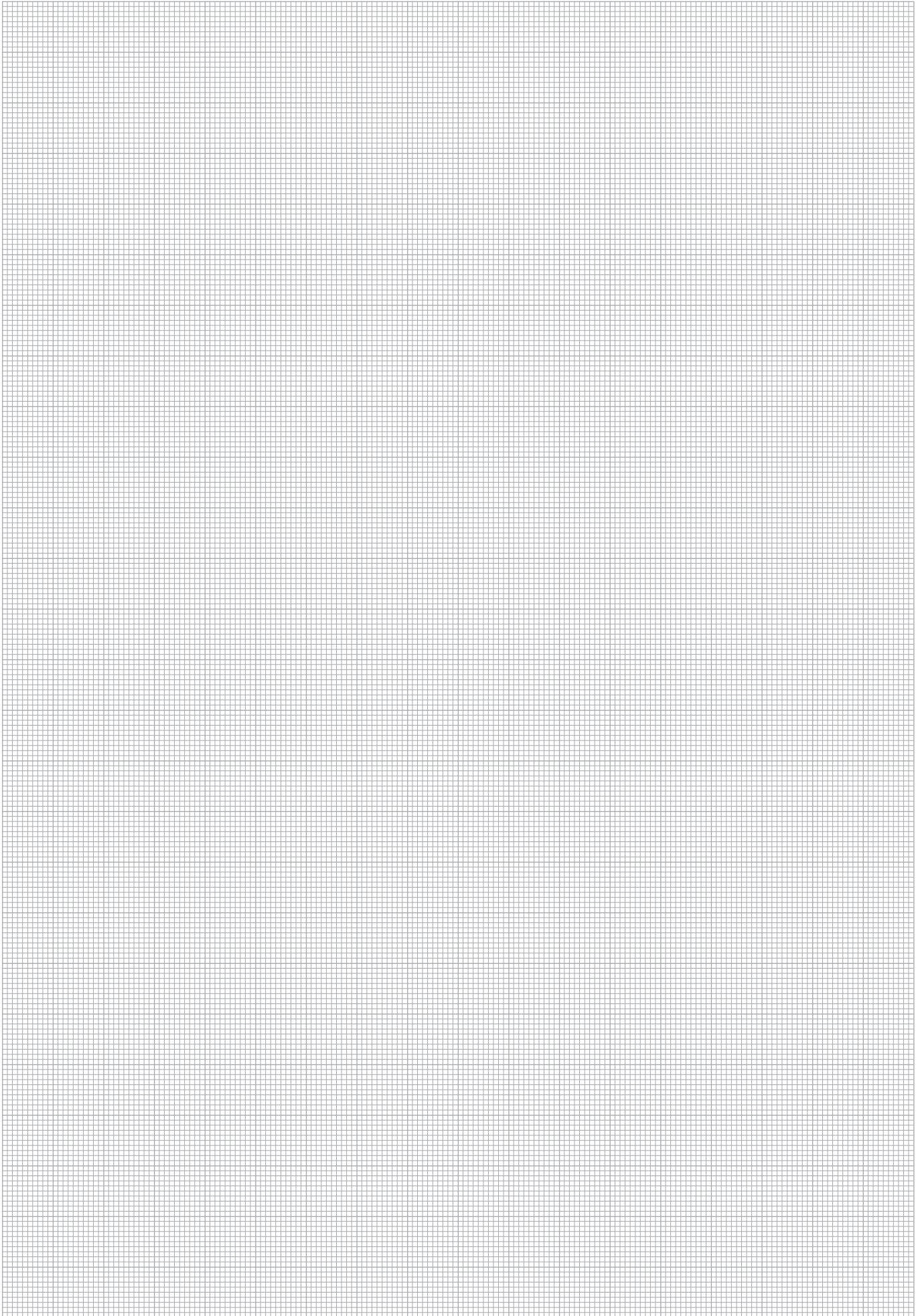





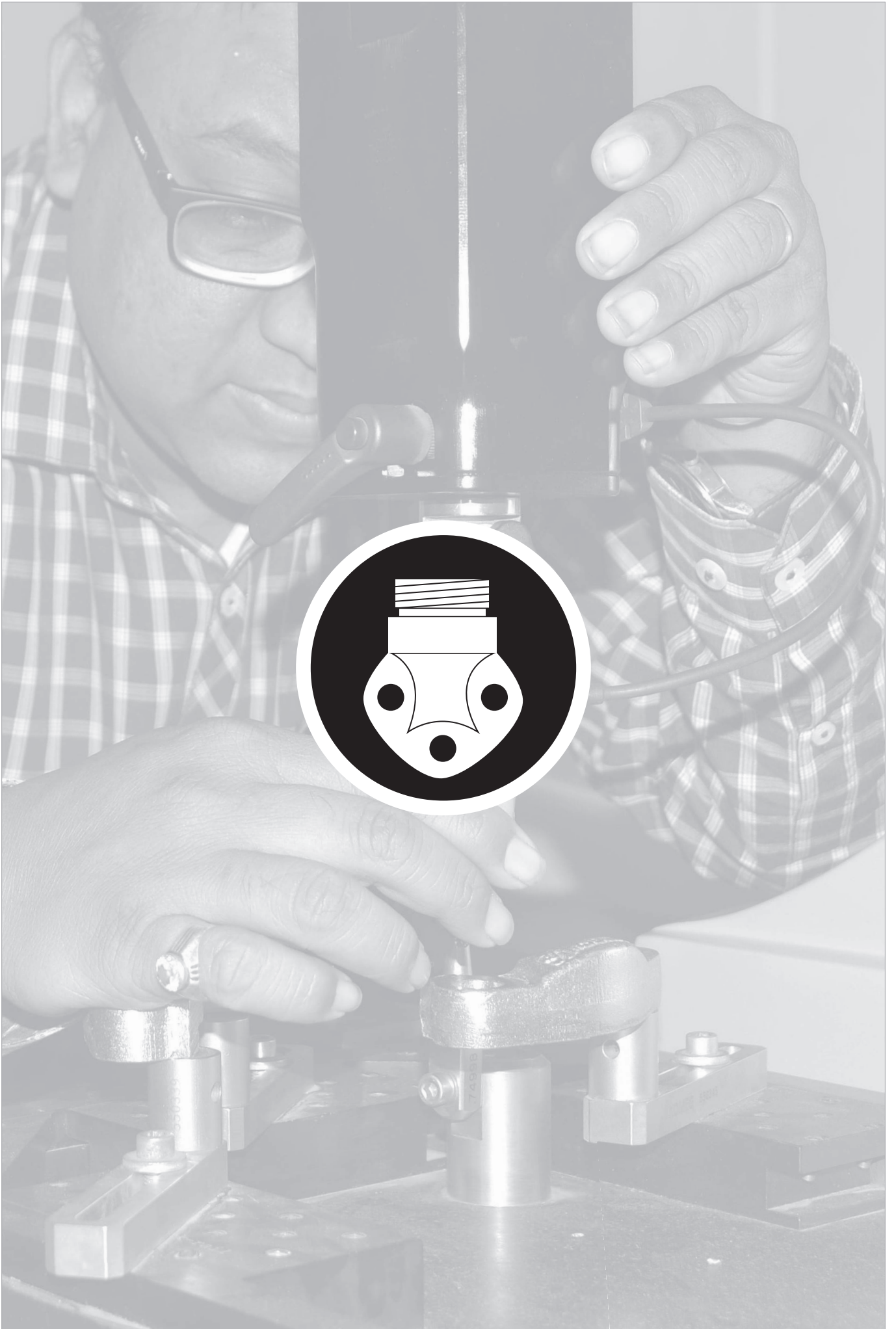





E





	4-Hole Flange with Male Metric Thread and 24° Conical Bore (Shape W acc. to DIN 3861) GP-LK-L/S	100
	4-Hole 90° Flange with Male Metric Thread and 24° Conical Bore (Shape W acc. to DIN 3861) WP-3-LK-L/S	101
	3-Hole 90° Flange with Male Metric Thread and 24° Conical Bore (Shape W acc. to DIN 3861) WP-3-LK-L/S	102
	3-Hole 90° Flange with Female BSPP Thread WP-3-LK-G	103
	4-Hole 90° Flange with Female BSPP Thread WP-LK-G	104
	3-Hole 90° Flange with Female BSPP Thread (Aluminium) WP-3-LK-G-W50	105
	4-Hole 90° Flange with Female BSPP Thread (Aluminium) WP-LK-G-W50	106
	4-Hole Flange with Female BSPP Thread (Flat Style) GP-FL-LK-G	107
	4-Hole Butt-Weld Flange GP-LK-ST	108
	4-Hole Flange with Male BSPP Thread and 60° Conical Bore (acc. to BS 5200) GP-LK-B	109
	4-Hole Flange with Female BSPP Thread GP-LK-G	110



4-Hole Flange with Male Metric Thread and 24° Conical Bore (Shape W acc. to DIN 3861) Type GP-LK-L/S

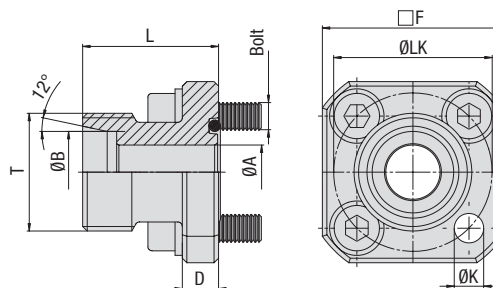

PN ¹ (bar/PSI)	Dimensions (mm/in)			Series	D	F	L	T (Metric)	ØK	Weight (kg/lbs) ca. per 100	Bolts Metric	O-ring	Ordering Codes
	ØLK	ØA	ØB										
315	35	7	10	L	8	40	30	16x1,5	6,5	13,1	4 x M6x22	20x2,5	GP-LK35-10L-W3-K
4568	1.38	.28	.39	L	.31	1.57	1.18	18x1,5	.26	28.82	4 x M6x22	20x2,5	GP-LK35-12L-W3-K
315	35	9	12	L	8	40	30	16x1,5	6,5	13,5	4 x M6x22	20x2,5	GP-LK35-12L-W3-K
4568	1.38	.35	.47	L	.31	1.57	1.18	18x1,5	.26	29.70	4 x M6x22	20x2,5	GP-LK35-12L-W3-K
250	35	11	15	L	8	40	30	22x1,5	6,5	14,8	4 x M6x22	20x2,5	GP-LK35-15L-W3-K
3625	1.38	.43	.59	L	.31	1.57	1.18	22x1,5	.26	32.56	4 x M6x22	20x2,5	GP-LK35-15L-W3-K
250	35	12	18	L	8	40	30	26x1,5	6,5	15,3	4 x M6x22	20x2,5	GP-LK35-18L-W3-K
3625	1.38	.47	.71	L	.31	1.57	1.18	26x1,5	.26	33.66	4 x M6x22	20x2,5	GP-LK35-18L-W3-K
315	35	12	16	S	8	40	30	24x1,5	6,5	14,5	4 x M6x22	20x2,5	GP-LK35-16S-W3-K
4568	1.38	.47	.63	S	.31	1.57	1.18	24x1,5	.26	31.90	4 x M6x22	20x2,5	GP-LK35-16S-W3-K
100	40	11	15	L	8	40	35	22x1,5	6,5	15,7	4 x M6x22	26x2,5	GP-LK40-15L-W3-K
1450	1.57	.43	.59	L	.31	1.57	1.38	22x1,5	.26	34.54	4 x M6x22	26x2,5	GP-LK40-15L-W3-K
100	40	14	18	L	8	40	35	26x1,5	6,5	16,8	4 x M6x22	26x2,5	GP-LK40-18L-W3-K
1450	1.57	.55	.71	L	.31	1.57	1.38	26x1,5	.26	36.96	4 x M6x22	26x2,5	GP-LK40-18L-W3-K
100	40	18	22	L	8	40	35	30x2	6,5	16,3	4 x M6x22	26x2,5	GP-LK40-22L-W3-K
1450	1.57	.71	.87	L	.31	1.57	1.38	30x2	.26	35.86	4 x M6x22	26x2,5	GP-LK40-22L-W3-K
100	40	18	28	L	8	40	35	36x2	6,5	18,0	4 x M6x22	26x2,5	GP-LK40-28L-W3-K
1450	1.57	.71	1.10	L	.31	1.57	1.38	36x2	.26	39.60	4 x M6x22	26x2,5	GP-LK40-28L-W3-K
100	55	25	28	L	12	55	40	36x2	8,5	34,3	4 x M8x25	32x2,5	GP-LK55-28L-W3-K
1450	2.17	.98	1.10	L	.47	2.17	1.57	36x2	.33	75.46	4 x M8x25	32x2,5	GP-LK55-28L-W3-K
100	55	25	35	L	12	55	50	45x2	8,5	50,2	4 x M8x25	32x2,5	GP-LK55-35L-W3-K
1450	2.17	.98	1.38	L	.47	2.17	1.97	45x2	.33	110.44	4 x M8x25	32x2,5	GP-LK55-35L-W3-K
250	55	16	20	S	12	55	35	30x2	8,5	42,9	4 x M8x25	32x2,5	GP-LK55-20S-W3-K
3625	2.17	.63	.79	S	.47	2.17	1.38	30x2	.33	94.38	4 x M8x25	32x2,5	GP-LK55-20S-W3-K

F

Materials / Ordering Options / Examples

* Kit with 4-Hole Flange made of Steel S355J0 or equivalent, zinc/nickel-plated including Metric bolts 8.8, spring rings, O-ring made of NBR (Buna-N®)

GP-LK...-...-W3-K

Please always indicate ØLK, ØB and Series.

¹ The maximum working pressure PN (bar/PSI) applies only to the flange itself. The actual maximum working pressure depends on the thickness and the quality of the tube used.



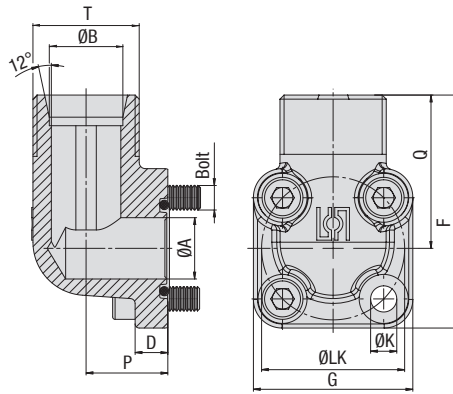

4-Hole 90° Flange with Male Metric Thread and 24° Conical Bore (Shape W acc. to DIN 3861) Type WP-LK-L/S



PN ¹ (bar/PSI)	Dimensions (mm/in)			Series	D	F	G	P	Q	T (Metric)	ØK	Weight (kg/lbs) ca. per 100	Bolts Metric	O-ring	Ordering Codes
8.8	ØLK	ØA	ØB												
315	35	14	10	L	8	57	39	16,5	37,5	16x1,5	6,4	18,4	2 x M6x22	20x2,5	WP-LK35-10L-W3-K
4568	1.38	.55	.39	L	.31	2.24	1.54	.65	1.48		.25	40.48	2 x M6x35		
315	35	14	12	L	8	57	39	16,5	37,5	18x1,5	6,4	19,2	2 x M6x22	20x2,5	WP-LK35-12L-W3-K
4568	1.38	.55	.47	L	.31	2.24	1.54	.65	1.48		.25	42.24	2 x M6x35		
250	35	14	15	L	8	56,5	39	16,5	37,5	22x1,5	6,4	20,2	2 x M6x22	20x2,5	WP-LK35-15L-W3-K
3625	1.38	.55	.59	L	.31	2.22	1.54	.65	1.48		.25	44.44	2 x M6x35		
250	35	15	18	L	8	57	39	20	37,5	26x1,5	6,4	22,0	2 x M6x22	20x2,5	WP-LK35-18L-W3-K
3625	1.38	.59	.71	L	.31	2.24	1.54	.79	1.48		.25	48.40	2 x M6x40		
315	35	15	16	S	8	57,5	39	20	38	24x1,5	6,4	25,3	2 x M6x22	20x2,5	WP-LK35-16S-W3-K
4568	1.38	.59	.63	S	.31	2.26	1.54	.79	1.50		.25	55.66	2 x M6x40		
315	35	15	20	S	8	64,5	39	25	45	30x2	6,4	30,3	2 x M6x22	20x2,5	WP-LK35-20S-W3-K
4568	1.38	.59	.79	S	.31	2.54	1.54	.98	1.77		.25	66.66	2 x M6x45		
100	40	20	15	L	9	58	42	22,5	37	22x1,5	6,4	26,0	4 x M6x22	26x2,5	WP-LK40-15L-W3-K
1450	1.57	.79	.59	L	.35	2.28	1.65	.89	1.46		.25	57.14			
100	40	20	18	L	9	59	42	22,5	38	26x1,5	6,4	26,8	4 x M6x22	26x2,5	WP-LK40-18L-W3-K
1450	1.57	.79	.71	L	.35	2.32	1.65	.89	1.50		.25	58.96			
100	40	20	22	L	9	59	42	22,5	38	30x2	6,4	26,7	4 x M6x22	26x2,5	WP-LK40-22L-W3-K
1450	1.57	.79	.87	L	.35	2.32	1.65	.89	1.50		.25	58.84			
100	40	20	28	L	9	61	42	28	40	36x2	6,4	36,9	2 x M6x22	26x2,5	WP-LK40-28L-W3-K
1450	1.57	.79	1.10	L	.35	2.40	1.65	1.10	1.57		.25	81.27	2 x M6x50		
100	40	20	35	L	9	62	42	34	41	45x2	6,4	40,6	2 x M6x22	26x2,5	WP-LK40-35L-W3-K
1450	1.57	.79	1.38	L	.35	2.44	1.65	1.34	1.61		.25	89.32	2 x M6x60		
250	40	20	20	S	9	61	42	22,5	40	30x2	6,4	25,9	2 x M6x22	26x2,5	WP-LK40-20S-W3-K
3625	1.57	.79	.79	S	.35	2.40	1.65	.89	1.57		.25	56.98	2 x M6x45		
100	55	26,5	35	L	12	78	58	32	49	45x2	8,4	76,6	2 x M8x25	32x2,5	WP-LK55-35L-W3-K
1450	2.17	1.04	1.38	L	.47	3.07	2.28	1.26	1.93		.33	168.52	2 x M8x60		
100	55	26,5	42	L	12	78	58	40	49	52x2	8,4	103,6	2 x M8x25	32x2,5	WP-LK55-42L-W3-K
1450	2.17	1.04	1.65	L	.47	3.07	2.28	1.57	1.93		.33	227.88	2 x M8x70		
250	55	18	20	S	13	69	58	24	45	30x2	8,4	61,7	2 x M8x25	32x2,5	WP-LK55-20S-W3-K
3625	2.17	.71	.79	S	.51	2.72	2.28	.94	1.77		.33	135.70	2 x M8x50		
250	55	26,5	25	S	13	78	58	30	49	36x2	8,4	62,0	2 x M8x25	32x2,5	WP-LK55-25S-W3-K
3625	2.17	1.04	.98	S	.51	3.07	2.28	1.18	1.93		.33	136.40	2 x M8x55		
250	55	26,5	30	S	12	78	58	32	49	42x2	8,4	63,2	2 x M8x25	32x2,5	WP-LK55-30S-W3-K
3625	2.17	1.04	1.18	S	.47	3.07	2.28	1.26	1.93		.33	139.04	2 x M8x50		

¹ The maximum working pressure PN (bar/PSI) applies only to the flange itself. The actual maximum working pressure depends on the thickness and the quality of the tube used.

Materials / Ordering Options / Examples

* Kit with 4-Hole Flange made of Steel S355J0 or equivalent, zinc/nickel-plated including Metric bolts 8.8, spring rings, O-ring made of NBR (Buna-N®)

WP-LK...-...-W3-K

Please always indicate ØLK, ØB and Series.



3-Hole 90° Flange with Male Metric Thread and 24° Conical Bore (Shape W acc. to DIN 3861) Type WP-3-LK-L/S

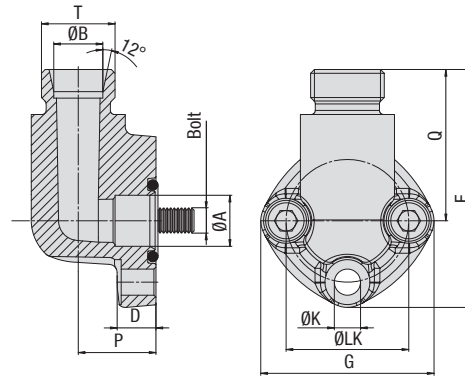

PN ¹ (bar/PSI)	Dimensions (mm/in)			L	D	F	G	P	Q	T (Metric)	ØK	Weight (kg/lbs) ca. per 100	Bolts Metric	O-ring	Ordering Codes
	ØLK	ØA	ØB												
250	30	12,5	12	L	9,5	58	42,5	19	37	18x1,5	6,4	17,7	3 x M6x25	16x2,5	WP-3-LK30-12L-W3-K
3625	1.18	.49	.47		.37	2.28	1.67	.75	1.46			.25			
250	30	12,5	15	L	9,5	58	42,5	19	37	22x1,5	6,4	19,5	3 x M6x25	16x2,5	WP-3-LK30-15L-W3-K
3625	1.18	.49	.59		.37	2.28	1.67	.75	1.46			.25			
160	40	19	22	L	13,5	70	54	25	43	30x2	8,4	40,4	3 x M8x30	24x2,5	WP-3-LK40-22L-W3-K
2320	1.57	.75	.87		.53	2.76	2.13	.98	1.69			.33			
160	40	19	28	L	13,5	70	54	25	43	36x2	8,4	35,7	3 x M8x30	24x2,5	WP-3-LK40-28L-W3-K
2320	1.57	.75	1.10		.53	2.76	2.13	.98	1.69			.33			

F

Materials / Ordering Options / Examples

* Kit with 3-Hole Flange made of Steel S355J0 or equivalent, zinc/nickel-plated including Metric bolts 8.8, spring rings, O-ring made of NBR (Buna-N®)

WP-3-LK...-...-W3-K

Please always indicate ØLK, ØB and Series.

¹ The maximum working pressure PN (bar/PSI) applies only to the flange itself. The actual maximum working pressure depends on the thickness and the quality of the tube used.



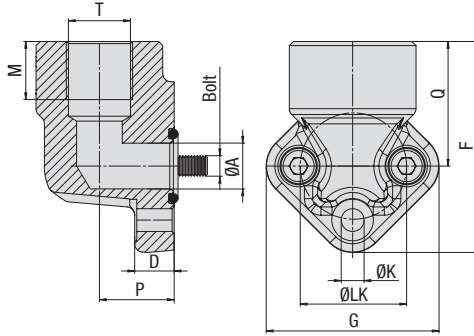

3-Hole 90° Flange with Female BSPP Thread Type WP-3-LK-G



PN ¹ (bar/PSI)	Dimensions (mm/in)										Weight (kg/lbs) ca. per 100	Bolts Metric	O-ring	Ordering Codes
	ØLK	ØA	D	F	G	M	P	Q	T (BSPP)	ØK				
300	26	11,5	9,5	51	42	14	18	30	3/8 (06)	5,5	9,1	3 x M5x20	14x1,78	WP-3-LK26-G06-W3-K
4350	1.02	.45	.37	2.01	1.65	.55	.71	1.18		.22	20.02			
300	26	11,5	9,5	51	42	14	18	30	1/2 (08)	5,5	8,6	3 x M5x20	14x1,78	WP-3-LK26-G08-W3-K
4350	1.02	.45	.37	2.01	1.65	.55	.71	1.18		.22	18.92			
300	30	11,5	9,5	51	42	14	18	30	3/8 (06)	6,5	12,0	3 x M6x20	16x2,5	WP-3-LK30-G06-W3-K
4350	1.18	.45	.37	2.01	1.65	.55	.71	1.18		.26	26.40			
300	30	11,5	9,5	51	42	14	18	30	1/2 (08)	6,5	11,2	3 x M6x20	16x2,5	WP-3-LK30-G08-W3-K
4350	1.18	.45	.37	2.01	1.65	.55	.71	1.18		.26	24.64			
300	40	18	11,5	68	61	18	21	38	1/2 (08)	8,5	24,0	3 x M8x25	24x2,5	WP-3-LK40-G08-W3-K
4350	1.57	.71	.45	2.68	2.40	.71	.83	1.50		.33	52.80			
300	40	18	11,5	68	61	22	21	38	3/4 (12)	8,5	22,8	3 x M8x25	24x2,5	WP-3-LK40-G12-W3-K
4350	1.57	.71	.45	2.68	2.40	.87	.83	1.50		.33	50.16			
300	51	25	13,5	84	75	22	27	47	3/4 (12)	10,5	49,8	3 x M10x30	32x2,5	WP-3-LK51-G12-W3-K
4350	2.01	.98	.53	3.31	2.95	.87	1.06	1.85		.41	109.56			
300	51	25	13,5	84	75	27	27	47	1 (16)	10,5	46,4	3 x M10x30	32x2,5	WP-3-LK51-G16-W3-K
4350	2.01	.98	.53	3.31	2.95	1.06	1.06	1.85		.41	102.08			
300	56	34	13,5	84	75	22	27	47	3/4 (12)	10,5	69,4	3 x M10x30	38x2,5	WP-3-LK56-G12-W3-K
4350	2.20	1.34	.53	3.31	2.95	.87	1.06	1.85		.41	152.68			
300	56	34	13,5	84	75	27	27	47	1 (16)	10,5	60,7	3 x M10x30	38x2,5	WP-3-LK56-G16-W3-K
4350	2.20	1.34	.53	3.31	2.95	1.06	1.06	1.85		.41	133.54			

¹ The maximum working pressure PN (bar/PSI) applies only to the flange itself. The actual maximum working pressure depends on the thickness and the quality of the tube used.

Materials / Ordering Options / Examples

* Kit with 3-Hole Flange made of Steel S355J0 or equivalent, zinc/nickel-plated including Metric bolts 8.8, spring rings, O-ring made of NBR (Buna-N®)

WP-3-LK...-G**-W3-K

Please always indicate ØLK and Thread Size.



**4-Hole 90° Flange with Female BSPP Thread
Type WP-LK-G**

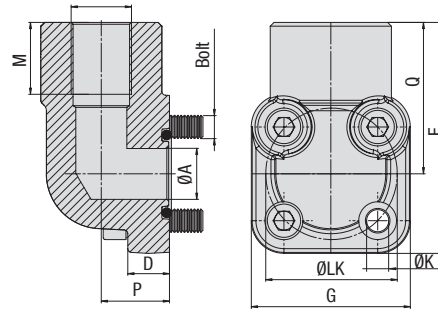

F

PN ¹ (bar/PSI)	Dimensions (mm/in)									T (BSPP)	ØK	Weight (^{kg} /lbs) ca. per 100	Bolts Metric	O-ring	Ordering Codes
	ØLK	ØA	D	F	G	M	P	Q							
300	35	13,5	11	61	42	19	18	40	3/8 (06)	6,5	33,1	2 x M6x20	19x2,5	WP-LK35-G06-W3-K	
4350	1.38	.53	.43	2.40	1.65	.75	.71	1.57		.26	72.82	2 x M6x35			
300	35	13,5	11	61	42	19	18	40	1/2 (08)	6,5	32,3	2 x M6x20	19x2,5	WP-LK35-G08-W3-K	
4350	1.38	.53	.43	2.40	1.65	.75	.71	1.57		.26	71.06	2 x M6x35			
300	40	20	10	67,5	45	19	24	45	1/2 (08)	6,5	38,3	2 x M6x25	24x2,5	WP-LK40-G08-W3-K	
4350	1.57	.79	.39	2.66	1.77	.75	.94	1.77		.26	84.26	2 x M6x45			
300	40	20	10	67,5	45	20	24	45	3/4 (12)	6,5	35,7	2 x M6x25	24x2,5	WP-LK40-G12-W3-K	
4350	1.57	.79	.39	2.66	1.77	.79	.94	1.77		.26	78.49	2 x M6x45			
300	40	20	10	67,5	45	22	24	45	1 (16)	6,5	48,3	3 x M6x25	24x2,5	WP-LK40-G16-W3-K	
4350	1.57	.79	.39	2.66	1.77	.87	.94	1.77		.26	106.26	2 x M6x55			
250	55	25	13	83,5	59	22	35	54	1 (16)	8,5	82,3	2 x M8x25	32x2,5	WP-LK55-G16-W3-K	
3625	2.17	.98	.51	3.29	2.32	.87	1.38	2.13		.33	181.06	2 x M8x60			
250	55	25	13	83,5	59	25	35	54	1-1/4 (20)	8,5	107,2	3 x M8x25	32x2,5	WP-LK55-G20-W3-K	
3625	2.17	.98	.51	3.29	2.32	.98	1.38	2.13		.33	235.84	2 x M8x70			

Materials / Ordering Options / Examples

* Kit with 4-Hole Flange made of Steel S355J0 or equivalent, zinc/nickel-plated including Metric bolts 8.8, spring rings, O-ring made of NBR (Buna-N®)

WP-LK...-G**-W3-K

Please always indicate ØLK and Thread Size.

¹ The maximum working pressure PN (bar/PSI) applies only to the flange itself. The actual maximum working pressure depends on the thickness and the quality of the tube used.

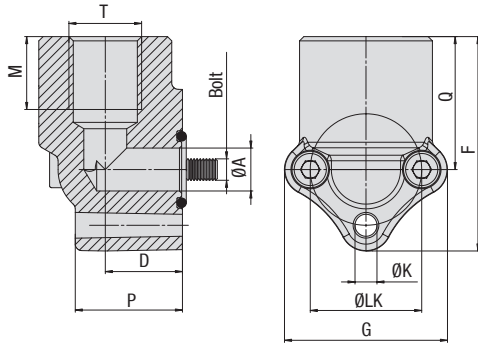

**3-Hole 90° Flange with Female BSPP Thread (Aluminium)
Type WP-3-LK-G-W50**

PN ¹ (bar/PSI)	Dimensions (mm/in)										Weight (kg/lbs) ca. per 100	Bolts Metric	O-ring	Ordering Codes
	ØLK	ØA	D	F	G	M	P	Q	T (BSPP)	ØK				
180	26	10	25	50	38	17	18	31	3/8 (06)	6	9,1	3 x M5x35	14x1,78	WP-3-LK26-G06-W50-K
2610	1.02	.39	.98	1.97	1.50	.67	.71	1.22		.24	20.02			
180	26	10	25	50	38	18	18	31	1/2 (08)	6	8,6	3 x M5x35	14x1,78	WP-3-LK26-G08-W50-K
2610	1.02	.39	.98	1.97	1.50	.71	.71	1.22		.24	18.92			
180	30	12,5	26	53	40	17	18	31	3/8 (06)	7	12,0	3 x M6x35	15,88x2,62	WP-3-LK30-G06-W50-K
2610	1.18	.49	1.02	2.09	1.57	.67	.71	1.22		.28	26.40			
180	30	12,5	26	53	44	18	18	31	1/2 (08)	7	11,2	3 x M6x35	15,88x2,62	WP-3-LK30-G08-W50-K
2610	1.18	.49	1.02	2.09	1.73	.71	.71	1.22		.28	24.64			
180	40	18	31	68	56	18	21,5	40	1/2 (08)	9,5	24,0	3 x M8x45	21,89x2,62	WP-3-LK40-G08-W50-K
2610	1.57	.71	1.22	2.68	2.20	.71	.85	1.57		.37	52.80			
180	40	18	31	68	56	22	21,5	40	3/4 (12)	9,5	22,8	3 x M8x45	21,89x2,62	WP-3-LK40-G12-W50-K
2610	1.57	.71	1.22	2.68	2.20	.87	.85	1.57		.37	50.16			
180	51-56	24,5	42	85	78	22	26	46	3/4 (12)	11	49,8	3 x M10x60	29,74x2,62	WP-3-LK51-G12-W50-K
2610	2.01-2.20	.96	1.65	3.35	3.07	.87	1.02	1.81		.43	109.56			
180	51-56	24,5	42	85	78	27	26	46	1 (16)	11	46,4	3 x M10x60	29,74x2,62	WP-3-LK51-G16-W50-K
2610	2.01-2.20	.96	1.65	3.35	3.07	1.06	1.02	1.81		.43	102.08			

¹ The maximum working pressure PN (bar/PSI) applies only to the flange itself. The actual maximum working pressure depends on the thickness and the quality of the tube used.

Materials / Ordering Options / Examples

* Kit with 3-Hole Flange made of Aluminium [EN AC-Al Si9Cu(Fe)] including Metric bolts 8.8, spring rings, O-ring made of NBR (Buna-N®)

WP-3-LK...-G**-W50-K

Please always indicate ØLK and Thread Size.



**4-Hole 90° Flange with Female BSPP Thread (Aluminium)
Type WP-LK-G-W50**

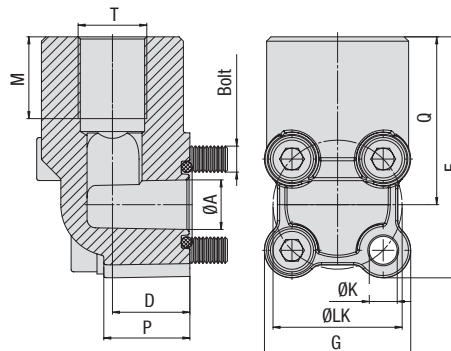

PN ¹ (bar/PSI)	Dimensions (mm/in)									Weight (^{kg} /lbs) ca. per 100	Bolts Metric	O-ring	Ordering Codes	
	ØLK	ØA	D	F	G	M	P	Q	T (BSPP)					
180	30	11,5	20	56	34	19	18	39	3/8 (06)	6,5	14,3	2 x M6x30	15,88x2,62	WP-LK30-G06-W50-K
2610	1.18	.45	.79	2.20	1.34	.75	.71	1.54		.26	31.46	2 x M6x40		
180	30	11,5	20	56	34	19	18	39	1/2 (08)	6,5	13,8	2 x M6x30	15,88x2,62	WP-LK30-G08-W50-K
2610	1.18	.45	.79	2.20	1.34	.75	.71	1.54		.26	30.36	2 x M6x40		
180	35	14	20	61,5	38	19	18	42,5	3/8 (06)	6,5	85,8	2 x M6x30	18,72x2,62	WP-LK35-G06-W50-K
2610	1.38	.55	.79	2.42	1.50	.75	.71	1.67		.26	188.76	2 x M6x40		
180	35	14	20	61,5	38	19	18	42,5	1/2 (08)	6,5	14,2	2 x M6x30	18,72x2,62	WP-LK35-G08-W50-K
2610	1.38	.55	.79	2.42	1.50	.75	.71	1.67		.26	31.24	2 x M6x40		
180	40	18	28	69	43	19	24	47,5	1/2 (08)	6,5	21,8	2 x M6x40	21,89x2,62	WP-LK40-G08-W50-K
2610	1.57	.71	1.10	2.72	1.69	.75	.94	1.87		.26	47.96	2 x M6x50		
180	40	18	28	69	43	20	24	47,5	3/4 (12)	6,5	22,0	2 x M6x40	21,89x2,62	WP-LK40-G12-W50-K
2610	1.57	.71	1.10	2.72	1.69	.79	.94	1.87		.26	48.40	2 x M6x50		
180	55	24,5	31	83	58	20	29	54	3/4 (12)	8,5	42,4	2 x M8x45	29,74x2,62	WP-LK55-G12-W50-K
2610	2.17	.96	1.22	3.27	2.28	.79	1.14	2.13		.33	93.28	2 x M8x60		
180	55	24,5	31	83	58	22	29	54	1 (16)	8,5	41,0	2 x M8x45	29,74x2,62	WP-LK55-G16-W50-K
2610	2.17	.96	1.22	3.27	2.28	.87	1.14	2.13		.33	90.20	2 x M8x60		

F

Materials / Ordering Options / Examples

* Kit with 4-Hole Flange made of Aluminium [EN AC-Al Si9Cu(Fe)] including Metric bolts 8.8, spring rings, O-ring made of NBR (Buna-N®)

WP-LK...-G**-W50-K

Please always indicate ØLK and Thread Size.

¹ The maximum working pressure PN (bar/PSI) applies only to the flange itself. The actual maximum working pressure depends on the thickness and the quality of the tube used.

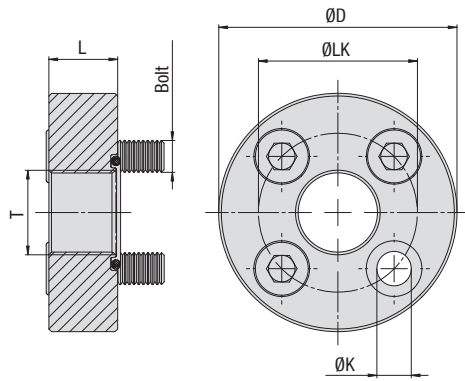

**4-Hole Flange with Female BSPP Thread (Flat Style)
Type GP-FL-LK-G**

PN ¹ (bar/PSI)	Dimensions (mm/in)		L	T (BSPP)	ØK	Weight (kg/lbs) ca. per 100	Bolts Metric	O-ring	Ordering Codes
	ØLK	ØD							
250	30	45	13	3/8 (06)	6,5	14,3	M6x16	18,77x1,78	GP-FL-LK30-G06-W129-K
3625	1.18	1.77	.51		.26	31.46			
250	40	58	15	1/2 (08)	8,5	27,4	M8x20	25,12x1,78	GP-FL-LK40-G08-W129-K
3625	1.57	2.28	.59		.33	60.28			
250	51	75	18	3/4 (12)	10,5	55,3	M10x25	31,42x2,62	GP-FL-LK51-G12-W129-K
3625	2.01	2.95	.71		.41	121.66			
250	56	75	18	3/4 (12)	10,5	55,4	M10x25	31,42x2,62	GP-FL-LK56-G12-W129-K
3625	2.20	2.95	.71		.41	121.88			
180	62	88	20	1 (16)	10,5	82,0	M10x25	39,69x3,53	GP-FL-LK62-G16-W129-K
2610	2.44	3.46	.79		.41	180.40			
180	62	88	20	1 (16)	12,5	81,5	M12x25	39,69x3,53	GP-FL-LK62-G16-M12-W129-K
2610	2.44	3.46	.79		.49	179.30			
180	72,5	98	22	1-1/4 (20)	12,5	106,6	M12x30	47,22x3,53	GP-FL-LK72.5-G20-W129-K
2610	2.85	3.86	.87		.49	234.52			

F

¹ The maximum working pressure PN (bar/PSI) applies only to the flange itself. The actual maximum working pressure depends on the thickness and the quality of the tube used.

Materials / Ordering Options / Examples

* Kit with 4-Hole Flange made of Steel S355J0 or equivalent, zinc-plated and thick-film-passivated GP-LK...-G**-W129-K including Metric bolts 8.8, spring rings, O-ring made of NBR (Buna-N®)

Please always indicate ØLK and Thread Size.



**4-Hole Butt-Weld Flange
Type GP-LK-ST**

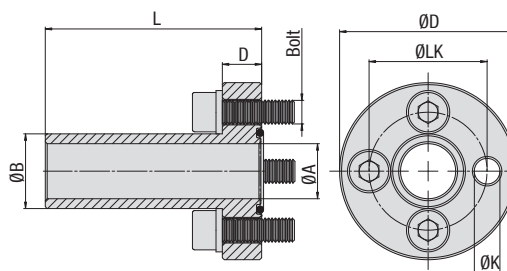

PN ¹ (bar/PSI)	Dimensions (mm/in)							Weight (kg/lbs) ca. per 100	Bolts Metric	O-ring	Ordering Codes
	ØLK	ØA	ØB	D	ØD	L	ØK				
8.8											
250	30	14	19	10	45	55	6,5	17,9	M6x20	18,77x1,78	GP-LK30-ST-19/14-W1-K
3625	1.18	.55	.75	.39	1.77	2.17	.26	39.38			
250	40	19	25,4	12	58	60	8,5	34,9	M8x25	25,12x1,78	GP-LK40-ST-25.4/19-W1-K
3625	1.57	.75	1.00	.47	2.28	2.36	.33	76.78			
250	51	24,5	32	16	76	72	10,5	74,4	M10x35	31,42x2,62	GP-LK51-ST-32/24.5-W1-K
3625	2.01	.96	1.26	.63	2.99	2.83	.41	163.68			
250	56	24,5	32	16	76	72	10,5	74,2	M10x35	31,42x2,62	GP-LK56-ST-32/24.5-W1-K
3625	2.20	.96	1.26	.63	2.99	2.83	.41	163.24			

F

Materials / Ordering Options / Examples

* Kit with 4-Hole Flange made of Steel S355J0 or equivalent, blank (oiled) including Metric bolts 8.8, spring rings, O-ring made of NBR (Buna-N®)

GP-LK...-ST-*/**-W1-K

Please always indicate ØLK, ØB and ØA.

¹ The maximum working pressure PN (bar/PSI) applies only to the flange itself. The actual maximum working pressure depends on the thickness and the quality of the tube used.



**4-Hole Flange with Male BSPP Thread and 60° Conical Bore (acc. to BS 5200)
Type GP-LK-B**

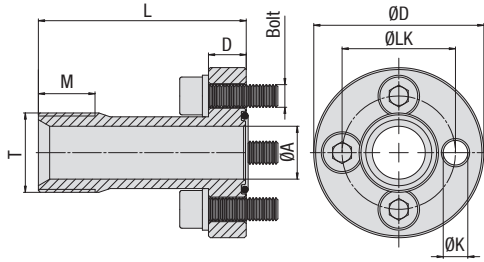

PN ¹ (bar/PSI)	Dimensions (mm/in)								Weight (kg/lbs) ca. per 100	Bolts Metric	O-ring	Ordering Codes
	ØLK	ØA	D	ØD	L	M	T (BSPP)	ØK				
8.8	30	14	10	45	55	15	1/2 (08)	6,5	17,1	M6x20	18,77x1,78	GP-LK30-B08-W129-K
3625	1.18	.55	.39	1.77	2.17	.59		.26	37.62			
250	40	19	12	58	60	16	3/4 (12)	8,5	33,8	M8x25	25,12x1,78	GP-LK40-B12-W129-K
3625	1.57	.75	.47	2.28	2.36	.63		.33	74.36			
250	51	24	16	76	72	19	1 (16)	10,5	71,3	M10x35	31,42x2,62	GP-LK51-B16-W129-K
3625	2.01	.94	.63	2.99	2.83	.75		.41	156.86			
250	56	24	16	76	72	19	1 (16)	10,5	71,5	M10x35	31,42x2,62	GP-LK56-B16-W129-K
3625	2.20	.94	.63	2.99	2.83	.75		.41	157.30			

F

¹ The maximum working pressure PN (bar/PSI) applies only to the flange itself. The actual maximum working pressure depends on the thickness and the quality of the tube used.

Materials / Ordering Options / Examples

* Kit with 4-Hole Flange made of Steel S355J0 or equivalent, zinc-plated and thick-film-passivated **GP-LK...-B**-W129-K** including Metric bolts 8.8, spring rings, O-ring made of NBR (Buna-N®)

Please always indicate ØLK and Thread Size.



**4-Hole Flange with Female BSPP Thread
Type GP-LK-G**

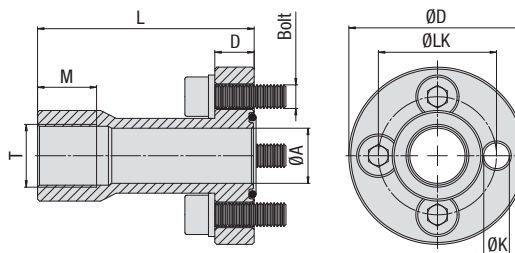

PN ¹ (bar/PSI)	Dimensions (mm/in)		D	ØD	L	M	T (BSPP)	ØK	Weight (kg/lbs) ca. per 100	Bolts Metric	O-ring	Ordering Codes
	8.8	ØLK										
250	30	14	10	45	55	15	3/8 (06)	6,5	18,7	M6x20	18,77x1,78	GP-LK30-G06-W129-K
3625	1.18	.55	.39	1.77	2.17	.59	1/2 (08)	.26	41.14	M8x25	25,12x1,78	GP-LK40-G08-W129-K
250	40	19	12	58	60	16		8,5	35,4			
3625	1.57	.75	.47	2.28	2.36	.63	3/4 (12)	.33	77.88	M10x35	31,42x2,62	GP-LK51-G12-W129-K
250	51	24,5	16	76	72	19		10,5	74,1			
3625	2.01	.96	.63	2.99	2.83	.75	3/4 (12)	.41	163.02	M10x35	31,42x2,62	GP-LK56-G12-W129-K
250	56	24,5	16	76	72	19		10,5	74,3			
3625	2.20	.96	.63	2.99	2.83	.75		.41	163.46			

F

Materials / Ordering Options / Examples

* Kit with 4-Hole Flange made of Steel S355J0 or equivalent, zinc-plated and thick-film-passivated **GP-LK...-G**-W129-K** including Metric bolts 8.8, spring rings, O-ring made of NBR (Buna-N®)

Please always indicate ØLK and Thread Size.

¹ The maximum working pressure PN (bar/PSI) applies only to the flange itself. The actual maximum working pressure depends on the thickness and the quality of the tube used.



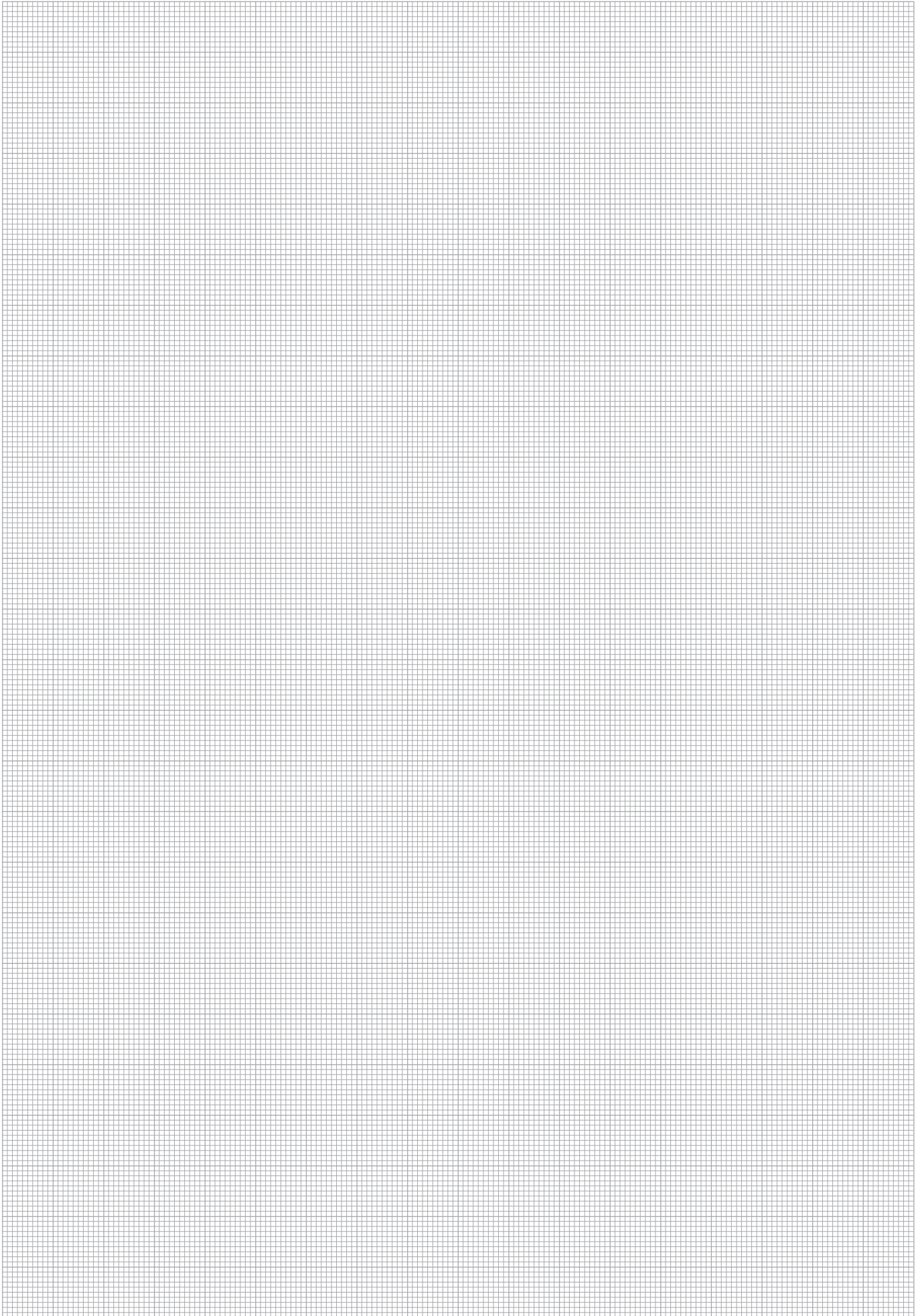

F





Assembly Instructions for SAE Flanges	114
Property Classes of Bolts	115
Tightening Torques	115
Sizing Guide for SAE Flanges	116



Assembly Instructions for SAE Flanges

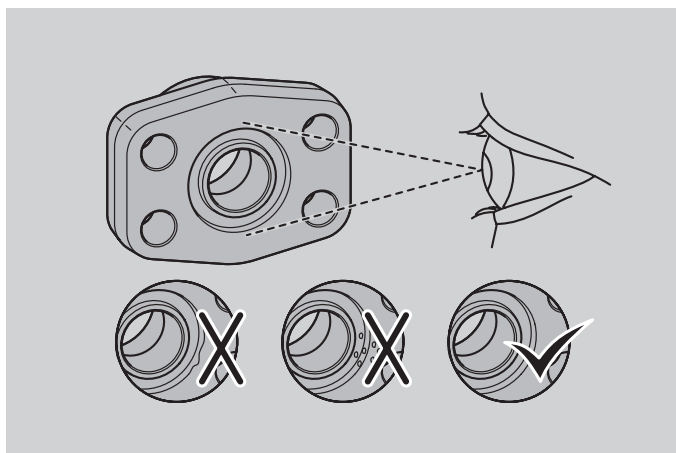

Check the sealing surface and the o-ring groove of the flange for visible damage (scratches, cracks, notches, sharp edges or burrs) and make sure that both are free of contamination and any foreign particles. Circular machining marks up to a surface roughness of Ra max 3,2 (ISO 1302) are acceptable and do not influence the performance of the flange connection.

Scratches with a width greater than 0,13 mm (.0005 in) running perpendicular, radial, or spiral on the sealing surface or in the o-ring groove are not acceptable.

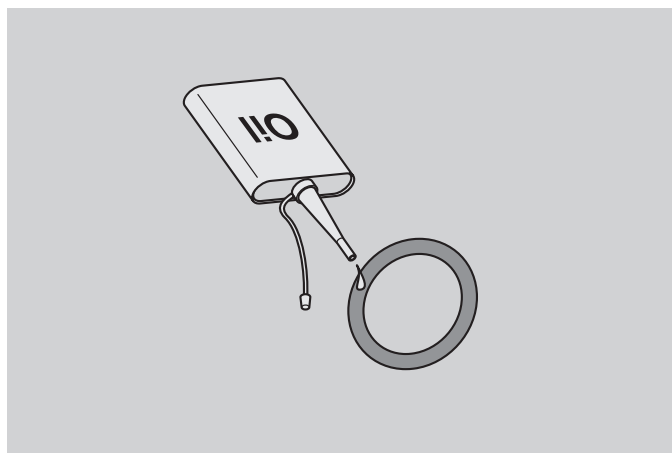

Lubricate the o-ring using the system fluid (or a compatible lubricant) and immediately proceed with the assembly in order to avoid exposure to contamination.

Do not use lubricating grease!

G

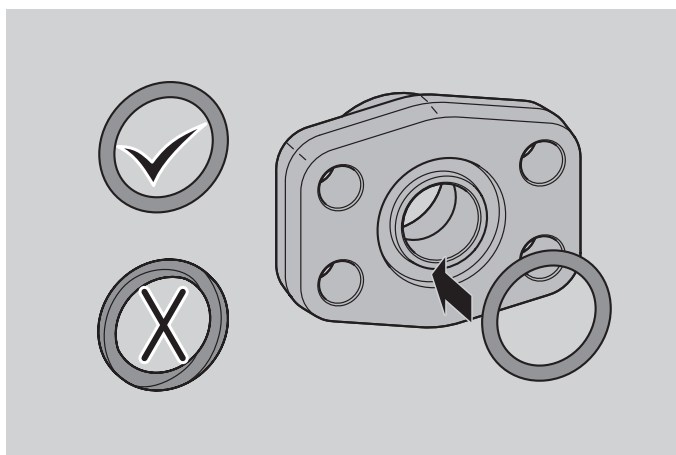

Place the o-ring into the o-ring groove, making sure that it is not twisted.

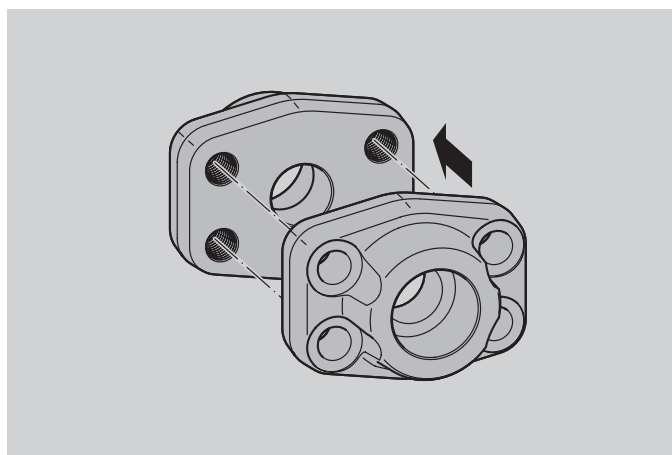

Position the flange against the mating component.

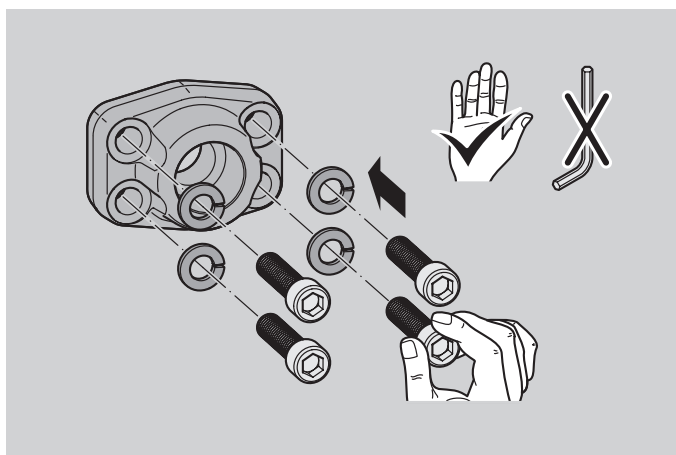

Place the socket head screws (with spring washers) into the flange and hand-tighten.

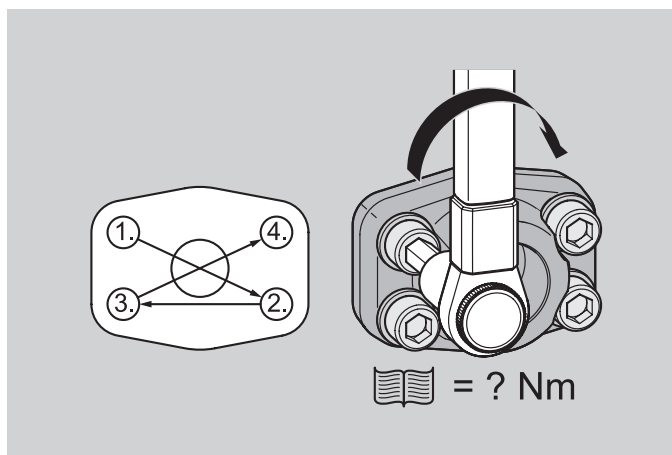

Finish the assembly by gradually tightening the socket head screws in small increments and in the displayed sequence to the appropriate torque level (see table on the right).



Property Classes of Bolts and Tightening Torques

Bolts 8.8 M (Metric Standard)

3000 PSI Standard Pressure Series (according to ISO 6162-1:2002)

Nominal Size		Bolt Size	Tightening Torques ^{+10%}		Working Pressure max		Burst Pressure min	
ISO	SAE		(Nm)	(ft-lb)	(bar)	(PSI)	(bar)	(PSI)
13	1/2	M8	24	17.8	350	5075	1400	20300
19	3/4	M10	50	37.0	350	5075	1400	20300
25	1	M10	50	37.0	250	3625	1000	14500
32	1-1/4	M10	50	37.0	200	2900	800	11600
38	1-1/2	M12	92	68.1	200	2900	800	11600
51	2	M12	92	68.1	160	2320	640	9280
64	2-1/2	M12	92	68.1	100	1450	400	5800
76	3	M16	210	155.4	100	1450	400	5800
89	3-1/2	M16	210	155.4	35	508	140	2030
102	4	M16	210	155.4	35	508	140	2030
127	5	M16	210	155.4	35	508	140	2030

Bolts 10.9 MH (Metric High)

3000 PSI Standard Pressure Series (according to ISO 6162-1:2002)

Nominal Size		Bolt Size	Tightening Torques ^{+10%}		Working Pressure max		Burst Pressure min	
ISO	SAE		(Nm)	(ft-lb)	(bar)	(PSI)	(bar)	(PSI)
13	1/2	M8	32	23.7	350	5075	1400	20300
19	3/4	M10	70	51.8	350	5075	1400	20300
25	1	M10	70	51.8	315	4568	1260	18270
32	1-1/4	M10	70	51.8	250	3625	1000	14500
38	1-1/2	M12	130	96.2	200	2900	800	11600
51	2	M12	130	96.2	200	2900	800	11600
64	2-1/2	M12	130	96.2	160	2320	640	9280
76	3	M16	295	218.3	160	2320	640	9280
89	3-1/2	M16	295	218.3	35	508	140	2030
102	4	M16	295	218.3	35	508	140	2030
127	5	M16	295	218.3	35	508	140	2030

6000 PSI High Pressure Series (according to ISO 6162-2:2002)

Nominal Size		Bolt Size	Tightening Torques ^{+10%}		Working Pressure max		Burst Pressure min	
ISO	SAE		(Nm)	(ft-lb)	(bar)	(PSI)	(bar)	(PSI)
13	1/2	M8	24	17.8	350	5075	1400	20300
19	3/4	M10	50	37.0	350	5075	1400	20300
25	1	M12	92	68.1	350	5075	1400	20300
32	1-1/4	M12	92	68.1	350	5075	1400	20300
32	1-1/4	M14 ¹	130	96.2	350	5075	1400	20300
38	1-1/2	M16	210	155.4	350	5075	1400	20300
51	2	M20	400	296.0	350	5075	1400	20300

6000 PSI High Pressure Series (according to ISO 6162-2:2002)

Nominal Size		Bolt Size	Tightening Torques ^{+10%}		Working Pressure max		Burst Pressure min	
ISO	SAE		(Nm)	(ft-lb)	(bar)	(PSI)	(bar)	(PSI)
13	1/2	M8	32	23.7	400	5800	1600	23200
19	3/4	M10	70	51.8	400	5800	1600	23200
25	1	M12	130	96.2	400	5800	1600	23200
32	1-1/4	M12	130	96.2	400	5800	1600	23200
32	1-1/4	M14 ¹	180	133.2	400	5800	1600	23200
38	1-1/2	M16	295	218.3	400	5800	1600	23200
51	2	M20	550	407.0	400	5800	1600	23200

Bolts Gr8 U (UNC)

3000 PSI Standard Pressure Series (according to ISO 6162-1:2002)

Nominal Size		Bolt Size	Tightening Torques ^{+10%}		Working Pressure max		Burst Pressure min	
ISO	SAE		(Nm)	(ft-lb)	(bar)	(PSI)	(bar)	(PSI)
13	1/2	5/16-18 UNC	32	23.7	350	5075	1400	20300
19	3/4	3/8-16 UNC	60	44.4	350	5075	1400	20300
25	1	3/8-16 UNC	60	44.4	315	4568	1260	18270
32	1-1/4	7/16-14 UNC	92	68.1	250	3625	1000	14500
38	1-1/2	1/2-13 UNC	150	111.0	200	2900	800	11600
51	2	1/2-13 UNC	150	111.0	200	2900	800	11600
64	2-1/2	1/2-13 UNC	150	111.0	160	2320	640	9280
76	3	5/8-11 UNC	295	218.3	160	2320	640	9280
89	3-1/2	5/8-11 UNC	295	218.3	35	508	140	2030
102	4	5/8-11 UNC	295	218.3	35	508	140	2030
127	5	5/8-11 UNC	295	218.3	35	508	140	2030

6000 PSI High Pressure Series (according to ISO 6162-2:2002)

Nominal Size		Bolt Size	Tightening Torques ^{+10%}		Working Pressure max		Burst Pressure min	
ISO	SAE		(Nm)	(ft-lb)	(bar)	(PSI)	(bar)	(PSI)
13	1/2	5/16-18 UNC	32	23.7	400	5800	1600	23200
19	3/4	3/8-16 UNC	60	44.4	400	5800	1600	23200
25	1	7/16-14 UNC	92	68.1	400	5800	1600	23200
32	1-1/4	1/2-13 UNC	150	111.0	400	5800	1600	23200
38	1-1/2	5/8-11 UNC	295	218.3	400	5800	1600	23200
51	2	3/4-10 UNC	450	333.0	400	5800	1600	23200

Notes

¹ Not to be used for new designs.

Attention:

All bolts have to be pre-tightened before applying the full tightening torque to the bolts. Otherwise, the flange may break.

Please note that the tightening torques as stated on this page are only recommendations. These values correspond to oiled bolts with a friction coefficient of 0.17 and the material combination Steel/Steel.

The exact tightening torques depend on factors like material, finishing, coating and lubrication of the components used, and have to be determined by the user himself.

Please contact STAUFF prior to the assembly for torque recommendations for alternative mating materials.

G



Sizing Guide for SAE Flanges
3000 PSI Standard Pressure Series

Nominal Size SAE	Dimensions (mm/in)			Metric Threads
	H	I	ØK	
1/2	17,5	38,1	8,7	M8
	.69	1,50	.34	
3/4	22,3	47,6	1,5	M10
	.88	1,87	.41	
1	26,2	52,4	1,5	M10
	1,03	2,06	.41	
1-1/4	3,2	58,7	1,5 / 12,5	M10 / M12
	1,19	2,31	.41 / .49	
1-1/2	35,7	69,9	13,5 / 14,5	M12 / M14
	1,41	2,75	.53 / .57	
2	42,9	77,8	13,5 / 14,5	M12 / M14
	1,69	3,06	.53 / .57	
2-1/2	5,8	88,9	13,5 / 14,5	M12 / M14
	2,00	3,50	.53 / .57	
3	61,9	106,4	17	M16
	2,44	4,19	.67	
3-1/2	69,9	12,7	17	M16
	2,75	4,75	.67	
4	77,8	13,2	17	M16
	3,06	5,13	.67	
5	92,1	152,4	17	M16
	3,63	6,00	.67	

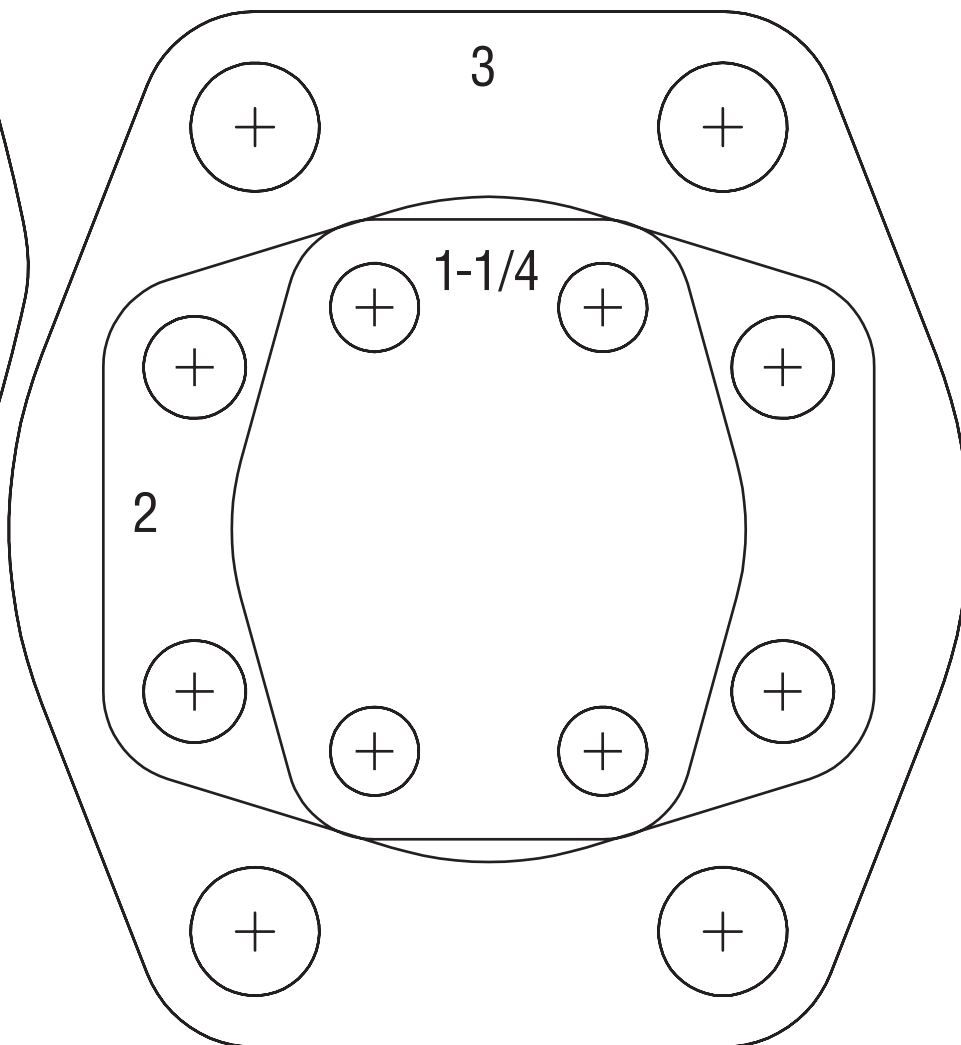
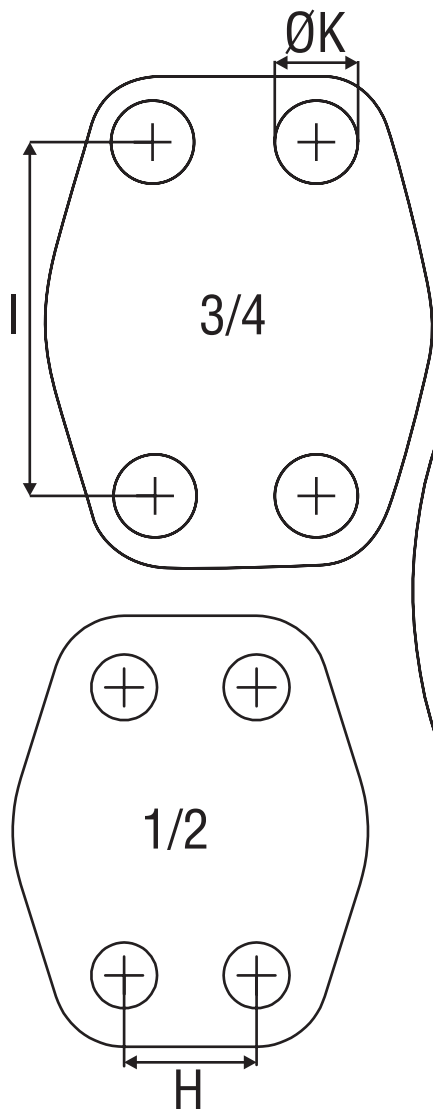
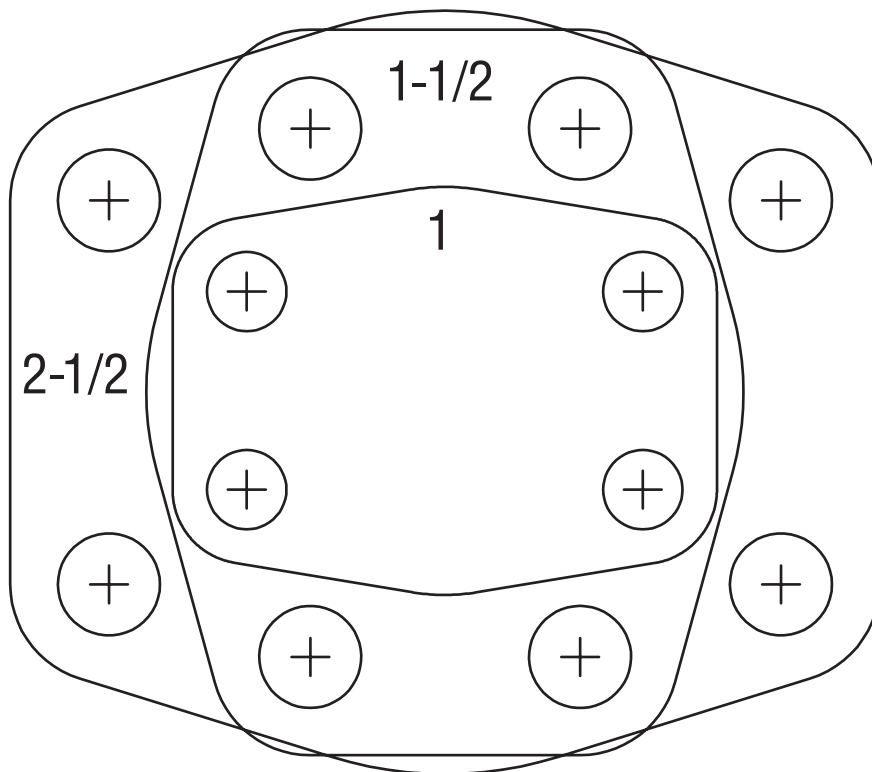

G



Sizing Guide for SAE Flanges
 6000 PSI High Pressure Series

Nominal Size SAE	Dimensions (mm/in)			Metric Threads
	H	I	ØK	
1/2	18,2	40,5	8,7	M8
	.72	1.59	.34	
3/4	23,8	50,8	10,5	M10
	.94	2.00	.41	
1	27,8	57,2	13	M12
	1.09	2.25	.51	
1-1/4	31,8	66,6	13,5 / 15,0	M12 / M14
	1.25	2.62	.53 / .59	
1-1/2	36,5	79,3	17	M16
	1.44	3.12	.67	
2	44,5	96,8	21	M20
	1.75	3.81	.83	

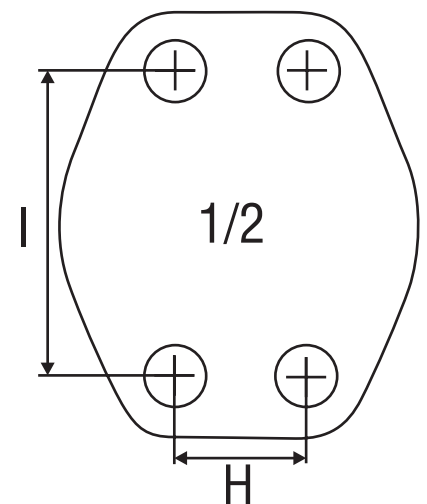
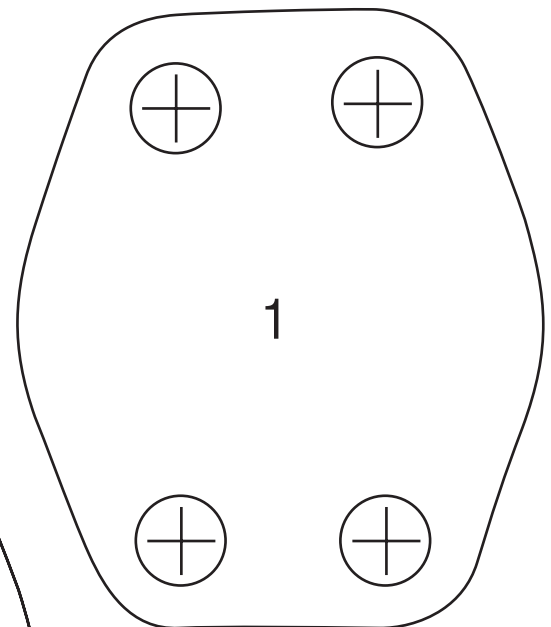
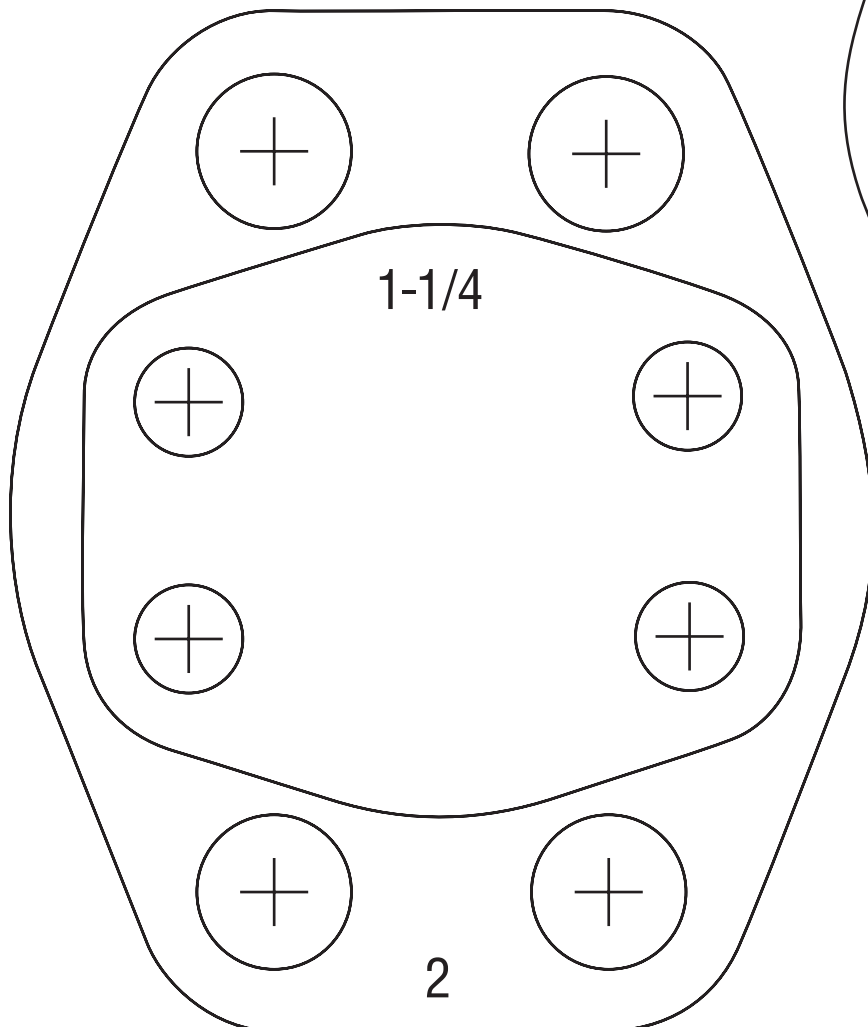
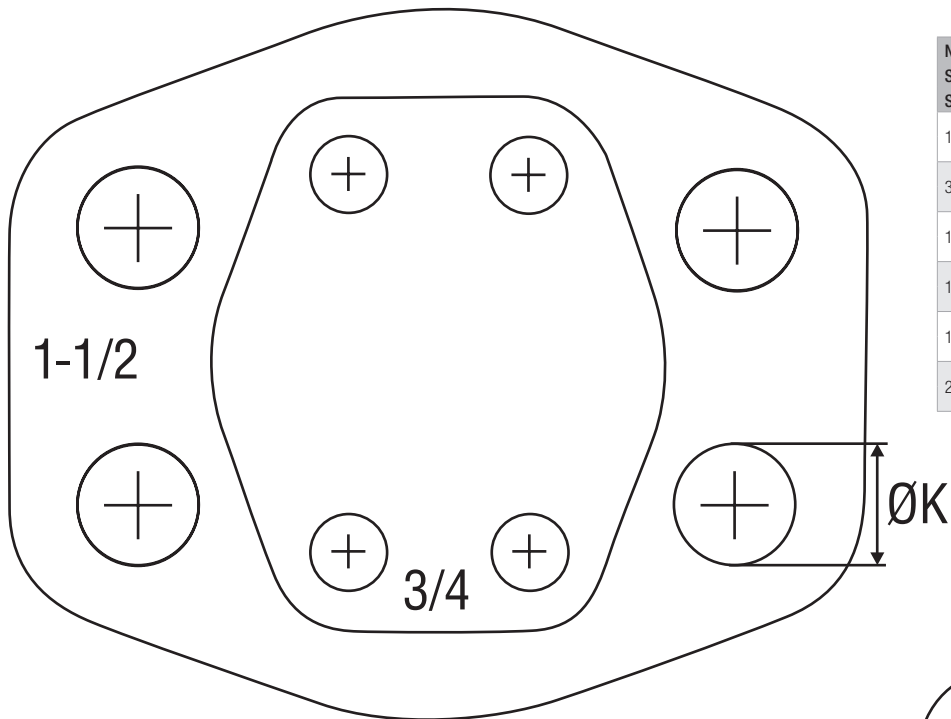

G





Product-Specific Abbreviations	120
---------------------------------------	------------

Global Contact Directory	122
---------------------------------	------------



Product-Specific Abbreviations

Abbreviation	Product Category	Product Description	Page
BAS-CP	Accessories for SAE Flanges	SAE Single-Part Blanking Counterflange	83
BAS-ES	SAE Flange / Counterflange Adaptors	SAE Single-Part Socket-Weld Counterflange	62
BAS-FL-ES	SAE Flange / Counterflange Adaptors	SAE Single-Part Socket-Weld Counterflange (Flat Style)	65
BAS-G	SAE Flange / Counterflange Adaptors	SAE Single-Part Counterflange with Female BSPP Thread	42
BAS-N	SAE Flange / Counterflange Adaptors	SAE Single-Part Counterflange with Female NPT Thread	46
BAS-SRE	SAE Flange / Counterflange Adaptors	SAE Single-Part Butt-Weld Counterflange for Metric Tubes	58
BAS-ST	SAE Flange / Counterflange Adaptors	SAE Single-Part Butt-Weld Counterflange for High Pressure Tubes	52
BAS-STRE	SAE Flange / Counterflange Adaptors	SAE Single-Part Butt-Weld Counterflange for Low Pressure Tubes	55
BC-L	SAE Flange Blocks	SAE Block L-Connection (Connector Style)	95
BC-T	SAE Flange Blocks	SAE Block T-Connection (Connector Style)	93
BF-L	SAE Flange Blocks	SAE Block L-Connection (Adaptor Style)	94
BF-L	SAE Flange Blocks	SAE Block L-Connection Reduction (Adaptor Style)	96
BF-T	SAE Flange Blocks	SAE Block T-Connection (Adaptor Style)	92
BFX90-ES	SAE Flange / Counterflange Adaptors	SAE 90° Single-Part Socket-Weld Flange	76
BFX90-G	SAE Flange / Counterflange Adaptors	SAE 90° Single-Part Flange with Female BSPP Thread	71
BFX90-L/S	SAE Flange / Counterflange Adaptors	SAE 90° Single-Part Flange with Male Metric Thread and 24° Conical Bore (Shape W acc. to DIN 3861)	78
BFX90-N	SAE Flange / Counterflange Adaptors	SAE 90° Single-Part Flange with Female NPT Thread	72
BFX90-SRE	SAE Flange / Counterflange Adaptors	SAE 90° Single-Part Butt-Weld Flange for Metric Tubes	74
BFX90-STC	SAE Flange / Counterflange Adaptors	SAE 90° Single-Part Butt-Weld Flange for High Pressure Tubes	73
BFX-B	SAE Flange / Counterflange Adaptors	SAE Single-Part Flange with Male BSPP Thread and 60° Conical Bore (acc. to BS 5200)	68
BFX-BAS	Accessories for SAE Flanges	SAE Reducing Flange	88
BFX-CP	Accessories for SAE Flanges	SAE Single-Part Blanking Flange	82
BFX-ES	SAE Flange / Counterflange Adaptors	SAE Single-Part Socket-Weld Flange	60
BFX-FL-ES	SAE Flange / Counterflange Adaptors	SAE Single-Part Socket-Weld Flange (Flat Style)	64
BFX-G	SAE Flange / Counterflange Adaptors	SAE Single-Part Flange with Female BSPP Thread	40
BFX-J	SAE Flange / Counterflange Adaptors	SAE Single-Part Flange with Male UN/UNF Thread and 37° JIC Taper (acc. to ISO 8434-2 / SAE J514)	70
BFX-L/S	SAE Flange / Counterflange Adaptors	SAE Single-Part Flange with Male Metric Thread and 24° Conical Bore (Shape W acc. to DIN 3861)	66
BFX-N	SAE Flange / Counterflange Adaptors	SAE Single-Part Flange with Female NPT Thread	44
BFX-SRE	SAE Flange / Counterflange Adaptors	SAE Single-Part Butt-Weld Flange for Metric Tubes	56
BFX-ST	SAE Flange / Counterflange Adaptors	SAE Single-Part Butt-Weld Flange for High Pressure Tubes	50
BFX-STRE	SAE Flange / Counterflange Adaptors	SAE Single-Part Butt-Weld Flange for Low Pressure Tubes	54
BFX-U	SAE Flange / Counterflange Adaptors	SAE Single-Part Flange with Female UN/UNF Thread	48
BM	SAE Split Flange Halves / Flange Clamps	SAE Flange Clamp	16
BM-FL	SAE Split Flange Halves / Flange Clamps	SAE Flange Clamp (Flat Style)	19
BM-G	SAE Split Flange Halves / Flange Clamps	SAE Flange Clamp with Metric Tapped Holes	20
CAG90-L/S	SAE Single-Part Flanges / Counterflanges	SAE 90° Flange Adaptor with Male Metric Thread and 24° Conical Bore (Shape W acc. to DIN 3861)	36
CAG90-ST	SAE Single-Part Flanges / Counterflanges	SAE 90° Butt-Weld Flange Adaptor	34
CAG-BP	Accessories for SAE Flanges	SAE Blindplug (Standard)	85
CAG-BPH	Accessories for SAE Flanges	SAE Blindplug (High)	85
CAG-ES	SAE Single-Part Flanges / Counterflanges	SAE Socket-Weld Flange Adaptor	26
CAG-L/S	SAE Single-Part Flanges / Counterflanges	SAE Flange Adaptor with Male Metric Thread and 24° Conical Bore (Shape W acc. to DIN 3861)	32
CAG-N	SAE Single-Part Flanges / Counterflanges	SAE Flange Adaptor with Male NPT Thread	30
CAG-ST	SAE Single-Part Flanges / Counterflanges	SAE Butt-Weld Flange Adaptor	24
CAG-T	SAE Single-Part Flanges / Counterflanges	SAE Flange Adaptor with Male BSPT Thread	28
CPL	Accessories for SAE Flanges	SAE Cover Plate	87
CSG-ES	SAE Single-Part Flanges / Counterflanges	SAE Socket-Weld Counterflange Adaptor	26
CSG-N	SAE Single-Part Flanges / Counterflanges	SAE Counterflange Adaptor with Male NPT Thread	30
CSG-ST	SAE Single-Part Flanges / Counterflanges	SAE Butt-Weld Counterflange Adaptor	24
CSG-T	SAE Single-Part Flanges / Counterflanges	SAE Counterflange Adaptor with Male BSPT Thread	28
DB	SAE Split Flange Halves / Flange Clamps	SAE Split Flange Halves	14
DB-FL	SAE Split Flange Halves / Flange Clamps	SAE Split Flange Halves (Flat Style)	18
GP-FL-LK-G	Gear Pump Flanges	4-Hole Flange with Female BSPP Thread (Flat Style)	107
GP-LK-B	Gear Pump Flanges	4-Hole Flange with Male BSPP Thread and 60° Conical Bore (acc. to BS 5200)	109
GP-LK-G	Gear Pump Flanges	4-Hole Flange with Female BSPP Thread	110
GP-LK-L/S	Gear Pump Flanges	4-Hole Flange with Male Metric Thread and 24° Conical Bore (Shape W acc. to DIN 3861)	100
GP-LK-ST	Gear Pump Flanges	4-Hole Butt-Weld Flange	108
IS	Accessories for SAE Flanges	Socket Cap Bolt	89
KIT-BFX-IS	Accessories for SAE Flanges	Bolt Set	89
O-RING	Accessories for SAE Flanges	O-Ring	89
SPL	Accessories for SAE Flanges	SAE Sandwich Plate	86
SPL-G04-L	Accessories for SAE Flanges	SAE Sandwich Plate with Female BSPP Port	84
WP-3-LK-G	Gear Pump Flanges	3-Hole 90° Flange with Female BSPP Thread	103
WP-3-LK-G-W50	Gear Pump Flanges	3-Hole 90° Flange with Female BSPP Thread (Aluminium)	105
WP-3-LK-L/S	Gear Pump Flanges	4-Hole 90° Flange with Male Metric Thread and 24° Conical Bore (Shape W acc. to DIN 3861)	101
WP-3-LK-L/S	Gear Pump Flanges	3-Hole 90° Flange with Male Metric Thread and 24° Conical Bore (Shape W acc. to DIN 3861)	102
WP-LK-G	Gear Pump Flanges	4-Hole 90° Flange with Female BSPP Thread	104
WP-LK-G-W50	Gear Pump Flanges	4-Hole 90° Flange with Female BSPP Thread (Aluminium)	106



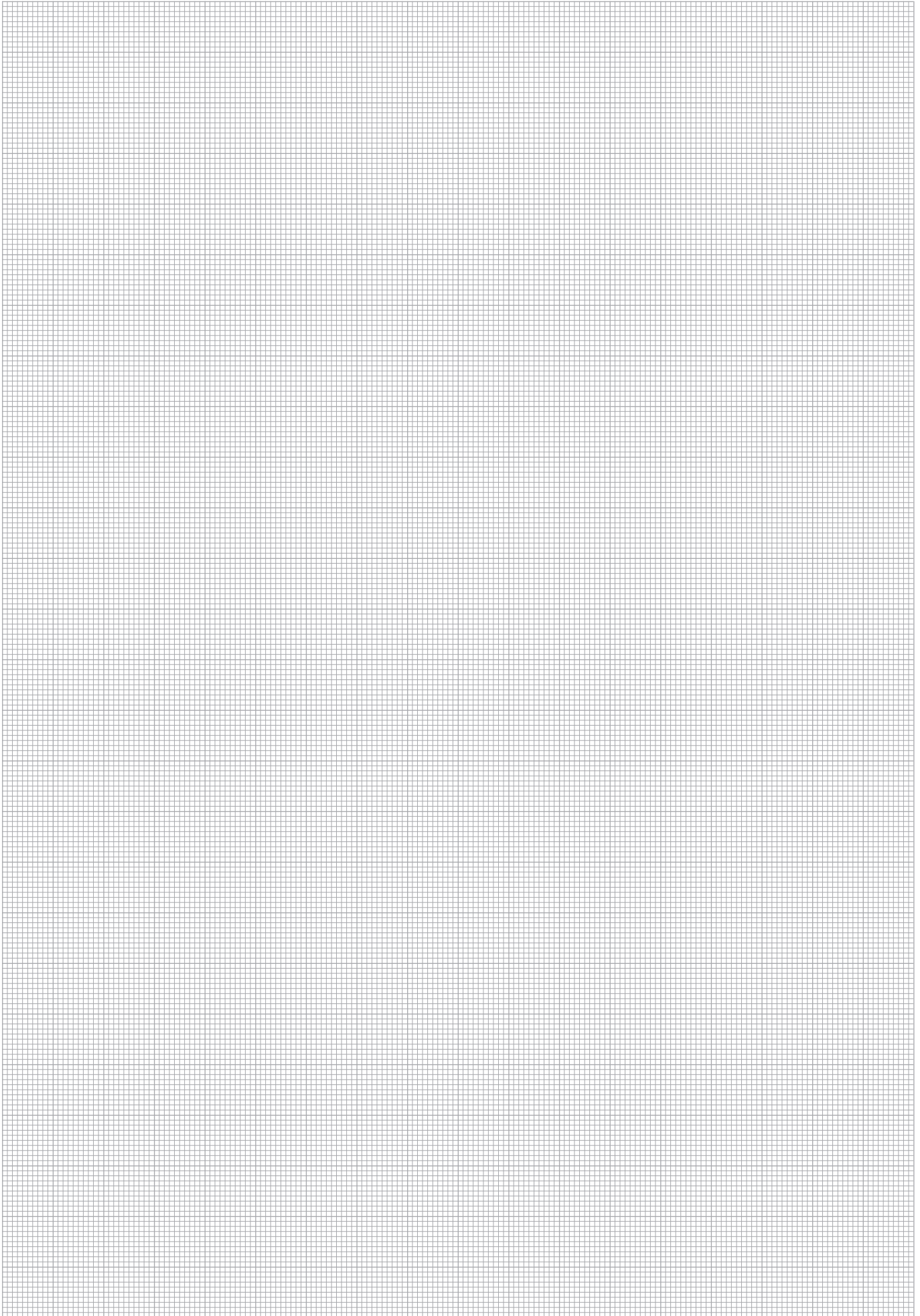

Global Contact Directory

STAUFF products and services are globally available through wholly-owned subsidiaries and a tight network of authorised distributors and representatives in all major industrial regions of the world.

Contact information on this page may be subject to changes and additions over time. Frequently updated and complete contact information can always be found at www.stauff.com.

Germany



Walter Stauffenberg GmbH & Co. KG

Im Ehrenfeld 4
58791 Werdohl
Tel.: +49 2392 91 60
Fax: +49 2392 91 61 60
E-Mail: sales@stauff.com
www.stauff.com



Neuenrade-Küntrop Logistics Centre
Wasserburgstraße 35
58809 Neuenrade



Plettenberg-Ohle Production Site
Lennastraße 2
58840 Plettenberg



Voswinkel GmbH

Neugrünenthal
58540 Meinerzhagen
Tel.: +49 2354 70 50
Fax: +49 2354 70 51 50
E-Mail: info@voswinkel.net
www.voswinkel.net

Europe

France

STAUFF S.A.S.

230, Avenue du Grain d'Or
Z.I. de Vineuil - Blois Sud
41354 Vineuil-cedex
Tel.: +33 2 54 50 55 50
Fax: +33 2 54 42 29 19
E-Mail: direction@stauffsa.com
www.stauff.fr

Ireland

STAUFF UK Ltd.

Block B, 9 Ferguson Drive
Knockmore Hill Industrial Estate
Lisburn, County Antrim, BT28 2EX
Tel.: +44 2892 60 69 00
Fax: +44 2892 60 26 88
E-Mail: sales@stauffireland.com
www.stauff.co.uk

Italy

STAUFF Italia s.r.l

Via Borima 21 (Frazione Borima)
23867 Suello (LC)
Tel.: +39 031 65 84 94
Fax: +39 031 65 50 05
E-Mail: sales@stauff.it
www.stauff.it

Poland

STAUFF Polska Sp. z o.o.

Miszewko 43 A
80-297 Banino
Tel.: +48 58 660 11 60
Fax: +48 58 629 79 52
E-Mail: sales@stauff.pl
www.stauff.pl

Russian Federation

STAUFF LLC

Building 1
19, Leninskaya Sloboda
Moscow, 115280
Tel.: +7 495 276 16 50
Fax: +7 495 276 16 51
E-Mail: sales@stauff.ru
www.stauff.ru

United Kingdom

STAUFF UK Ltd.

500, Carlisle Street East
Off Downgate Drive
Sheffield, S4 8BS
Tel.: +44 114 251 85 18
Fax: +44 114 251 85 19
E-Mail: sales@stauff.co.uk
www.stauff.co.uk

STAUFF UK Ltd.

Badentoy Avenue
Badentoy Industrial Estate
Portlethen, Aberdeen, AB12 4YB
Tel.: +44 1224 78 61 66
Fax: +44 1224 78 61 77
E-Mail: sales@stauffscotland.co.uk
www.stauff.co.uk

STAUFF UK Ltd.

Unit 9, Southampton Trade Park
Third Avenue, Millbrook
Southampton, SO15 0AD
Tel.: +44 2380 69 87 00
Fax: +44 2380 69 87 01
E-Mail: sales@stauffsouthampton.co.uk
www.stauff.co.uk

Further branch offices in
Engels, Volzhskiy, Magnitogorsk,
Nizhny Novgorod and St. Petersburg.

North America

Canada

STAUFF Canada Ltd.

866 Milner Avenue
Scarborough
Ontario M1B 5N7
Tel.: +1 416 282 46 08
Fax: +1 416 282 30 39
E-Mail: sales@stauffcanada.com
www.stauffcanada.com

United States

STAUFF Corporation

7 Wm. Demarest Place
Waldwick, 07463-1542
New Jersey
Tel.: +1 201 444 78 00
Fax: +1 201 444 78 52
E-Mail: sales@stauffusa.com
www.stauffusa.com

Further branch office in
Canton, Michigan.

South America

Brazil

STAUFF Brasil Ltda.

Avenida Gupê 10767
Galpão 2 - Bloco A
Barueri, São Paulo, CEP 06422-120
Tel.: +55 11 47 72 72 00
Fax: +55 11 47 72 72 10
E-Mail: stauff@stauffbrasil.com
www.stauffbrasil.com



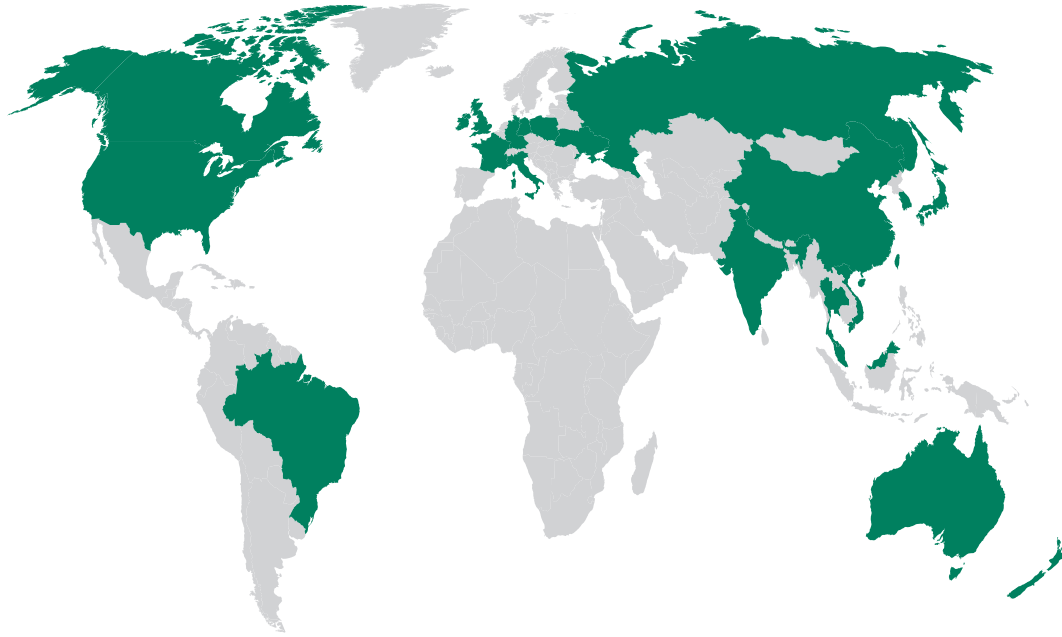

Asia

China

STAUFF CHINA

Building 1, No. 128, Die Qiao Road
Jushuo Industrial Zone, Kang Qiao
Shanghai, 201319
Tel.: +86 21 68 18 70 00
Fax: +86 21 68 18 71 36
E-Mail: info@stauff.com.cn
www.stauff.com.cn

Further branch offices in Beijing,
Changsha, Chengdu, Changchun,
Chongqing, Jinan, Harbin, Guangzhou,
Shenyang, Wuhan, Xian and Xuzhou.

India

STAUFF India Pvt. Ltd.

Gat no. 26/1 & 27, Sanghar Warehousing
Pune - Nagar Road
Lonikand - 412216
Tel.: +91 20 6731 4900
Fax: +91 20 6731 4905
E-Mail: sales@stauffindia.com
www.stauffindia.com

Korea

STAUFF Korea Ltd.

105, Hwajeonsandan 5-ro
Gangseo-gu
Busan, 46739
Tel.: +82 51 266 6666
Fax: +82 51 266 8866
E-Mail: info@stauff.co.kr
www.stauff.co.kr

Malaysia

STAUFF South East Asia Sdn Bhd

No. 8, Jalan SS13/6A
Subang Jaya Industrial Estate
47500 Subang Jaya
Tel.: +60 3 5637 78 88
Fax: +60 3 5636 78 90
E-Mail: sales@stauff.com.my
www.stauff.com.my

Thailand

STAUFF (Thailand) Co., Ltd.

10 Soi On-Nut 74/4
Pravet District
Bangkok 10250
Tel.: +66 2 721 73 23 / 24
Fax: +66 2 721 73 35
E-Mail: sales@stauff.co.th
www.stauff.co.th

Vietnam

STAUFF Vietnam Ltd.

2nd Floor, CT-IN Building
#435 Hoang Van Thu Street
Tan Binh District, Ho Chi Minh City
Tel.: +84 8 3948 10 41 / 42
Fax: +84 8 3948 10 44
E-Mail: sales@stauff.com.vn
www.stauff.com.vn

Oceania

Australia

STAUFF Corporation Pty Ltd

24-26 Doyle Avenue
Unanderra NSW 2526
Tel.: +61 2 4271 9000
Fax: +61 2 4271 8432
E-Mail: sales@stauff.com.au
www.stauff.com.au

Further branch offices in
Adelaide, Brisbane, Melbourne
and Sydney.

New Zealand

STAUFF Corporation (NZ) Ltd.

Unit D, 103 Harris Road
East Tamaki, Auckland 2013
Tel.: +64 9 271 48 12
Fax: +64 9 271 48 32
E-Mail: sales@stauff.co.nz
www.stauff.co.nz



Introduction

SAE Split Flange Halves / Flange Clamps

SAE Flange / Counterflange Adaptors

SAE Single-Part Flanges / Counterflanges

Accessories for SAE Flanges

SAE Flange Blocks

Gear Pump Flanges

Assembly Instructions

Appendix



Catalogue 3 STAUFF Flanges

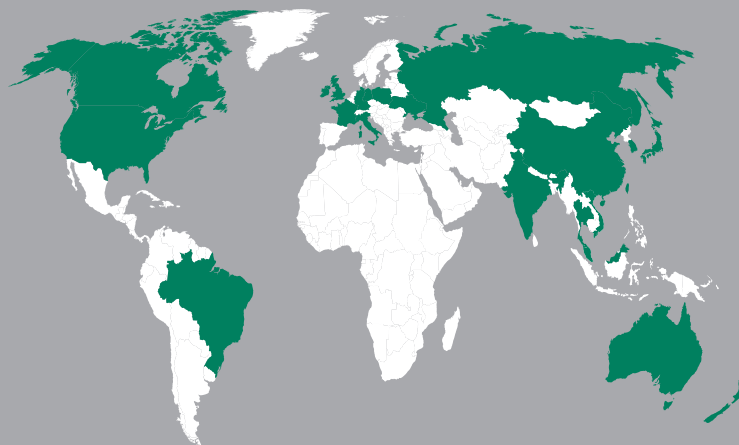

Germany

Walter Stauffenberg GmbH & Co. KG
Im Ehrenfeld 4
58791 Werdohl
Tel.: +49 2392 91 60
Fax: +49 2392 91 61 60
E-Mail: sales@stauff.com

STAUFF products and services are globally available through wholly-owned subsidiaries and a tight network of authorised distributors and representatives in all major industrial regions of the world.

You can find detailed contact information on the last two pages of this product catalogue or at

www.stauff.com